



# 12,000 BTU/H FLOOR MOUNTED HEAT PUMP SYSTEM

SUBMITTAL COVER SHEET

PROJECT NAME \_\_\_\_\_

LOCATION \_\_\_\_\_

ARCHITECT \_\_\_\_\_

ENGINEER \_\_\_\_\_

CONTRACTOR \_\_\_\_\_

REFERENCE \_\_\_\_\_

SUBMITTED BY \_\_\_\_\_ DATE \_\_\_\_\_

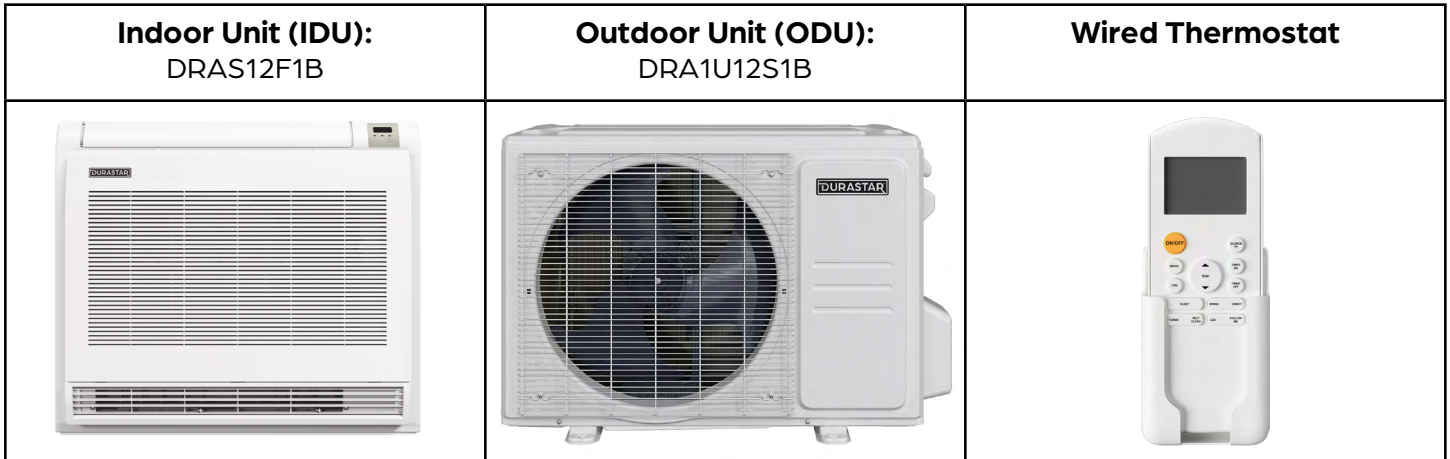

## PRODUCT FEATURES

- Wireless Remote Control with "Follow Me" Technology
- Variable Speed Inverter Compressor
- Auto Restart
- Sleep Mode
- Turbo Mode
- 24-Hour Timer Feature
- Quiet operation
- 46°F Freeze Protection
- Low ambient heating down to -13 °F
- Low ambient cooling down to 5 °F
- Included base pan heater
- Refrigerant leak detection
- Anti-corrosive fin coating

CAPACITIES		
Cooling Capacity (BTU/hr)	Rated at 95 °F	12000
	Minimum	2850
	Maximum	13000
Heating Capacity (BTU/hr)	Rated at 47 °F	12000
	Maximum at 5 °F	8000
	Minimum	2250
	Maximum	14800

SYSTEM DATA	
Refrigerant Type	R-410A
Refrigerant Charge (oz.)	38.1
Design Pressure (PSIG)	550/340
Indoor/ Outdoor Coil Coating	Golden Fin Coating

EFFICIENCY DATA	
SEER2	22.7
EER2	13.0
HSPF2	10.2
SEER	21.5
EER	13.0
HSPF	10.0
COP at 47 °F	3.52
COP at 5 °F	2.26





# 12,000 BTU/H FLOOR MOUNTED HEAT PUMP SYSTEM

## SPECIFICATIONS

LINE SET REQUIREMENTS	
Connection Type	Flare
Liquid	Ø1/4" (Ø6.35mm)
Gas	Ø1/2" (Ø12.7mm)
Pre-Charge Length	25'
Minimum Length	10'
Maximum Length	82'
Maximum Height Differential	33'
Additional Refrigerant (oz./ft)	0.16

OUTDOOR UNIT		
Unit Dimensions	Width	30 1/8"
	Depth	11 15/16"
	Height	21 7/8"
Carton Dimensions	Width	34 15/16"
	Depth	13 1/4"
	Height	24"
Net Weight	63.7 lbs.	
Gross Weight	69.0 lbs.	
Cooling Operating Temperature	5 °F - 122 °F	
Heating Operating Temperature	-13 °F - 75 °F	
Voltage/Phase/Frequency	208-230V, 1 Phase, 60 Hz	
Voltage Range	187-253V	
Recommended Breaker (Amps)	15	
Minimum Circuit Ampacity (Amps)	13	
Communication Wire Size	14*4 AWG Stranded	
Rated Current - Cooling (Amps) <sup>1</sup>	4.22	
Rated Current - Heating (Amps) <sup>2</sup>	4.58	
Sound Pressure (dB(A))	53.5	

COMPRESSOR	
Type	DC Rotary Inverter
Oil Type	Ester Oil VG74
Oil Charge (oz.)	10.5 (310 ml)

INDOOR UNIT		
Unit Dimensions	Width	27 9/16"
	Depth	8 1/4"
	Height	23 5/8"
Carton Dimensions	Width	30 11/16"
	Depth	11 13/16"
	Height	27"
Net Weight	32.6 lbs.	
Gross Weight	41.0 lbs.	
Indoor Unit Air Flow (CFM)	Low	248
	Medium	318
	High	365
Drain Port O.D. / Drain Hose I.D.	Ø5/8" (Ø16mm)	
Recommended Breaker (Amps)	15	
Minimum Circuit Ampacity (Amps)	3	
Sound Pressure (dB(A))	Low	33
	Medium	39
	High	43

<sup>1</sup> Measured at 95 °F.

<sup>2</sup> Measured at 47 °F.

Specifications are subject to change without notice.

© 2022 Ferguson Enterprises LLC

www.durastar.com



# 12,000 BTU/H FLOOR MOUNTED HEAT PUMP SYSTEM

IDU DIMENSIONS - DRAS12F1A

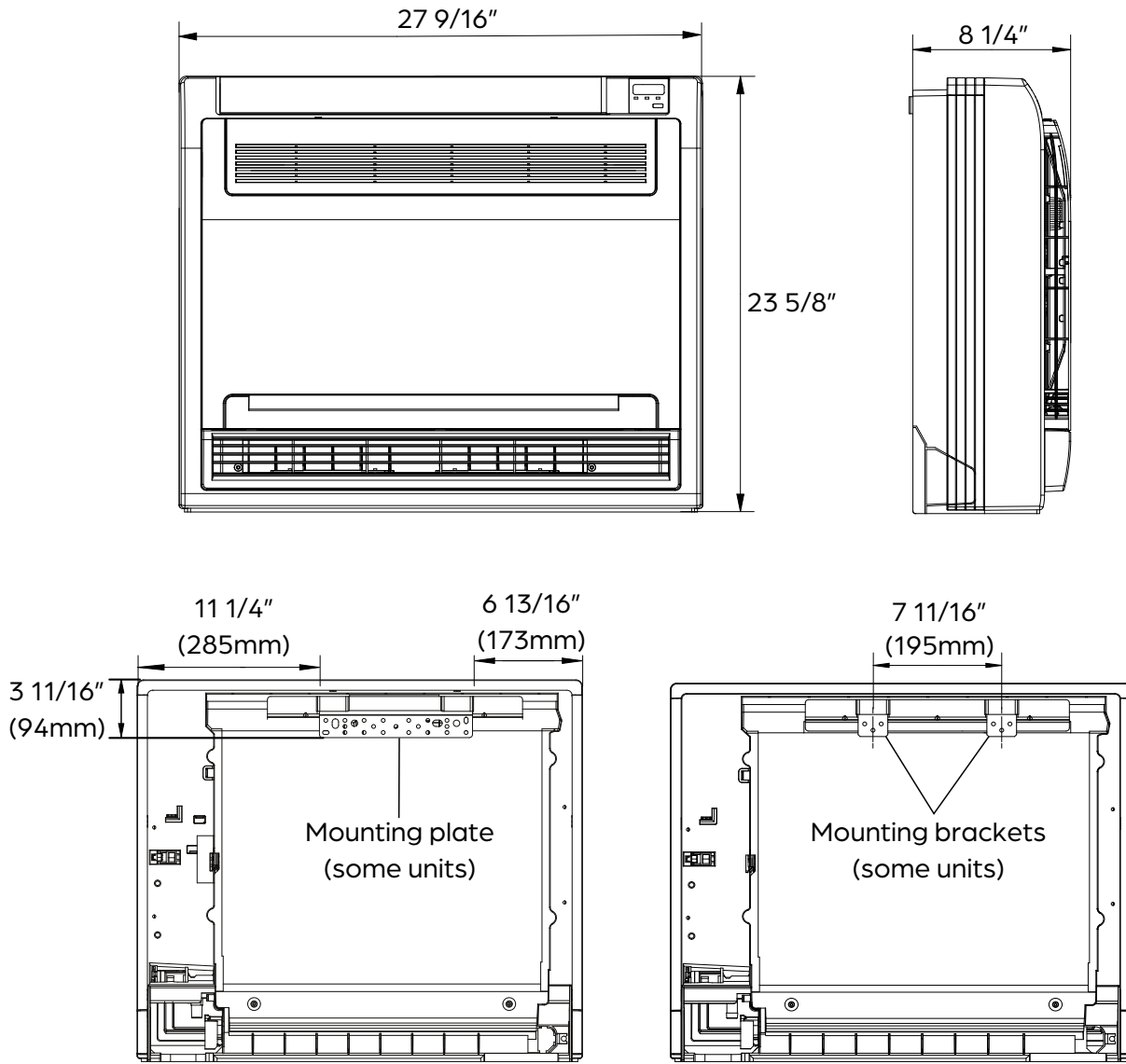



# 12,000 BTU/H FLOOR MOUNTED HEAT PUMP SYSTEM

ODU DIMENSIONS - DRA1U12S1B

## Clearances

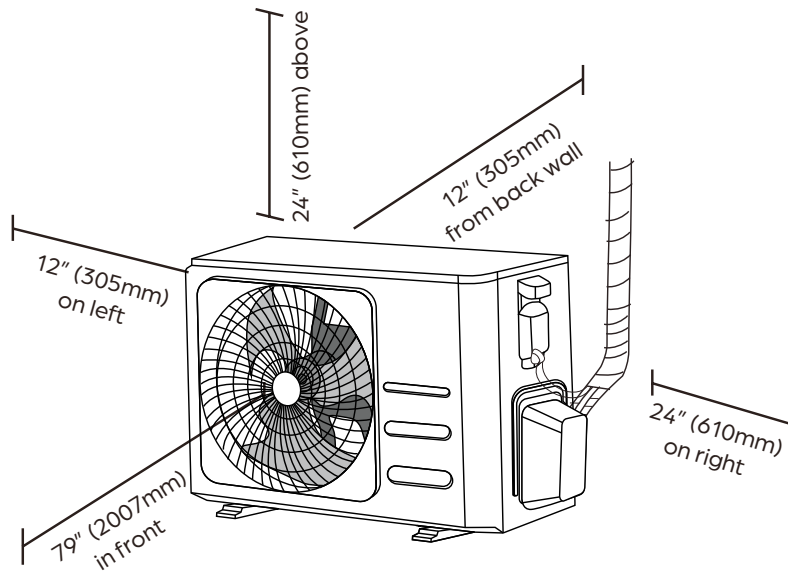

## Dimensions

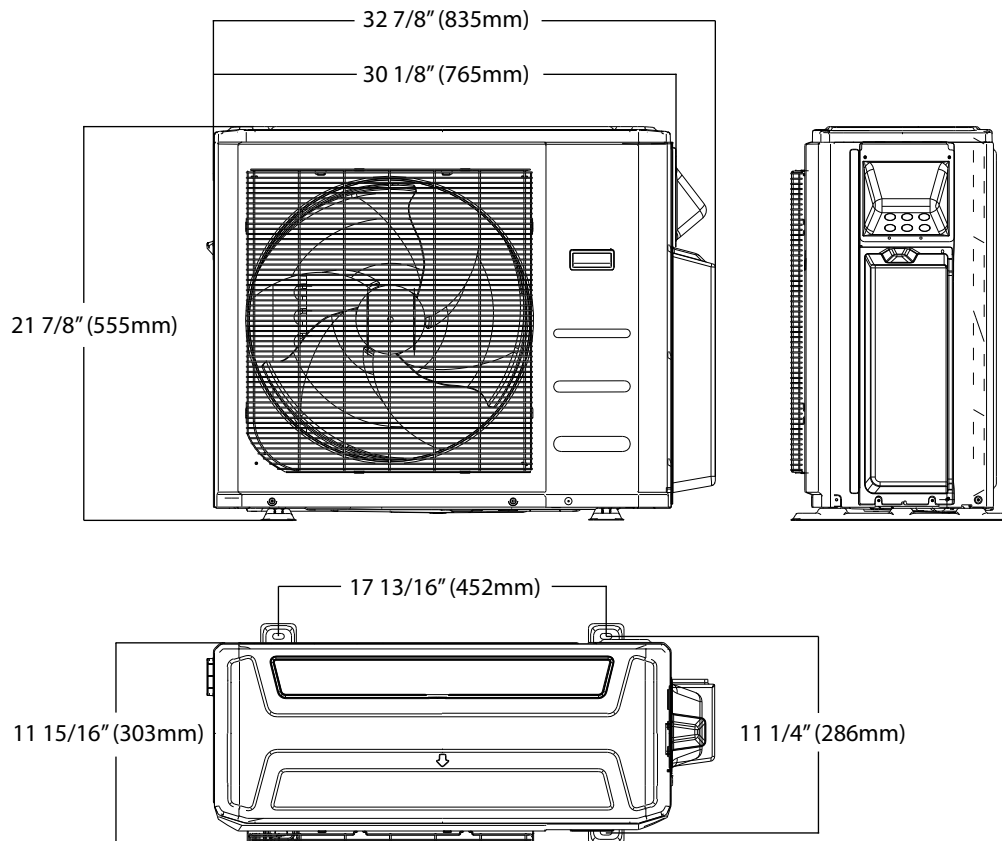

### NOTE

Illustrations in this document are for explanatory purposes. The actual shape of your mini-split equipment may vary slightly.