

# 200WW Ductile Iron Gate Valve • Spec Sheet

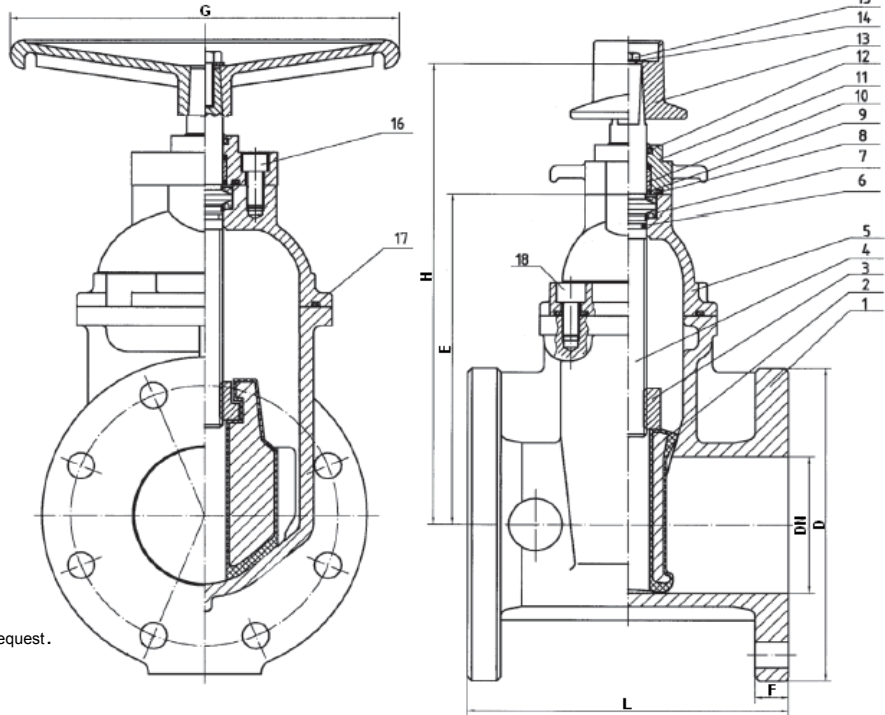

\* Valve comes standard with wheel handle . 2" Op Nut available upon request .

## MATERIAL SPECIFICATIONS

No	Part	Material
1	Valve Body	Ductile Iron ASTM A536
2	Resilient Wedge	Ductile Iron ASTM A536/ EPDM ASTM D2000
3	Stem Nut	Bronze ASTM B584
4	Stem	Stainless Steel AISI 410
5	Bonnet	Ductile Iron ASTM A536
6	Stem Primary O-Ring	EPDM ASTM D2000
7	Stem Gasket	NYLON 1010
8	Gland Seal O-Ring	EPDM ASTM D2000
9	Stem Secondary O-Ring	EPDM ASTM D2000
10	Stem Seal Bushing	NYLON 1010
11	Packing Gland	Ductile Iron ASTM A536
12	Wiper Ring	EPDM ASTM D2000
13	Operating Nut	Cast Iron ASTM A126-B
14	Washer	Stainless Steel AISI 410
15	Bolts	Stainless Steel AISI SS304
16	Gland Bolts	Stainless Steel AISI SS304
17	Bonnet Gasket	EPDM ASTM D2000
18	Bonnet Bolt	Stainless Steel AISI SS304

## FEATURES & BENEFITS

- Gate Valve - Flanged Ends
- 250 CWP - Max Temp. 230° F.
- AWWA C550 Fusion Bonded Epoxy
- EPDM Resilient Wedge
- Non Rising Stem
- Manufactured to AWWA C509-15
- Flanged End Conforms with ANSI B16.1

## APPLICATIONS

Potable Water, Irrigation, Turf, Sewage Disposal, Golf Course, Water Distribution Service and Feed Lines.

## DIMENSIONS

Size (DN)	L	F	D	E	H	G
2"	7.00	0.63	6.00	6.30	10.80	7.88
3"	8.00	0.75	7.50	8.35	12.85	10.24
4"	9.00	0.95	9.00	9.69	14.18	10.24
6"	10.50	1.00	11.00	13.00	17.61	14.78
8"	11.50	1.13	13.50	16.15	20.92	14.78
10"	13.00	1.19	16.00	13.00	17.61	15.76
12"	14.00	1.26	19.00	16.15	20.92	19.70



**CALIFORNIA** 5595 Fresca Dr., La Palma CA 90623  
**TEXAS** 1150 Silber Rd., Houston TX 77055  
**ILLINOIS** 278 Windy Point Dr., Glendale Heights, IL 60139  
**GEORGIA** 113 Industrial Blvd., Americus, Georgia 31709  
**NEW YORK** PO Box 27, Rt.22, Brewster NY 10509  
 WEB: [www.matco-norca.com](http://www.matco-norca.com)

• Phone: 866-532-8306 • Fax: 866-532-8307  
 • Phone: 800-935-5456 • Fax: 713-680-2999  
 • Phone: 844-412-5068 • Fax: 800-640-2252  
 • Phone: 800-433-7526 • Fax: 800-533-5134  
 • Phone: 800-431-2082 • Fax: 845-278-9056  
 EMAIL: [mail@matco-norca.com](mailto:mail@matco-norca.com)