

DB Series Duplex Basket Strainers

1/2" TO 4" PVC, CPVC AND EASTAR®

KEY FEATURES

- Available in PVC, CPVC and Eastar®
- Ergonomic Hand-Removable Cover
- Uninterrupted Flow
- No System Shutdown for Basket Cleaning
- In-Line or Loop Piping
- Integral Flat Mounting Bases
- External Cover Threads
- Hand Removable Vents on Covers
- Hand Removable Drains on Bodies
- Liquid Displacing Covers

OPTIONS

- Stainless Steel, Monel®, Hastelloy® and Titanium Strainer Baskets
- Pressure Differential Gauge and Switch
- Pneumatic or Electric Valve Automation
- Baskets Available with Perforated or Mesh Liners

MATERIALS

- PVC Cell Class 12454 per ASTM D1784
- CPVC Cell Class 23447 per ASTM D1784
- Eastar®
- FPM and EPDM O-Ring Seals



TECHNICAL INFORMATION

BASKET OPTIONS

PERFORATION SIZES	MESH SIZES	BASKET MATERIAL
1/32"	20	SSTL, Hastelloy, Monel and Titanium
1/16"	40	
1/8"	60	
5/32"	80	
3/16"	100	
1/4"	200	
3/8"	325	
<hr/>		
1/32"	N/A	PVC, CPVC and PP
1/16"		
1/8"		
3/16"		

SELECTION CHART

SIZE**	MATERIAL	END CONNECTION	SEALS	PRESSURE RATING
1/2" – 4" (DN15 – DN100)	PVC or CPVC	Socket, Threaded or Flanged	FPM or EPDM	150 PSI @ 70°F 10 Bar @ 21°C Non-Shock
	Eastar*			100 PSI @ 70°F 7 Bar @ 21°C Non-Shock

* End connections and assembly nuts are PVC.
 ** PVC and CPVC socket ends available to ISO 727-1 and threaded ends to BS21.
 *** Flanged ends available in DIN / EN PN10.

DB Series Duplex Basket Strainers

1/2" TO 4" PVC, CPVC AND EASTAR®

TECHNICAL INFORMATION, CONTINUED

PARTS LIST

1. Single Stem Lateral
2. Double Stem Lateral
3. Inlet Flange
4. Cover
5. Strainer Body
6. Spool
7. Drain Plug and O-Ring
8. Vent Plug and O-Ring

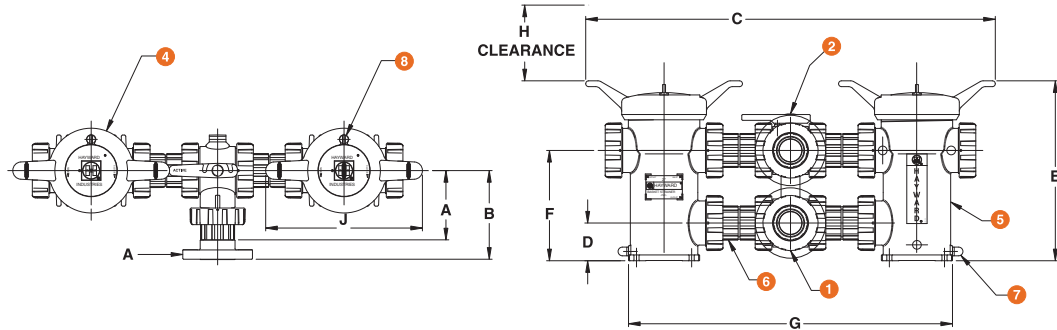

DIMENSIONS

SIZE in / DN	A in / mm	B in / mm	C in / mm	D in / mm	E in / mm	F in / mm	G in / mm	H in / mm	J in / mm	WEIGHT lbs / kg	
										SOC / THD	FLANGED
1/2 / 15	4.14 / 105	5.21 / 132	27.20 / 691	2.25 / 57	11.70 / 297	6.75 / 171	20.50 / 521	5.00 / 127	11.00 / 279	20.00 / 9.07	21.00 / 9.53
3/4 / 20	4.14 / 105	5.33 / 135	27.20 / 691	2.25 / 57	11.70 / 297	6.75 / 171	20.50 / 521	5.00 / 127	11.00 / 279	20.00 / 9.07	21.00 / 9.53
1 / 25	4.14 / 105	5.64 / 143	27.20 / 691	2.25 / 57	11.70 / 297	6.75 / 171	20.50 / 521	5.00 / 127	11.00 / 279	20.00 / 9.07	21.00 / 9.53
1-1/4 / 32	6.00 / 152	7.44 / 189	35.30 / 897	3.25 / 83	15.50 / 394	9.50 / 241	28.00 / 711	10.80 / 274	13.50 / 343	39.50 / 17.92	42.00 / 19.05
1-1/2 / 40	6.00 / 152	7.60 / 193	35.30 / 897	3.25 / 83	15.50 / 394	9.50 / 241	28.00 / 711	10.80 / 274	13.50 / 343	39.50 / 17.92	42.00 / 19.05
2 / 50	6.00 / 152	7.77 / 197	35.30 / 897	3.25 / 83	15.50 / 394	9.50 / 241	28.00 / 711	10.80 / 274	13.50 / 343	39.50 / 17.92	42.00 / 19.05
2-1/2 / 65	7.60 / 193	9.85 / 250	44.40 / 1128	4.83 / 123	22.30 / 566	14.83 / 377	35.60 / 904	14.80 / 376	16.00 / 406	83.00 / 37.65	88.00 / 39.92
3 / 80	7.60 / 193	9.85 / 250	44.40 / 1128	4.83 / 123	22.30 / 566	14.83 / 377	35.60 / 904	14.80 / 376	16.00 / 406	83.00 / 37.65	88.50 / 40.14
4 / 100	9.33 / 237	11.76 / 299	47.50 / 1207	4.83 / 123	22.30 / 566	14.83 / 377	38.70 / 983	14.80 / 376	16.00 / 406	100.00 / 45.36	105.00 / 47.63

Dimensions are subject to change without notice – consult factory for installation information

PRESSURE DROP CALCULATIONS

BASKET PERFORATION CORRECTION FACTORS

For 1/2" to 4" Strainers

Plastic		Stainless Steel	
1/32"	1.05	1/32"	.82
1/16"	1.00	1/16"	.74
1/8"	.58	1/8"	.58
3/16"	.46	5/32"	.37
		3/16"	.46
		1/4"	.58
		3/8"	.45
		20 Mesh	.79
		40 Mesh	1.01
		60 Mesh	1.20
		80 Mesh	1.16
		100 Mesh	1.20
		200 Mesh	1.09
		325 Mesh	1.22

PRESSURE LOSS CALCULATION FORMULA

The pressure drop across the strainer, for water or fluids with a similar viscosity, can be calculated using the formula at the right:

$$\Delta P = \left[\frac{Q}{C_v} \right]^2$$

ΔP = Pressure Drop

Q = Flow in GPM

C_v = Flow Coefficient

Cv VALUES

SIZE in / DN	Cv VALUES	SIZE in / DN	Cv VALUES
1/2 / 15	12.5	1-1/2 / 40	45
3/4 / 20	13	2 / 50	48
1 / 25	14	3 / 80	200
1-1/4 / 32	40	4 / 100	280

The Cv Values were determined using a 1/16" perforated plastic basket in 1/2" through 4" strainers.

To calculate pressure drop through vessels using other than 1/16" perforated baskets, first calculate the pressure drop using the listed Cv, and then multiply the result by the correction factor in the Correction Factors chart to the left.

OPERATING TEMPERATURE/PRESSURE

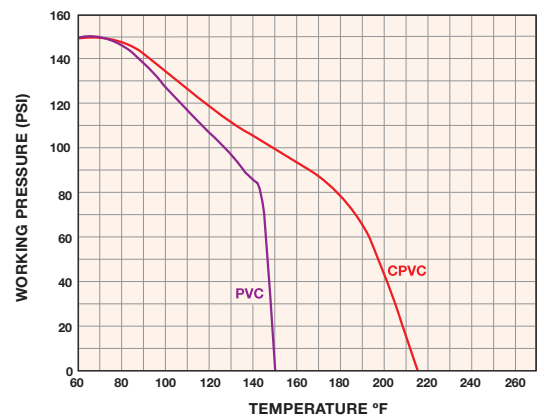

 Hayward is a registered trademark of Hayward Industries, Inc.
© 2021 Hayward Industries, Inc.

– Eastar is a registered trademark of Eastman.
– Hastelloy is a registered trademark of Haynes International Inc.
– Monel is a registered trademark of Special Metals Corporation.

USA: 1.888.429.4635 • Fax: 1.888.778.8410 • One Hayward Industrial Drive • Clemmons, NC 27012 • Email: hfcsales@hayward.com

Canada: 1.888.238.7665 • Fax: 1.905.829.3636 • 2880 Plymouth Drive • Oakville, ON L6H 5R4 • Email: hflowcanada@hayward.com

Visit us at: haywardflowcontrol.com