

1. Attach carrier legs to concrete floor with minimum 1/2" dia. anchor bolts (by others).
2. Determine pitch and rough-in requirements (see chart). For carriers set in a low position, break scored steps from lower portion of faceplate with a heavy hammer.
3. Attach faceplate assembly to carrier fitting with 1/2" bolts and washers (supplied). Place oval fitting gasket between faceplate and fitting prior to bolting.
4. Adjust faceplate assembly to accommodate bowl height by loosening side leg bolts. Adjust fitting to accommodate pitch requirement by loosening bolts.
5. Adjust ABS nipple and studs. ABS nipple should extend 5/16" beyond finished wall. Studs should extend 2-1/4" beyond finished wall. *Wall constructor must leave approx. 2" opening around nipple to access compression bolts. Use 30 – 50 in. lbs. of torque to tighten compression bolts.*
6. Install neoprene bowl gasket on horn in back of bowl, knock out nipple test cap, and set bowl.
7. Install chrome cap nuts and plastic washer over studs. Tighten cap nuts fully to properly load the carrier.

** CONSULT FACTORY PRIOR TO INSTALLATION WITH BLOW-OUT FIXTURES

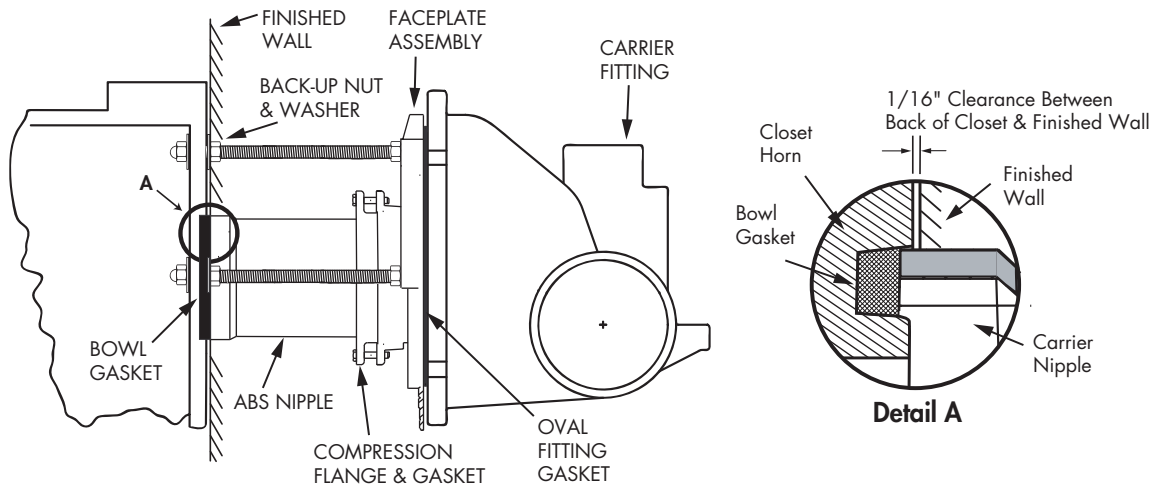

BATTERY PITCH & ROUGH-IN REQUIREMENTS

C/L Bowl Outlet From Floor	Min. C/L Horiz. Waste From Floor	Max. C/L Horiz. Waste From Floor
4-1/2"	3"	4-1/2"
5"	3"	5"
5-1/2"	3"	5-1/2"
6"	3"	6"
6-1/2"	3-1/4"	6-1/2"
7"	3-5/8"	7"
7-1/2"	4-1/8"	7-1/2"
8"	4-5/8"	8"
8-1/2"	5"	8-1/2"
9"	5-3/8"	9"
9-3/8"	5-3/4"	9-3/8"

WATTS Drainage reserves the right to modify or change product design or construction without prior notice and without incurring any obligation to make similar changes and modifications to products previously or subsequently sold. See your WATTS Drainage representative for any clarification. Dimensions are subject to manufacturing tolerances.