



Myers®

Pentair Water

JET PUMPS

HR Series Convertible

HR SERIES

Myers® HR Series jet pumps provide reliable service for many residential homes and farms, as well as commercial and industrial applications.

APPLICATIONS

Supply water systems and sprinkling systems for homes, farms and industry

SPECIFICATIONS

- Cast iron pump case
- Dual compartment, 115/230 Volt double-ball bearing motor with voltage selector switch
- Priming screen
- Diffuser with stainless steel wear ring
- Square D pressure switch

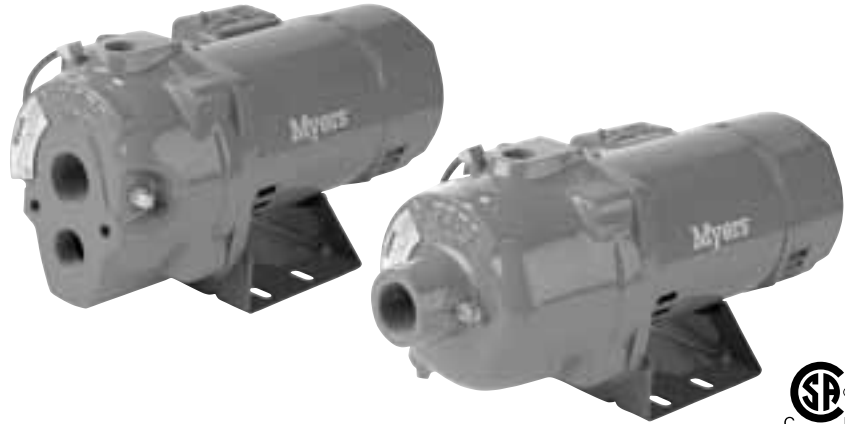

FEATURES

Quality Construction

Durable machined heavy-duty construction pump body provides long product life

Impellers

Precision molded impellers and diffuser provide smooth, balanced performance and efficiency

Pressure Switch

High quality proven pressure switch with adjustable on/off pressure settings. 20 PSI differential.

Motor

Heavy-duty motor with double ball bearing design and voltage selection device

Shaft Seal

Mechanical shaft seal with ceramic face and stainless steel construction for long seal life

ORDERING INFORMATION – Shallow Well

Catalog Number	HP	Discharge Pressure in Lbs.	Capacity in U.S. Gallons per Minute Suction Lift in Feet			Shut-Off PSI
			5	15	20	
HR50S	1/2	20	11.5	9	6	70
		30	11.5	9	6	
		40	10.5	7.5	5	
		50	5.5	3.5	2	

ORDERING INFORMATION – Deep Well

Catalog Number	HP	Pressure Switch Setting	Average Regulator Setting	Jet Package Cat. Number			Capacity in U.S. Gallons per Minute Distance to Low Water Level in Feet					
				Cast Iron	Bronze	Packer for 2" Well	30	40	50	60	70	80
HR50D	1/2	20/40	22	DW50-1	DW50	P50	10	8	7	5.5	4.5	3.5
		30/50	22	DW50-1	DW50	P50	9.5	7.5	6.5	5	4	3.5

Myers® is a registered trademark of Pentair Water.



Myers[®]

Pentair Water

JET PUMPS

HR Series Convertible

OUTLINE DIMENSIONS

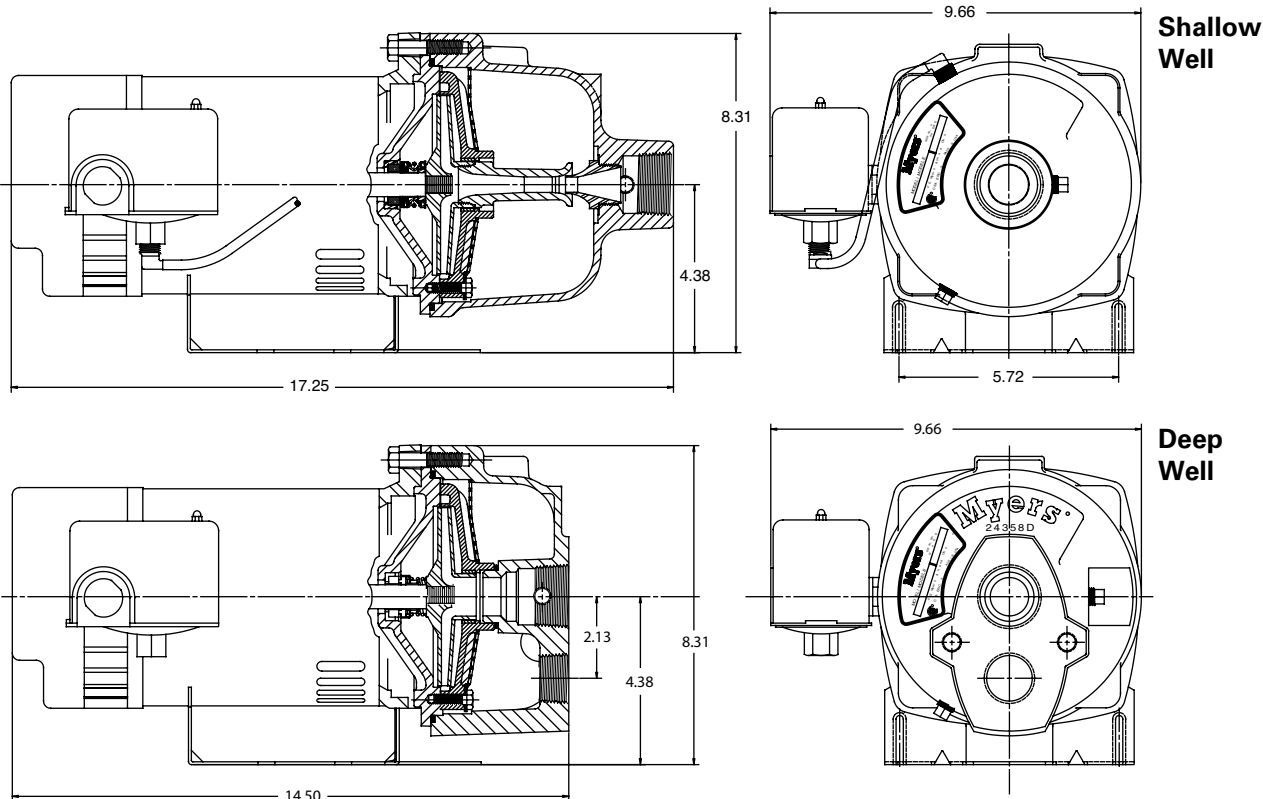

Dimensions (in inches) are for estimating purposes only.

PUMP PERFORMANCE

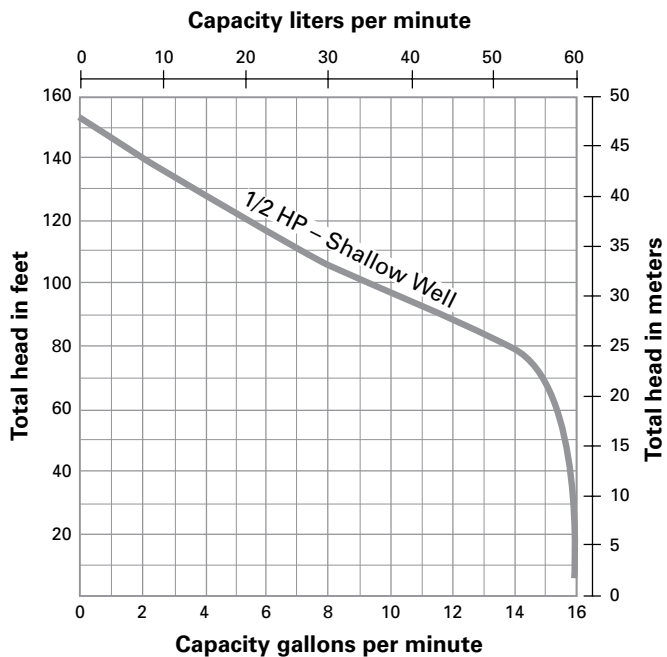

Repair Parts Kit for HR Series	
Kit	Includes
PK50	Shaft seal, impeller, diffuser, gasket, O-ring, venturi, and nozzle