



# Fantech

Your Ventilation Solutions Company

## SHR & VHR Series Heat Recovery Ventilator

### Installation Manual

**IMPORTANT - PLEASE READ THIS MANUAL  
BEFORE INSTALLING UNIT**



**CAUTION** - Before installation, careful consideration must be given to how this system will operate if connected to any other piece of mechanical equipment, i.e. a forced air furnace or air handler, operating at a higher static. After installation, the compatibility of the two pieces of equipment must be confirmed by measuring the airflow's of the Heat Recovery or Energy Recovery Ventilators by using the balancing procedure found in this manual.

It is always important to assess how the operation of any HRV/ERV may interact with vented combustion equipment (i.e. Gas Furnaces, Oil Furnaces, Wood Stoves, etc.).

**NEVER** - install a ventilator in a situation where its normal operation, lack of operation or partial failure may result in the backdrafting or improper functioning of vented combustion equipment!!!



Your ventilation system should be installed in conformance with the appropriate provincial or state requirements or in the absence of such requirements with the current edition of the National Building Code, and / or ASHRAE's " Good Engineering Practices".

## SHR & VHR Models

SHR 1504 • SHR 1505 R(D) • SHR 2004 • SHR 2005 R(D) • SHR 3005 R • SHR 3205RD  
VHR 1404 • VHR 1405 R • VHR 2004 • VHR 2005 R

# TABLE OF CONTENTS

TECHNICAL DATA	
SHR(D) Series	3
SHR Series	4
SHR 3005R	5
VHR Series	7
MODES OF OPERATION	
INSTALLATION	9
Mounting the Unit	9
Location & Ducting	10
Examples	12
Air Flow Balancing	14
ELECTRICAL CONNECTIONS	15

Example for maximum airflow normally required.

HRVs are typically sized to ventilate the whole house at a minimum of 0.35 air changes per hour. To calculate, simply take the square footage of the house (including basement) and multiply by the height of the ceiling to get cubic volume. Then, divide by 60 and multiply by 0.35.

Example:	SQFT of House	1100
	Basement	1100
	Total SQFT	2200
	Height of ceiling	x 8
	Cubic volume	17600
		/ 60
Maximum airflow required (CFM)		293
		x 0.35
		103

\* Always consult your local code for sizing requirements in your area.

## Alternate Method

**\*\*\*Illustrations & images in this manual may not be exactly like unit purchase, these illustrations & images are for examples only.\*\*\***

Room classification	Number of rooms	CFM (L/s)	CFM Required
Master bedroom		x 20 cfm (10 l/s)	=
Basement	yes or no	if yes add 20 cfm / 10 l/s if no = 0	=
Bedrooms		x 10 cfm (5 l/s)	=
Living room		x 10 cfm (5 l/s)	=
Others		x 10 cfm (5 l/s)	=
Kitchen		x 10 cfm (5 l/s)	=
Bathroom		x 10 cfm (5 l/s)	=
Laundry room		x 10 cfm (5 l/s)	=
Utility room		x 10 cfm (5 l/s)	=

1 cfm = 0.47189 l/s
1 l/s = 3.6 m <sup>3</sup> /hr

**Total Ventilation Requirements (add last column ) =**

# SHR 1505R(D) & 2005R Series HRV

## Dimensions

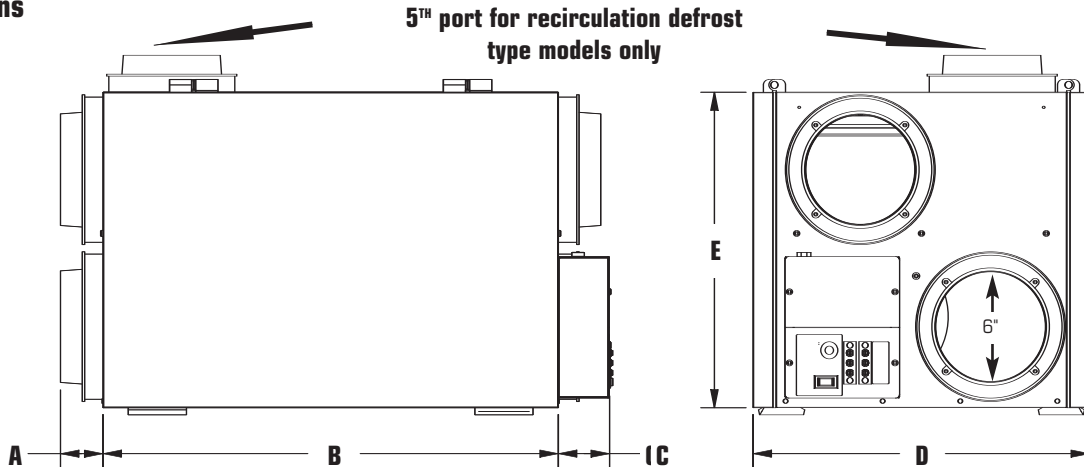

Model	A	B	C	D	E
SHR 1505R(D)	2 ¼" (56mm)	23 ½" (596mm)	2 ⅝" (67mm)	17 ⅝" (441mm)	17 ⅝" (441mm)
SHR 2005R(D)	2 ¼" (56mm)	27 ⅞" (707mm)	2 ⅝" (67mm)	17 ⅝" (441mm)	20 ½" (520mm)

## Fan Performance

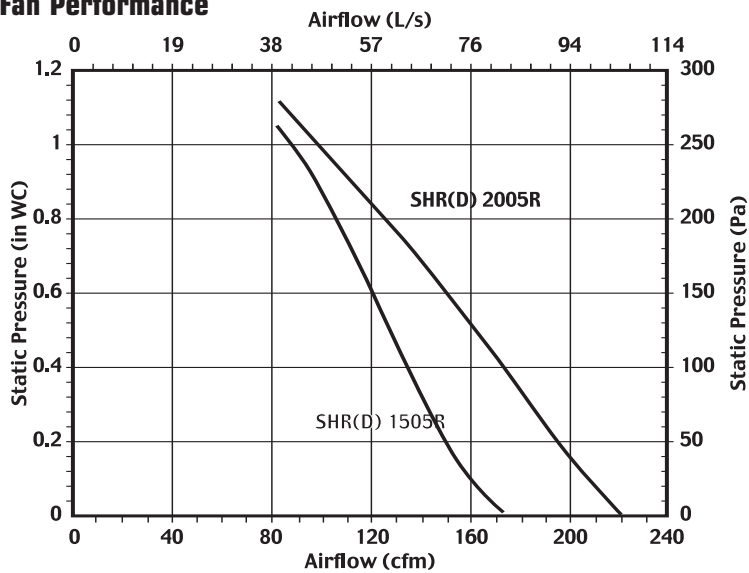

## Performance Data

Model	Apparent Sensible Effectiveness at 32°F (0°C)	Apparent Sensible Effectiveness at -13°F (-25°C)
SHR 1505R(D)	72 %	69 %
SHR 2005R(D)	71 %	76 %

AIRFLOW CAP. cfm (L/s) @ 0.4 on High Speed

**Power**

- Volts: 120 VAC
- Amperage:
  - SHR 1505R(D): 1.5 Amps Total
  - SHR 2005R(D): 1.9 Amps Total
- Phase: Single Phase



## Airflow

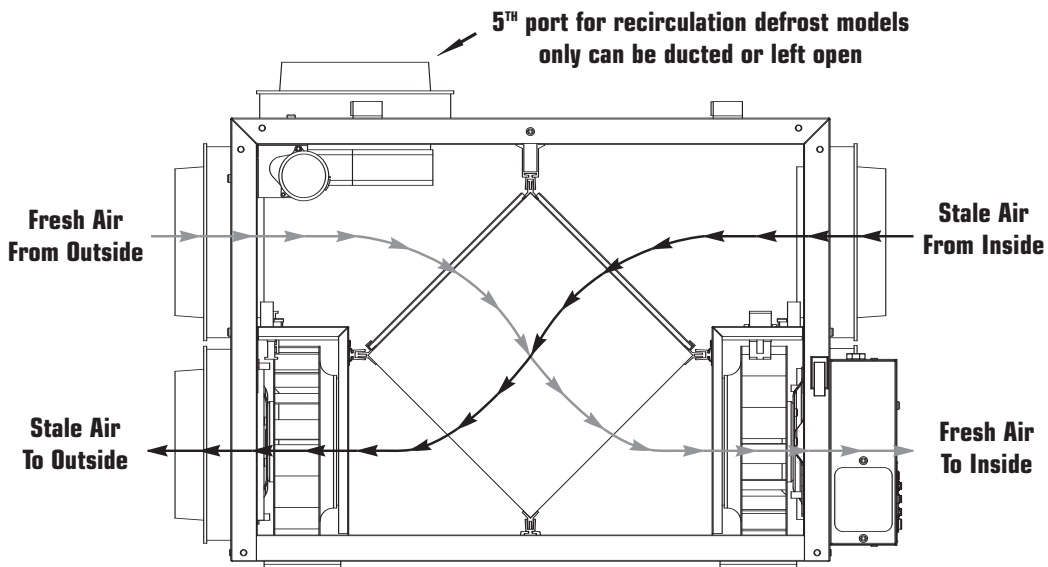

# SHR 1504 & 2004 Series HRV

## Dimensions

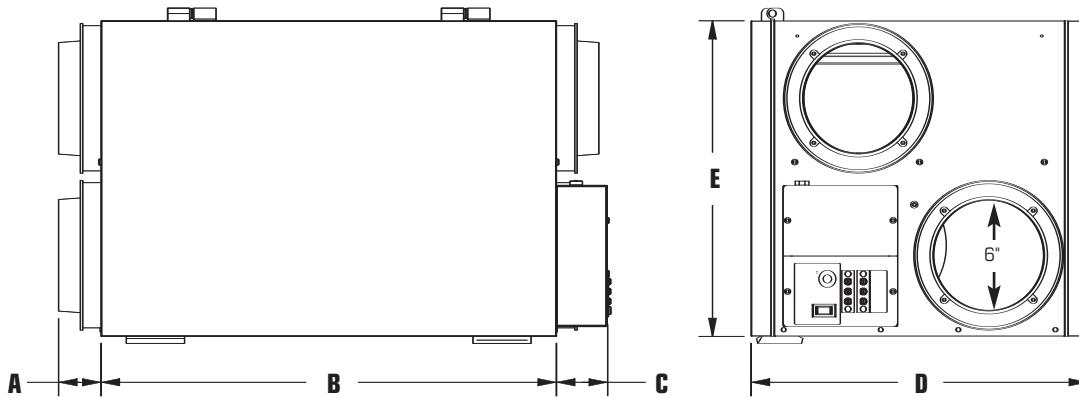

Model	A	B	C	D	E
SHR 1504	2 1/4" (56mm)	23 1/2" (596mm)	2 5/8" (67mm)	17 3/8" (441mm)	16 1/8" (413mm)
SHR 2004	2 1/4" (56mm)	27 7/8" (707mm)	2 5/8" (67mm)	17 3/8" (441mm)	20 1/2" (520mm)

## Fan Performance

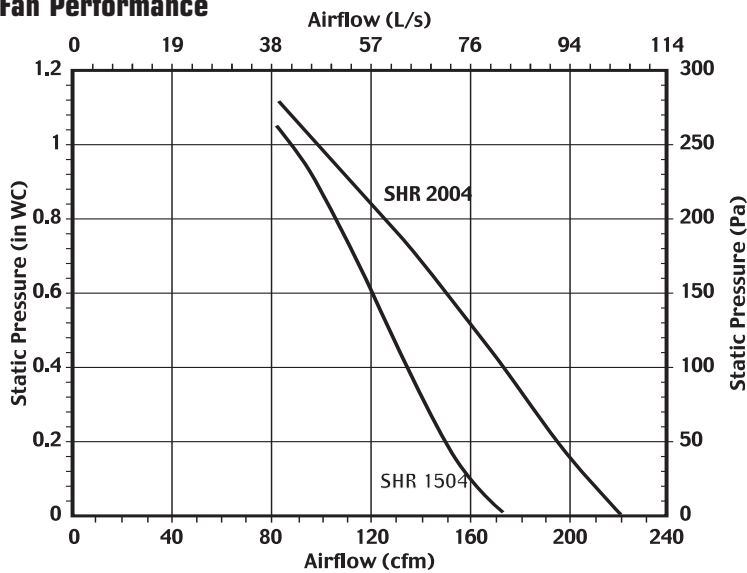

## Performance Data

Model	Apparent Sensible Effectiveness at 32°F (0°C)	Apparent Sensible Effectiveness at -13°F (-25°C)
SHR 1504	72 %	69 %
SHR 2004	71 %	76 %

AIRFLOW CAP. cfm (L/s) @ 0.4 on High Speed

**Power**

- Volts: 120 VAC
- Amperage:
  - SHR 1504: 1.5 Amps Total
  - SHR 2004: 1.9 Amps Total
- Phase: Single Phase



## Airflow

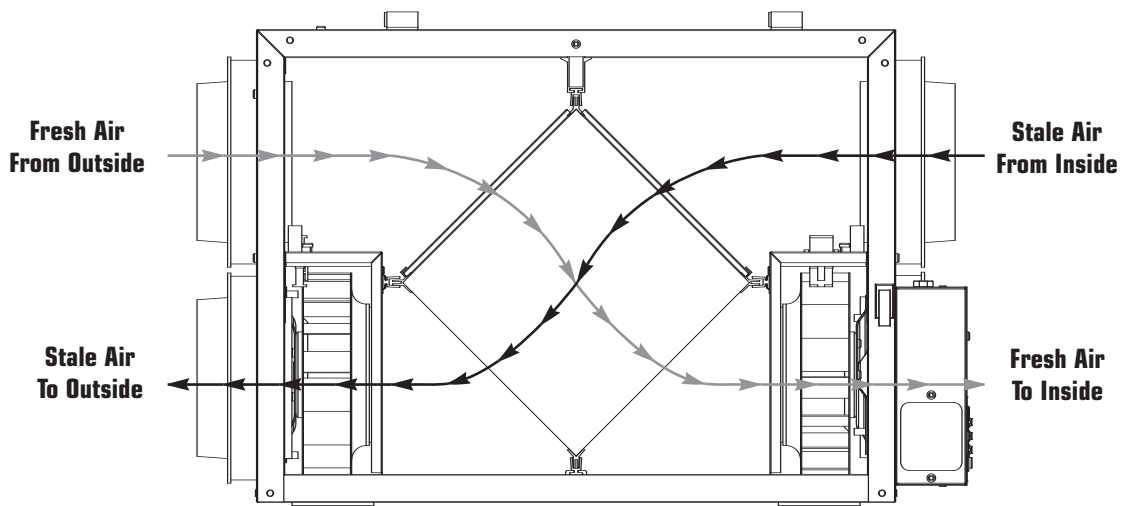

# SHR 3005R Series HRV

## Dimensions

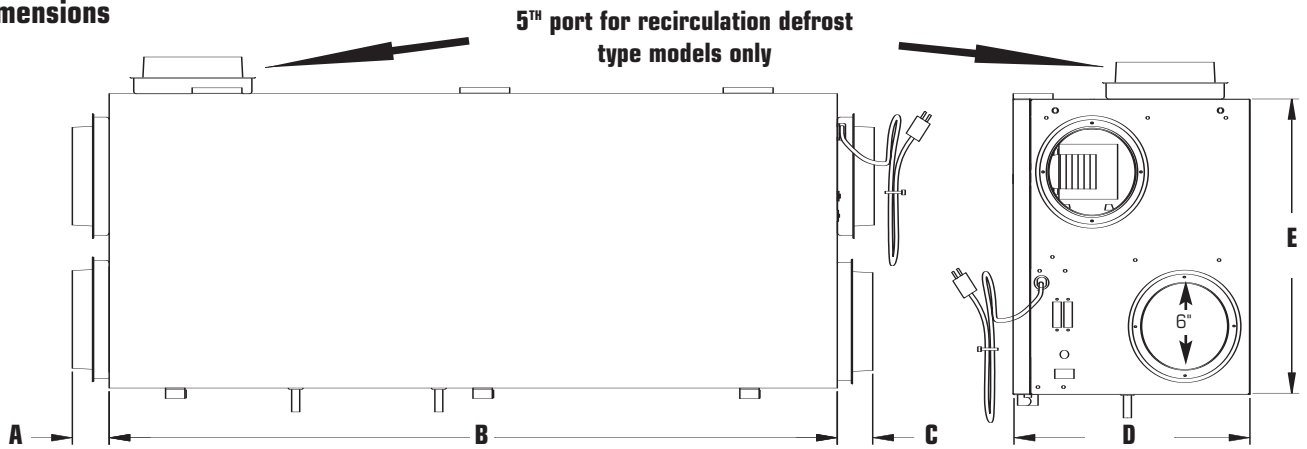

Model	A	B	C	D	E
SHR 3005R	2 1/4" (56mm)	50 7/8" (1292mm)	2 1/4" (56mm)	17 3/8" (441mm)	22 1/4" (564mm)
SHR 2005R(D)	2 1/4" (56mm)	27 7/8" (707mm)	2 5/8" (67mm)	17 3/8" (441mm)	20 1/2" (520mm)

## Fan Performance

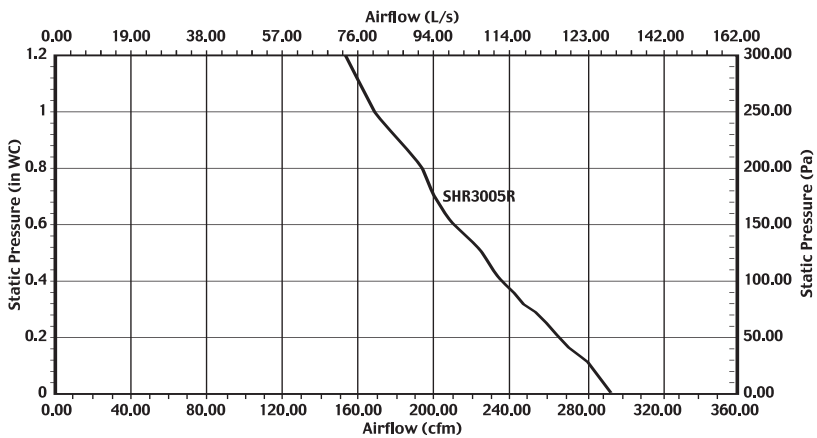

## Performance Data

Model	Apparent Sensible Effectiveness at 32°F (0°C)	Apparent Sensible Effectiveness at -13°F (-25°C)
SHR 3005R	92 %	91 %

AIRFLOW CAP. cfm (L/s) @ 0.4 on High Speed

Power	
• Volts	120 VAC
• Amperage	2.7 Amps Total
• Phase	Single Phase



## Airflow

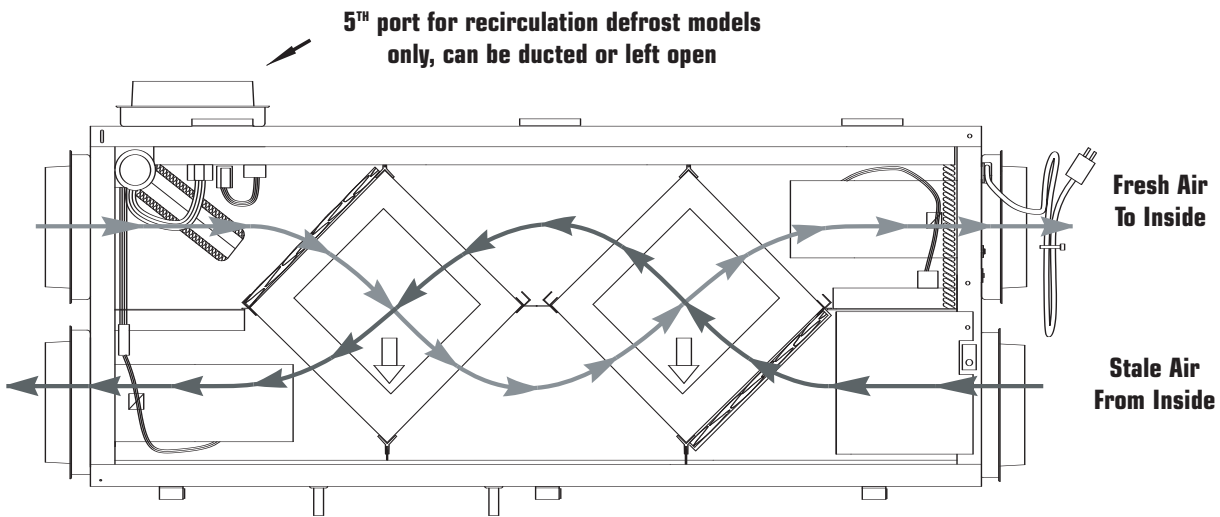

# SHR 3205RD Series HRV

## Dimensions

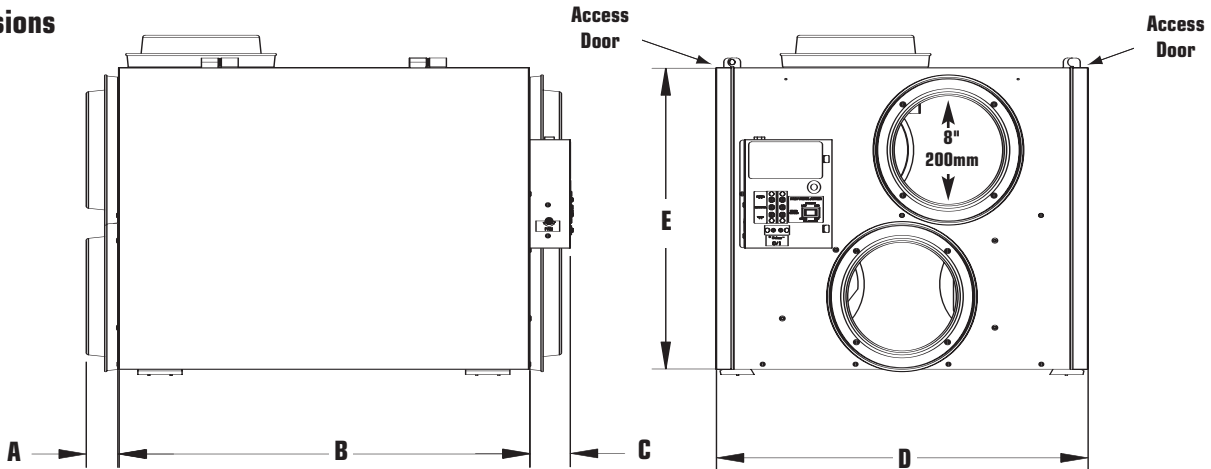

Model	A	B	C	D	E
SHR 3005R	2 1/4" (56mm)	27 7/8" (1292mm)	2 3/4" (71mm)	25 1/8" (638mm)	22 1/2" (520mm)
SHR 2005R(D)	2 1/4" (56mm)	27 7/8" (707mm)	2 5/8" (67mm)	17 3/8" (441mm)	20 1/2" (520mm)

## Fan Performance

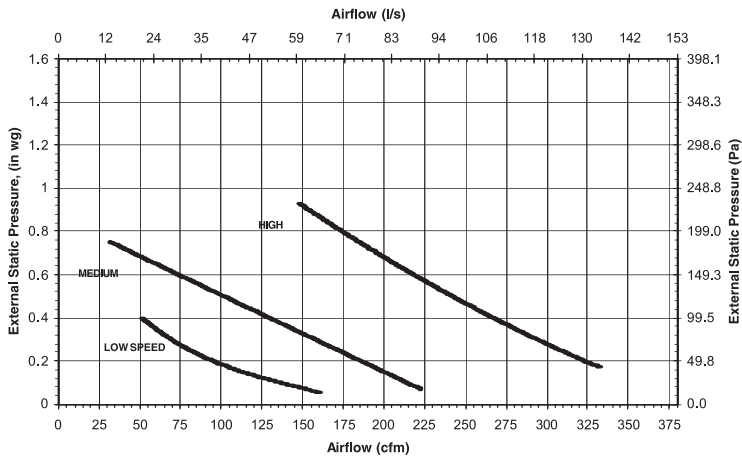

## Performance Data

Model	Apparent Sensible Effectiveness at 32°F (0°C)	Apparent Sensible Effectiveness at -13°F (-25°C)
SHR3205RD	72%	77%

AIRFLOW CAP. cfm (L/s) @ 0.4 on High Speed

### Power

- Volts
- Amperage
- Phase

120VAC  
2.5 Amps  
Single Phase



## Airflow

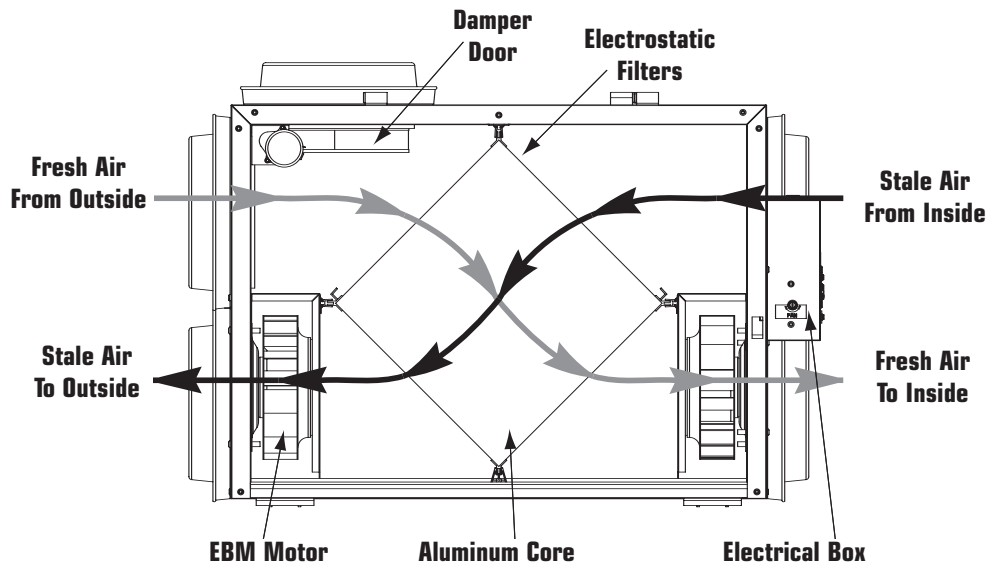

# VHR 1404, 1405R, 2004 & 2005R Series HRV

## Dimensions

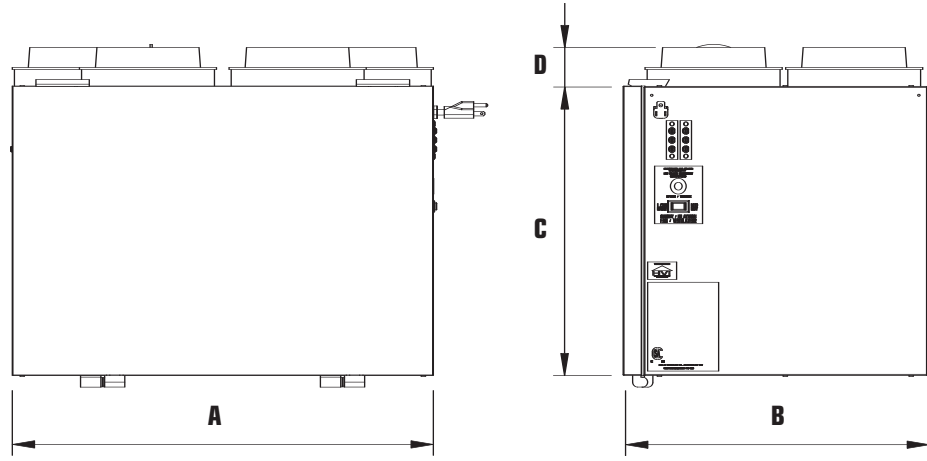

Model	A	B	C	D
VHR 1404	23 3/4" (604mm)	17 1/4" (438mm)	16 1/4" (413mm)	2 1/4" (56mm)
VHR 2004	28" (711mm)	17 1/4" (438mm)	20 1/2" (521mm)	2 1/4" (56mm)
VHR 1405R	23 3/4" (604mm)	17 1/4" (438mm)	16 1/4" (413mm)	2 1/4" (56mm)
VHR 2005R	28" (711mm)	17 1/4" (438mm)	20 1/2" (521mm)	2 1/4" (56mm)

## Fan Performance

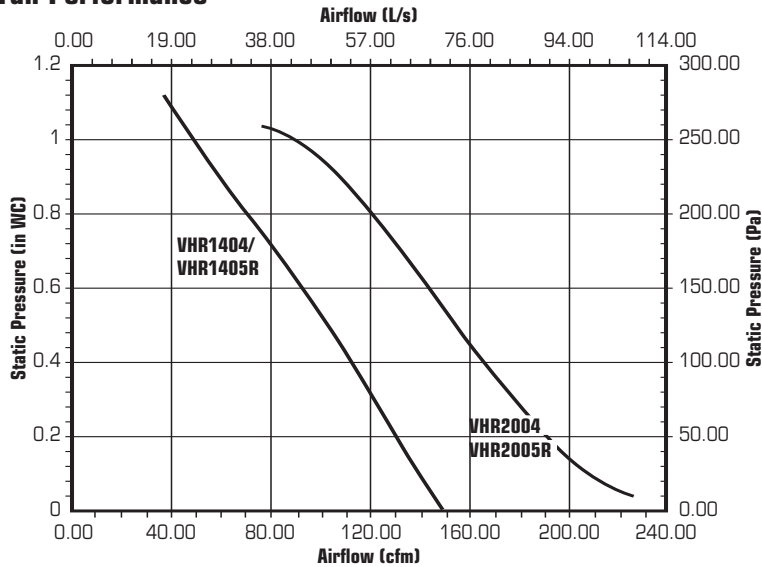

## Performance Data

Model	Apparent Sensible Effectiveness at 32°F (0°C)	Apparent Sensible Effectiveness at -13°F (-25°C)
VHR 1404/1405R	81 %	79 %
VHR 2004/2005R	71 %	76 %
VHR 1405R	81 %	79 %
VHR 2005R	71 %	76 %

AIRFLOW CAP. cfm (L/s) @ 0.4 on High Speed

### Power

- Volts 120VAC
- Amperage
  - VHR 1404/1405R 1.4 Amps
  - VHR 2004/2005R 1.6 Amps
- Phase Single



## Airflow

Optional recirculation duct collar (provided) with VHR 1405R & VHR 2005R only

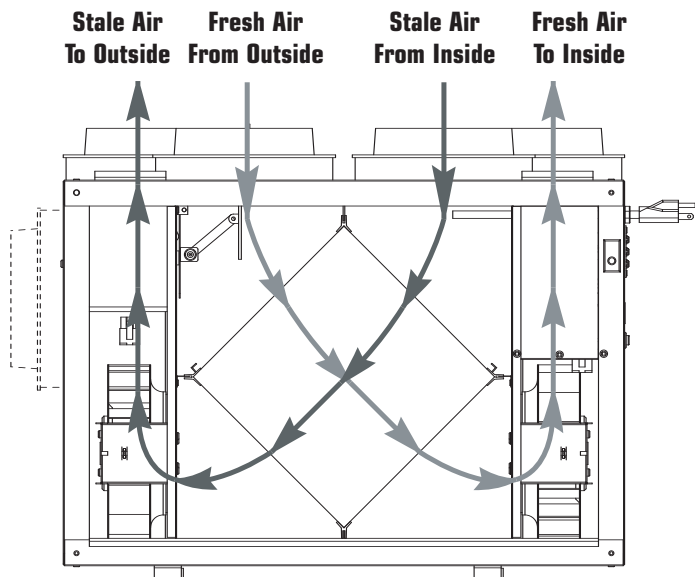

\* All collars on the VHR Series have a diameter of 6".

# MODES OF OPERATION

The entire line of SHR(D) / VHR / SER / VER series Heat Recovery & Energy Recovery Ventilators comes equipped with Fantech's new electronic uni-control board which offers a wide variety of features making it the ultimate ventilation control system. Fantech engineers have used the latest technology to provide solid, trouble free operation under any conditions.

The Fantech uni-control board offers stand alone operating capabilities as well as an exclusive 2 wire communication to most external controls. The trouble-free optional controls include: two different rotary dial dehumidistats, an air quality sensor (3 wire communication required), a 15 minute remote push-button timer, as well as the most sophisticated line of remote wall mounted controls, the Intellitek EDF5 (5MR).

An on-board diagnostic LED helps find problems quickly and efficiently. For example the LED can be used to signal a broken or shorted electronic wall control wire. Electronic air temperature probe gives this board accurate readings in order to minimize unnecessary defrost operation, and the on-board jumpers provide the user with the option of adjusting defrost time and sequence to optimize performance under abnormal conditions. The defrost operation is automatic and is usually never adjusted.

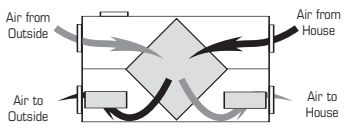
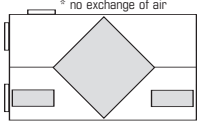
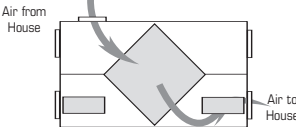
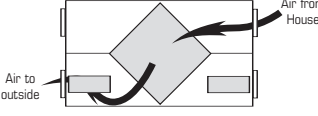
 <p><b>1. Continuous / Ventilation Mode</b></p> <p>In this mode of operation both fans are operating and exchanging air with the outside. The heat recovery ventilator (HRV) constantly exchanges the air at the rate you select, either at low or medium speed, and switches to high speed when activated by an optional remote control. The "Low" and "Med" fan speed selection will cause the unit to operate in continuous exchange mode at an exchange rate of 35% and 50% maximum airflow rating respectively. Continuous mode is recommended, since pollutants are slowly but constantly being generated in your house.</p>	 <p><b>2. Intermittent / Standby Mode (SHR(D) / VHR / SER / VER Series of HRV / ERV's)</b></p> <p>The system is always on standby and operates at high speed when activated by an optional remote control. "Standby" should be selected if the user wishes to stop the unit from continuous exchange. We recommend that the "Standby" mode only be used if your system is equipped with an optional external control, in which case, the unit would activate to "High" fan speed, until the control is satisfied and then return to standby (off).</p>
 <p><b>3. Defrost/Recirculation Mode (5 port "R" Models)</b></p> <p>The automatic defrost cycle SHR R(D) / VHR R models of HRV consists of a damper defrost which allows air to recirculate throughout the unit &amp; home. When the supply air stream temperature goes below -5°C (23°F), the exhaust motor shuts down, the supply motor goes to high speed, and a damper closes the supply, opening a 5th collar. The ambient air is then recirculated through the unit &amp; home for a period of 5 minutes. The unit will then resume normal operation for a time period of 25 minutes. This damper defrost cycle continues until the supply air stream rises above 0°C (32°F). The recirculation feature can be obtained with the use of an optional Intellitek EDF5 (5MR) control.</p>	 <p><b>4. Defrost (Fan shutdown 4 port models)</b></p> <p>The automatic defrost cycle SHR / VHR / SER / VER models of HRV / ERV's consists of a fan shutdown. When the supply air stream temperature goes below -5°C (23°F), the supply motor shuts down and the exhaust motor goes into high speed. Ambient air is passed through the unit for a period of 5 minutes. The supply motor will then re-start and run at the pre-set speed. The exhaust motor will also slow down to the preset speed, and the unit will operate in the run cycle for 25 minutes. This fan shutdown defrost cycle continues until the supply air stream rises above 0°C (32°F).</p>

**NOTE:** Some products may not be exactly as illustrated in the Installation, Operation and Maintenance Manual.

Fantech Inc. reserves the right to modify, at any time and without notice, any or all of its products' features, designs, components and specifications, to maintain their technological leadership position.



# INSTALLATION

## PRACTICAL TIPS

- Install the unit close to the outside wall on which the supply and exhaust hoods will be mounted.
- Have a nearby power supply 120 Volts, 60Hz.
- Have the possibility of mounting the unit to supporting beams.
- Mount the unit as level as possible in order to allow proper condensate drainage.
- Have access to a water drain for the condensate of the unit during defrost.
- Have a certain amount of heat around the unit (attic installation is not recommended).
- Minimize any noise level that would be created by the unit in the living area.
- Have access for future maintenance.

## LOCATION

The HRV must be located in a heated space where it will be possible to conveniently service the unit. Typically the HRV would be located in the mechanical room or an area close to the outside wall where the weatherhoods will be mounted. If a basement area is not convenient or does not exist, a utility or laundry room may be used.

Attic installations are not normally recommended due to:

- the complexity of work to install
- freezing conditions in the attic
- difficulty of access for service and cleaning

**Connecting appliances to the HRV** It is not recommended, including:

- clothes dryer
- range top
- stovetop fan
- central vacuum system

These appliance may cause lint, dust or grease to collect in the HRV , damaging the unit.

**NOTE:** Connecting any of these type of appliances to the HRV will invalidate your warranty

## MOUNTING



**1** Place Fastening hooks on the strapping board or the floor joists.



**2** Attach a hanging chain (provided) to each 10 3/4" (19 mm) bolt (provided) in the top 4 corners of the unit and tighten.



**3** Hang the unit by slipping a link onto the hanging hooks, making sure the unit is level.

## Installing Drain Line

Through normal operation and during its defrost mode, the HRV may produce some condensation. This water should flow into a nearby drain, or be taken away by a condensate pump. The HRV and all condensate lines must be installed in a space where the temperature is maintained above the freezing point. A "P" trap should be made in the drain line. This will prevent odors from being drawn back up into the unit.

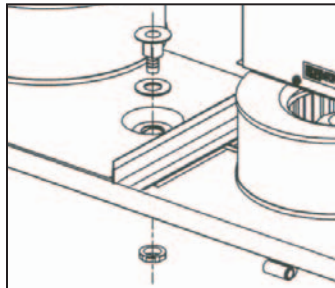

**1** Install the drain nipple.



**2** Install the drain hose, making a "P" trap

# INSTALLING DUCTS GOING TO / FROM OUTSIDE

## PRACTICAL TIPS

- Decide where your intake and exhaust hoods will be located.

### Locating the Intake Weatherhood

- Should be located upstream (if there are prevailing winds) from the exhaust outlet
- At least 6' (2m) away from dryer vents and furnace exhaust (medium or high efficiency furnaces)
- A minimum of at least 6' (2m) from driveways, oil fill pipes, gas meters, or garbage containers
- At least 18" (457mm) above the ground, or above the depth of expected snow accumulation
- At least 3' (1m) from the corner of the building
- Do not locate in a garage, attic or crawl space

### Locating the Exhaust Weatherhood

- At least 18" (457mm) above ground or above the depth of expected snow accumulation
- At least 3' (1m) away from the corner of the building
- Not near a gas meter, electric meter or a walkway where fog or ice could create a hazard
- Not into a garage, workshop or other unheated space

When installing the weatherhood, its outside perimeter must be sealed with exterior caulking.

A well designed and installed ducting system will allow the HRV to operate at its maximum efficiency. Always try to keep duct runs as short and straight as possible.

**See Installation Diagrams for installation examples.**

## INSTALLING THE DUCTING TO THE WEATHERHOODS

The inner liner of the flexible insulated duct must be clamped to the sleeve of the weatherhoods (as close to the outside as possible) and to the appropriate port on the HRV. The insulation should remain full and not be squished. The outer liner, which acts as a vapor barrier must be completely sealed to outer wall and the HRV using tape and or caulking. A good bead of high quality caulking (preferably acoustical sealant) will seal the inner flexible duct to both the HRV port and the weatherhood prior to clamping.

To minimize air flow restriction, the flexible insulated duct that connects the two outside weatherhoods to the HRV should be stretched tightly and be as short as possible. Twisting or folding the duct will severely restrict air flow.

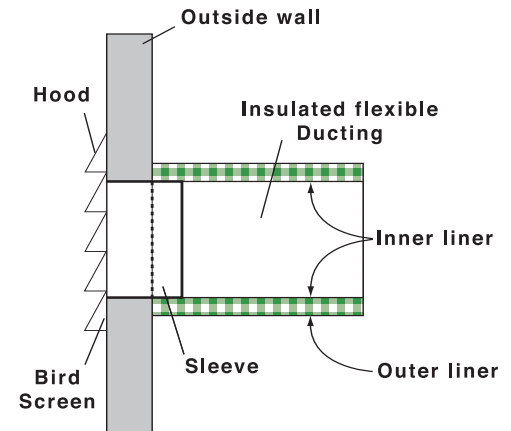

**1** Using the collar of the outside hood, outline the intake & exhaust holes to be cut. The holes should be slightly larger than the collar to allow for the thickness of the insulated flexible duct. Cut a hole for both the intake and exhaust hoods.



**2** Pull the insulated flexible duct through the opening until it is well extended and straight. Slide the duct's inner vinyl sleeve over the hood collar and secure, pull the insulation over the sleeve and secure with duct tape.



**3** Push the hood into the opening. Attach the hood to the outside wall with mounting screws. Repeat the installation procedure for both the Supply and Exhaust hood.

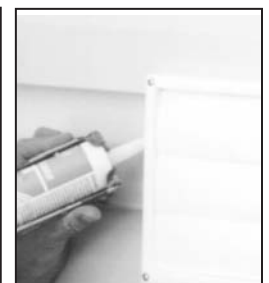

**4** Using a caulking gun, seal around both hoods to prevent any leaks.

# INSTALLING DUCTS TO / FROM INSIDE

To maximize airflow in the ductwork system, all ducts should be kept short and have as few bends or elbows as possible. Forty-five degree are preferred to 90° elbows. Use “Y” tees instead of 90° elbows whenever possible.

All duct joints must be fastened with screws or duct sealant and wrapped with a quality duct tape to prevent leakage. Aluminum foil duct tape is recommended. Galvanized ducting from the HRV/ERV to the living areas in the house is recommended whenever possible, although flexible duct can be used in moderation when necessary.

## SUPPLY AIR DUCTING

In homes without a forced air furnace, fresh air should be supplied to all habitable rooms including, bedrooms and living areas. It should be supplied from high wall or ceiling locations. Grilles that diffuse the air comfortably such as Fantech grille (MGE (metal) or PGE (plastic))s are recommended. To avoid possible noise transfer through the ductwork system, a short length (approximately 12”, 300 mm) of nonmetallic flexible insulated duct should be connected between the HRV/ERV and the supply/exhaust ductwork system. The main supply and return lines to/from the HRV/ERV must be 6 inches (150 mm) minimum. Branch lines to the individual rooms may be as small as 4 inches (100 mm), but 5 inch (125 mm) lines are preferred. If the floor is the only option available, then special care should be taken in locating grilles. Areas such as under baseboard heaters will help to temper the air. Also optional inline duct heaters are available for mounting in the supply duct work to add heat if required. In homes with a forced air furnace, you may want to connect the HRV/ERV to the furnace ductwork (see information below).

## Exhaust Air Ducting

The stale air exhaust system is used to draw air from the points in the house where the worst air quality problems occur. It is recommended that return air ducts be installed in the bathroom, kitchen, and laundry room. Additional return air ducts from strategic locations (i.e. greenhouse, atrium, swimming pool, sauna, etc.) may be installed. The furnace return duct may be also used to exhaust from. In this method, the exhaust air is not ducted back from bathrooms, kitchens, etc to the HRV/ERV with “dedicated lines”.

## DUCTING FIFTH PORT UNITS (R)

All SHR(D) / VHR / SER / VER Series R (1405R, 1505R, 2005R & 3005R) HRV / ERV's have a fifth duct port on top (SHR(D)/SER) or side (VHR/VER) of the unit. This duct port is for both defrost and the recirculation mode. A motorized damper installed in the port closes during defrost or recirculation temporarily blocking the incoming fresh air-stream, allowing the warm air from the house to circulate through the HRV / ERV. You may wish to duct this port to a common clean air room (living room or dining room) so when recirculation is activated, household odors from the kitchen, bathroom or basement won't be introduced into the living spaces of the home environment.

# INSTALLATION EXAMPLES

## Example diagram only-duct configuration may change depending on model

The recirculation function can be accessed with a optional EDF5 (5MR) intellitek control. It allows air to move gently throughout the home without exchanging air to the outside, until needed.

### Fully Dedicated System (new construction)

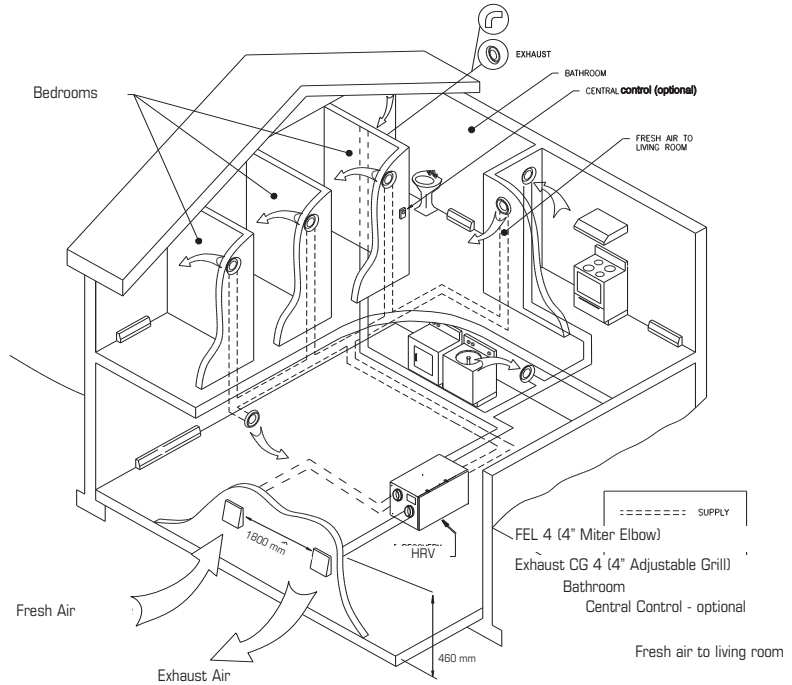

## Example diagram only-duct configuration may change depending on model

DIRECT CONNECTION of the SUPPLY AIR STREAM to the FURNACE COLD AIR RETURN  
(Stale air drawn from key areas of home)

### Partially Dedicated System

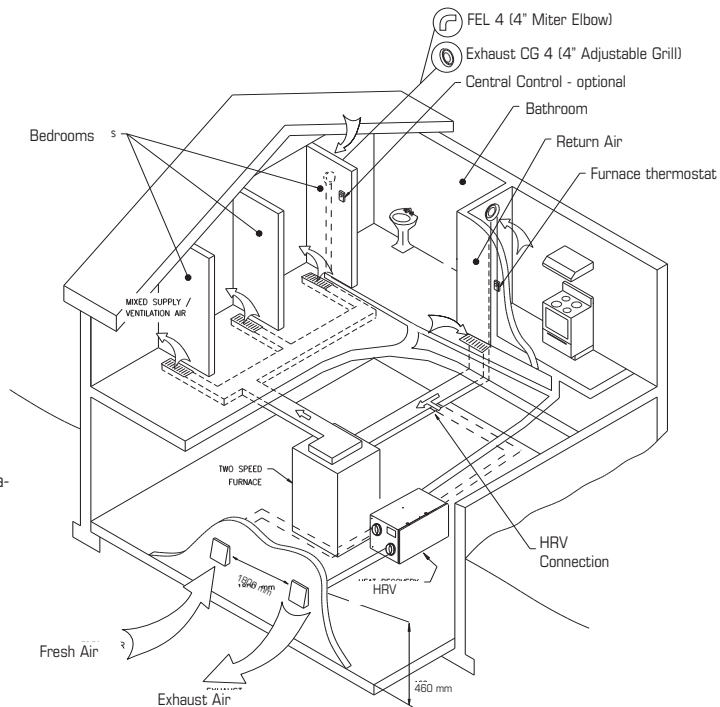

**NOTES:**

1. Furnace blower may be required to operate when HRV/ERV is on to provide good air distribution.
2. Weatherhood arrangement is for drawing purposes only. 6' (2m) minimum separation recommended. 18" (460mm) above grade minimum.
3. Due to the differences in pressure between the HRV/ERV and the equipment it is being connected to, the HRV/ERV's airflow must be confirmed on site, using the balancing procedure found in the installation manual.

# INSTALLATION EXAMPLES (CONT'D)

**Example diagram only-duct configuration may change depending on model**

DIRECT CONNECTION of both the HRV/ERV SUPPLY AIR STREAM and EXHAUST AIR STREAM to the FURNACE COLD AIR RETURN

## Simplified Installation

### Option 1 (Return/Return Method)

**NOTES:**

1. Furnace blower must operate when ventilation from HRV/ERV is required. The furnace should be set to run continuously or interlocked with HRV/ERV.
2. A minimum separation of 39 inches (1m) is recommended between the two direct connections.
3. The exhaust air connection should be upstream of the supply air connection to prevent exhausting any fresh air.
4. Weatherhood arrangement is for drawing purposes only.
5. Due to the differences in pressure between the HRV/ERV and the equipment it is being connected to, the HR/ERV's airflow should be confirmed on site, using the balancing procedure found in the installation manual.

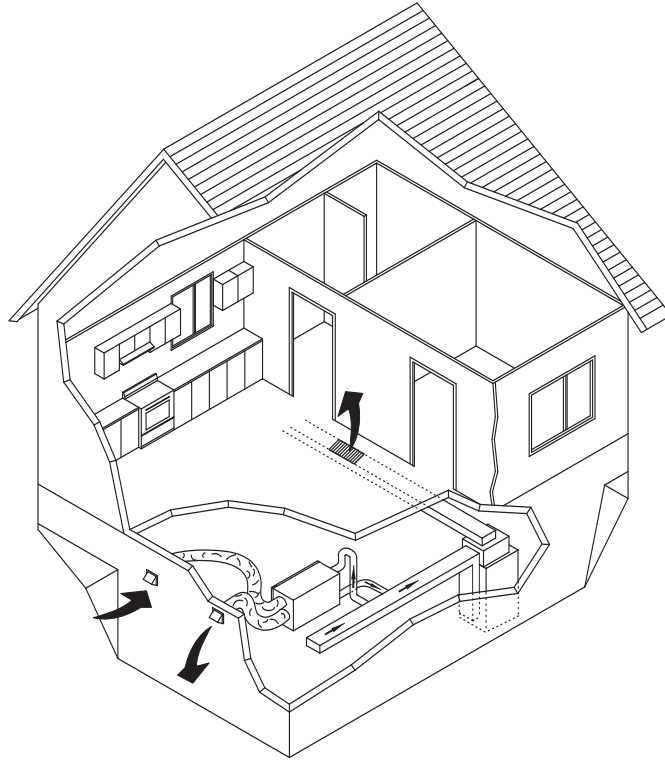

DIRECT CONNECTION of both the HRV/ERV SUPPLY AIR STREAM & EXHAUST AIR STREAM to the FURNACE COLD AIR RETURN & SUPPLY AIR SIDE

## Simplified Installation

### Option 2 (Supply/Return Method)

**NOTES:**

1. Furnace blower may be required to operate when ventilation from HRV/ERV is required. The furnace should be set to run continuously or interlocked with HRV/ERV.
2. The exhaust air connection should be upstream of the supply air connection to prevent exhausting any fresh air.
3. Weatherhood arrangement is for drawing purposes only. Six feet (2m) minimum separation recommended. Eighteen inches (460 mm) above grade minimum.
4. Due to the differences in pressure between the HRV/ERV and the equipment it is being connected to, the HR/ERV's airflow must be confirmed on site, using the balancing procedure found in the installation manual.

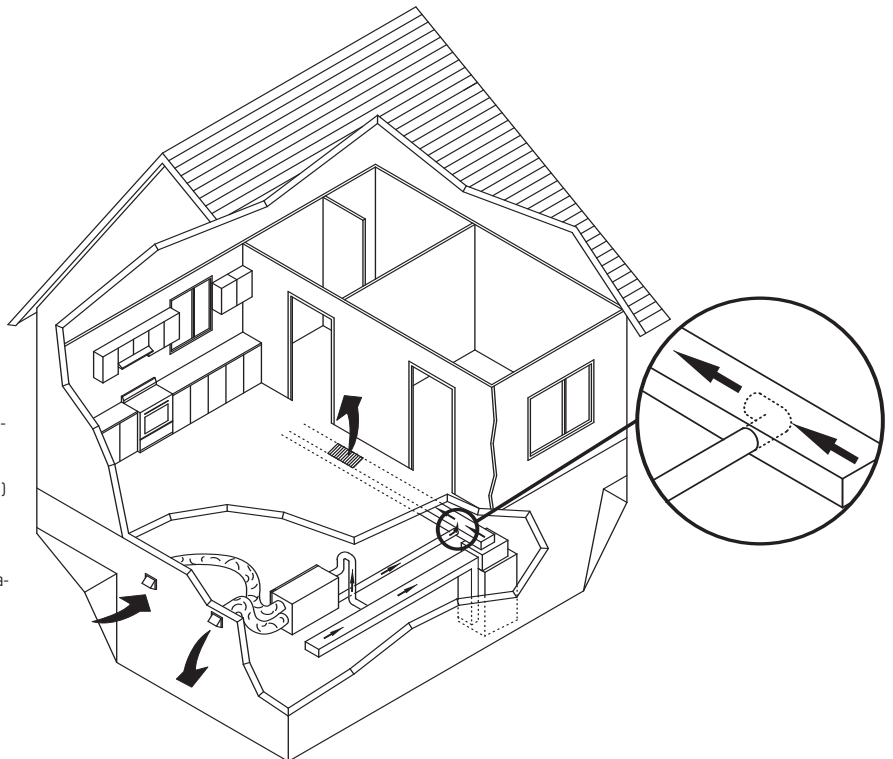

# AIR FLOW BALANCING

## AIRFLOW STATION (GRID) METHOD

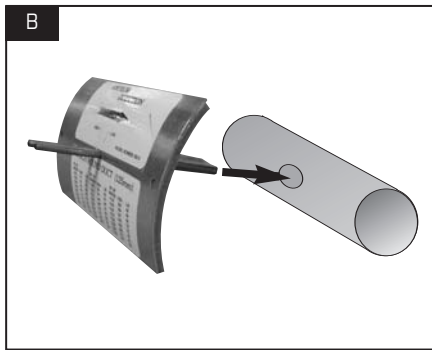

**1** For this flow measuring station, cut the duct and place the flow measuring station between each station. Make sure that the flow measuring station's air direction arrow points in the direction of the airflow. Secure the flow measuring station with duct tape.



**2** Before taking the reading, make sure that the magnehelic gauge is level and at 0. Refer to the flow measuring station's chart to determine your unit's airflow velocity.

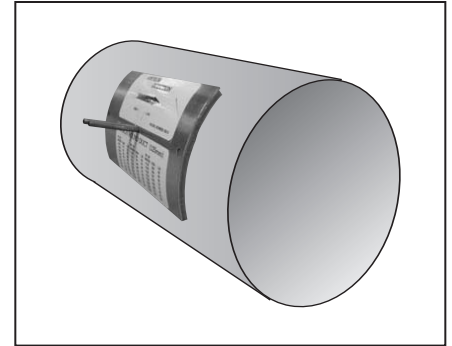

**3** Adjust the "Supply Air Out" damper until you reach the desired velocity. Follow the previous steps to adjust the "Exhaust Air Out" damper, if needed.

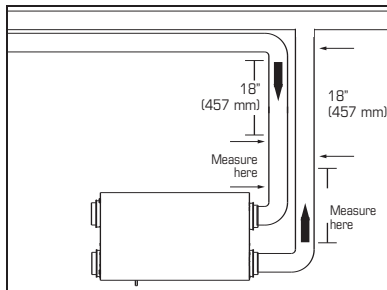

- To avoid airflow turbulence and incorrect readings, the airflow velocity should be measured on steel ducting a minimum of 18" (457 mm) from the unit or elbow and before any transition.

## ADJUSTING AIRFLOWS

### ELECTRONIC BALANCING MOTORS

(SHR 1505R(D), SHR 2005R, VHR 1405R & VHR 2005R only) -

*Motors will be factory set at their full potential depending on speed selected.*

When unit is installed you will need to balance the motors for proper operation.

Insert screwdriver and turn clockwise to slow down the motor, you will notice the motor changing speeds while performing this operation. Set to desired cfm.

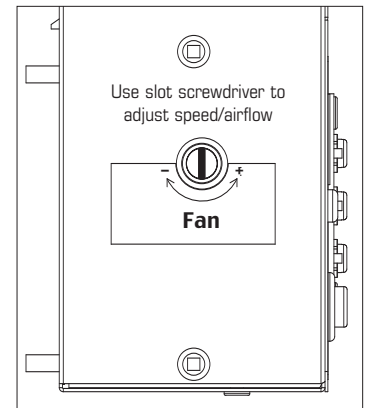

# ELECTRICAL CONNECTIONS

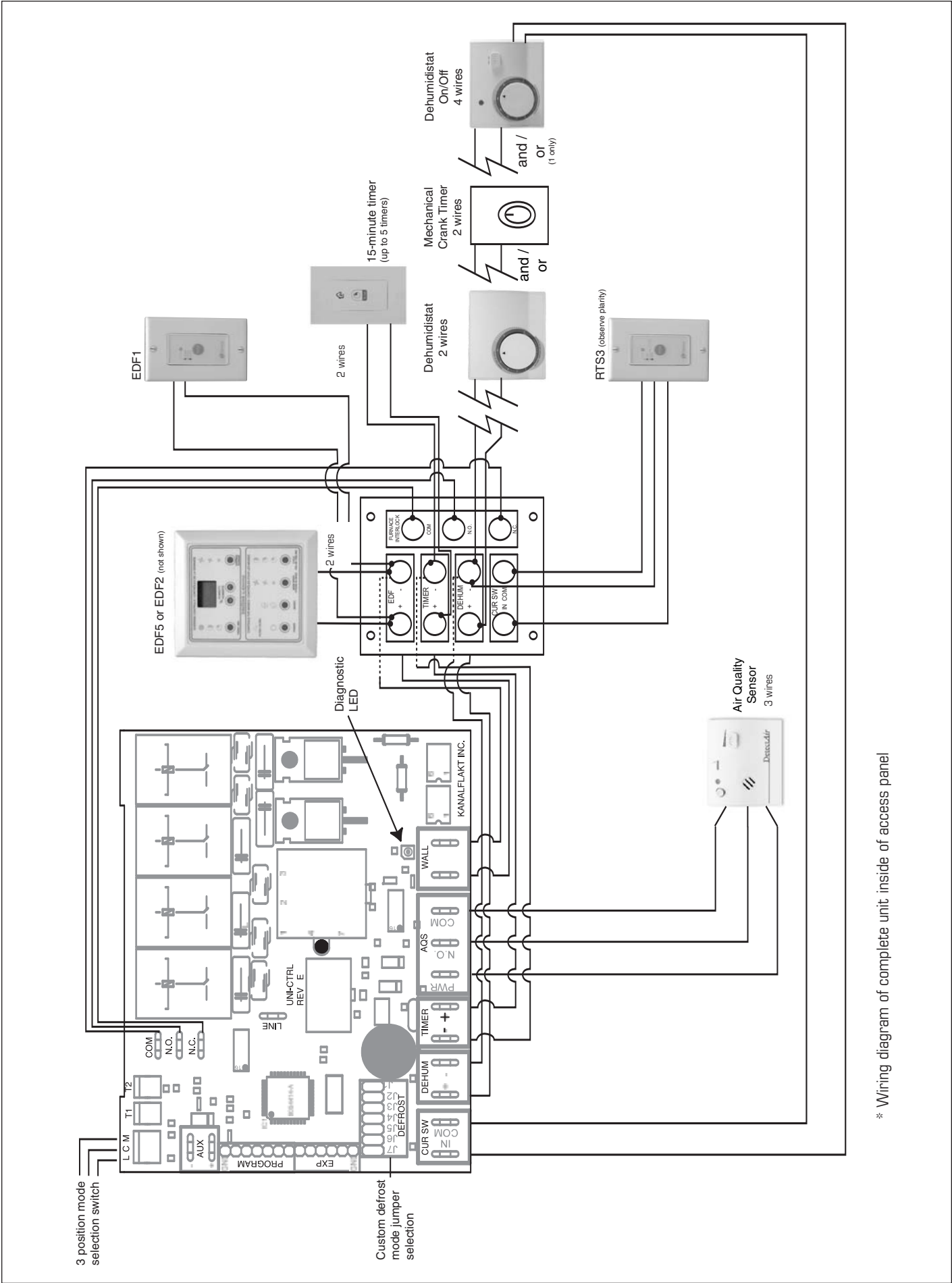

\* Wiring diagram of complete unit inside of access panel

# ELECTRICAL CONNECTIONS (CONT'D)

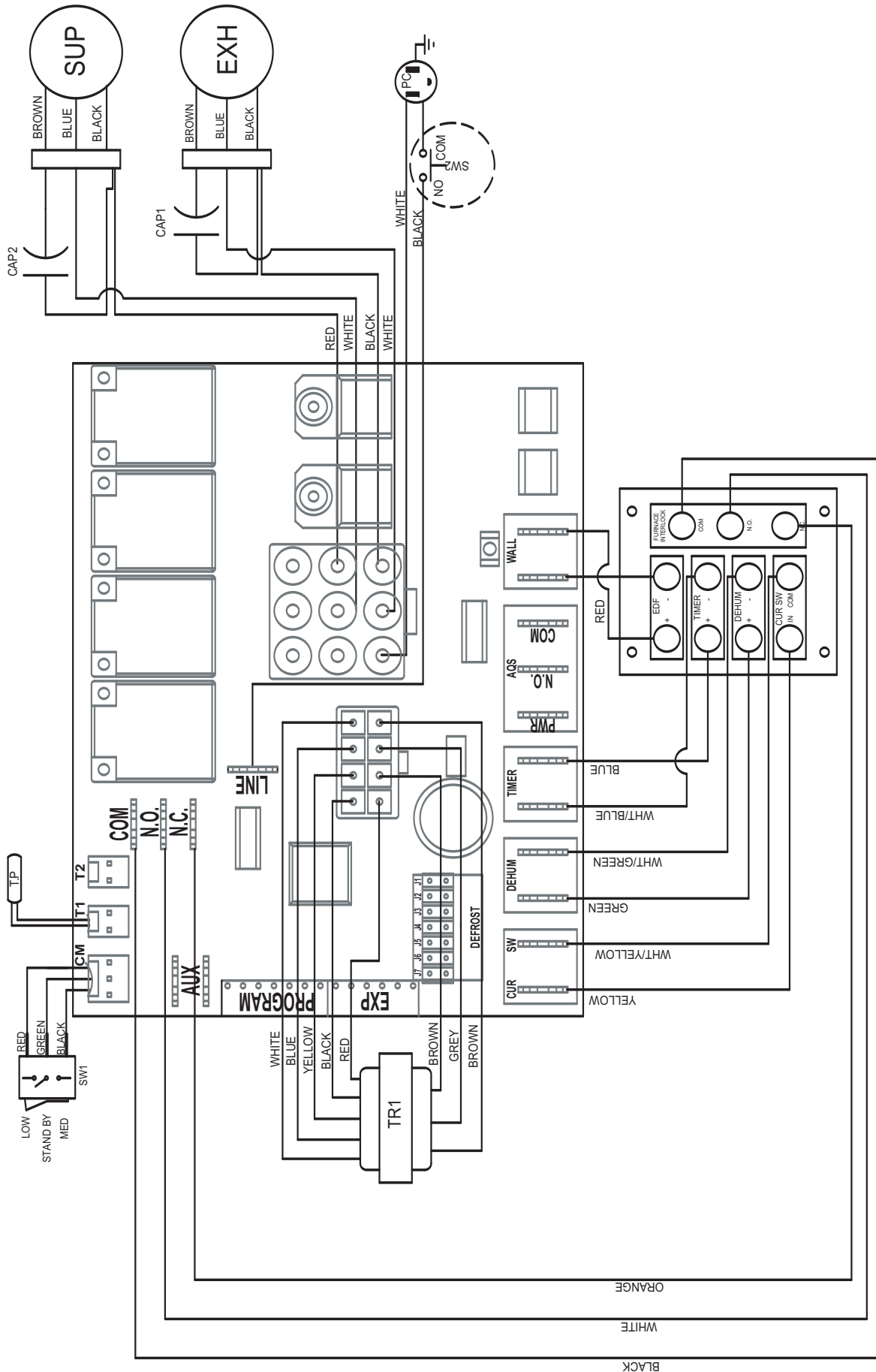









#### United States

1712 Northgate Blvd.,  
Sarasota, FL. 34234  
Phone: 800.747.1762;  
941.309.6000  
Fax: 800.487.9915; 941.309.6099  
www.fantech.net; info@fantech.net

#### Canada

50 Kanalfakt Way,  
Bouctouche, NB E4S 3M5  
Phone: 800.565.3548;  
506.743.9500  
Fax: 877.747.8116; 506.743.9600  
www.fantech.ca; info@fantech.ca

### The Best Limited Warranty in the Business

- The heat recovery polypropylene core has a limited lifetime warranty.
- The motors found in all Fantech HRV's & ERV's require no lubrication, and are factory balanced to prevent vibration and promote silent operation.
- The limited warranty covers normal use. It does not apply to any defects, malfunctions or failures as a result of improper installation, abuse, mishandling, misapplication, fortuitous occurrence or any other circumstances outside Fantech's control.
- Inappropriate installation or maintenance may result in the cancellation of the warranty.
- Any unauthorized work will result in the cancellation of the warranty.
- Fantech is not responsible for any incidental or consequential damages incurred in the use of the ventilation system.
- Fantech is not responsible for providing an authorized service centre near the purchaser or in the general area.
- Fantech reserves the right to supply refurbished parts as replacements.
- Transportation, removal and installation fees are the responsibility of the purchaser.
- The purchaser is responsible to adhering to all codes in effect in his area.
- The warranty is limited to 5 years on parts and 7 years on the motor from the date of purchase, including parts replaced during this time period. If there is no proof of purchase available, the date associated with the serial number will be used for the beginning of the warranty period.

\* This warranty is the exclusive and only warranty in effect relative to the ventilation system and all other warranties either expressed or implied are invalid.

Fantech, reserves the right to modify, at any time and without notice, any or all of its products' features, designs, components and specifications to maintain their technological leadership position.

Article #: 301038  
Item #: 401347  
Rev Date: 101805