

American Standard

Installation Instructions

R540

CERATHERM

3/4" CENTRAL THERMOSTAT WITH VOLUME CONTROL

Thank you for selecting American-Standard...the benchmark of fine quality for over 100 years.

To ensure that your installation proceeds smoothly—please read these instructions carefully before you begin.

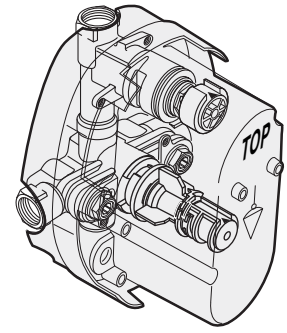

Certified to comply with ANSI A112.18.1M
ASSE 1016

M968480

ROUGHING-IN DIMENSIONS

CONNECTIONS ARE: 3/4" NPT

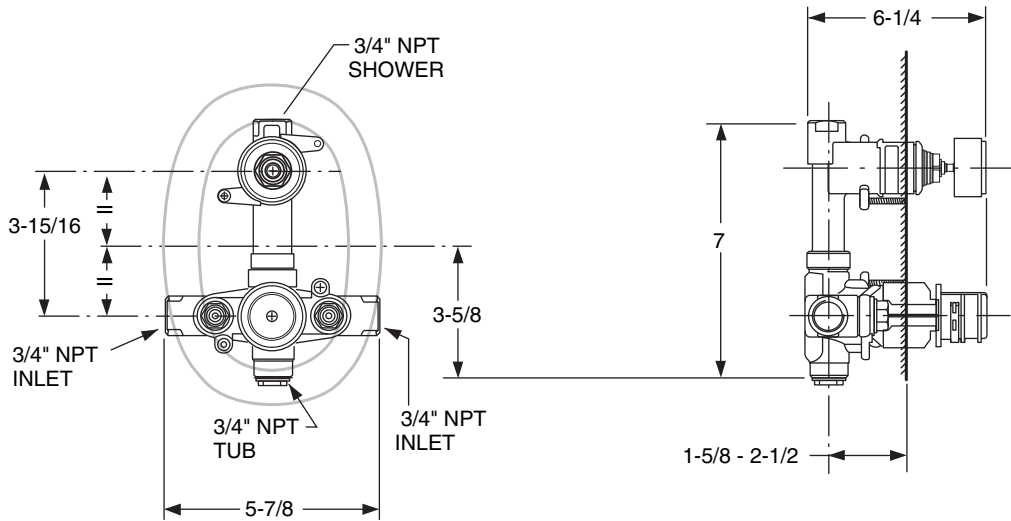

THERMOSTATIC BATH/SHOWER INSTALLATION USING A TWIN ELL, DIVERTER SPOUT AND FIXED SHOWER

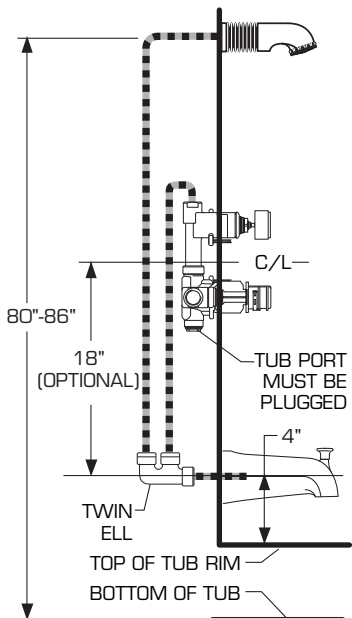

IMPORTANT: WHEN NOT USING A DIVERTER SPOUT A SEPARATE DIVERTER VALVE MUST BE USED.

THERMOSTATIC SHOWER INSTALLATION USING A DIVERTER VALVE, FIXED SHOWER HEAD AND ADJUSTABLE HAND HELD SHOWER

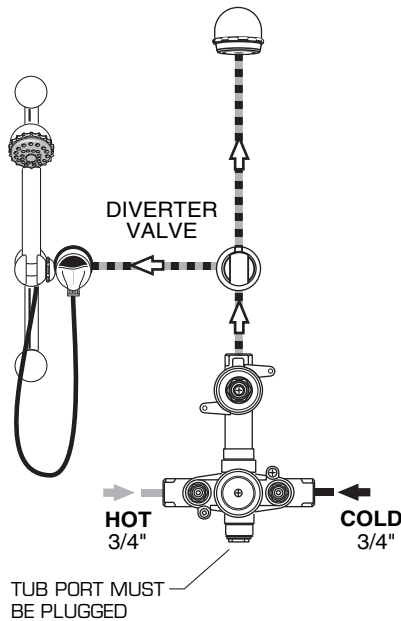

THERMOSTATIC SHOWER INSTALLATION USING A DIVERTER VALVE, FIXED SHOWER HEAD, ADJUSTABLE HAND HELD SHOWER, ON/OFF VALVE AND TWO BODY SPRAYS

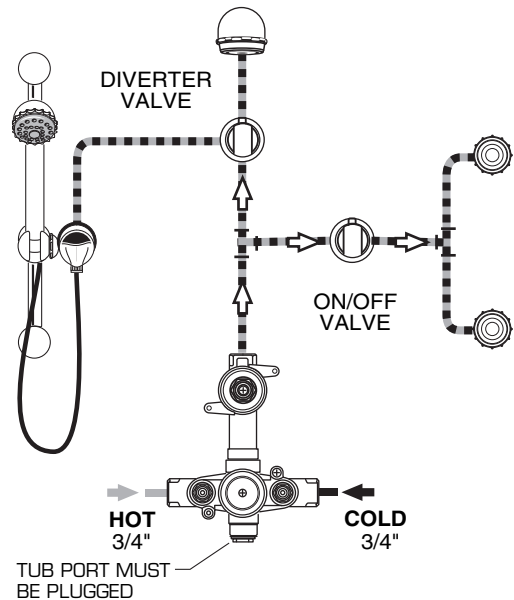

NOTE: MINIMUM FLOWING PRESSURE REQUIRED FOR THIS SYSTEM OPERATING WITH ONE SHOWER HEAD AND 2 BODY SPRAYS IS 40 PSI

1 ROUGHING-IN THE VALVE **WARNING** DO NOT SOLDER DIRECTLY TO THE VALVE BODY; THIS WILL DAMAGE THE TEMPERATURE CONTROL ELEMENT AND CHECK STOP VALVES.

- Prepare water supplies per ROUGHING-IN DIMENSIONS. Make sure the finished wall is between the minimum and maximum rough dimension.
- Install VALVE at indicated height and depth. Make sure the "TOP" marking on the PLASTER GUARD is up.
- Connect the hot and cold water supplies. Assemble all connecting pipes. Flush lines to remove any dirt. Connections are 3/4" NPT.
- Assemble the connection pipe to one of the MIXED OUTLETS of the VALVE. Cap the other MIXED OUTLET. (*Plug port is fitted with a plug at the factory.*)
- IMPORTANT! INSTALL ANY REQUIRED SHUT OFF OR DIVERTER VALVES INTO THE PIPING SYSTEM.
- If the CHECK STOPS (4, 5) were removed during installation, ensure the hot and cold CHECK STOPS (4, 5) are not reversed. The hot CHECK STOP (4) has a red top and the cold CHECK STOP (5) has a blue top.
- CHECK STOPS (4,5) are supplied in the open position. Closing using 5/32" (4 mm) hex wrench to pressure test and to check for leaks.
- To flush lines, remove the CHECK STOPS (4,5) and run water. If desired, the TEMPERATURE CONTROL UNIT can be removed. Reinstall CHECK STOPS (4,5) and CONTROL UNIT (6), if it was removed.
- Remove PLASTER GUARD (2) if still installed. Turn on water supplies and check for leaks.
- Reassemble PLASTER GUARD (2) and FINISH WALL.
- **Beware of Freezing.** No water should remain in the MIXING VALVE if freezing is a possibility. Remove the CHECK STOPS (4,5) to completely drain the MIXER UNIT (1).

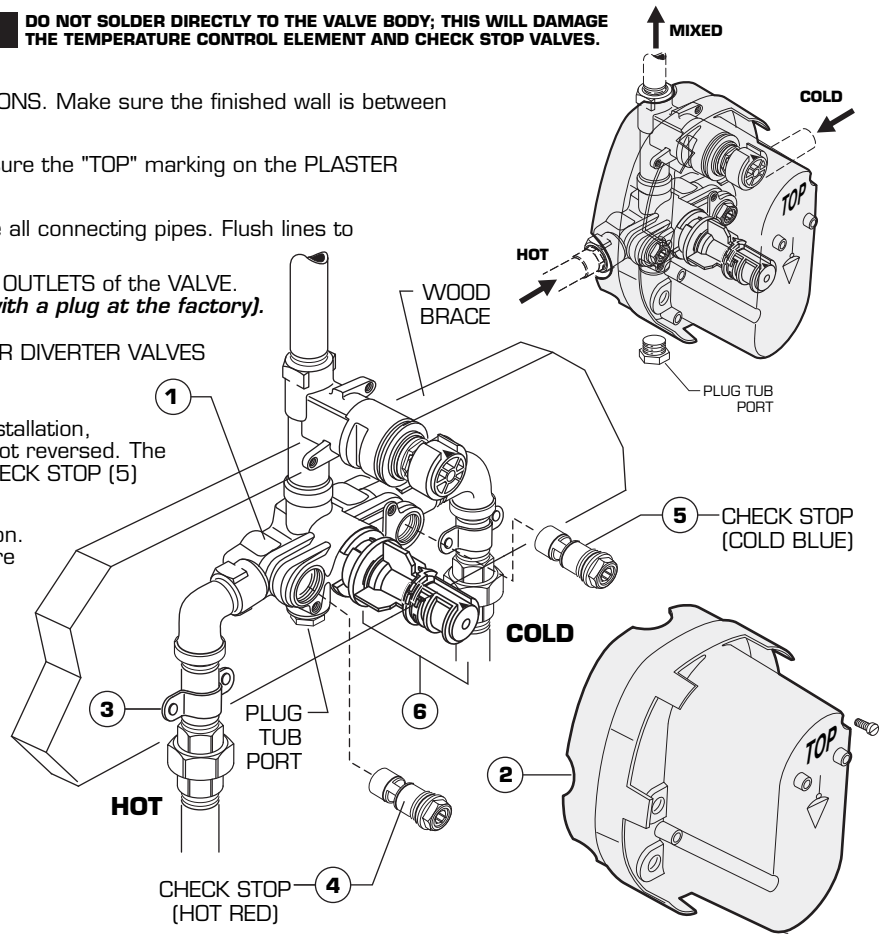

2 TEMPERATURE ADJUSTMENT

- Unscrew PLASTER GUARD SCREWS and remove PLASTER GUARD.
- Check that arrow marking B points vertically upwards. If not, push the BLACK CLAMP on the SECURING RING to the right, pull off KNOB MOUNT and reinstall KNOB MOUNT with arrow "B" pointing upwards.
- The maximum mixed water temperature is set at 109 F at the factory. This setting can be changed if desired.
- Remove the TEMPERATURE LIMIT STOP (H shaped Black Plastic part). Reinstall it at the desired notch as indicated in the diagram to limit the maximum mixed water temperature to 104 F or 112 F.
- For 100 F adjustment, turn the water supply on. Turn KNOB MOUNT until the spout temperature is 100 F. Check that arrow marking A on the KNOB MOUNT still points upward after adjusting the thermostat to 100 F. If not, pull out the RED LOCKING DEVICE. Remove KNOB MOUNT by pulling it towards you while standing directly in front of the valve.
- Reinstall the KNOB MOUNT so that the arrow marking A points upwards.
- Reinstall RED LOCKING DEVICE.

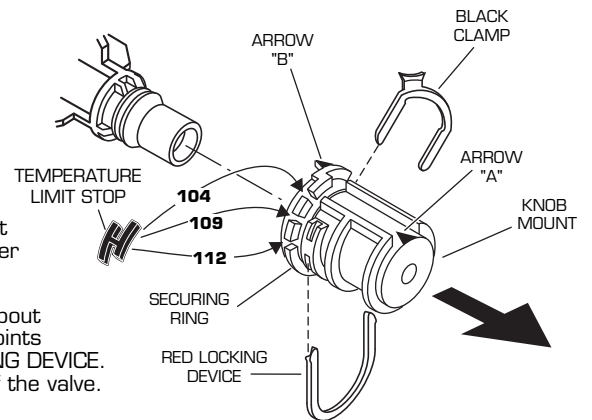

3 TRANSPOSED SUPPLY PIPING OR BACK TO BACK INSTALLATION

Should the hot and cold water supply pipes have been transposed making adjustment impossible, proceed as follows:

- Shut off water supply.
- Remove handle and rim
- Remove check stops and re-install them transposed.
- Important note: RED CHECK STOP is now on the right of the mixer body and the BLUE CHECK STOP is now on the left.
- Turn the water supply back on and perform the temperature adjustment in step 2.

