

# SUBMITTAL INFORMATION

## Ball Valve Curb Stop - Minneapolis Pattern - (B11-455M-NL style)

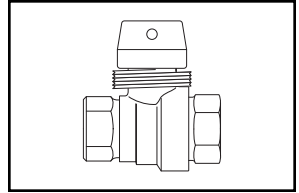

### FEMALE IRON PIPE THREAD INLET AND OUTLET

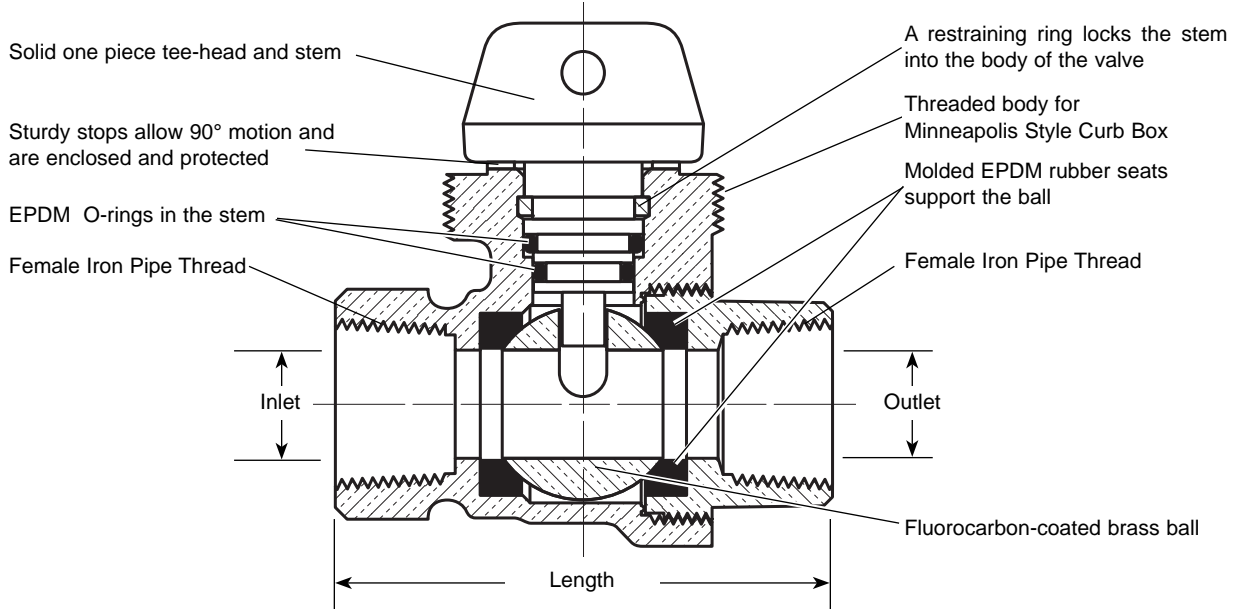

VALVE SIZE	INLET SIZE	OUTLET SIZE	LENGTH	APPROX. WT. LBS	PART NUMBER	✓SUBMITTED ITEM(S)
1"	1-1/4"	1-1/4"	4-7/16"	4.0	B11-455M-NL	

### FEATURES

- All brass that comes in contact with potable water conforms to AWWA Standard C800 (ASTM B584, UNS C89833)
- The product has the letters "NL" cast into the main body for lead-free identification
- Certified to NSF/ANSI Standard 61 and NSF/ANSI Standard 372 where applicable
- Brass components that do not come in contact with potable water conform to AWWA Standard C800 (ASTM B62 and ASTM B584, UNS C83600, 85-5-5-5)
- Valve is non-directional and is watertight with flow in either direction
- Ends are integral or secured with adhesive to prevent unintentional disassembly
- Hole for attaching curb box rod is provided in tee-head
- 300 PSI working pressure

Padlock Wing option is not available on the Minneapolis Pattern curb stop

**Optional full 360° tee-head rotation.** Add "R" to part number

The Ford Meter Box Company considers the information in this submittal form to be correct at the time of publication. Item and option availability, including specifications, are subject to change without notice. Please verify that your product information is current.



**The Ford Meter Box Company, Inc.**

P.O. Box 443, Wabash, Indiana U.S.A. 46992-0443

Phone: 260-563-3171 / Fax: 800-826-3487

Overseas Fax: 260-563-0167

www.fordmeterbox.com

04/20/15

Submitted By: