

## RESILIENT SEATED BUTTERFLY VALVE

FNW cartridge style resilient seated butterfly valves are designed to meet the rigorous requirements of industrial applications such as pulp and paper, water purification, power and utilities, chemical/petrochemical, food and beverage, OEM and HVAC. Each valve is manufactured in accordance with independent standards specifications and is 100% tested in both directions of operation to assure bubble-tight service for many years.

### Features:

- Designed for 125/150 lbs flanges
- Standard stainless steel disc and stem offer superior strength and chemical resistance
- Mounting pad with square shaft permits direct mount actuation that reduces hysteresis and cost (2" TO 12")
- Secured stem retainer plate for blowout-proof protection and also allows operator removal with valve in line
- High strength two-piece stem eliminates taper pins and disc screws from flow path
- Rated to 255 PSI (2"-12"), 188 PSI (14"-24")
- Cartridge style seat permits easy change without special tools
- Molded o-ring eliminates the need for flange gaskets\*
- Lockable Handles
- Shell tested to 150% and seat tested to 110% of maximum working pressure
- Lug bodies for dead-end service rated at 150 PSI\*\* (2"-12"), 100 PSI\*\* (14"-24")
- Wafer bodies cast iron to 10", ductile iron 12" to 24", and ductile iron lug bodies to 24"
- Lever operated to 12" or gear operated
- Dual PTFE shaft bearings for reduced torque and improved stem alignment
- Vacuum rated to 29.9196"Hg (0.01 Torr)†
- Epoxy coated body
- Low maintenance design
- Sizes 2" to 24"
- Lead Free Nonpotable

### Standards:

- Design: API 609A and MSS SP-67
- Seat Tested: MSS SP-61
- Top Flange: ISO 5211

### Options:

FNW offers many options and modifications for valves. These include, but are not limited to: Actuation including chain wheels, square drive nuts, worm-gear operators, and pneumatic and electric operators, control accessories, stem extensions, and custom mounting hardware. Contact FNW with your specific application



Fig. 731

Fig. 732

\* Pressed collar style angle face rings (typically sizes 2" to 6") are not recommended due to the large radius of the inner diameter. Cast type angle face rings or stub ends should be used with light wall stainless steel piping. Prior to installation, always verify that the connecting piping flange face fully engages the valve seat face.

\*\* Lugged valve for dead-end service and no downstream flange, may only be used with weld neck or socket flanges, for closed position only (no cycling).

† Vacuum measurements are often made in inches of mercury below atmospheric pressure. The values calculated here assume standard atmospheric pressure of 29.92 inches of mercury.

## 731 Wafer / 732 Lugged - Sizes 2" to 12" (also available with gear)

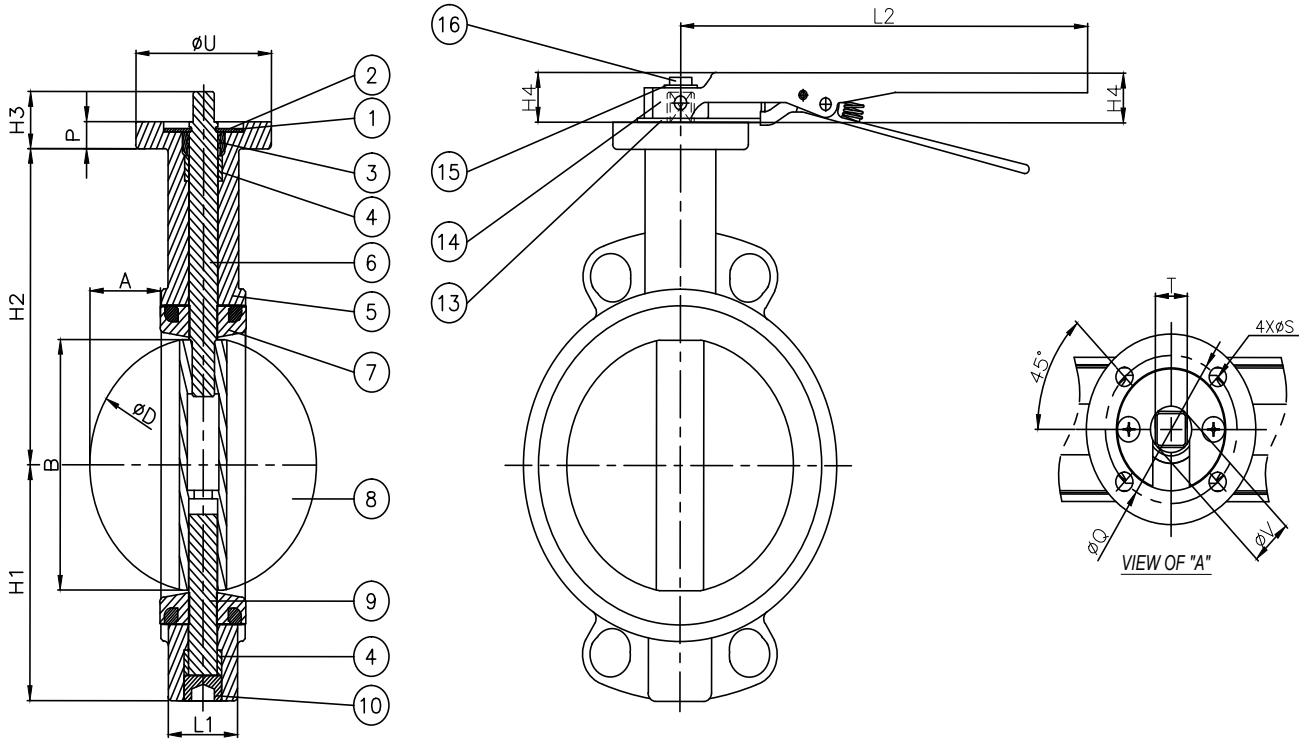

## 731 Wafer / 732 Lugged - Sizes 14" to 24"

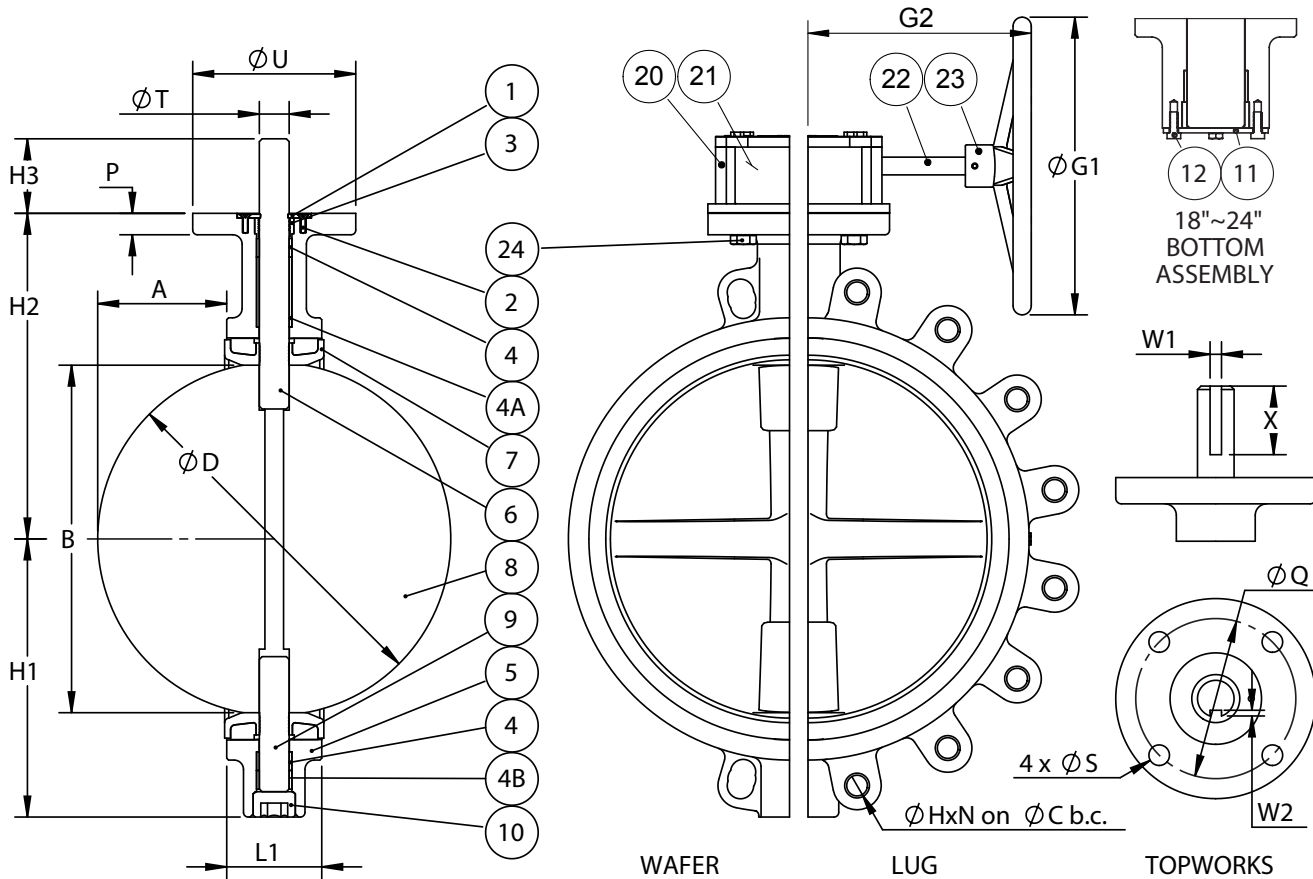

# Figure 731 & 732 BUTTERFLY VALVES



## Dimensions (Inches) Sizes 2 to 12

Size	A	B	ØD	H1	H2		H4	L1	L2	G1	G2	ØC	ØH	N	H3	ØU	P	ØQ	ØS	T	ØV
					731	732															
2"	0.18	1.93	2.05	2.77	5.06	4.94	1.06	1.69	11.37	5.79	6.22	4.75	5/8"-11	4	0.60	3.54	0.55	2.76	0.35	0.43	0.55
2-1/2"	0.41	2.52	2.64	2.95	5.36	5.20	1.06	1.81	11.37	5.79	6.22	5.49	5/8"-11	4	0.60	3.54	0.55	2.76	0.35	0.43	0.55
3"	0.67	3.03	3.15	3.67	5.64	6.07	1.06	1.81	11.37	5.79	6.22	6.00	5/8"-11	4	0.60	3.54	0.55	2.76	0.35	0.43	0.55
4"	0.94	3.82	3.94	4.18	6.41	6.54	1.06	2.05	11.37	5.79	6.22	7.50	5/8"-11	8	0.70	3.54	0.63	2.76	0.35	0.55	0.63
5"	1.36	4.80	4.92	4.69	7.34	7.13	1.06	2.20	11.37	5.79	6.22	8.50	3/4"-10	8	0.70	3.54	0.63	2.76	0.35	0.55	0.71
6"	1.86	5.83	5.93	5.48	7.98	7.84	1.06	2.20	11.37	5.79	6.22	9.51	3/4"-10	8	0.70	3.54	0.63	2.76	0.35	0.55	0.71
8"	2.69	7.62	7.74	6.51	9.34	9.26	1.06	2.36	17.83	11.81	8.07	11.75	3/4"-10	8	0.81	3.54	0.67	2.76	0.35	0.67	0.87
10"	3.52	9.62	9.72	7.86	11.13	10.50	1.02	2.68	17.83	11.81	8.07	14.25	7/8"-9	12	0.81	4.92	0.79	4.02	0.43	0.87	1.00
12"	4.28	11.54	11.63	9.47	12.27	12.15	1.02	3.07	17.83	11.81	8.46	17.00	7/8"-9	12	0.95	4.92	0.79	4.02	0.79	0.87	1.10

## Dimensions (Inches) Sizes 14 to 24

Size	A	B	ØD	H1	H2	G1	G2	L1	ØC	ØH	N	H3	ØU	P	ØQ	ØS	ØT	W1	W2	X
14"	4.96	12.83	12.99	10.41	13.60	11.81	8.46	3.07	18.75	1"-8	12	2.81	4.92	0.79	4.02	0.47	1.10	0.39	0.20	2.36
16"	5.45	14.82	14.92	11.75	13.76	11.81	8.86	4.02	21.25	1"-8	16	3.15	6.89	0.91	5.51	0.71	1.26	0.39	0.20	2.36
18"	6.36	17.09	17.20	13.78	15.75	15.55	8.86	4.49	22.75	1-1/8"-7	16	3.15	6.89	0.91	5.51	0.71	1.50	0.47	0.20	2.36
20"	7.15	19.13	19.29	14.96	17.32	15.55	10.12	5.00	25.00	1-1/8"-7	20	3.54	8.27	0.91	6.50	0.87	1.77	0.47	0.20	2.76
24"	8.28	22.46	22.62	17.32	20.08	15.55	10.12	6.06	29.50	1-1/4"-7	20	3.74	8.27	0.91	6.50	0.87	2.17	0.55	0.20	2.76

## Standard Materials

Ref. No.	Description	Material	Qty	Remarks
1	Retaining Plate	ASTM A283D-A36 STEEL	1	Galvanized
2	Retaining Plate Screw	ASTM A283D-A36 STEEL	2	Galvanized
			3	
3	Ingress Stem Seal	SAME AS SEAT MATERIAL	1	
4	Stem Bushing	PTFE	2	1 Upper, 1 Lower, Sizes 2"-3", 14"-24"
			4	2 Upper, 2 Lower, Sizes 4"-12"
4A	Upper Hard Bushing	ASTM B584 C83600 BRONZE	1	Sizes 14"-24"
4B	Lower Hard Bushing	ASTM B584 C83600 BRONZE	1	Sizes 14"-24"
5	Body	ASTM A126 CAST IRON	1	Fig 731, Sizes 2"-10"
		ASTM A536 65-45-12 DUCTILE IRON		Fig 731, Sizes 12" & Up, Fig 732 All
6	Upper Stem	ASTM A276 SUS 316 STAINLESS	1	
7	Seat	EPDM or BUNA	1	Sizes 2"-12" Only
		VITON®		
8	Disc	ASTM A351 CF8M, STAINLESS	1	
9	Lower Stem	ASTM A276 SUS 316 STAINLESS	1	
10	Plug	ASTM A283D-A36 STEEL	1	Sizes 2"-16"
11	Bottom Plate	ASTM A283D-A36 STEEL	1	Zinc Plated, Sizes 18"-24"
12	Bottom Plate Screw	ASTM A283D-A36 STEEL	4	Zinc Plated, Sizes 18"-24"
13	Lever Stop Plate	ASTM A283D-A36 STEEL	1	Nickel Plated, Sizes 2"-12"
14	Lever	ASTM A47 Gr 32510 MALLEABLE IRON	1	Sizes 2"-12"
15	Lever Washer	ASTM A283D-A36 STEEL	1	Zinc Plated, Sizes 2"-8"
16	Lever Bolt	ASTM A283D-A36 STEEL	1	Zinc Plated, Sizes 2"-8"
20	Gear Housing	ASTM A126 CAST IRON	1	Sizes 14"-24"
21	Gear Drive	ASTM A536 65-45-12 DUCTILE IRON	1	Sizes 14"-24"
22	Gear Input Shaft	STEEL	1	Nickel Plated, Sizes 14"-24"
23	Hand Wheel	ASTM A126 CAST IRON	1	Sizes 14"-24"
24	Gear Mounting Bolt	ASTM A283D-A36 STEEL	4	Zinc Plated, Sizes 14"-24"

Standard configurations are with levers up to 12" and gear operators 14" to 24. Gear operators for valves 12" and smaller are available upon request.

### Weight (Lbs)

Size	Wafer/Lever	Wafer/Gear	Lug/Lever	Lug/Gear
2"	8.1	17.8	10.6	20.3
2-1/2"	9.4	19.1	10.5	20.2
3"	9.6	19.4	11.2	21.0
4"	11.8	21.6	16.4	26.2
5"	16.0	25.8	21.1	30.9
6"	20.1	30.5	23.5	33.9
8"	34.1	46.5	38.0	50.4
10"	51.2	72.4	56.3	77.5
12"	66.7	87.9	85.6	106.8
14"	-	165.5	-	188.5
16"	-	260.5	-	336.5
18"	-	330.7	-	407.7
20"	-	507.7	-	614.7
24"	-	659.7	-	767.7

### Torque (In-Lbs)

Size	EPDM & BUNA Seat	VITON Seat
2"	367	477
2-1/2"	367	477
3"	480	624
4"	593	771
5"	649	844
6"	971	1,262
8"	1,896	2,465
10"	4,006	5,208
12"	4,627	6,015
14"	13,385	17,401
16"	17,506	22,758
18"	23,542	30,605
20"	29,076	37,799
24"	46,847	60,901

1. All unseating torques based on non-corrosive clean, wet or lubricating service at ambient temperatures. Contact FNW for dry or application specific torque.  
 2. For line velocities greater than 15 FPS, dynamic torque must be taken into consideration.  
 3. All torques are based on maximum pressure differential for the valve.

### Cv (Flow Coefficient)

SIZE	DEGREES of DISC OPENING							
	20°	30°	40°	50°	60°	70°	80°	90°
2"	8	9	18	28	55	72	110	135
2-1/2"	10	15	27	44	85	110	168	210
3"	15	23	39	65	130	165	250	310
4"	27	41	71	115	230	300	465	540
5"	58	86	150	245	480	610	980	1,100
6"	96	140	245	400	785	1,010	1,615	1,910
8"	165	245	410	685	1,275	1,715	2,670	3,185
10"	255	380	650	1,130	2,100	2,700	4,250	4,900
12"	370	540	950	1,570	3,050	3,950	5,950	7,350
14"	450	750	1,300	2,210	4,080	5,610	8,078	11,200
16"	640	900	1,720	2,790	5,000	7,650	10,770	12,900
18"	730	1,250	2,295	3,700	7,050	9,180	13,900	17,500
20"	910	1,595	2,850	4,630	8,600	11,500	17,540	22,400
24"	1,250	2,290	4,000	6,090	12,500	16,500	23,590	28,300

Cv is the volume of water in U.S. gallons per minute that passes through the valve at a pressure drop of 1 PSI at 68°F.

### Figure Number Matrix

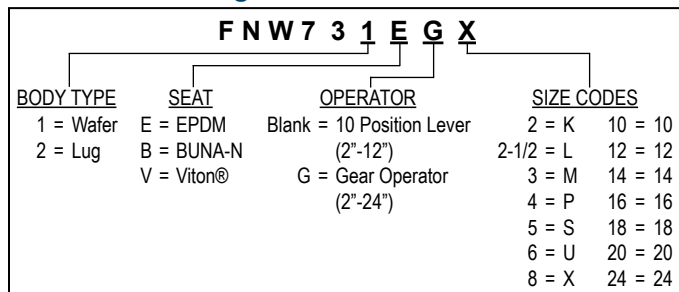

### Seat Temperatures

Seat Material	Working Temperature
EPDM	-22° to 230°F (-30°C to 110°C)
Buna-N	-4° to 194°F (-20°C to 90°C)
Viton®	-14° to 320°F (-25°C to 160°C)

DOC: FNW731-732V08 Ver. 03/2017

© 2017 - FNW. All rights reserved.

The FNW logo is a trademark of Ferguson Enterprises, Inc., PL Sourcing, PO Box 2778, Newport News, VA 23609

The contents of this publication are presented for information purposes only, and while effort has been made to ensure their accuracy, they are not to be construed as warranties or guarantees, expressed or implied, regarding the products or services described herein or their use or applicability. All sales are governed by our terms and conditions, which are available on request. We reserve the right to modify or improve the designs or specifications of our products at any time without notice. Always verify that you have the most recent product specifications or other documentation prior to the installation of these products.