

Model ZW206

Solenoid Control Valve (4" and Larger)

Globe and Angle Pattern Bodies



❑ Installation ❑ Troubleshooting ❑ Maintenance Instructions

Installation / Start-up

INSTALLATION

NOTE: Flushing of all pipe lines is to be performed to remove all debris prior to installing valve.

1. For making adjustments and servicing allow for adequate space around the valve before installing valve.
2. When installing a ZW206 valve, gate valves installed (a minimum of one pipe diameter apart) on both inlet and outlet are recommended for maintenance allowing for isolation of the valve.
3. Position the ZW206 in line matching the direction of flow as indicated on the valve model tag with the proper direction of flow in the system. Once attached to line, double check all fasteners/bolts in the pilot system and on main valve are tight and there is no damage prior to pressurizing system. **NOTE: Pressure in some applications can be very high so be thorough in checking and inspecting for proper installation and makeup.**
4. Zurn Wilkins valves are designed to operate in both the vertical and horizontal positions. However, it is recommended that ZW206 6" and larger, be installation in the horizontal position. The horizontal positioning of the larger valves avoids premature wear due to the mass of plunger assemblies as well as allows for greater accessibility during annual inspections, and maintenance.
5. Be sure to comply with all local and national electrical codes when wiring the solenoid control.

START-UP

CAUTION: To prevent personnel injury and damage to equipment check that downstream venting is adequate prior to start-up and test procedures. All adjustments under pressure should be made slowly while under flowing conditions. If the main valve closes too fast it may cause surging in upstream piping.

1. Open isolation valves (2) in the pilot system (see ZW206 schematic).
2. Then slowly open the upstream shutoff valve only enough to fill main valve assembly and pilot system. Prior to pressurizing the valve assembly it is also recommended that a ZPI valve position indicator be installed to aid in verifying proper valve movement.
3. As the valve is filling with water, it is necessary to bleed the main valve and pilot system of air. To vent air, partially open or loosen the highest plugs or fittings in the system. The ZPI valve position indicator is a great location, as it has a test cock at the top to vent air pressure. It may be necessary to bleed system more than once. After removal of air in the system tighten all loose fittings.

NOTE: If valve is installed vertically, it will be necessary to loosen some upper cover bolts until you have vented all the air from the cover chamber.

4. If valve is equipped with speed controls (O or L on ZW206 schematic) it is necessary to back out the set screw a minimum of 3 turns from initial set point.
5. Next it is advisable to flow water through the valve to ensure all air has escaped from system. It will be necessary to either energize or de-energize the solenoid to open the valve depending on the option installed.
6. With the upstream shutoff valve partially open, slowly open the downstream shut off valve. Flow will begin to occur and pressure should build up in valve and eventually stabilize.
7. Verify operation of the valve by energizing or de-energizing the solenoid to open and close the valve.

8. Once operation of the valve is verified, the speed controls if installed can be set. When setting speed controls, turning the adjustment screw into the speed control body will restrict the amount of flow through the needle valve. Depending on whether the control is for opening or closing (refer to ZW206 schematic) the control will either slow the opening or closing of the main valve when the adjustment screw is turned into the speed control. Adjust as needed and tighten jam nut. In general a closing speed control on a ZW206 should be at least 3 turns in from the furthest open position to prevent high pressure surges upstream.

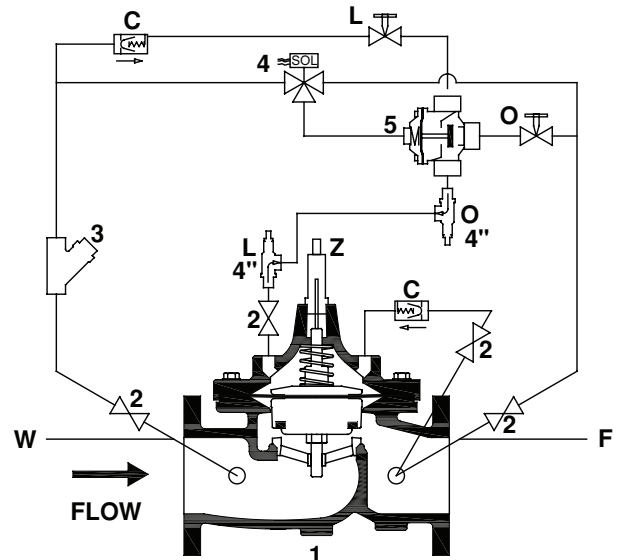
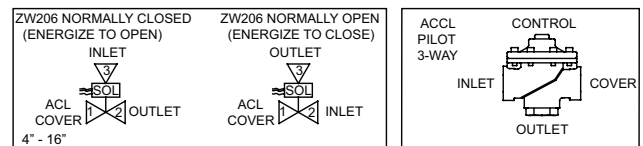

SCHEMATIC DIAGRAM

STANDARD COMPONENTS

1. Main Valve
2. 850MXL Isolation Valve
3. SXL Wye Type Strainer
4. PPV-SOL3 3-Way Solenoid Cntrl.
5. 3-Way Accelerator Pilot

OPTIONAL FEATURES

- C 40XL Hydraulic Check w/Isolation Valve
- L SC1 Closing Speed Control
- O SC1 or SC2 Opening Speed Control
- Z ZPI Visual Position Indicator

Troubleshooting

OPERATION

The following troubleshooting information in Tables 1 & 2 deals strictly with the ZW206 valve and pilot system. It is recommended to verify that the pilot system is properly functioning before troubleshooting the main valve. All troubleshooting can be performed without removing the cover. It is also recommended to permanently install a model ZPI valve position indicator and an additional gauge in one of the cover connections.

Troubleshooting

SOLENOID/PILOT SYSTEM FUNCTION CHECK

CAUTION: During testing of solenoids electrical voltages are required. Extra care should be taken when handling and testing to avoid personnel injury and damage to valve. Prior to disassembling pilot or main valve be sure to cut all power to solenoid.

1. To verify if the solenoid is properly functioning, first determine which solenoid option is on the valve. Refer to Valve Catalog No. on solenoid name plate and voltage stamped on side of green coil.
2. After determining which solenoid voltage is required, apply required voltage to energize solenoid. You should hear an audible "Click" when the solenoid opens and closes. If there is no audible "Click" inspect all wiring in the system and solenoid for possible damage (See Table 6.)
3. To verify if the entire pilot system is operating correctly open the upstream gate valve and slowly pressurize entire valve.

Close the outlet ball valve to close the ACV. If installed, verify the valve position indicator (model ZPI) is closed.

4. Proceed with venting outlet downstream pressure by opening a source downstream. When opening the downstream source if there is continuous flow, the main valve is not sealing properly. It is recommended that the main valve be disassembled and inspected (Refer to "Disassembly" section).
5. If the main valve is sealing, test the pilot by energizing or de-energizing the solenoid to close the main valve. With the solenoid set to close the ACV, open the outlet ball valve. If there is continuous flow through the ACV now, either the accelerator pilot or solenoid are not sealing properly. It is recommended to check the solenoid and accelerator pilot for damage. Refer to troubleshooting for the solenoid and accelerator pilot.

TABLE 1. SOLENOID / PILOT SYSTEM TROUBLESHOOTING

<u>PROBLEM</u>	<u>POSSIBLE CAUSES</u>	<u>CORRECTIVE ACTION</u>
1. Solenoid Valve not Opening /Closing	<ol style="list-style-type: none"> 1. Lost electrical signal to solenoid 2. Clogged "Wye" Strainer 3. Closed Ball Valves 4. Incorrect voltage at solenoid 	<ol style="list-style-type: none"> 1. Replace or repair any damaged wiring or replace Solenoid 2. (See plugged "Wye" Strainer remedy) 3. Open ball valve 4. Supply correct voltage stamped on coil or replace coil.
2. "Wye" Strainer plugged	<ol style="list-style-type: none"> 1. Clogged with debris or mineral deposits 	<ol style="list-style-type: none"> 1. Disassemble and remove obstruction

TABLE 2. ACCELERATOR TROUBLESHOOTING

<u>PROBLEM</u>	<u>POSSIBLE CAUSES</u>	<u>CORRECTIVE ACTION</u>
1. ACL does not seal on upper seat	<ol style="list-style-type: none"> 1. The spring is over compressed 2. Foreign matter obstruction between diaphragm assy. and bell or seat and plunger 3. Cut, worn or chipped plunger seal or seat 4. Damaged diaphragm or stem o-rings 5. ACL bell port is clogged 	<ol style="list-style-type: none"> 1. Disassemble and remove obstruction 2. Disassemble and remove obstruction, replace parts as necessary 3. Replace with new plunger or seat. 4. Disassemble and replace diaphragm or o-ring 5. Remove obstruction
2. ACL does not seal on lower seat	<ol style="list-style-type: none"> 1. Weak or no spring compression 2. Cut, worn or chipped plunger seal or seat 3. Damaged diaphragm or stem o-rings 4. Foreign matter between plunger or stem guide and lower seat 5. ACL bell port is clogged 6. Loose diaphragm nut 	<ol style="list-style-type: none"> 1. Check and replace spring as needed 2. Replace with new plunger or seat. 3. Disassemble and replace diaphragm or o-ring 4. Disassemble and remove obstruction 5. Remove obstruction 6. Disassemble and re-tighten the diaphragm nut
3. Leakage from valve	<ol style="list-style-type: none"> 1. Damaged diaphragm or lower seat o-ring 2. Ports not sealed 	<ol style="list-style-type: none"> 1. Disassemble and replace damaged part as needed 2. Remove and reinstall port fittings with Teflon tape or pipe sealant

TABLE 3. MAIN VALVE TROUBLESHOOTING

<u>PROBLEM</u>	<u>POSSIBLE CAUSES</u>	<u>CORRECTIVE ACTION</u>
1. Main Valve fails to open	1. No pressure at valve Inlet 2. Main valve diaphragm assembly inoperative 3. Pilot Valve (Solenoid) not opening 1) Lost electrical signal to Solenoid 2) Damaged Solenoid	1. Check Inlet pressure 2. Disassemble, clean, and polish stem, replace defective parts 1. Inspect all wiring and replace as needed 2. Disassemble and replace as needed
2. Main Valve fails to close	1. Lost electrical signal to solenoid 2. Damaged Solenoid 3. Foreign matter between disc and seat or worn disc 4. Scale on stem or diaphragm ruptured 5. "Wye" Strainer plugged 6. Closed Ball Valve/s	1. Inspect all wiring and replace as needed 2. Disassemble and replace as needed 3. Disassemble the main valve, remove debris, clean parts, and replace defective parts 4. Clean parts, and replace defective parts 5. Remove, clean, and/or replace 6. Open Ball Valves

When performing troubleshooting and diagnosis checks it is recommended that the following steps be performed in sequential order for best results.

DIAGNOSIS CHECKS

CAUTION: Do not service valve while under pressure. When performing diagnosis checks on the ZW206 when the valve is fully open, high flow rates and high downstream pressures can occur. In order to prevent harm to personnel, equipment, and downstream piping be sure that there are no blocked valves in the system before performing checks.

DIAPHRAGM CHECK

1. Slowly close upstream shut off valve and relieve all pressure downstream.
2. With all pressure relieved in the main valve, close both pilot inlet and outlet ball valves on the main valve and remove side plug on cover and leave off.
3. Then open upstream shut off valve partially, allowing water to flow through the valve. While flowing water, monitor the opening on the cover. If fluid begins to flow out of the open hole on the cover, then there is most likely damage to the diaphragm or fluid is leaking past the diaphragm assembly due to a loose assembly. It is recommended that the valve cover be removed to investigate the leakage (To remove cover see "Maintenance" section for procedures). If no water flows out of cover then the diaphragm is good and you may proceed to the diaphragm movement check.

DIAPHRAGM MOVEMENT CHECK

1. The diaphragm movement check can be determined during the diaphragm check or it can also be performed with the use of a valve position indicator model ZPI.
2. Replace cover plug and open pilot ball valves on inlet and cover.
3. Opening the inlet and cover ball valves will direct the flow to the cover causing it to close. **NOTE: Slow or delayed closing of main valve is normal. This is due to time to fill, pressurize cover, and stretch the diaphragm into the closed position. This normal delay is not binding of the valve assembly.**
4. It may be necessary to energize the solenoid to close if ZW206 option is "Normally Open".
5. Using the valve position indicator make note of the closed position on the indicator. Compare distance of the open mark to the close mark and compare to Table 3.
6. Verify that the main valve is closed, by opening a downstream source (not the outlet isolation ball valve on the main body). If water continuously flows, then the main valve is not sealing properly. Double check the valve movement matches the values in Table 3 and refer to the disassembly procedures section if it does not. This is an indication that the main valve

is not sealing due to an obstruction between the seat and the seal or a damaged seal. If water does stop flowing and the measured valve movement does not match Table 3, then there is possible damage under the cover. Remove cover to identify obstruction and replace parts as necessary.

TABLE 3. VALVE STEM TRAVEL

VALVE SIZE (in)	VALVE SIZE (mm)	STEM TRAVEL (in)	STEM TRAVEL (mm)
1-1/4" - 1-1/2"	38	0.4	10.2
2"	50	0.7	18.0
2-1/2"	65	0.8	21.3
3"	80	0.9	23.4
4"	100	1.1	28.8
6"	150	1.7	43.4
8"	200	2.4	59.7
10"	250	2.8	71.1
12"	300	3.4	86.4
14"	350	3.8	96.5
16"	400	4.3	109.2

7. For smaller valves (6" and below) diaphragm checks can be performed by hand with the use of a valve stem tool. The valve stem tool can be made using Table 4 to create a "T" bar handle with the appropriate threads on the opposite end of the "T" handle.

8. To perform the diaphragm check using the valve stem tool, first remove all pressure in the system and vent the cover. Then remove the center plug on the cover and insert tool into the top of the stem threads. Once the tool is inserted, the valve can be lifted up and the valve movement can be measured by creating

marks on the tool in the opened and closed positions. Replace or repair any parts as necessary.

TABLE 4. VALVE STEM THREAD SIZE

VALVE SIZE (in)	THREAD SIZE UNF INTERNAL
1-1/4" - 1-1/2"	10-32
2"	10 - 32
2-1/2"	10 - 32
3"	1/4 - 20
4"	1/4 - 20
6"	1/4 - 20
8"	3/8 -16
10"	3/8-16
12"	3/8-16
14"	3/8-16
16"	3/8-16

SEAL CHECK

1. To check the seal of the valve disc, an additional pressure gauge will be needed downstream of main valve.
2. With the valve flowing slowly close pilot outlet ball valves to apply pressure to cover and allow to close. If the solenoid option is "Normally Closed" the solenoid will have to be energized to open and allow flow to cover.
3. Monitor the pressure on the inlet and installed outlet gauge. The pressure on the outlet side should be zero. If the pressure matches inlet pressure, the main valve is leaking or the outlet ball valve on the pilot system is allowing pressure to creep by. Either way it is recommended that the valve be disassembled and inspected (refer to "Disassembly" section).

Maintenance Instructions

PREVENTATIVE MAINTENANCE

The Zurn Wilkins ZW200 Models requires minimal maintenance. However, it is highly recommended to schedule annual inspections and to have a repair kit before disassembly work begins.

Disassembly

Warning: With the ability to perform inspections. And maintenance without removal from the system, it is very important that all shut off valves be closed and all pressure relieved in the valve before beginning disassembly. Failure to do so can result in personnel injury or equipment damage.

1. Verify that all pressure sources are closed, up and downstream of valve.
2. Remove pressure in pilot system by loosening the tube fittings to the valve body and cover. When all pressure has been vented, continue to disassemble the pilot control valve and cover tubing. NOTE: Taking a picture before tear down can help with re-assembly of pilot system.
3. Next remove the cover by loosening and removing the cover bolts. If the cover does not come off easily it may be necessary to loosen the cover using a brass chisel and rubber mallet. Apply the chisel under the cover pointing upward away from valve body and tap bottom of cover with the chisel and mallet to loosen the cover. Once the cover is loose, pull cover straight up to avoid damaging the stem and stem bearing in the cover.
4. With the cover removed, the diaphragm assembly can be removed. To avoid damaging the seat bushing, grab the stem and lift straight up. For larger valves 8" and up it is recommended that

an eye bolt with the proper stem threads be used with a hoist to lift the assembly out of the valve (see Table 3 for appropriate stem threads).

5. Next it is recommended that the diaphragm assembly be placed in a vise with the bottom hex nut secured. Once secured remove the spring and stem nut. While removing the nut inspect the stem threads. Clean stem with a wire brush if mineral deposits or corrosion are present.
6. After inspecting the stem and removing the nut the diaphragm assembly can be dismantled. If the valve has not been serviced in awhile it is possible that the assembly will require the use of a rubber mallet or pry bars to dismantle the assembly. If this is the case gently tap or pry the components until the components are free to move. When disassembling be sure to clean, inspect, and save all components. Replace any damaged components as necessary.
7. The last component to inspect is the seat which is in the body of the main valve. During inspection of the seat, clean and polish as necessary with fine grit wet/dry sandpaper (400 grit or higher). Typically, after cleaning there is no visual damage or excessive wear the seat should not require removal. If damage is present or the seat is excessively worn the seat should be replaced.
8. To remove the seat, on valves 6" and smaller the seat is threaded into the body and will require a seat removal tool. Care should be taken when removing the seat to avoid damaging.

INSPECTION OF COMPONENTS

Cleaning of components is required for proper inspection. Lime deposits are common in systems that use water. To remove

deposits fine grit wet/dry sandpaper (400 grit or higher) can be used. If deposits cannot be removed, off the shelf lime deposit remover can be used. Prepare a solution following the lime deposit remover instructions and soak components (**excluding rubber components**) until lime deposits are removed. **CAUTION: When handling chemicals (acids) be sure to use proper safety equipment (gloves and eye protection) and practices. After soaking components, be sure to thoroughly rinse all components before handling and re-assembling valve.**

Once all valve components have been cleaned, inspect each component looking for damage, abnormal wear & corrosion, and replace all components that look questionable. Replace all rubber components including the diaphragm, o-rings and disc each time the valve is serviced or inspected (rubber components are standard in ZW200 repair kits).

REASSEMBLY

1. First reinstall seat into body. Be sure to use lube around seat o-ring before tightening. Tighten seat according to torque values in Table 5 using seat tool.
2. Next place valve stem in a vise clamping on the hex portion of the stem. Then assemble the diaphragm assembly as shown. When assembling be sure that the diaphragm is centered on the raised step of the disc retainer. It is also recommended to apply lube to stem threads and o-rings before tightening. Then tighten the stem nut according to Table 5 for torque values.
3. Lower diaphragm assembly carefully into the seat bearing. Be careful not to damage the seat or stem while installing assembly. Rotate the assembly as needed until the bolt holes on the diaphragm line up with the body bolt holes.
4. Place lower spring disc on the diaphragm disc and place spring on top of the assembly. Then install cover, aligning the bolt holes and insuring that the cover is not pinching the diaphragm between the bolt holes.
5. Install cover bolts and tighten in a star pattern to the torque values in Table 5.

TABLE 5. VALVE TORQUE SETTINGS

VALVE SIZE (in)	COVER (ft-lbs)	DIAPHRAGM ASSEMBLY (ft-lbs)	THREADED SEAT (ft-lbs)	SEAT BOLTS (ft-lbs)
1-1/4"	3.5	7.5	11	N/A
1-1/2"	3.5	7.5	11	N/A
2"	15	20-25	30	N/A
2-1/2"	25	25-35	60	N/A
3"	25	35-45	70	N/A
4"	55	40-50	85	N/A
6"	110	50-60	95	N/A
8"	120	60-70	N/A	7.4
10"	184	70-75	N/A	7.4
12"	200	110-115	N/A	7.4
14"	275	170-175	N/A	7.4
16"	360	230-240	N/A	7.4

6. Before installing center cover plug manually check that assembly has full operating travel before installing the pilot assembly (refer to "Diaphragm Movement" in the diagnosis checks section).
7. Once full operation range of the main valve is verified begin reinstalling pilot system.
8. After installing pilot system double check that all plugs, bolts, and fittings are sealed and tight before applying pressure.

9. Slowly open upstream isolation valve to pressurize the system and check for any leaks.
10. Stop leaks as needed and proceed to "Start-Up" and "Diagnosis Check" sections for returning valve to proper system operations.

TABLE 6. SOLENOID OPTIONS

WILKINS SOLENOID PN	DESCRIPTION	VOLTAGE
PV-SOL3-NO	SOLENOID FOR NORMALLY OPEN ZW206 (ENERGIZE TO CLOSE)	120vac
PV-SOL3-NC	SOLENOID FOR NORMALLY CLOSED ZW206 (ENERGIZE TO OPEN)	120vac
PV-SOL3-24NO	SOLENOID FOR NORMALLY OPEN ZW206 (ENERGIZE TO CLOSE)	24vac
PV-SOL3-24NC	SOLENOID FOR NORMALLY CLOSED ZW206 (ENERGIZE TO OPEN)	24vac

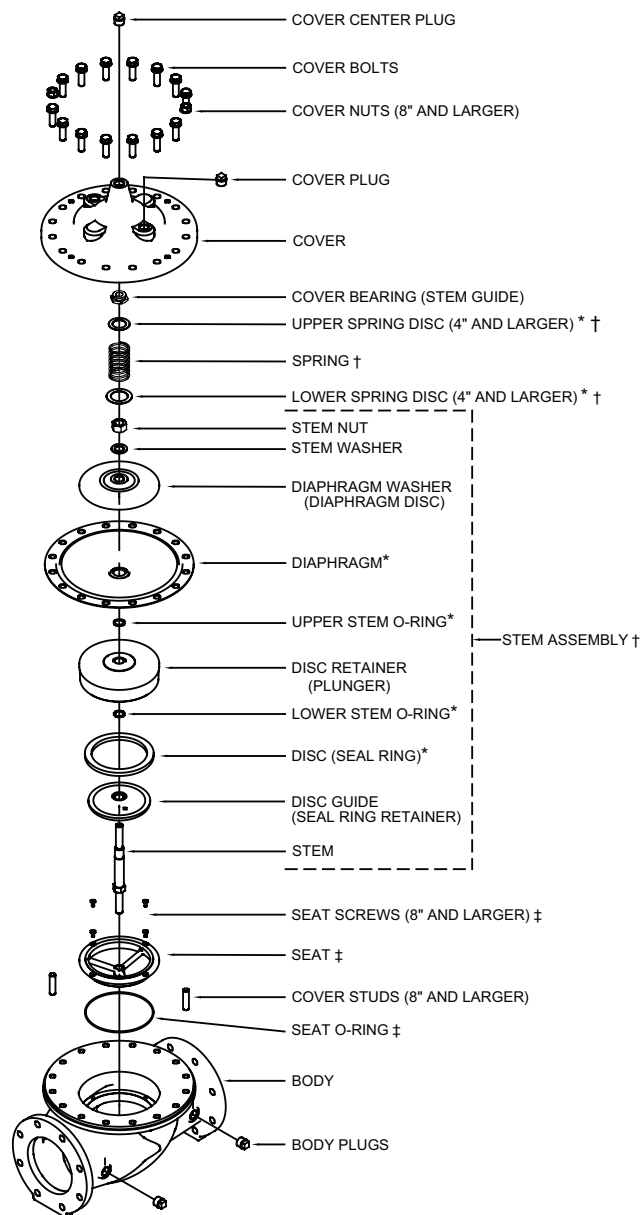

* RUBBER REPAIR KIT ITEMS
 † COMPLETE REPAIR KIT ITEMS
 ‡ SEAT REPAIR KIT

MAINTENANCE (PV-ACL-3 VALVE)

The 3-Way Accelerator Pilot may be installed in any position. The valve ports are labeled below.

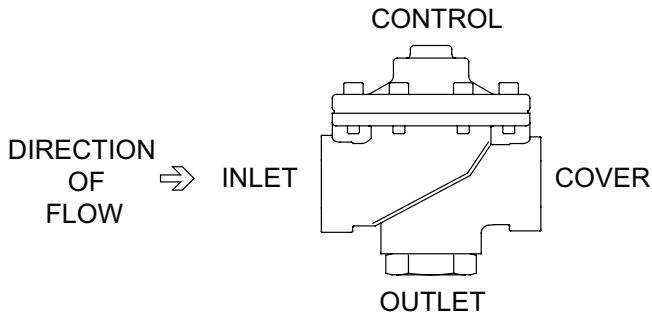

DISASSEMBLY

Prior to disassembly, relieve all pressure in pilot system and then remove the PV-ACL-3. Note the pilot connections and reinstall the pilot with the same connection placement when finished with maintenance.

1. Secure valve body and remove bottom seat on bottom of valve using an adjustable wrench.
2. Next remove 8 socket head screws around the pilot bell using a 5/32" hex key.
3. Remove the pilot bell and the spring.
4. Use a 5/32" hex key for the bottom plunger screw and a 12mm socket or adjustable wrench on the diaphragm nut to disassemble the plunger/diaphragm assembly. Unscrew one end of the stem.
5. At this point slide the plunger/diaphragm assembly out of the valve body.
6. Use soft jaws or a towel and pliers to clamp the stem. Remove the plunger, stem guide, screw, and small o-ring from the plunger assembly and 2 large washers, diaphragm, lock washer, o-ring and nut from the diaphragm assembly.
7. After complete disassembly, thoroughly clean and inspect all components before reassembly. Replace any parts as necessary after inspection.
8. The pilot seat generally does not need to be removed, but if after inspection it requires replacement it can be removed with a 1-1/16" socket.

PV-ACL-3 VALVE REASSEMBLY

Reassembly of the PV-ACL-3 is the reverse of disassembly.

1. Install one of the large washers (with round edge toward the diaphragm), the new o-ring, and the diaphragm followed by the second large washer (with round edge toward the diaphragm). Then place lock washer over stem threads along with the 5/16" diaphragm nut and tighten.
2. Next slide stem assembly into body through pilot seat.

3. Then slide the plunger onto the stem via the bottom seat hole followed by the small stem o-ring, stem guide and cap screw. While holding diaphragm nut, tighten the cap screw with Allen wrench.
4. Install bottom seat in bottom of valve body with new o-ring. The cross shaped stem guide must slide into the bottom seat.
5. Install spring and pilot bell on the valve body.
6. Insert socket head cap screws into pilot bell holes and thread into valve body. Tighten all screws in a cross pattern.
7. Reinstall into the pilot system once maintenance is completed. For further assistance or ordering replacement parts go to www.zurn.com or call product support 877-222-5356.

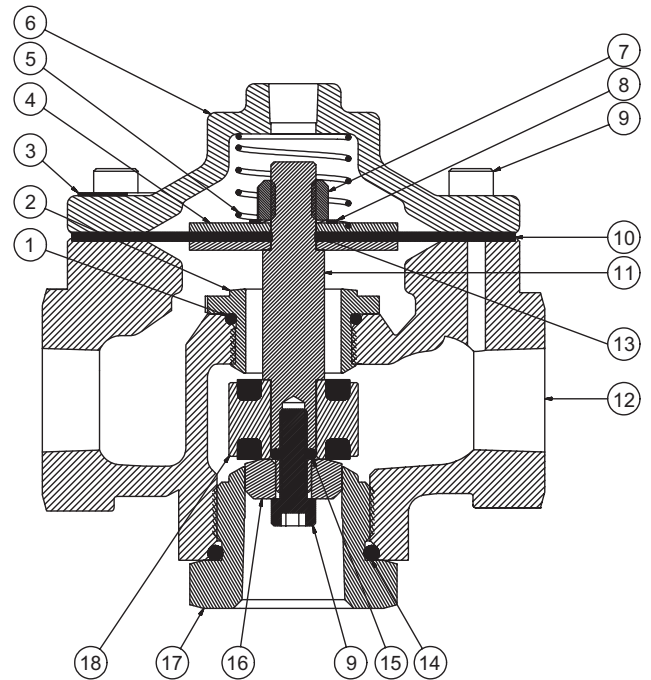

ITEM	DESCRIPTION	ITEM	DESCRIPTION
1	O-RING	10	DIAPHRAGM
2	PILOT SEAT	11	ACL STEM
3	TAG, ACCELERATOR PILOT	12	BODY
4	DIAPHRAGM WASHER	13	DIAPHRAGM O-RING
5	ACL STEM SPRING	14	O-RING, BUNA-N
6	ACL BELL	15	STEM O-RING
7	5/16-18 DIAPHRAGM NUT	16	STEM GUIDE
8	5/16" INT TEETH LOCKWASHER	17	ACL MAIN CAP/SEAT
9	10-32x5/8 SKT HEAD CAP SCREW	18	ACL PLUNGER ASSY.

PV-ACL-3 SPECS

Max Inlet Pressure: 400 psi

Flow Characteristics

BODY MINIMUM FRICTION LOSS

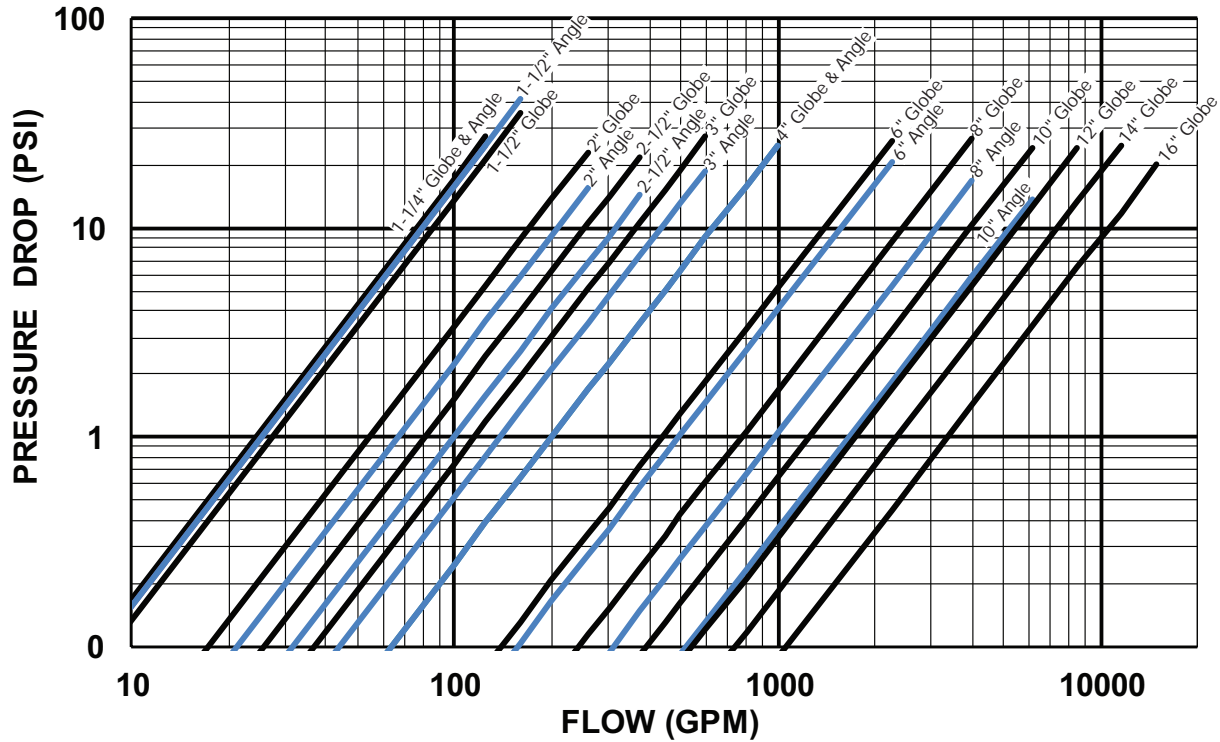

Note: If the valve is to be used for continuous flow, it is very important to maintain a flow rate through the valve below the maximum continuous flow rate. It may be necessary to install a gate or butterfly valve downstream to throttle the flow rate and prevent damage to the valve.

WARNING: This product contains a chemical known to the State of California to cause cancer, birth defects and other reproductive harm
ADVERTENCIA: Este producto contiene una sustancia química que el Estado de California como causante de cáncer, defectos de nacimiento y otros daños reproductivos