

## XP PLUS

The ENERGY STAR® Qualified A. O. Smith high efficiency condensing XP<sup>PLUS</sup> Water Heater utilizes a state-of-the-art heat exchanger and control technology to provide large volumes of hot water for demanding commercial and industrial potable hot water applications. The all stainless steel water tube heat exchanger construction allows the XP<sup>PLUS</sup> Water Heater to operate in a continuous condensing mode while maximizing longevity and delivering thermal efficiencies as high as 99% when operating in low temperature applications.

A unique multi-burner design is control sequenced and modulated to produce turndown rates of up to 20:1. Precise temperature control and accurate load matching produce smooth system operation and eliminates wasteful short cycling and temperature overshooting.

### ADVANCED MULTI-BURNER, LOW NO<sub>x</sub> COMBUSTION TECHNOLOGY

- Venturi-mixing gas/air ratio system - works with variable speed blower to precisely mix gas and air throughout the firing range.
- Fully modulating capability prevents energy-stealing short cycling and provides smooth system operation with higher overall system efficiencies.

### LOW NO<sub>x</sub> OPERATION

- Complies with SCAQMD Rule 1146.2 for XWH1000 through XWH2000 and Rule 1146.1 for XWH2600 and XWH3400, and other air quality management districts with similar requirements for low NO<sub>x</sub> emissions.

### ADVANCED SOLA CONTROL

- Large touch screen user interface.
- Factory standard with MODBUS protocol connections.
- The latest in energy saving algorithms.
- Includes remote tank temperature control to adjust tank temperature at the water heater – modulates the water heater to maintain tank set point temperature within +/-1 degree.
- Water heater output control features 20:1 turndown ratio on models 2 million btuh and up, 10:1 turndown ratio on models 1.7 million btuh and down.

### ALL-BRONZE FACTORY-MOUNTED PUMP(S)

- Integrally mounted, wired, and controlled by the water heater control.
- Factory-sized for proper flow between water heater and storage tank.
- Allows 50 equivalent feet of piping between water heater and tank.

### MULTI-PASS/MULTI-BURNER CONDENSING STAINLESS STEEL HEAT EXCHANGER

- Utilizes leading-edge multi-pass water tube heat exchanger to maximize heat transfer.
- Designed for fully condensing operation throughout the heating range.
- All heating surfaces are 316L stainless steel to provide a long and trouble-free service life.
- Saves both fuel and operating cost with every heating cycle.
- Impervious to thermal shock.

### DIRECT VENT FLEXIBILITY

- Direct vent up to 100 equivalent feet of pipe.
- Sidewall or vertical.
- Lower installation cost with approved CPVC/PVC venting material – uses CPVC for first 10 feet and PVC thereafter.
- Approved for use with UL approved AL29-4C® stainless steel venting materials.

### FACTORY START-UP INCLUDED

- Required for activating warranty and assuring maximum operating performance. Contact your local sales representative or Authorized Start-Up Agent to arrange a FREE certified start-up.

### MEETS THE THERMAL EFFICIENCY REQUIREMENTS OF THE U. S. DEPARTMENT OF ENERGY AND CURRENT EDITION ASHRAE/IES 90.1

### UP TO 96% THERMAL EFFICIENCY (AHRI CERTIFIED)

### 5-YEAR HEAT EXCHANGER WARRANTY

- For complete information, consult written warranty or contact A. O. Smith.



Please note: The XP<sup>PLUS</sup> water heater models XWH -1000 thru 3400 are certified to the ANSI Z21.10.3-CSA 4.3 water heater standard. These models are approved for potable water heating applications only and cannot be used in closed loop space/hydronic heating applications.



# Automatic Circulating Water Heaters

## OTHER XP<sup>PLUS</sup> FEATURES:

- CSA certified to the ANSI Z21.10.3-CSA 4.3 water heater standard
- Honeywell sola control with color touch screen LCD display
  - Inlet/outlet and remote tank temperature display
- Onboard Modbus communications
- Logs faults, run time, cycles
- Redundant flow and low water protection - factory installed LWCO and flow switch(s)
- Multi-burner sequencing models 2 million btuh and up have 4 burners; models 1.7 million btuh and down have 2 burners
- Redundant ignition controls – should one burner fail remaining burners continue to heat
- Alarm buzzer
- Remote tank temperature sensor included
- 20:1 turndown ratio on models 2 million btuh and up, 10:1 turndown ratio on models 1.7 million btuh and down
- Horizontal and vertical direct and sidewall vent options up to 100 equivalent feet of piping
- Approved for CPVC/PVC plastic vent materials

- Meets ASME CSD-1/GE gap codes – factory standard
- Direct spark ignition
- Factory-installed electrical disconnect
- All bronze factory-mounted pump(s)
- 316L stainless steel heat exchanger
- ASME 160# working pressure
- ASME rated pressure relief valve – 125 PSI

## XP<sup>PLUS</sup> OPTIONS:

- Condensate neutralization kit
- Vent termination kits
- Skid mounted systems



## Recovery Capacities

Recovery Capacities											
Model Number	BTU/HR Natural Gas Input	Water Flow	Temperature Rise								
			°F	40	60	70	80	90	100	120	140
			°C	22	33	39	44	50	56	67	78
XWH-1000	920,000	GPH		2,662	1,775	1,521	1,331	1,183	1,065	887	761
		LPH		10,078	6,719	5,759	5,039	4,479	4,031	3,359	2,880
XWH-1300	1,300,000	GPH		3,742	2,495	2,139	1,871	1,663	1,497	1,247	1,069
		LPH		14,167	9,444	8,095	7,083	6,296	5,667	4,722	4,048
XWH-1700	1,700,000	GPH		4,904	3,269	2,802	2,452	2,180	1,962	1,635	1,401
		LPH		18,565	12,376	10,608	9,282	8,251	7,426	6,188	5,304
XWH-2000	2,000,000	GPH		5,794	3,862	3,311	2,897	2,575	2,317	1,931	1,655
		LPH		21,931	14,621	12,532	10,966	9,747	8,773	7,310	6,266
XWH-2600	2,600,000	GPH		7,501	5,000	4,286	3,750	3,334	3,000	2,500	2,143
		LPH		28,393	18,929	16,225	14,196	12,619	11,357	9,464	8,112
XWH-3400	3,400,000	GPH		9,891	6,594	5,652	4,945	4,396	3,956	3,297	2,826
		LPH		37,441	24,961	21,395	18,721	16,641	14,976	12,480	10,697

## SINGLE HEAT EXCHANGER MODELS Rough In Dimensions (Single)

Models	XWH-1000		XWH-1300		XWH-1700	
Dimensions	Inches	mm	Inches	mm	Inches	mm
Flue Outlet Diameter	6	152	8	152	8	203
Air Intake Diameter	6	152	6	152	8	203
Wat Inlet	2 inch NPT				2-1/2 inch NPT	
Water Outlet	2 inch NPT				2-1/2 inch NPT	
Gas Inlet	2 inch NPT				2 inch NPT	
A	47	1199	49	1245	57	1448
B	67	1702	68	1727	76	1930
C	29	737	29	737	29	737
D	37	940	38	965	37	940
E	23	584	23	584	24	610
F	9	29	9	229	9	229
G	34	864	34	864	34	864
H	44	1118	45	1143	45	1143
J	6	152	6	152	6	152
K	11	279	11	279	11	279
L	12	305	11	279	12	305

Dimensions and specifications subject to change without notice in accordance with our policy of continuous product improvement.

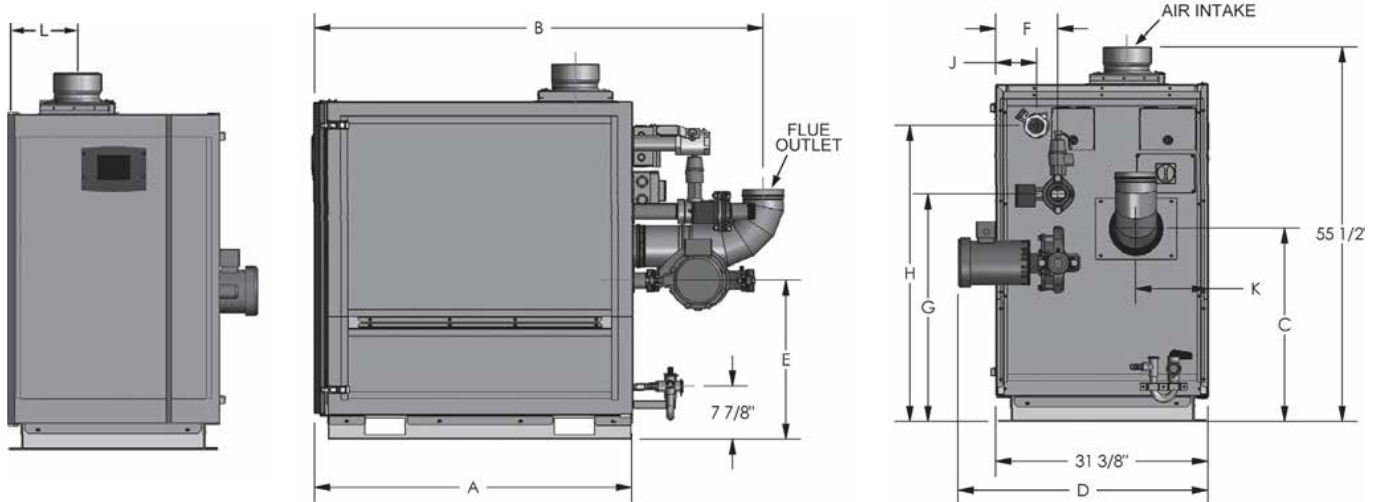

## DOUBLE HEAT EXCHANGER MODELS Rough In Dimensions (Double)

Models	XWH-2000		XWH-2600		XWH-3400	
Dimensions	Inches	mm	Inches	mm	Inches	mm
Flue Outlet Diameter	8	203	8	203	10	254
Air Intake Diameter	8	203	8	203	10	254
Wat Inlet	3 inch NPT				4 inch NPT	
Water Outlet	3 inch NPT				4 inch NPT	
Gas Inlet	2 inch NPT				3 inch NPT	
A	47	1199	49	1245	57	1448
B	78	1981	80	2032	91	2311
C	36	914	37	940	37	940
D	22	559	22	559	22	559
E	40	1016	41	1041	41	1041
F	7	178	6	152	6	152
G	10	254	10	254	10	254
H	4	102	4	102	4	102
J	20	508	19	483	19	483
K	12	305	12	305	13	330

Dimensions and specifications subject to change without notice in accordance with our policy of continuous product improvement.

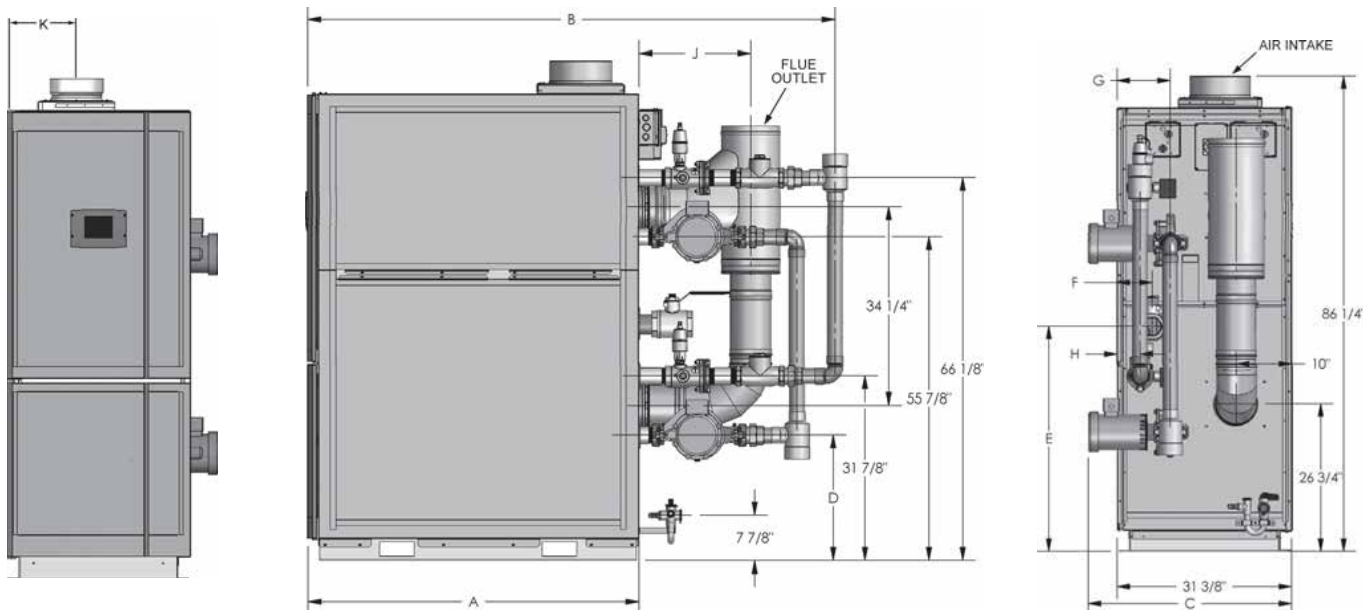

## VERSATILE MULTI-VENTING CONFIGURATIONS

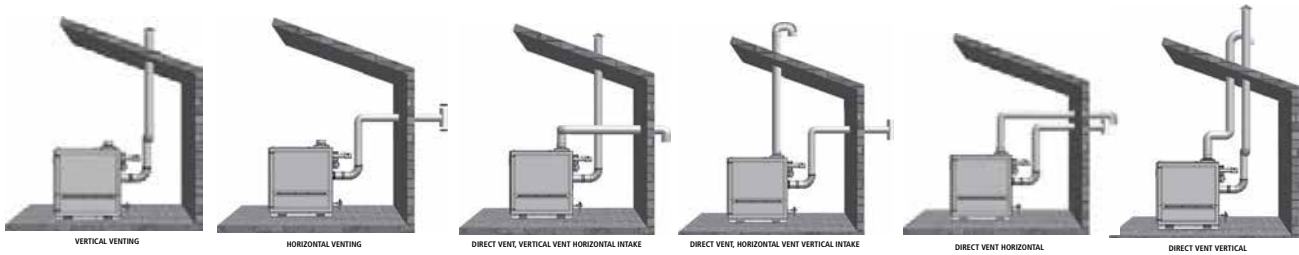

Direct or sidewall vent for up to 100 equivalent feet of pipe. Lower installation cost with approved CPVC/PVC venting material – uses CPVC for first 10 feet and PVC thereafter. Also approved for use with UL approved AL 29-4C stainless steel venting materials. For the detailed venting instructions review the XP<sup>PLUS</sup> water heater instruction manual at [www.hotwater.com](http://www.hotwater.com).

## APPROVED VENT AND AIR INTAKE FITTINGS

EXHAUST/VENT TERMINATIONS (PVC) PART #S			
Models	Pipe Size	Vertical (PVC Rain Cap)	Horizontal (PVC Tee w/ Screens)
XWH 1000	6"	320884-000	321765-000
XWH 1300	8"	320884-001	321765-001
XWH 1700			
XWH 2000			
XWH 2600			
XWH 3400	10"	320884-002	321765-002

AIR INTAKE TERMINATION (PVC) PART #S		
Models	Pipe Size	Combustion Air Intake (Elbow)
XWH 1000	6"	321764-000
XWH 1300	8"	321764-001
XWH 1700		
XWH 2000		
XWH 2600		
XWH 3400	10"	321764-002

Please note: When direct or sidewall venting, the water heater's CSA certification requires that only the above approved vent and combustion air intake terminations be used.

## FLOW RATE

RECOMMENDED FLOW RATES @ 0-12 GRAINS PER GALLON			
Models	Temperature Rise (ΔT °F)	GPM	Pressure Loss In Feet of Head (P)
XWH 1000	25	70	17.5
XWH 1300	25	99	22
XWH 1700	25	129	23
XWH 2000	25	153	17.5
XWH 2600	25	198	22
XWH 3400	25	261	23

Notes: For hard water systems with water hardness greater than 12 grains per gallon, A. O. Smith recommends a water softener be installed and maintained. The factory installed/supplied pump is sized to maintain a ΔT of 25°F through the water heater at 100% fire. In addition to the pressure loss through the water heater, the factory supplied pump is sized for an additional 50 feet of equivalent feet of piping between the water heater and a storage tank. Consult the factory for systems where the piping between the water heater and the tank exceed 50 equivalent feet.

## GAS PRESSURE REQUIREMENTS

Model Number	Type of Gas	Maximum Supply Pressure		Minimum Supply Pressure	
		Inches W.C.	kPa	Inches W.C.	kPa
1000, 1300, 1700, 2000, 2500, 34000	Natural	14	3.49	4	1
	Propane	14	3.49	4	2

## ELECTRICAL REQUIREMENTS

Model Number	Supply Voltage (Volts)	Frequency (Hz)	Current (Amps)
XWH-1000	120V	60	30
XWH-1300	120V	60	30
XWH-1700	120V	60	30
XWH-2000	120V	60	60
XWH-2600	120V	60	60
XWH-3400	120V	60	60



# Automatic Circulating Water Heaters

## XWH SUGGESTED SPECIFICATION

The gas-fired automatic circulating water heater(s) shall be A. O. Smith XP<sup>PLUS</sup> model XWH \_\_\_\_\_ having an input rating of \_\_\_\_\_ BTU/hr and capable of supplying no less than \_\_\_\_\_ GPH at a 100°F temperature rise when fired with (Natural/Propane) gas. 1) The water heater shall be capable of full modulation with a turndown ratio of \_\_\_\_\_:1 (use 10:1 WH models 1000 thru 1700, use 20:1 WH models 2000 thru 3400). 2) The water heater shall bear the ASME "HLW" stamp and shall be National Board registered (CRN in Canada) for 160 PSI working pressure. 3) The water heater(s) shall be equipped with a factory-installed 125# PSIG ASME Pressure Relief Valve. 4) The water heater(s) shall be design-tested and certified to the ANSI Z21.10.3-CSA 4.3 Standards by CSA International. 5) The water heater shall operate up to 96% thermal efficiency at full fire as certified with AHRI. 6) The water heater shall be certified for indoor installation and approved for installation on combustible floors.

The heat exchanger: 1) Shall be a dual burner multi-pass design with three sets of helical wound 316L stainless steel water tubes that completely encircle dual combustion chambers for maximum efficiency. 2) There shall be no bolts, gaskets or "O" rings in the header configuration. 3) The heat exchanger shall be removable and replaceable as a single component 3) The fully condensing heat exchanger shall be designed to allow all condensate to be drained from the bottom of the heat exchanger to ensure that condensation does not collect or interfere with good water heater operation due to long periods of operation in the condensing mode. 4) The low water volume heat exchanger shall be immune to thermal shock. 5) The entire heat exchanger shall carry a five (5) year warranty.

Water Heater Pump: 1) The automatic circulating water heater(s) shall be supplied with a factory-sized and wired all bronze circulating pump(s). 2) The pump(s) shall be interfaced with and managed by the water heater's control and cycled as needed for most efficient operation.

Burners: 1) The water heater shall have (two/four) modulating burners capable of modulating between 20% and 100% fire while providing smooth starts and clean combustion. 2) Each burner shall be a premix design, constructed of high temperature stainless steel and utilize a woven metal fiber mesh covering, be warranted for 5 years, and fire in a radial 360-degree flame pattern. 3) Burner ignition shall be by direct spark with flame monitoring via a flame sensor.

Water Heater Controls: 1) The water heater shall feature the Sola control with a multi-colored LCD touch screen display. 2) The control shall provide intuitive user operation and setup of the water heater. 3) The control will cascade/sequence, rotate and modulate the water heater's multiple burners providing an overall turndown rate of (20/10):1. 4) The control shall display current inlet, outlet, and tank temperatures along with current firing rate for each burner. 5) Data logging with run time/number of cycles and all faults shall be recorded. 6) The water heater shall be BMS ready with factory standard with onboard MODBUS protocol connections. 7) A remote tank temperature sensor shall be shipped loose with the unit to be installed in the storage tanks and allow remote tank temperature control and monitoring at the water heater. 8) The tank temperature set point and set point differential shall be adjustable and shall be maintained within +/-1 degree. 9) Night temperature setback shall be standard. 10) Redundant flow and low water protection shall be provided with factory installed and wired LWCO and flow switch(s). 11) Redundant ignition controls (one per burner) shall allow individual burner operation. 11) Factory installed Alarm Buzzer will be provided along with dry contacts for remote alarm if desired.

Frame and Jacket Design: 1) Shall be constructed of a rugged all welded extruded aluminum alloy frame with heavy gauge steel removable jacket panels that allow easy access and service. 2) The jacket panels shall be painted on both sides with a high quality powder coating that is approved for outdoor use. 3) Primary/main service access shall be provided by a latched and hinged stainless steel access door(s) that provides access to most electrical and serviceable components from the front of the unit.

Venting: 1) The water heater shall be certified for direct horizontal through-the-wall venting or direct vertical venting; in addition to sidewall or conventional vertical venting. 2) The water heater shall be capable of horizontal sidewall or direct venting up to 100 equivalent feet without the aid of any optional sidewall vent fans or blowers. 3) The water heater shall be CSA approved for venting with CPVC or a combination of CPVC and PVC venting materials using CPVC for first 10 feet and PVC thereafter. In addition the water heater shall be approved for use with UL approved AL29-4C stainless steel venting materials where local codes may require.

Standards: 1)The water heater shall have an independent laboratory rating for Oxides of Nitrogen (NOx) to meet the requirements of South Coast Air Quality Management District in Southern California and the requirements of Texas Commission on Environmental Quality. 2) The water heater shall built to and meet the ASME – CSD-1 code requirements as factory standard. 3) The water heater shall be compliant with California Code, Factory Mutual, Massachusetts Code and Kentucky Codes and standards.

Factory Start-Up: 1) The water heater manufacturer shall furnish, at no additional charge, the complete certified factory start-up that is required for activating the warranty and ensuring