

INSTALLATION GUIDE

Soap Dispenser - SD6000, SD7000



INSTALLATION INSTRUCTIONS

- 1 Remove all contents from the package and check for completeness.

NOTE:

Call immediately if you see inconsistencies.

(1-800-626-5771)

or visit

www.frankeksd.com

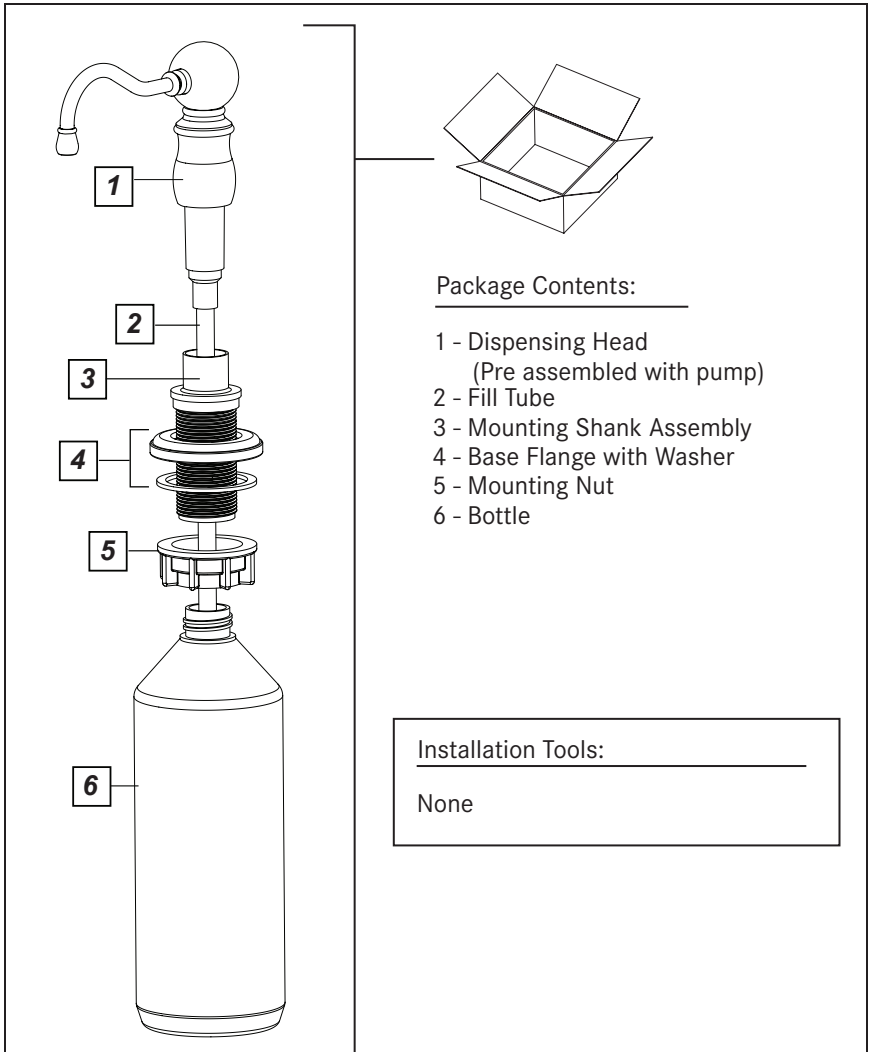

Installation

- 2 Ensure proper hole is in place for the Dispenser. This Dispenser is designed to mount into a 1-3/8" (35mm) mounting hole.
- 3 Product will arrive with dispensing head already mounted in base flange. Remove the dispensing head assembly from the base flange assembly. Insert the fill tube into the pump at the bottom of the dispensing head assembly and set this aside.
- 4 Unscrew the mounting nut from the base flange assembly. Insert the base flange into the mounting hole. Be sure the mounting washer is in place between the flange and mounting surface.
- 5 From underneath the mounting surface, install the mounting nut onto the base flange firmly by hand and install the bottle into the base flange hand tight.

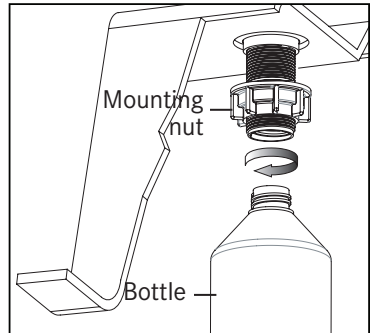
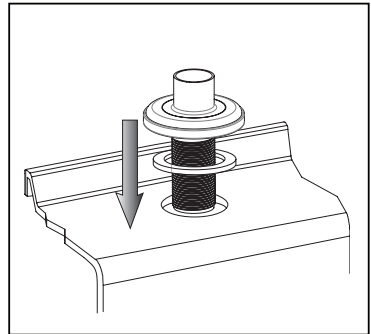
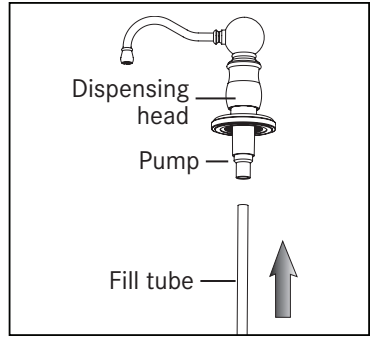

- 6 Fill bottle with soap or lotion.

Note: For Most efficient use with soaps, it is recommended to fill the bottle 1/3 with water and 2/3 with soap and mix well using the fill tube to minimize clogging.

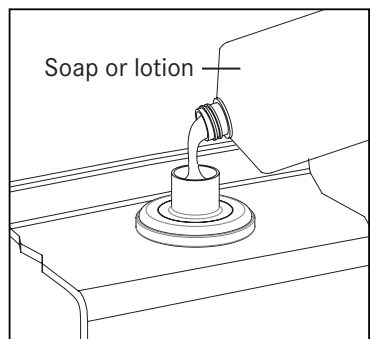

Installation

- 7 Insert the dispensing head assembly with assembled fill tube into the base flange and bottle and point the discharge of the dispensing head towards the front of the sink, or to the desired location.

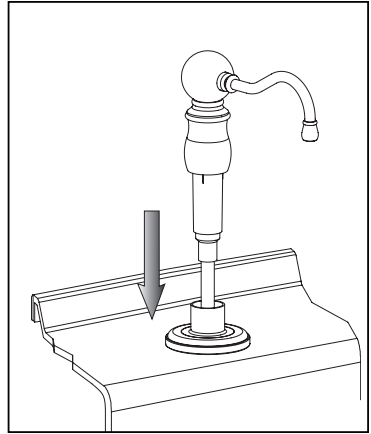

- 8 Pump dispensing head several times until soap/lotion is discharged through the head.

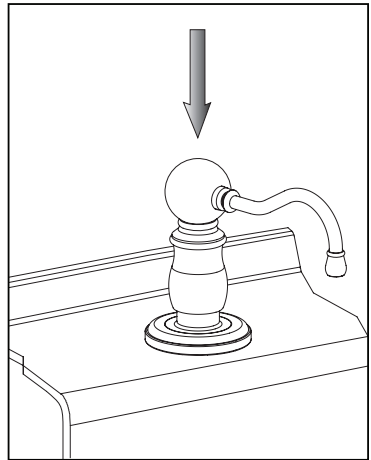

Usage

- 1 With the bottle full, press the Dispensing Head to discharge soap/ lotion. Remove pressure from the Dispensing Head, and it will return to the original position, and it can be pumped again.

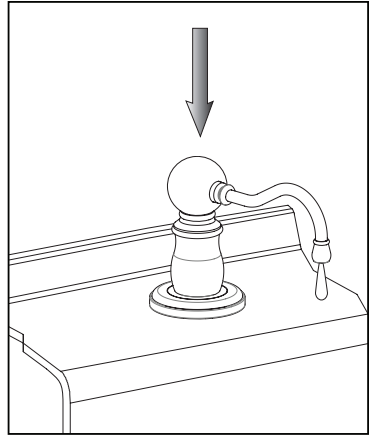

- 2 Continue pumping until desired amount of soap/ lotion is discharged.

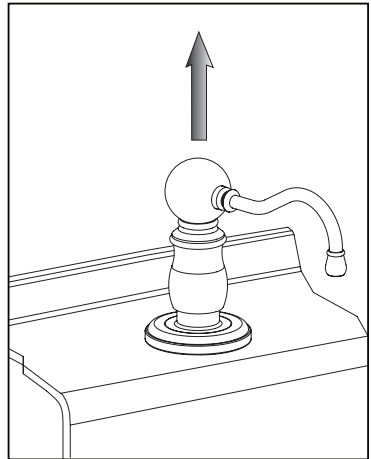

MAINTENANCE

- 1 With normal use, maintenance should not be necessary. Should there be an extended period where the dispenser is not used, it is possible the soap/lotion could harden and prevent proper discharge. In this event, submerge the entire Dispensing Head with Pump into hot water for several minutes. Next pump hot water through the assembly. Repeat as necessary to remove the obstruction.
- 2 To clean the dispenser, use a soft cloth or sponge with soap and water only. Do not use any abrasive cleaners or pads. Dry with a cloth or paper towel.

3 Replacement Parts

- 1 - SD2401 Pump
- 2 - SD2402 Bottle
- 3 - SD2403 Fill Tube

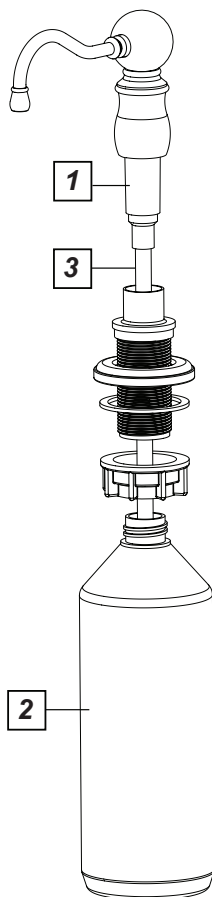

PRODUCT WARRANTY

Congratulations on the purchase of this Franke product! Franke is one of the world's largest manufacturers of kitchen systems. Our products are manufactured using the highest degree of technology, quality, and design. As a result, we are proud to offer the following warranty.

Franke warrants the quality of its soap/lotion dispensers to be free from manufacturing defects for a period of **five** years from the date of purchase. This warranty applies only to the original owner, providing the product has been installed in accordance with these installation instructions, used as recommended, and in normal residential application. **In the event of a warranty claim, the owner will be required to provide proof of purchase - SAVE ORIGINAL SALES RECEIPT!** This warranty covers all components which make the product operational. Franke reserves the right to inspect the installation prior to the replacement of the product or component part.

This warranty does not cover misuse or abuse, accidental damage, scuffs, or scratches, abnormal usage, negligence or damage caused by improper maintenance or cleaning. Normal wear of parts is excluded from the warranty. Damage caused by impurities or acts beyond Franke's control are not covered. Any product or part which has been repaired or altered in any manner outside of Franke's factory, unless previously authorized in writing by Franke, will void the warranty. **Any replacement excludes transportation and any labor reinstallation costs.** This warranty doesn't allow recovery of incidental or consequential damages such as loss of use, delay, property damage, or other consequential damage, and Franke accepts no liability for such damages.

The Franke warranty is limited to the above conditions and to the warranty period specified herein and is exclusive. Franke **DISCLAIMS** all other warranties, expressed or implied, including the **IMPLIED WARRANTIES OF MERCHANTABILITY AND/OR FITNESS FOR A PARTICULAR PURPOSE.** This warranty gives you specific legal rights which may vary from state to state.

Further Information

For any further information about Franke products, about the installation of them, or about the guarantee, please contact our Customer Service Department:

Franke Consumer Products Inc.,
Kitchen Systems Division
800 Aviation Parkway
Smyrna, TN 37167
Phone: 1-800-626-5771
Fax: 1-888-685-0007
www.frankeksd.com



Franke Consumer Products Inc.,
Kitchen Systems Division
800 Aviation Parkway
Smyrna, TN 37167
Phone: 1-800-626-5771
Fax: 1-888-685-0007
www.frankeksd.com