

8 7 6 5 4 3 2 1

ECN	REV	ZONE	DESCRIPTION	CHK	D	DATE
XXXXXX	A	XXXX		-	GL	

E  
D  
C  
B  
A

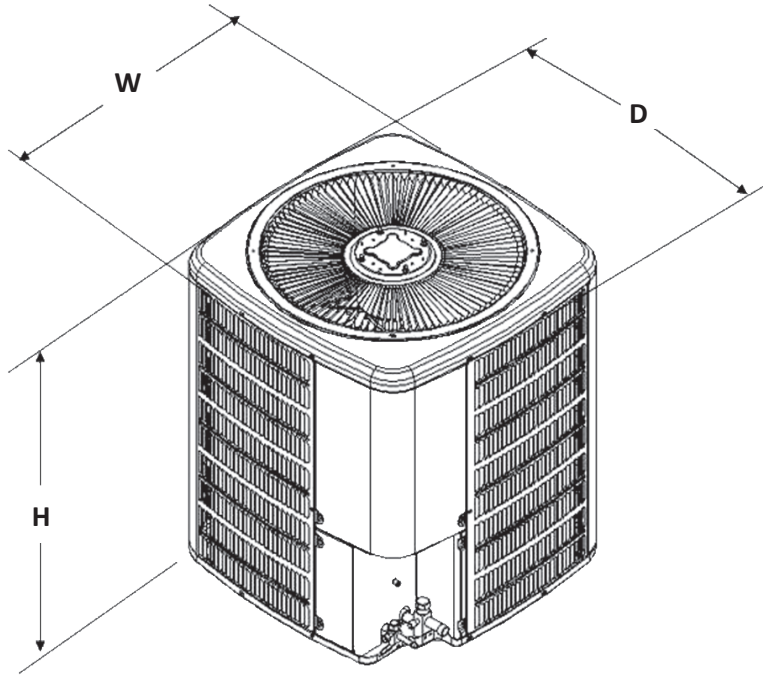

MODEL	DIMENSIONS		
	W"	D"	H"
GSZ140181/191**	29	29	34½
GSZ140241/251**	29	29	34½
GSZ140301**	29	29	36¼
GSZ140311A*	35½	35½	34¼
GSZ140361**	29	29	36¼
GSZ140371A*	35½	35½	40
GSZ140421**	35½	35½	39¼
GSZ140481**	29	29	36¼
GSZ140491**	35½	35½	34¼
GSZ140601**	35½	35½	34¼

E  
D  
C  
B  
A

**SPECIAL CHARACTERISTICS:**

- 6SIGMA
- CRITICAL CHARACTERISTIC
- SIGNIFICANT CHARACTERISTIC

COMPONENTS AND MATERIALS SPECIFIED HEREIN WILL ALSO CONFORM TO THE APPLICABLE SECTION OF GOODMAN MSP 824 01 WORKMANSHIP STANDARD FOR FIT, FEEL AND FINISH.

CONFIDENTIAL PROPERTY OF THE GOODMAN MANUFACTURING COMPANY, L.P. NOT TO BE DISCLOSED TO OTHERS, COPIED, OR USED FOR ANY PURPOSE EXCEPT AS AUTHORIZED IN WRITING. MUST BE RETURNED UPON DEMAND, ON COMPLETION OF ORDER, OR OTHER PURPOSE FOR WHICH IT WAS LENT.

**Goodman Manufacturing Co., L.P.**

**GSZ14**

DRAWING TO BE INTERPRETED IN ACCORDANCE WITH ASME Y14.100. DIMENSIONS ARE IN INCHES UNLESS OTHERWISE NOTED.

TOLERANCES:  
 ANGLES ± 1.5°  
 X ± .1  
 .XXX ± .015  
 HOLE Ø ± .005  
 TUBE CUT L.G. ± .063

DWN BY:	ENG:	<b>DO NOT SCALE DRAWING</b>
		SHT 1 OF 1

REV  
**A**

8 7 6 5 4 3 2 1