

INSTALLATION OF ARD AND EARD DAMPERS

Before Installing this Product...

1. Read all instructions before installing this product. Failure to follow the instructions can damage the product or cause a hazardous condition.
2. Check the ratings given in the instructions and on the product to make sure the product is suitable for your application.
3. Installer must be a trained, experienced service technician.
4. Install the product in an area that is easily accessible for checkout and service.
5. After completing installation, use these instructions to check out the product operation.

Installing the Round (ARD and EARD) Dampers

1. Insert the crimped end of the ARD or EARD into the uncrimped end of the rigid round duct and secure with sheet metal screws (not provided). When using flexible duct, slip the duct over the end of the ARD or EARD and secure it with duct straps (not provided).
2. When installing the damper in a horizontal application, make sure the motor actuator is located on the side or top of the damper. Do not locate the motor on the bottom of the damper. The damper can be mounted in a vertical duct.
3. Adjust Range stop position to desired closed positions. ARD and ZD Dampers are completely closed in position 0. EARD Dampers are completely open in position 0.

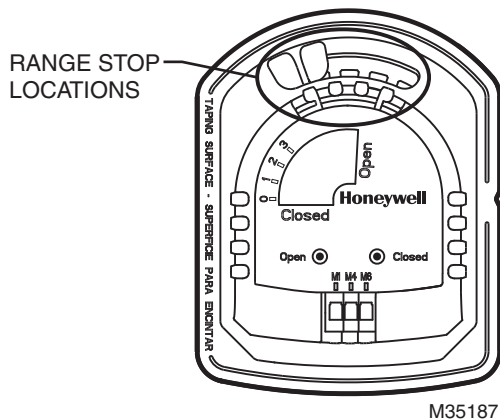

Fig. 2. TrueZONE Actuator range stop positions.

Wiring Multiple Dampers

When the same zone controls two or more dampers, wire the dampers in parallel to terminals M1 and M6 on the zone control panel.

INSTALLATION OF ZD DAMPER

When Installing this Product...

1. Read these instructions carefully. Failure to follow these instructions can damage the product or cause a hazardous condition.
2. Check the ratings given in the instructions and on the product to make sure the product is suitable for your application.
3. Installer must be a trained, experienced service technician.
4. All wiring must comply with local electrical codes, ordinances, and regulations.
5. After completing installation, use these instructions to check out the product operation.

Planning the Installation

Selecting a Location

Select a location for the zone dampers that is at least three feet from the HVAC unit plenum in the air duct takeoff to the respective zone and is easily accessible for checkout and maintenance.

The ZD comes complete and ready for installation. The motor and linkage are factory-assembled to the damper. The damper is assembled for installation and wiring to the control panel.

Selecting Damper Size

To ensure correct operation, be sure to select the correct zone damper size for the air duct:

IMPORTANT

Be aware that damper sizes are built 5/32 in. smaller than the listed dimensional sizes.

- If the damper is forced into an undersized air duct, the excess pressure can jam the damper blades and cause improper operation.
- When a small percentage of continuous flow is desired in a zone, even when the damper blades are closed, adjust motor closed position to be slightly open to maintain desired air flow.

Selecting Location with Humidifier Installed

IMPORTANT

Excessive lime or mineral deposits can accumulate on damper blades and cause improper operation when spray or atomizing type humidifiers are installed in the furnace plenum or air supply duct with the zone dampers.

- Spray or atomizer type humidifiers that are installed in the furnace plenum or air supply duct are not recommended.
- Evaporative type humidifiers are recommended.

Installing the Damper

IMPORTANT

- Install dampers into a squared air duct.
- Do not weld dampers to the air ducts.
- Do not force dampers into undersized air ducts. Excess pressure can damage damper blades.
- Be sure high limit setting is less than 200° F (93°C).
- Higher settings can damage the electric actuator.

1. Be sure the ZD is correctly sized to the air duct (see Selecting Damper Size section).
2. Select a ZD location that is three feet from the furnace plenum.
3. Cut a 4-in. (102 mm) opening in the accessible side of the air duct at the location selected; ensure the opening of the air duct is cut fully from seam to seam.
4. Secure the ZD mounting plate to the air duct with the self-tapping sheet metal screws provided.

WIRING

CAUTION

Personal Electrical Shock Hazard. Can cause electrical shock or equipment damage.
Disconnect power before beginning installation.

The damper motor has a 24 Vac, 50/60 cycle, 8 VA rating. The spring-return ARD and ZD damper requires 24 Vac to the two motor leads to power the damper closed. The damper then returns to its normal open position once power is removed. EARD damper requires 24 Vac to the two motor leads to power the damper open. The damper then returns to its normal closed position once power is removed.

NOTE: Multiple dampers can be wired in parallel.

Wiring a Motor

See Fig. 3 and 7 for motor wiring hookups for ARD and ZD Dampers

Changing Motor on ARD, EARD and ZD Dampers

1. Disconnect the motor wiring.
2. Loosen the socket head cap set screw located between the faceplate and the motor coupling.
3. Remove the motor.
4. Ensure damper blade is in the open position with the set screw pointing toward the open position on the label.
5. Attach new motor to the coupling; be sure the standoff on motor is positioned in the grommet on the faceplate and the set screw is aligned with the motor shaft hole.
6. Tighten the set screw.

Wiring a Single ARD (Power Closed) to a Control Panel

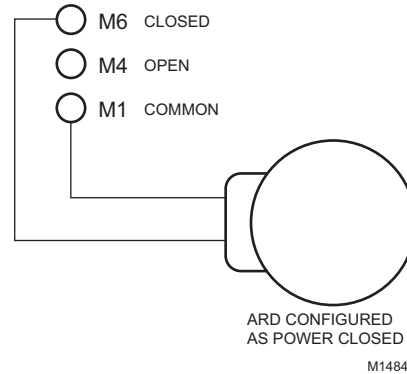

Fig. 3. ARD configured as power closed.

Checkout

CAUTION

Possible Equipment Damage

Do not manually open or close the damper as this can damage the actuator.

To check out the ARD:

1. With 24 Vac applied to the motor leads, observe the motor powering the damper to the closed position.
2. When energized, verify that the actuator connection coupling rotates in a clockwise direction (as viewed from the operator base end) and that the damper shaft turns with the coupling.
3. With power removed, observe the damper returning to the normally-open position.

NOTE: To remove power, disconnect one wire from the motor.

4. If the motor does not operate smoothly and without hesitation throughout the complete opening and closing stroke, examine the damper and the shaft for free rotation within the duct.

Wiring an EARD to a W8150

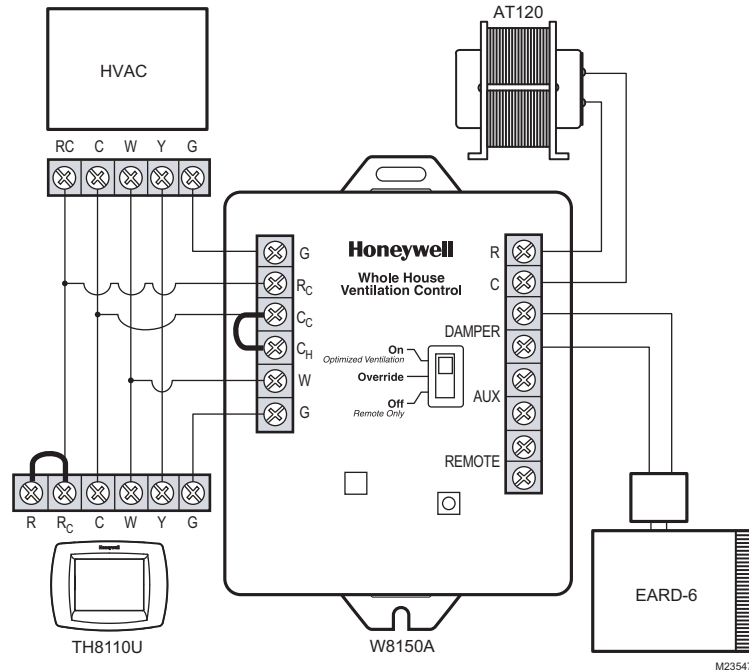

Fig. 4. EARD and W8150 wiring.

Wiring an EARD to a VisionPRO® IAQ Thermostat

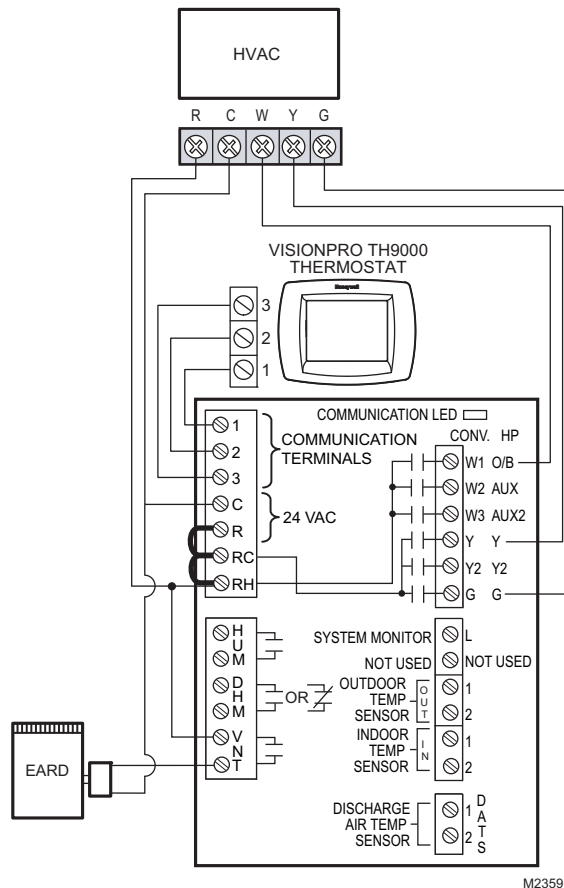

Fig. 5. EARD and VisionPRO® IAQ thermostat wiring.

TRUEZONE ARD, EARD, AND ZD SERIES DAMPERS

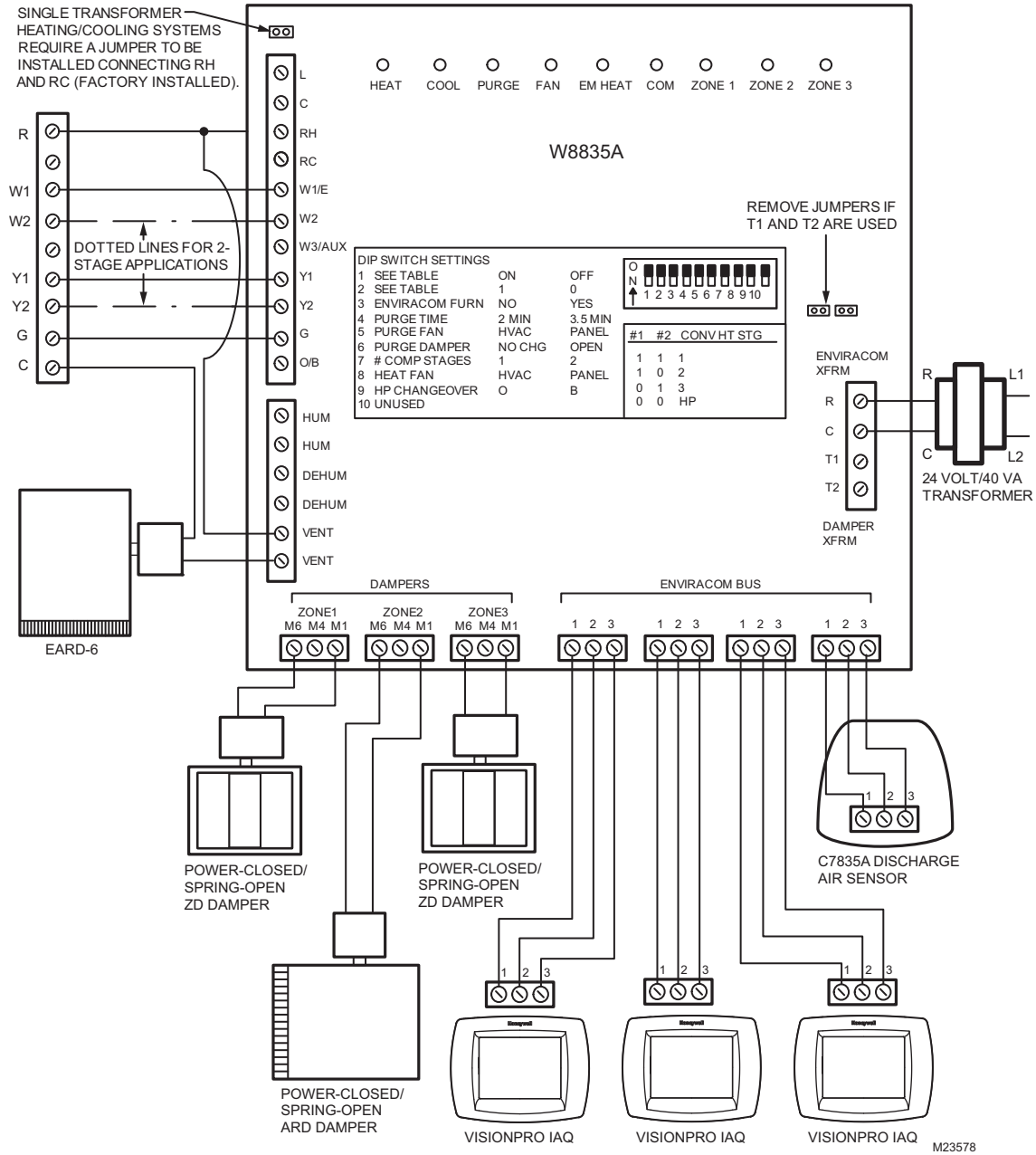

Fig. 6. EARD with W8835 EnviraZone panel.

CHECKOUT

To check out the EARD:

1. With 24 Vac applied to the motor leads, observe the motor powering the damper to the open position.
2. When energized, verify that the actuator connection coupling rotates in a clockwise direction (as viewed from the operator base end) and that the damper shaft turns with the coupling.
3. With power removed, observe the damper returning to the normally-closed position.

NOTE: To remove power, disconnect one wire from the motor.

4. If the motor does not operate smoothly and without hesitation throughout the complete opening and closing stroke, examine the damper and the shaft for free rotation within the duct.

ZD Damper WIRING



CAUTION

Personal Electrical Shock Hazard.

Can cause electrical shock or equipment damage.
Disconnect power before beginning installation.

The ZD has a 24 Vac, 50/60 cycle, .32A motor. The ZD is wired to terminals M1 and M6 for power closed/spring return open, with an option for M4 wire to power LED light only. The ZD is a spring return damper that requires 24V to the two motor leads to power the damper closed. When power is removed from the motor, the damper springs back to its normally-open position. When used with Honeywell Networked Zoning, use closed and com terminals.

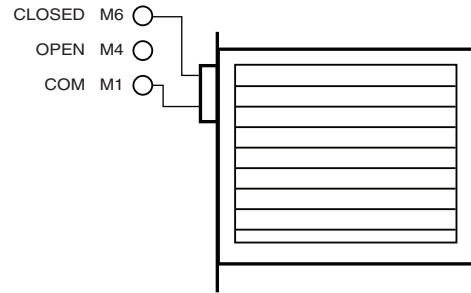

NOTE:
WHEN INSTALLING ON OLDER MASTERTROL™
BOARDS SUCH AS THE MARK V, JUMPER
M2-M5 ON THE PANEL.
M14851A

Fig. 7. Power closed spring return open ZD wiring.

Wiring Multiple Dampers

When the same zone controls two or more dampers, wire the dampers in parallel to terminals M1 and M6 on the zone control panel.

Wiring a Motor

See Fig. 7 for typical motor wiring hookup.

CHECKOUT

To check out the ZD:

1. With 24 Vac applied to the motor leads, observe the motor powering the damper to the closed position.
2. When energized, verify that the actuator connection coupling rotates in a clockwise direction (as viewed from the operator base end) and that the damper shaft turns with the coupling.
3. With power removed, observe the damper returning to the normally-open position.

NOTE: To remove power, disconnect one wire from the motor.

4. If the motor does not operate smoothly and without hesitation throughout the complete opening and closing stroke, examine the damper and the shaft for free rotation within the duct.

Automation and Control Solutions

Honeywell International Inc.
1985 Douglas Drive North
Golden Valley, MN 55422
customer.honeywell.com

© U.S. Registered Trademark
© 2015 Honeywell International Inc.
33-00040—01 M.S. 02-15
Printed in United States

Honeywell