

RGS Series

3 to 10 Ton

With R-410A Refrigerant



3 to 6 Ton



7-1/2 to 10 Ton

TABLE OF CONTENTS

SAFETY CONSIDERATIONS 2	START-UP, GENERAL 39
UNIT ARRANGEMENT AND ACCESS 3	OPERATING SEQUENCES 40
SUPPLY FAN (BLOWER) SECTION 4	FASTENER TORQUE VALUES 41
COOLING 5	WIRING DIAGRAMS 42
R-410A REFRIGERANT 8	APPENDIX I. MODEL NUMBER SIGNIFICANCE . . 44
COOLING CHARGING CHARTS 9	APPENDIX II. PHYSICAL DATA 45
CONVENIENCE OUTLETS 14	APPENDIX III. FAN PERFORMANCE 49
SMOKE DETECTORS 14	APPENDIX IV. ELECTRICAL DATA 61
SENSOR AND CONTROLLER TESTS 16	APPENDIX V. WIRING DIAGRAM LIST 66
PROTECTIVE DEVICES 20	APPENDIX VI. MOTORMASTER SENSOR
GAS HEATING SYSTEM 20	LOCATIONS 67
ECONOMIZER SYSTEMS 30	UNIT START-UP CHECKLIST 69
PRE START-UP 38	

Service and Maintenance Instructions

SAFETY CONSIDERATIONS

Installation and servicing of air-conditioning equipment can be hazardous due to system pressure and electrical components. Only trained and qualified service personnel should install, repair, or service air-conditioning equipment. Untrained personnel can perform the basic maintenance functions of replacing filters. Trained service personnel should perform all other operations.

When working on air-conditioning equipment, observe precautions in the literature, tags and labels attached to the unit, and other safety precautions that may apply. Follow all safety codes. Wear safety glasses and work gloves. Use quenching cloth for unbrazing operations. Have fire extinguishers available for all brazing operations.

Follow all safety codes. Wear safety glasses and work gloves. Use quenching cloth for brazing operations. Have fire extinguisher available. Read these instructions thoroughly and follow all warnings or cautions attached to the unit. Consult local building codes and National Electrical Code (NEC) for special requirements.

Recognize safety information. This is the safety-alert symbol . When you see this symbol on the unit and in instructions or manuals, be alert to the potential for personal injury.

Understand the signal words DANGER, WARNING, and CAUTION. These words are used with the safety-alert symbol. DANGER identifies the most serious hazards which **will** result in severe personal injury or death. WARNING signifies a hazard which **could** result in personal injury or death. CAUTION is used to identify unsafe practices which **may** result in minor personal injury or product and property damage. NOTE is used to highlight suggestions which **will** result in enhanced installation, reliability, or operation.

WARNING

FIRE, EXPLOSION HAZARD

Failure to follow this warning could result in personal injury, death and/or property damage.

Refer to the User's Information Manual provided with this unit for more details.

Do not store or use gasoline or other flammable vapors and liquids in the vicinity of this or any other appliance.

What to do if you smell gas:

DO NOT try to light any appliance.

DO NOT touch any electrical switch, or use any phone in your building.

IMMEDIATELY call your gas supplier from a neighbor's phone. Follow the gas supplier's instructions.

If you cannot reach your gas supplier, call the fire department.

WARNING

ELECTRICAL OPERATION HAZARD

Failure to follow this warning could result in personal injury or death.

Before performing service or maintenance operations on unit, turn off main power switch to unit. Electrical shock and rotating equipment could cause injury.

WARNING

ELECTRICAL OPERATION HAZARD

Failure to follow this warning could result in personal injury or death.

Units with convenience outlet circuits may use multiple disconnects. Check convenience outlet for power status before opening unit for service. Locate its disconnect switch, if appropriate, and open it. Tag-out this switch, if necessary.

WARNING

UNIT OPERATION AND SAFETY HAZARD

Failure to follow this warning could cause personal injury, death and/or equipment damage.

R-410A refrigerant systems operate at higher pressures than standard R-22 systems. Do not use R-22 service equipment or components on R-410A refrigerant equipment.

WARNING

FIRE, EXPLOSION HAZARD

Failure to follow this warning could result in personal injury or death.

Disconnect gas piping from unit when pressure testing at pressure greater than 0.5 psig. Pressures greater than 0.5 psig will cause gas valve damage resulting in hazardous condition. If gas valve is subjected to pressure greater than 0.5 psig, it *must* be replaced before use. When pressure testing field-supplied gas piping at pressures of 0.5 psig or less, a unit connected to such piping must be isolated by closing the manual gas valve(s).

UNIT ARRANGEMENT AND ACCESS

General

Fig. 1 and Fig. 2 show general unit arrangement and access locations.

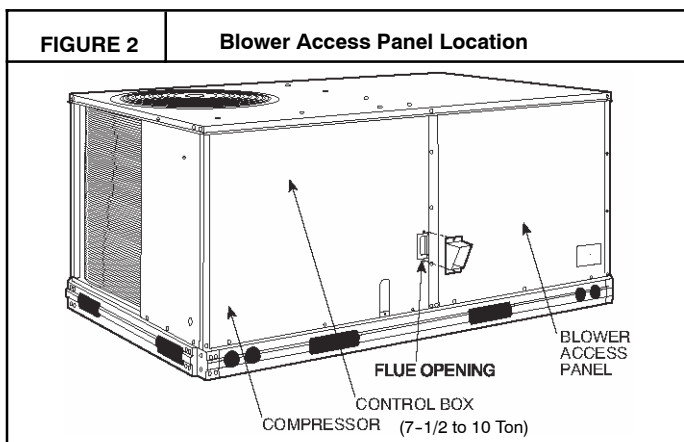
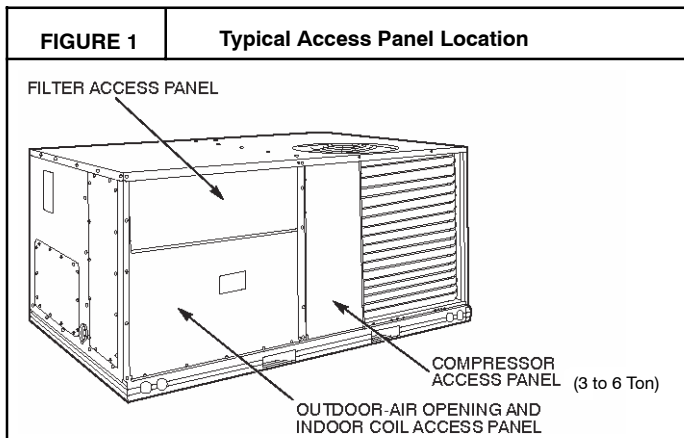

Routine Maintenance

These items should be part of a routine maintenance program, to be checked every month or two, until a specific schedule for each can be identified for this installation:

Quarterly Inspection (and 30 days after initial start)

- Return air filter replacement
- Outdoor hood inlet filters cleaned
- Belt tension checked
- Belt condition checked
- Pulley alignment checked
- Fan shaft bearing locking collar tightness checked
- Condenser coil cleanliness checked
- Condensate drain checked

Seasonal Maintenance

These items should be checked at the beginning of each season (or more often if local conditions and usage patterns dictate):

Air Conditioning

- Condenser fan motor mounting bolts tightness
- Compressor mounting bolts
- Condenser fan blade positioning

- Control box cleanliness and wiring condition
- Wire terminal tightness
- Refrigerant charge level
- Evaporator coil cleaning
- Evaporator blower motor amperage

Heating

- Heat exchanger flue passageways cleanliness
- Gas burner condition
- Gas manifold pressure
- Heating temperature rise

Economizer or Outside Air Damper

- Inlet filters condition
- Check damper travel (economizer)
- Check gear and dampers for debris and dirt

Air Filters and Screens

Each unit is equipped with return air filters. If the unit has an economizer, it will also have an outside air screen. If a manual outside air damper is added, an inlet air screen will also be present.

Each of these filters and screens will need to be periodically replaced or cleaned.

Return Air Filters

Return air filters are disposable fiberglass media type. Access to the filters is through the small lift-out panel located on the rear side of the unit, above the evaporator/return air access panel. (See Fig. 1.)

To remove the filters:

1. Grasp the bottom flange of the upper panel.
2. Lift up and swing the bottom out until the panel disengages and pulls out.
3. Reach inside and extract the filters from the filter rack.
4. Replace these filters as required with similar replacement filters of same size.

To re-install the access panel:

1. Slide the top of the panel up under the unit top panel.
2. Slide the bottom into the side channels.
3. Push the bottom flange down until it contacts the top of the lower panel (or economizer top).

IMPORTANT: DO NOT OPERATE THE UNIT WITHOUT THESE FILTERS!

Outside Air Hood (Optional)

Outside air hood inlet screens are permanent aluminum-mesh type filters. Check these for cleanliness. Remove the screens when cleaning is required. Clean by washing with hot low-pressure water and soft detergent and replace all screens before restarting the unit. Observe the flow direction arrows on the side of each filter frame.

Economizer Inlet Air Screen (Optional)

This air screen is retained by spring clips under the top edge of the hood. (See Fig. 3.)

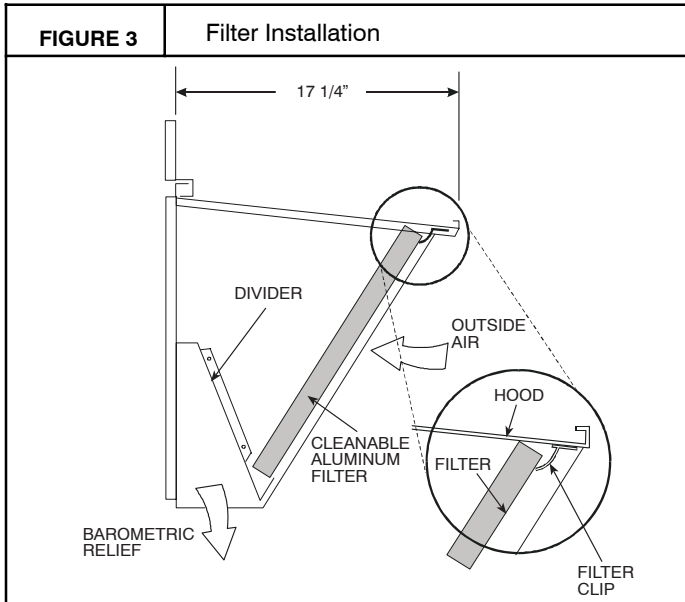

To remove the filter, open the spring clips. Re-install the filter by placing the frame in its track, then closing the spring clips.

Manual Outside Air Hood Screen (Optional)

This inlet screen is secured by a retainer angle across the top edge of the hood. (See Fig. 4.)

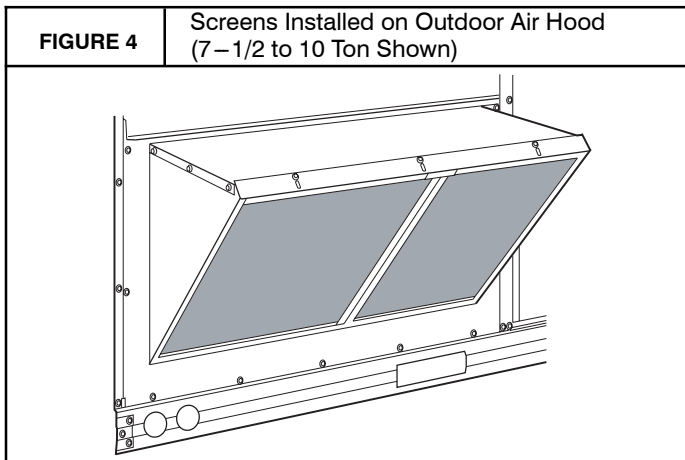

To remove the screen, loosen the screws in the top retainer and slip the retainer up until the filter can be removed. Re-install by placing the frame in its track, rotating the retainer back down and tighten all screws.

SUPPLY FAN (BLOWER) SECTION

⚠ WARNING

ELECTRICAL SHOCK HAZARD

Failure to follow this warning could cause personal injury or death.

Before performing service or maintenance operations on the fan system, shut off all unit power and tag-out the unit disconnect switch. Do not reach into the fan section with power still applied to unit.

Supply Fan (Belt-Drive)

The supply fan system consists of a forward-curved centrifugal blower wheel on a solid shaft with two concentric type bearings, one on each side of the blower housing. A fixed-pitch driver pulley is attached to the fan shaft and an adjustable-pitch driver pulley is on the motor. The pulleys are connected using a “V” type belt. (See Fig. 5.)

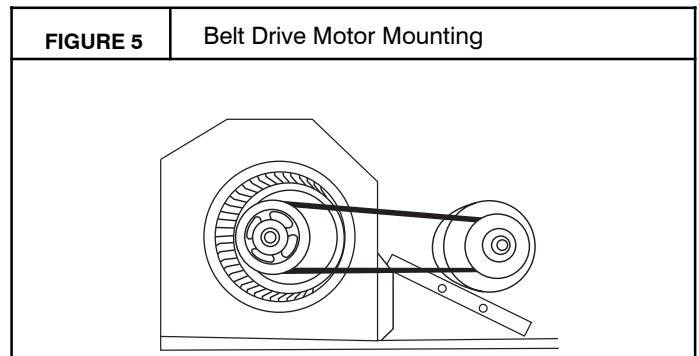

Belt

Check the belt condition and tension quarterly. Inspect the belt for signs of cracking, fraying or glazing along the inside surfaces. Check belt tension by using a spring-force tool (such as Browning’s Part Number “Belt Tension Checker” or equivalent tool); tension should be 6-lbs at a 5/8-in. deflection when measured at the centerline of the belt span. This point is at the center of the belt when measuring the distance between the motor shaft and the blower shaft.

NOTE: Without the spring-tension tool, place a straight edge across the belt surface at the pulleys, then deflect the belt at mid-span using one finger to a 1/2-in. deflection.

Adjust belt tension by loosening the motor mounting plate front bolts and rear bolt and sliding the plate toward the fan (to reduce tension) or away from fan (to increase tension). Ensure the blower shaft and the motor shaft are parallel to each other (pulleys aligned). Tighten all bolts when finished.

To replace the belt:

1. Use a belt with same section type or similar size. Do not substitute a “FHP” type belt. When installing the new belt, do not use a tool (screwdriver or pry-bar) to force the belt over the pulley flanges, this will stress the belt and cause a reduction in belt life.
2. Loosen the motor mounting plate front bolts and rear bolts.
3. Push the motor and its mounting plate towards the blower housing as close as possible to reduce the center distance between fan shaft and motor shaft.
4. Remove the belt by gently lifting the old belt over one of the pulleys.
5. Install the new belt by gently sliding the belt over both pulleys and then sliding the motor and plate away from the fan housing until proper tension is achieved.
6. Check the alignment of the pulleys, adjust if necessary.
7. Tighten all bolts.
8. Check the tension after a few hours of runtime and re-adjust as required.

Adjustable-Pitch Pulley on Motor

The motor pulley is an adjustable-pitch type that allows a servicer to implement changes in the fan wheel speed to match as-installed ductwork systems. The pulley consists of a fixed flange side that faces the motor (secured to the motor shaft) and a movable flange side that can be rotated around the fixed flange side that increases or reduces the pitch diameter of this driver pulley. (See Fig. 6.)

As the pitch diameter is changed by adjusting the position of the movable flange, the centerline on this pulley shifts laterally (along the motor shaft). This creates a requirement for a realignment of the pulleys after any adjustment of the movable flange. Also reset the belt tension after each realignment.

Check the condition of the motor pulley for signs of wear. Glazing of the belt contact surfaces and erosion on these surfaces are signs of improper belt tension and/or belt slippage. Pulley replacement may be necessary.

To change fan speed:

1. Shut off unit power supply.
2. Loosen belt by loosening fan motor mounting nuts. (See Fig. 5.)
3. Loosen movable pulley flange setscrew. (See Fig. 6.)
4. Screw movable flange toward fixed flange to increase speed and away from fixed flange to decrease speed. Increasing fan speed increases load on motor. Do not exceed maximum speed specified.
5. Set movable flange at nearest keyway of pulley hub and tighten setscrew to torque specifications.

To align fan and motor pulleys:

1. Loosen fan pulley setscrews.
2. Slide fan pulley along fan shaft. Make angular alignment by loosening motor from mounting.
3. Tighten fan pulley setscrews and motor mounting bolts to torque specifications.
4. Recheck belt tension.

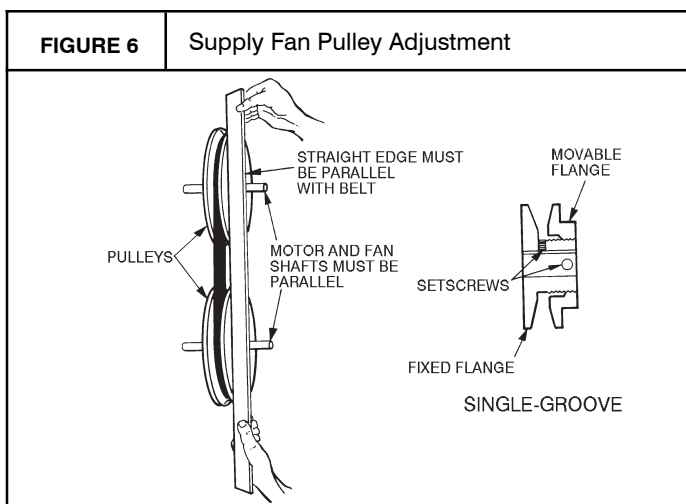

Bearings

This fan system uses bearings featuring concentric split locking collars. The collars are tightened through a cap screw bridging the split portion of the collar. The cap screw has a Torx T25

socket head. To tighten the locking collar: Hold the locking collar tightly against the inner race of the bearing and torque the cap screw to 65-70 in-lb (7.4-7.9 Nm). See Fig. 7.



Motor

When replacing the motor, also replace the external-tooth lock washer (star washer) under the motor mounting base; this is part of the motor grounding system. Ensure the teeth on the lock washer are in contact with the motor's painted base. Tighten motor mounting bolts to 120 +/- 12 in-lbs.

Changing fan wheel speed by changing pulleys: The horsepower rating of the belt is primarily dictated by the pitch diameter of the smaller pulley in the drive system (typically the motor pulley in these units). Do not install a replacement motor pulley with a smaller pitch diameter than provided on the original factory pulley. Change fan wheel speed by changing the fan pulley (larger pitch diameter to reduce wheel speed, smaller pitch diameter to increase wheel speed) or select a new system (both pulleys and matching belt(s)).

Before changing pulleys to increase fan wheel speed, check the fan performance at the target speed and airflow rate to determine new motor loading (bhp). Use the fan performance tables or use the Packaged Rooftop Builder software program. Confirm that the motor in this unit is capable of operating at the new operating condition. Fan shaft loading increases dramatically as wheel speed is increased.

To reduce vibration, replace the motor's adjustable pitch pulley with a fixed pitch pulley (after the final airflow balance adjustment). This will reduce the amount of vibration generated by the motor/belt-drive system.

COOLING

▲ WARNING

UNIT OPERATION AND SAFETY HAZARD

Failure to follow this warning could cause personal injury, death and/or equipment damage.

This system uses R-410A refrigerant which has higher pressures than R-22 and other refrigerants. No other refrigerant may be used in this system. Gauge set, hoses, and recovery system must be designed to handle R-410A refrigerant. If unsure about equipment, consult the equipment manufacturer.

Condenser Coil

The condenser coil is fabricated with round tube copper hairpins and plate fins of various materials and/or coatings (see Model Number Format in the Appendix to identify the materials provided in this unit). The coil may be one-row or composite-type two-row. Composite two-row coils are two single-row coils fabricated with a single return bend end tubesheet.

Condenser Coil Maintenance and Cleaning Recommendation

Routine cleaning of coil surfaces is essential to maintain proper operation of the unit. Elimination of contamination and removal of harmful residues will greatly increase the life of the coil and extend the life of the unit. The following maintenance and cleaning procedures are recommended as part of the routine maintenance activities to extend the life of the coil.

Remove Surface Loaded Fibers

Surface loaded fibers or dirt should be removed with a vacuum cleaner. If a vacuum cleaner is not available, a soft non-metallic bristle brush may be used. In either case, the tool should be applied in the direction of the fins. Coil surfaces can be easily damaged (fin edges can be easily bent over and damage to the coating of a protected coil) if the tool is applied across the fins.

NOTE: Use of a water stream, such as a garden hose, against a surface loaded coil will drive the fibers and dirt into the coil. This will make cleaning efforts more difficult. Surface loaded fibers must be completely removed prior to using low velocity clean water rinse.

Periodic Clean Water Rinse

A periodic clean water rinse is very beneficial for coils that are applied in coastal or industrial environments. However, it is very important that the water rinse is made with a very low velocity water stream to avoid damaging the fin edges. Monthly cleaning as described below is recommended.

Routine Cleaning of Coil Surfaces

Periodic cleaning with Fast Parts® environmentally sound coil cleaner is essential to extend the life of coils. This cleaner is available from ICP Fast Parts as part number P902-0301 for a one gallon container, and part number P902-0305 for a 5 gallon container. It is recommended that all coils, including standard aluminum, pre-coated, copper/copper or E-coated coils be cleaned with the Fast Parts environmentally sound coil cleaner as described below. Coil cleaning should be part of the unit's regularly scheduled maintenance procedures to ensure long life of the coil. Failure to clean the coils may result in reduced durability in the environment.

Avoid use of:

- coil brighteners
- acid cleaning prior to painting
- high pressure washers
- poor quality water for cleaning

Fast Parts environmentally sound coil cleaner is nonflammable, hypo allergenic, non bacterial, and a USDA accepted biodegradable agent that will not harm the coil or surrounding components such as electrical wiring, painted metal surfaces, or insulation. Use of non-recommended coil cleaners is strongly discouraged since coil and unit durability could be affected.

One-Row Coil

Wash coil with commercial coil cleaner. It is not necessary to remove top panel.

Two-Row Coils

Clean coil as follows:

1. Turn off unit power, tag disconnect.
2. Remove top panel screws on condenser end of unit.
3. Remove condenser coil corner post. See Fig. 8. To hold top panel open, place coil corner post between top panel and center post. See Fig. 9.
4. Remove screws securing coil to compressor plate and compressor access panel.
5. Remove fastener holding coil sections together at return end of condenser coil. Carefully separate the outer coil section 3 to 4 in. from the inner coil section. See Fig. 10.
6. Use a water hose or other suitable equipment to flush down between the 2 coil sections to remove dirt and debris. Clean the outer surfaces with a stiff brush in the normal manner.
7. Secure inner and outer coil rows together with a field-supplied fastener.
8. Reposition the outer coil section and remove the coil corner post from between the top panel and center post. Reinstall the coil corner post and replace all screws.

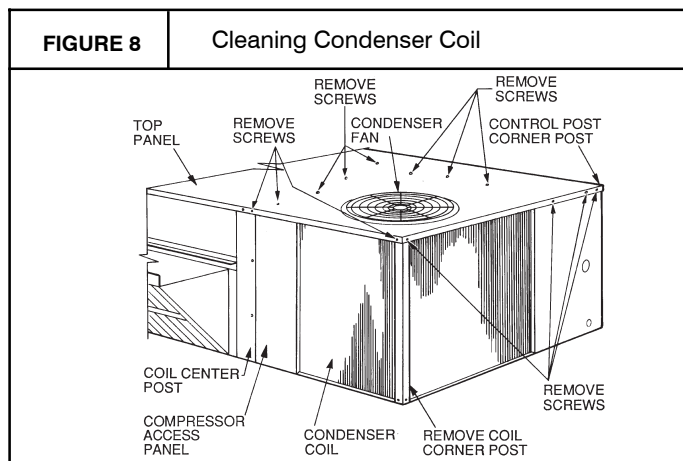

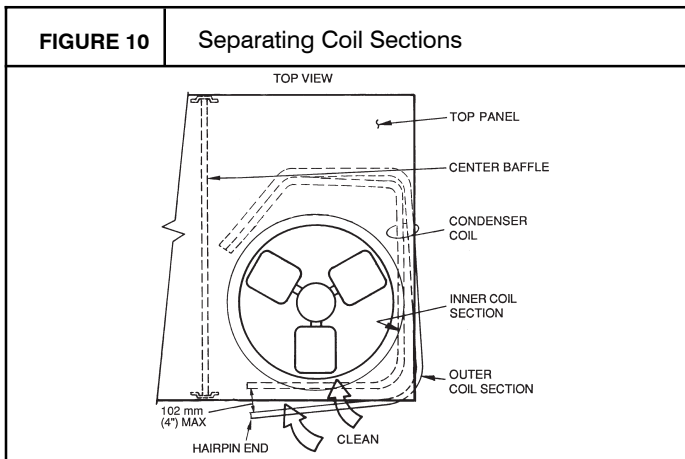
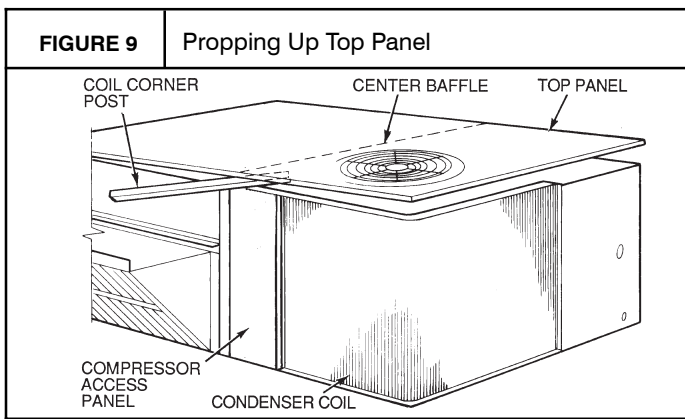

Fast Parts Environmentally Sound Coil Cleaner Application Equipment

- 2-1/2 gallon garden sprayer
- Water rinse with low velocity spray nozzle

⚠ CAUTION

UNIT DAMAGE HAZARD

Failure to follow this caution may result in accelerated corrosion of unit parts.

Harsh chemicals, household bleach or acid or basic cleaners should not be used to clean outdoor or indoor coils of any kind. These cleaners can be very difficult to rinse out of the coil and can accelerate corrosion at the fin/tube interface where dissimilar materials are in contact. If there is dirt below the surface of the coil, use the Fast Parts environmentally sound coil cleaner.

⚠ CAUTION

UNIT DAMAGE HAZARD

Failure to follow this caution may result in reduced unit performance or unit shutdown.

High velocity water from a pressure washer, garden hose, or compressed air should never be used to clean a coil. The force of the water or air jet will bend the fin edges and increase airside pressure drop.

Fast Parts Environmentally Sound Coil Cleaner Application Instructions

1. Proper eye protection such as safety glasses is recommended during mixing and application.

2. Remove all surface loaded fibers and dirt with a vacuum cleaner as described above.
3. Thoroughly wet finned surfaces with clean water and a low velocity garden hose, being careful not to bend fins.
4. Mix Fast Parts environmentally sound coil cleaner in a 2-1/2 gallon garden sprayer according to the instructions included with the cleaner. The optimum solution temperature is 100°F.

NOTE: Do NOT USE water in excess of 130°F, as the enzymatic activity will be destroyed.

5. Thoroughly apply Fast Parts environmentally sound coil cleaner solution to all coil surfaces including finned area, tube sheets and coil headers.
6. Hold garden sprayer nozzle close to finned areas and apply cleaner with a vertical, up-and-down motion. Avoid spraying in horizontal pattern to minimize potential for fin damage.
7. Ensure cleaner thoroughly penetrates deep into finned areas.
8. Interior and exterior finned areas must be thoroughly cleaned.
9. Finned surfaces should remain wet with cleaning solution for 10 minutes.
10. Ensure surfaces are not allowed to dry before rinsing. Re-applying cleaner as needed to ensure 10-minute saturation is achieved.
11. Thoroughly rinse all surfaces with low velocity clean water using downward rinsing motion of water spray nozzle. Protect fins from damage from the spray nozzle.

Evaporator Coil

Cleaning the Evaporator Coil

1. Turn unit power off. Install lockout tag. Remove evaporator coil access panel.
2. If economizer or two-position damper is installed, remove economizer by disconnecting Molex plug and removing mounting screws.
3. Slide filters out of unit.
4. Clean coil using a commercial coil cleaner or dishwasher detergent in a pressurized spray canister. Wash both sides of coil and flush with clean water. For best results, back-flush toward return-air section to remove foreign material. Flush condensate pan after completion.
5. Reinstall economizer and filters.
6. Reconnect wiring.
7. Replace access panels.

Evaporator Coil Metering Devices

The metering devices are multiple fixed-bore devices (Acutrol™) swedged into the horizontal outlet tubes from the liquid header, located at the entrance to each evaporator coil circuit path. These are non-adjustable. Service requires replacing the entire liquid header assembly.

To check for possible blockage of one or more of these metering devices, disconnect the supply fan contactor (IFC) coil, then start the compressor and observe the frosting pattern on the face of the evaporator coil. A frost pattern should develop uniformly across the face of the coil starting at each

horizontal header tube. Failure to develop frost at an outlet tube can indicate a plugged or a missing orifice.

Refrigerant System Pressure Access Ports

There are two access ports in the system - on the suction tube near the compressor and on the discharge tube near the compressor. These are brass fittings with black plastic caps. The hose connection fittings are standard 1/4 SAE Male Flare couplings.

The brass fittings are two-piece High Flow valves, with a receptacle base brazed to the tubing and an integral spring-closed check valve core screwed into the base. (See Fig. 11.) This check valve is permanently assembled into this core body and cannot be serviced separately; replace the entire core body if necessary. Service tools are available from Fast Parts that allow the replacement of the check valve core without having to recover the entire system refrigerant charge. Apply compressor refrigerant oil to the check valve core's bottom o-ring. Install the fitting body with 96 +/-10 in-lbs of torque; do not overtighten.

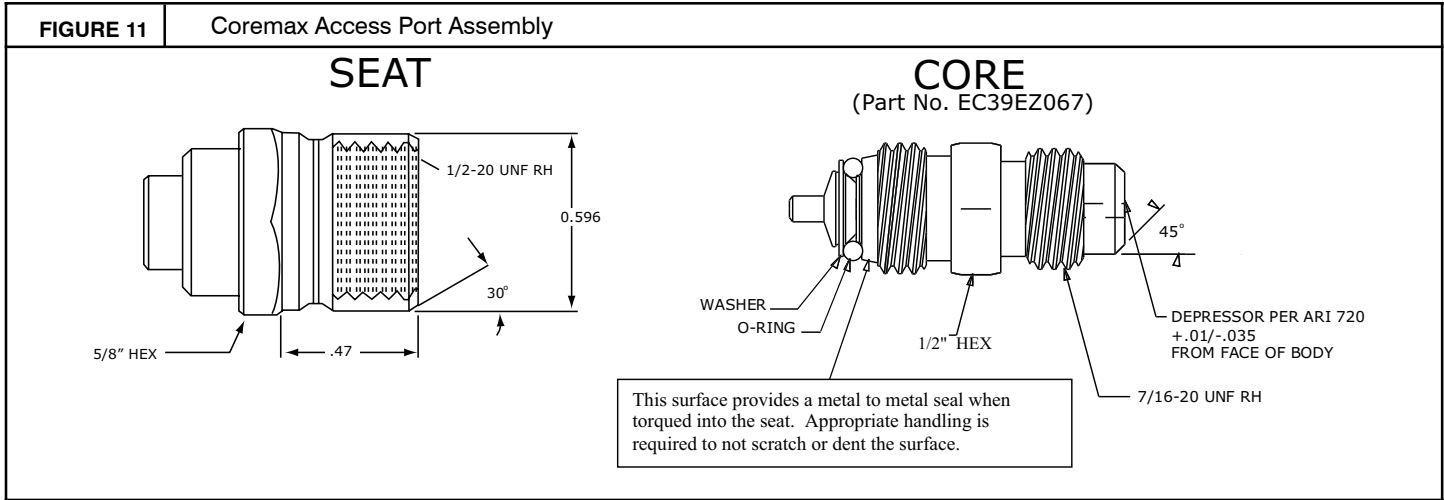

R-410A REFRIGERANT

This unit is designed for use with R-410A refrigerant. Do not use any other refrigerant in this system.

R-410A is provided in pink (rose) colored cylinders. These cylinders are available with and without dip tubes; cylinders with dip tubes will have a label indicating this feature. For a cylinder with a dip tube, place the cylinder in the upright position (access valve at the top) when removing liquid refrigerant for charging. For a cylinder without a dip tube, invert the cylinder (access valve on the bottom) when removing liquid refrigerant.

Because R-410A is a blend, it is strongly recommended that refrigerant always be removed from the cylinder as a liquid. Admit liquid refrigerant into the system in the discharge line. If adding refrigerant into the suction line, use a commercial metering/expansion device at the gauge manifold; remove liquid from the cylinder, pass it through the metering device at the gauge set and then pass it into the suction line as a vapor. Do not remove R-410A from the cylinder as a vapor.

Refrigerant Charge

Amount of refrigerant charge is listed on the unit's nameplate. Refer to GTAC2-5 Charging, Recovery, Recycling and Reclamation training manual and the following procedures.

Unit panels must be in place when unit is operating during the charging procedure.

No Charge

Use standard evacuating techniques. After evacuating system, weigh in the specified amount of refrigerant.

Low-Charge Cooling

Using Cooling Charging Charts, Fig. 12, vary refrigerant until the conditions of the appropriate chart are met. Note the charging charts are different from type normally used. Charts are based on charging the units to the correct superheat for the various operating conditions. Accurate pressure gauge and temperature sensing device are required. Connect the pressure gauge to the service port on the suction line. Mount the temperature sensing device on the suction line and insulate it so that outdoor ambient temperature does not affect the reading. Indoor-air cfm must be within the normal operating range of the unit.

To Use Cooling Charging Charts

Take the outdoor ambient temperature and read the suction pressure gauge. Refer to chart to determine what suction temperature should be. If suction temperature is high, add refrigerant. If suction temperature is low, carefully recover some of the charge. Recheck the suction pressure as charge is adjusted.

SIZE DESIGNATION	NOMINAL TONS
036	3
048	4
060	5
072	6
091	7.5
101	8.5
121	10

EXAMPLE:

- Model RGS036 (3 ton)
- Outdoor Temperature 85°F (29°C)
- Suction Pressure 140 psig (965 kPa)
- Suction Temperature should be 60°F (16°C)

COOLING CHARGING CHARTS

FIGURE 12

Cooling Charging Charts – 3 & 4 Ton

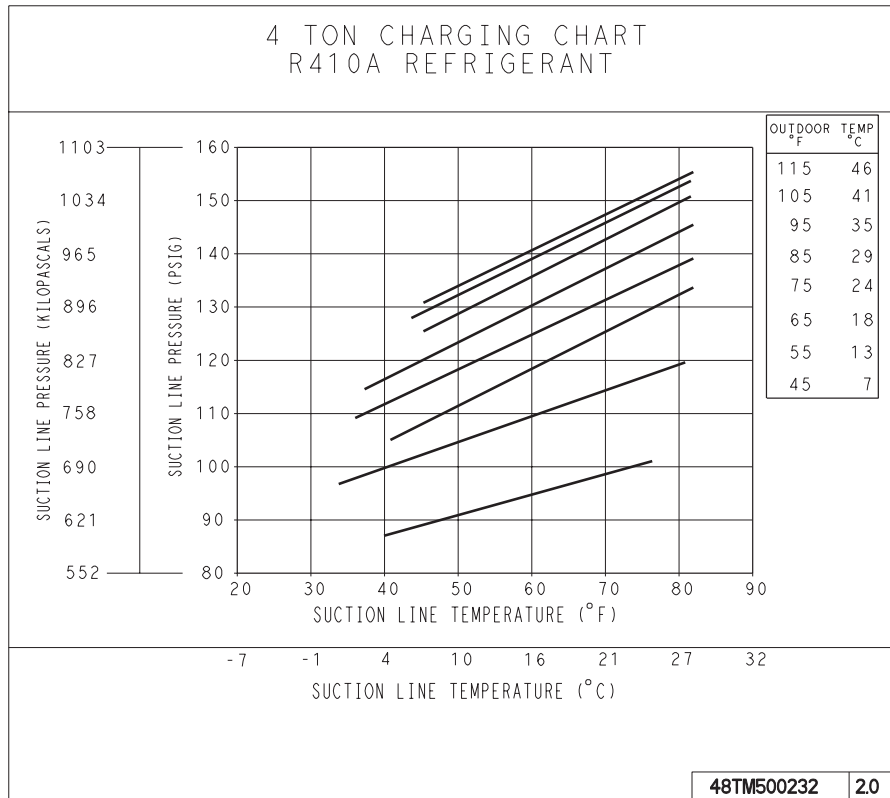
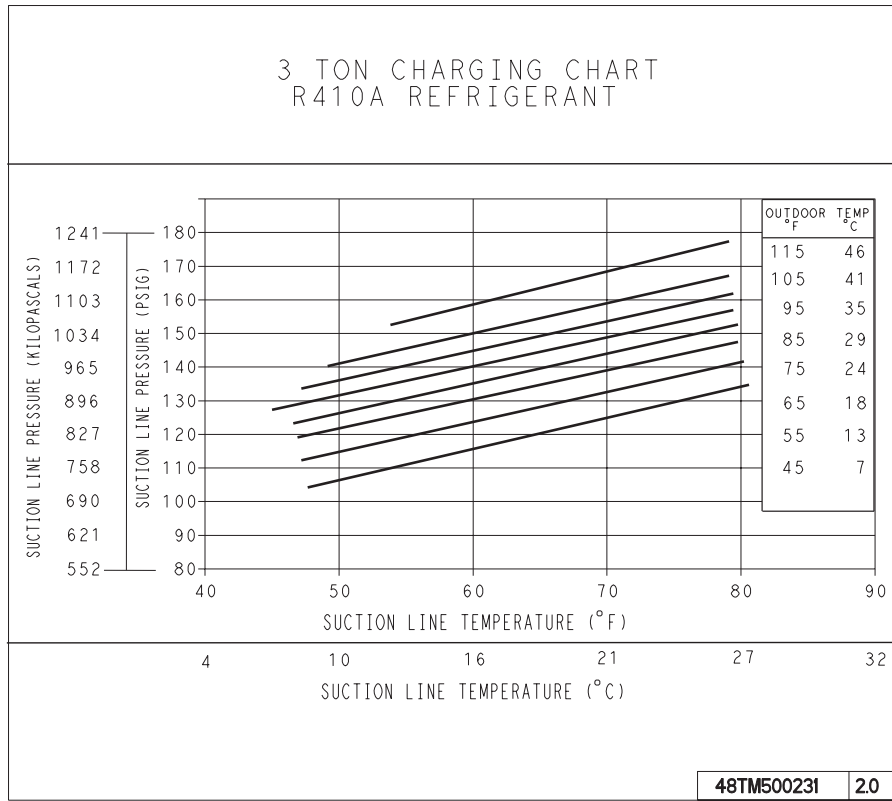

Fig. 12

Cooling Charging Charts – 5 & 6 Ton

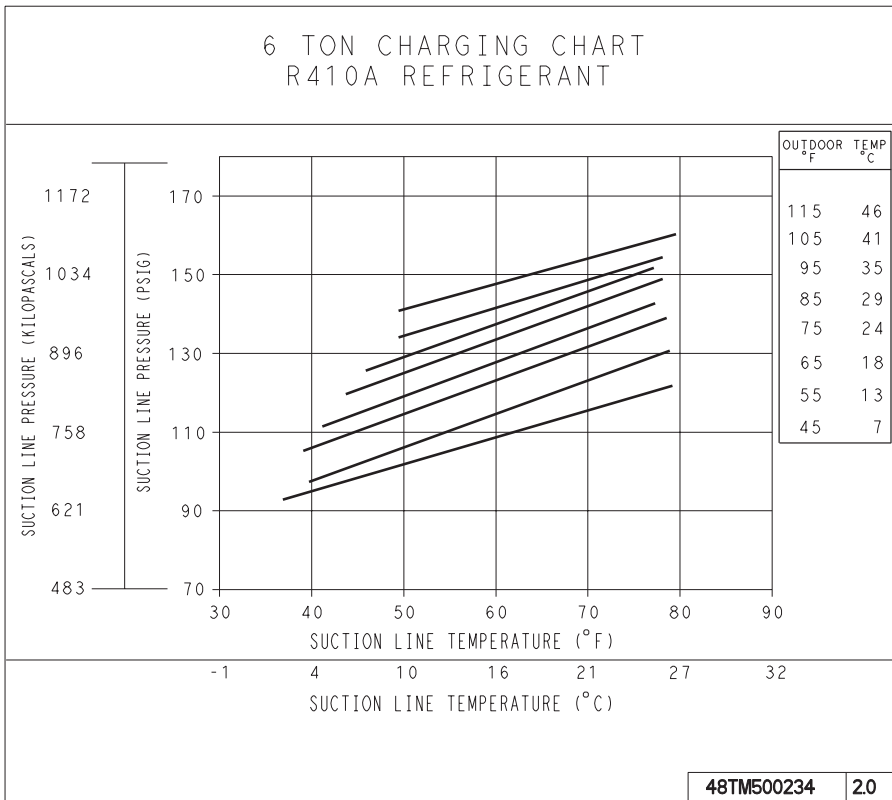
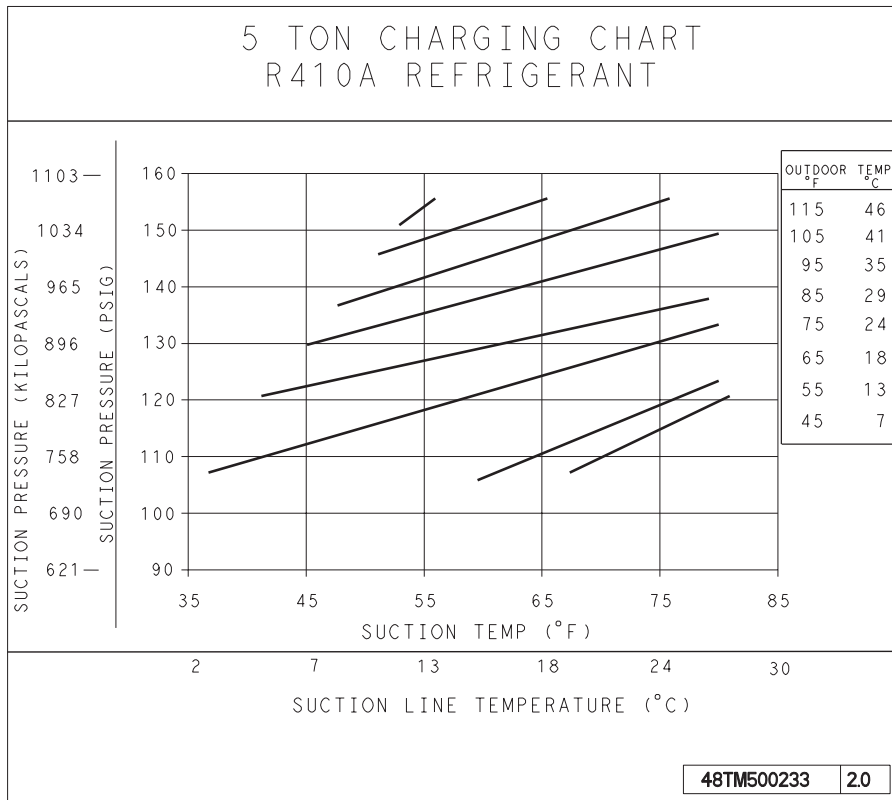
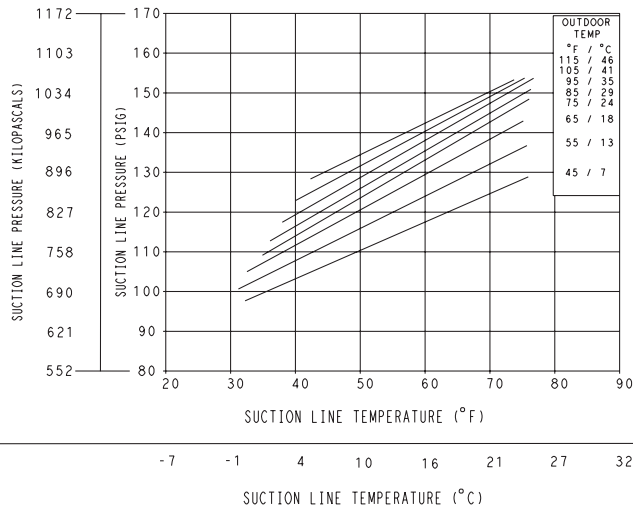

Fig. 12

Cooling Charging Charts – 7.5 & 8.5 Ton

7.5 TON CHARGING CHART
R410A REFRIGERANT



48TM500885 2.0

8.5 TON CHARGING CHART
R410A REFRIGERANT

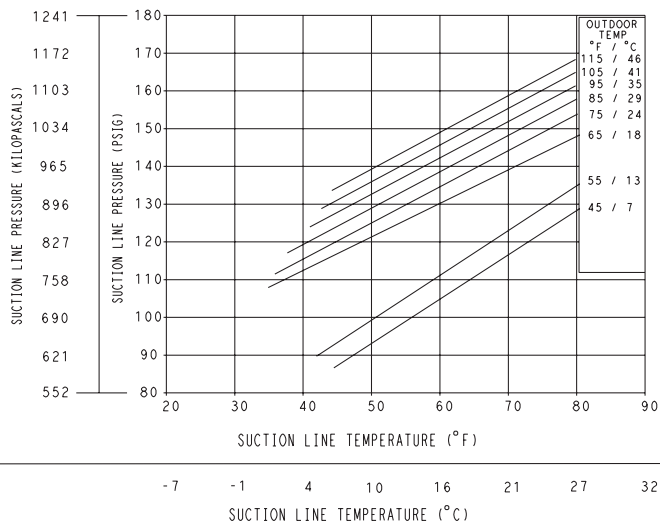

48TM500886 2.0

Fig. 12

Cooling Charging Charts – 10 Ton

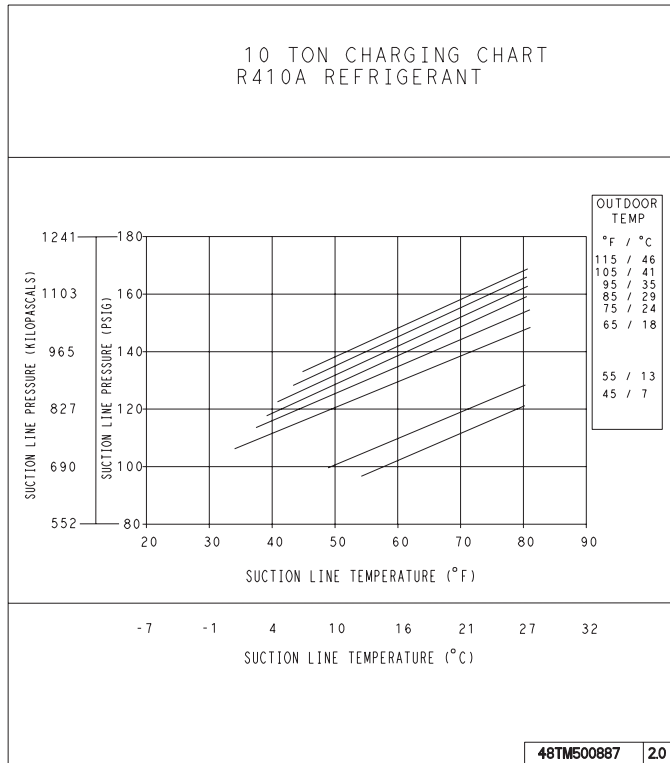
**Compressor****Lubrication**

The compressor is charged with the correct amount of oil at the factory.

▲ CAUTION

UNIT DAMAGE HAZARD

Failure to follow this caution may result in damage to components.

The compressor is in a R-410A refrigerant system and uses a polyolester (POE) oil. This oil is extremely hygroscopic, meaning it absorbs water readily. POE oils can absorb 15 times as much water as other oils designed for HCFC and CFC refrigerants. Avoid exposure of the oil to the atmosphere.

Replacing Compressor

The compressor used with R-410A refrigerant contains a POE oil. This oil has a high affinity for moisture. Do not remove the compressor's tube plugs until ready to insert the unit suction and discharge tube ends.

Compressor mounting bolt torque is 65-75 ft-lbs.

Compressor Rotation

On 3-phase units with scroll compressors, it is important to be certain compressor is rotating in the proper direction. To determine whether or not compressor is rotating in the proper direction:

1. Connect service gauges to suction and discharge pressure fittings.
2. Energize the compressor.
3. The suction pressure should drop and the discharge pressure should rise, as is normal on any start-up.

NOTE: If the suction pressure does not drop and the discharge pressure does not rise to normal levels:

4. Note that the evaporator fan is probably also rotating in the wrong direction.
5. Turn off power to the unit.
6. Reverse any two of the unit power leads.
7. Reapply power to the compressor.

The suction and discharge pressure levels should now move to their normal start-up levels.

NOTE: When the compressor is rotating in the wrong direction, the unit makes an elevated level of noise and does not provide cooling.

Filter Drier

Replace whenever refrigerant system is exposed to atmosphere. Only use factory specified liquid-line filter driers with working pressures no less than 650 psig. Do not install a suction-line filter drier in liquid line. A liquid-line filter drier designed for use with R-410A refrigerant is required on every unit.

Condenser-Fan Location

See Fig. 13.

1. Shut off unit power supply. Install lockout tag.
2. Remove condenser-fan assembly (grille, motor, and fan).
3. Loosen fan hub setscrews.
4. Adjust fan height as shown in Fig. 13.
5. Tighten setscrews.
6. Replace condenser-fan assembly.

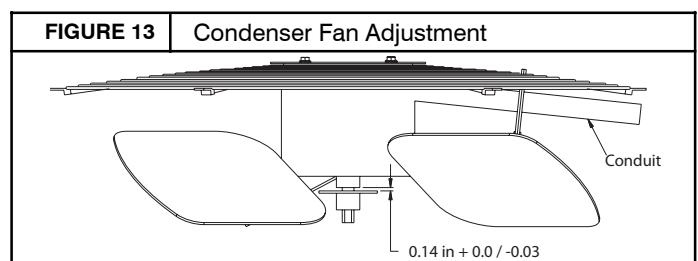

Troubleshooting Cooling System

Table 1 – Cooling Service Analysis

PROBLEM	CAUSE	REMEDY
Compressor and Condenser Fan Will Not Start.	Power failure.	Call power company.
	Fuse blown or circuit breaker tripped.	Replace fuse or reset circuit breaker.
	Defective thermostat, contactor, transformer, or control relay.	Replace component.
	Insufficient line voltage.	Determine cause and correct.
	Incorrect or faulty wiring.	Check wiring diagram and rewire correctly.
	Thermostat setting too high.	Lower thermostat setting below room temperature.
Compressor Will Not Start But Condenser Fan Runs.	Faulty wiring or loose connections in compressor circuit.	Check wiring and repair or replace.
	Compressor motor burned out, seized, or internal overload open.	Determine cause. Replace compressor.
	Defective run/start capacitor, overload, start relay.	Determine cause and replace.
	One leg of three-phase power dead.	Replace fuse or reset circuit breaker. Determine cause.
Compressor Cycles (other than normally satisfying thermostat).	Refrigerant overcharge or undercharge.	Recover refrigerant, evacuate system, and recharge to nameplate.
	Defective compressor.	Replace and determine cause.
	Insufficient line voltage.	Determine cause and correct.
	Blocked condenser.	Determine cause and correct.
	Defective run/start capacitor, overload, or start relay.	Determine cause and replace.
	Defective thermostat.	Replace thermostat.
	Faulty condenser – fan motor or capacitor.	Replace.
Restriction in refrigerant system.	Locate restriction and remove.	
Compressor Operates Continuously.	Dirty air filter.	Replace filter.
	Unit undersized for load.	Decrease load or increase unit size.
	Thermostat set too low.	Reset thermostat.
	Low refrigerant charge.	Locate leak; repair and recharge.
	Leaking valves in compressor.	Replace compressor.
	Air in system.	Recover refrigerant, evacuate system, and recharge.
	Condenser coil dirty or restricted.	Clean coil or remove restriction.
Excessive Head Pressure.	Dirty air filter.	Replace filter.
	Dirty condenser coil.	Clean coil.
	Refrigerant overcharged.	Recover excess refrigerant.
	Air in system.	Recover refrigerant, evacuate system, and recharge.
	Condenser air restricted or air short – cycling.	Determine cause and correct.
Head Pressure Too Low.	Low refrigerant charge.	Check for leaks; repair and recharge.
	Compressor valves leaking.	Replace compressor.
	Restriction in liquid tube.	Remove restriction.
Excessive Suction Pressure.	High head load.	Check for source and eliminate.
	Compressor valves leaking.	Replace compressor.
	Refrigerant overcharged.	Recover excess refrigerant.
Suction Pressure Too Low.	Dirty air filter.	Replace filter.
	Low refrigerant charge.	Check for leaks; repair and recharge.
	Metering device or low side restricted.	Remove source of restriction.
	Insufficient evaporator airflow.	Increase air quantity. Check filter and replace if necessary.
	Temperature too low in conditioned area.	Reset thermostat.
	Outdoor ambient below 25° F.	Install low-ambient kit.
Evaporator Fan Will Not Shut Off.	Time off delay not finished.	Wait for 30-second off delay.
Compressor Makes Excessive Noise.	Compressor rotating in wrong direction.	Reverse the 3-phase power leads.

CONVENIENCE OUTLETS (Optional)

⚠ WARNING

ELECTRICAL OPERATION HAZARD

Failure to follow this warning could result in personal injury or death.

Units with convenience outlet circuits may use multiple disconnects. Check convenience outlet for power status before opening unit for service. Locate its disconnect switch, if appropriate, and open it. Tag-out this switch, if necessary.

The factory installed option (FIOP) non-powered 115v convenience outlet provide a 125-volt GFCI (ground-fault circuit-interrupter) duplex receptacle rated at 15-A behind a hinged waterproof access cover, located on the end panel of the unit. See Fig. 14.

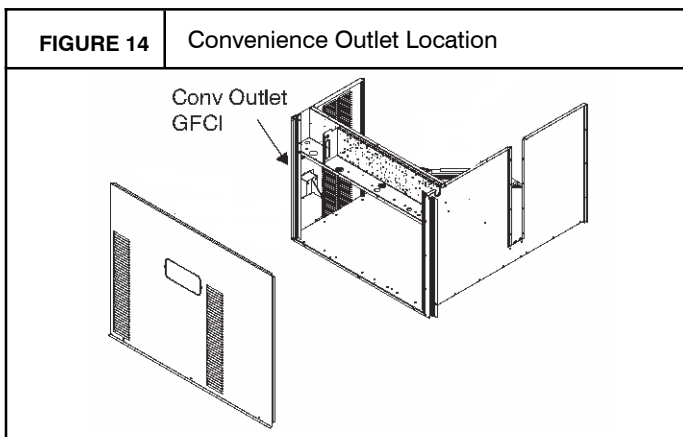

Non-powered type: This type requires the field installation of a general-purpose 125-volt 15-A circuit powered from a source elsewhere in the building. Observe national and local codes when selecting wire size, fuse or breaker requirements and disconnect switch size and location. Route 125-v power supply conductors into the bottom of the utility box containing the duplex receptacle.

Maintenance: Periodically test the GFCI receptacle by pressing the TEST button on the face of the receptacle. This should cause the internal circuit of the receptacle to trip and open the receptacle. Check for proper grounding wires and power line phasing if the GFCI receptacle does not trip as required. Press the RESET button to clear the tripped condition.

Using unit-mounted convenience outlets: Units with unit-mounted convenience outlet circuits will often require that two disconnects be opened to de-energize all power to the unit. Treat all units as electrically energized until the convenience outlet power is also checked and de-energization is confirmed. Observe National Electrical Code Article 210, Branch Circuits, for use of convenience outlets.

SMOKE DETECTORS

Smoke detectors are available as factory-installed options on RGS models. Smoke detectors for Supply Air only without or with economizer. All components necessary for operation are factory-provided and mounted. The unit is factory-configured for immediate smoke detector shutdown operation; additional

wiring or modifications to unit terminal board may be necessary to complete the unit and smoke detector configuration to meet project requirements.

System

The smoke detector system consists of a four-wire controller and one or two sensors. Its primary function is to shut down the rooftop unit in order to prevent smoke from circulating throughout the building. It is not to be used as a life saving device.

Controller

The controller (see Fig. 15) includes a controller housing, a printed circuit board, and a clear plastic cover. The controller can be connected to one or two compatible duct smoke sensors. The clear plastic cover is secured to the housing with a single captive screw for easy access to the wiring terminals. The controller has three LEDs (for Power, Trouble and Alarm) and a manual test/reset button (on the cover face).

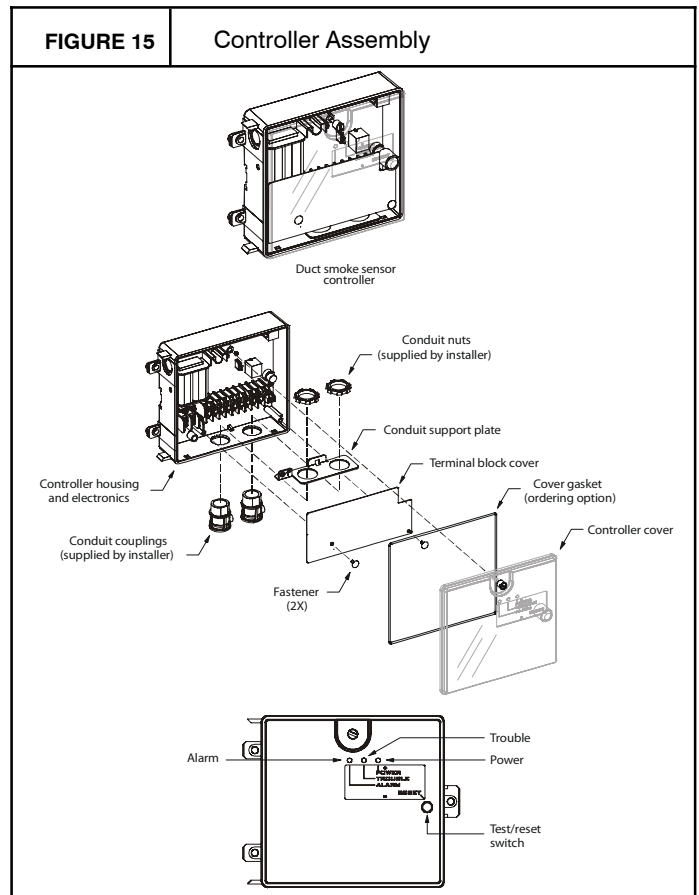

Sensor

The sensor (see Fig. 16) includes a plastic housing, a printed circuit board, a clear plastic cover, a sampling tube inlet and an exhaust tube. The sampling tube (when used) and exhaust tube are attached during installation. The sampling tube varies in length depending on the size of the rooftop unit. The clear plastic cover permits visual inspections without having to disassemble the sensor. The cover attaches to the sensor housing using four captive screws and forms an airtight chamber around the sensing electronics. Each sensor includes a harness with an RJ45 terminal for connecting to the controller. Each sensor has four LEDs (for Power, Trouble, Alarm and Dirty) and a manual test/reset button (on the left-side of the housing).

FIGURE 16

Smoke Detector Sensor

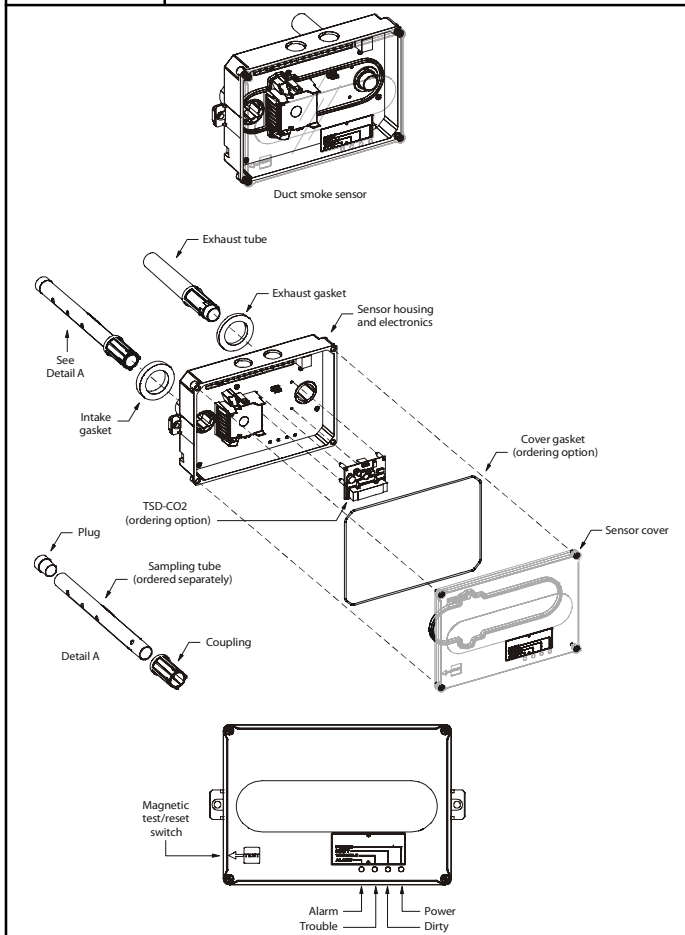

Air is introduced to the duct smoke detector sensor's sensing chamber through a sampling tube that extends into the HVAC duct and is directed back into the ventilation system through a (shorter) exhaust tube. The difference in air pressure between the two tubes pulls the sampled air through the sensing chamber. When a sufficient amount of smoke is detected in the sensing chamber, the sensor signals an alarm state and the controller automatically takes the appropriate action to shut down fans and blowers, change over air handling systems, notify the fire alarm control panel, etc.

The sensor uses a process called differential sensing to prevent gradual environmental changes from triggering false alarms. A rapid change in environmental conditions, such as smoke from a fire, causes the sensor to signal an alarm state but dust and debris accumulated over time does not.

For installations using two sensors, the duct smoke detector does not differentiate which sensor signals an alarm or trouble condition.

Smoke Detector Locations

Supply Air — The Supply Air smoke detector sensor is located to the left of the unit's indoor (supply) fan. See Fig. 17. Access is through the fan access panel. There is no sampling tube used at this location. The sampling tube inlet extends through the side plate of the fan housing (into a high pressure area). The controller is located on a bracket to the right of the return filter, accessed through the lift-off filter panel.

FIGURE 17

Typical Supply Air Smoke Detector Sensor Location

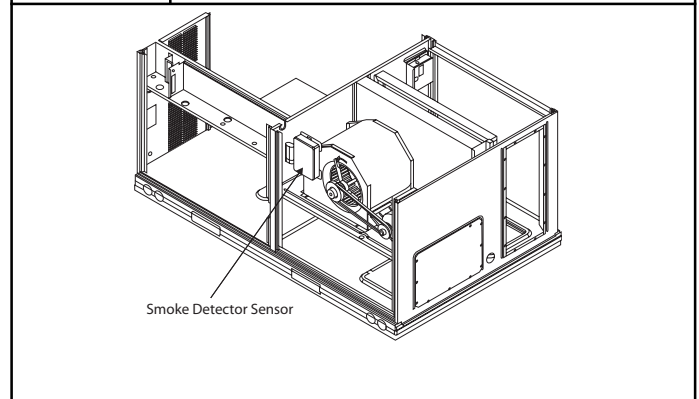

FIOP Smoke Detector Wiring and Response

All units: FIOP smoke detector is configured to automatically shut down all unit operations when smoke condition is detected. See Fig. 18, Smoke Detector Wiring.

Highlight A: JMP 3 is factory-cut, transferring unit control to smoke detector.

Highlight B: Smoke detector NC contact set will open on smoke alarm condition, de-energizing the ORN conductor.

Highlight C: 24-v power signal via ORN lead is removed at Smoke Detector input on LCTB; all unit operations cease immediately.

Using Remote Logic: Five conductors are provided for field use (see Highlight D) for additional annunciation functions.

Additional Application Data — Refer to Catalog No. HKRNKA-1XA for discussions on additional control features of these smoke detectors including multiple unit coordination. See Fig. 18.

FIGURE 18 Typical Smoke Detector Wiring

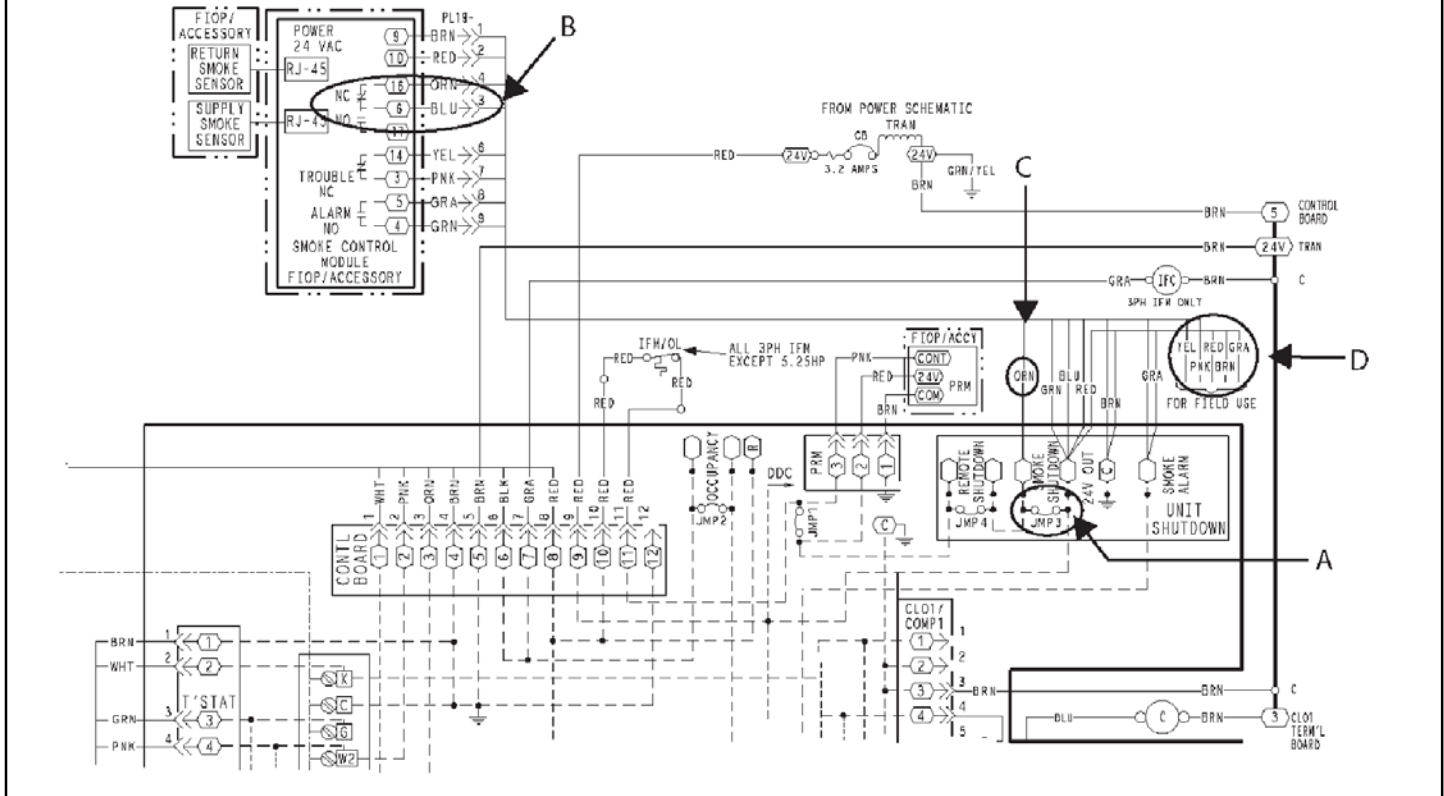

SENSOR AND CONTROLLER TESTS

Sensor Alarm Test

The sensor alarm test checks a sensor’s ability to signal an alarm state. This test requires that you use a SD-MAG test magnet. The magnet is supplied taped to the smoke detector for the Alarm Contractor’s use at the job site to verify operation once the alarm loop is connected. It is also used to reset the detector once it trips an alarm (during the building smoke test). If the customer utilizes the remote test/reset device (KT99ZT003 or CRSDTEST001A00), the magnet is transferred to the alarm panel room in the building to serve the same purpose.

⚠ CAUTION

OPERATIONAL TEST HAZARD

Failure to follow this caution may result in personnel and authority concern.

This test places the duct detector into the alarm state. Unless part of the test, disconnect all auxiliary equipment from the controller before performing the test. If the duct detector is connected to a fire alarm system, notify the proper authorities before performing the test.

Sensor Alarm Test Procedure

1. Hold the test magnet where indicated on the side of the sensor housing for seven seconds.
2. Verify that the sensor’s Alarm LED turns on.
3. Reset the sensor by holding the test magnet against the sensor housing for two seconds.
4. Verify that the sensor’s Alarm LED turns off.

Controller Alarm Test

The controller alarm test checks the controller’s ability to initiate and indicate an alarm state.

⚠ CAUTION

OPERATIONAL TEST HAZARD

Failure to follow this caution may result in personnel and authority concern.

This test places the duct detector into the alarm state. Disconnect all auxiliary equipment from the controller before performing the test. If the duct detector is connected to a fire alarm system, notify the proper authorities before performing the test.

Controller Alarm Test Procedure

1. Press the controller’s test/reset switch for seven seconds.
2. Verify that the controller’s Alarm LED turns on.
3. Reset the sensor by pressing the test/reset switch for two seconds.
4. Verify that the controller’s Alarm LED turns off.

Dirty Controller Test

The dirty controller test checks the controller’s ability to initiate a dirty sensor test and indicate its results.

⚠ CAUTION

OPERATIONAL TEST HAZARD

Failure to follow this caution may result in personnel and authority concern.

Pressing the controller’s test/reset switch for longer than seven seconds will put the duct detector into the alarm state and activate all automatic alarm responses.

Dirty Controller Test Procedure

1. Press the controller's test/reset switch for two seconds.
2. Verify that the controller's Trouble LED flashes.

Dirty Sensor Test

The dirty sensor test provides an indication of the sensor's ability to compensate for gradual environmental changes. A sensor that can no longer compensate for environmental changes is considered 100% dirty and requires cleaning or replacing. You must use the factory provided SD-MAG test magnet (taped to the smoke detector) to initiate a sensor dirty test. The sensor's Dirty LED indicates the results of the dirty test as shown in Table 2.

▲ CAUTION

OPERATIONAL TEST HAZARD

Failure to follow this caution may result in personnel and authority concern.

Holding the test magnet against the sensor housing for more than seven seconds will put the duct detector into the alarm state and activate all automatic alarm responses.

Table 2 – Dirty LED Test

FLASHES	DESCRIPTION
1	0–25% dirty. (Typical of a newly installed detector)
2	25–50% dirty
3	51–75% dirty
4	76–99% dirty

Dirty Sensor Test Procedure

1. Hold the test magnet where indicated on the side of the sensor housing for two seconds.
2. Verify that the sensor's Dirty LED flashes.

▲ CAUTION

OPERATIONAL TEST HAZARD

Failure to follow this caution may result in personnel and authority concern.

Changing the dirty sensor test operation will put the detector into the alarm state and activate all automatic alarm responses. Before changing dirty sensor test operation, disconnect all auxiliary equipment from the controller and notify the proper authorities if connected to a fire alarm system.

Changing the Dirt Sensor Test

By default, sensor dirty test results are indicated by:

- The sensor's Dirty LED flashing.
- The controller's Trouble LED flashing.
- The controller's supervision relay contacts toggle.

The operation of a sensor's dirty test can be changed so that the controller's supervision relay is not used to indicate test results. When two detectors are connected to a controller, sensor dirty

test operation on both sensors must be configured to operate in the same manner.

To Configure the Dirty Sensor Test Operation

1. Hold the test magnet where indicated on the side of the sensor housing until the sensor's Alarm LED turns on and its Dirty LED flashes twice (approximately 60 seconds).
2. Reset the sensor by removing the test magnet then holding it against the sensor housing again until the sensor's Alarm LED turns off (approximately 2 seconds).

Remote Station Test

The remote station alarm test checks a test/reset station's ability to initiate and indicate an alarm state.

▲ CAUTION

OPERATIONAL TEST HAZARD

Failure to follow this caution may result in personnel and authority concern.

This test places the duct detector into the alarm state. Unless part of the test, disconnect all auxiliary equipment from the controller before performing the test. If the duct detector is connected to a fire alarm system, notify the proper authorities before performing the test.

SD-TRK4 Remote Alarm Test Procedure

1. Turn the key switch to the RESET/TEST position for seven seconds.
2. Verify that the test/reset station's Alarm LED turns on.
3. Reset the sensor by turning the key switch to the RESET/TEST position for two seconds.
4. Verify that the test/reset station's Alarm LED turns off.

Remote Test/Reset Station Dirty Sensor Test

The test/reset station dirty sensor test checks the test/reset station's ability to initiate a sensor dirty test and indicate the results. It must be wired to the controller as shown in Fig. 19

and configured to operate the controller's supervision relay. For more information, see "Changing sensor dirty test operation."

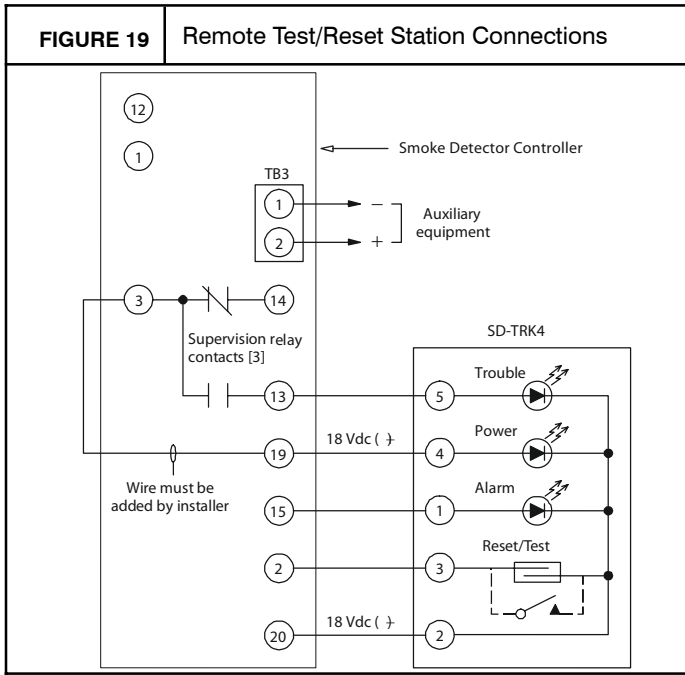

⚠ CAUTION

OPERATIONAL TEST HAZARD

Failure to follow this caution may result in personnel and authority concern.

If the test/reset station's key switch is left in the RESET/TEST position for longer than seven seconds, the detector will automatically go into the alarm state and activate all automatic alarm responses.

⚠ CAUTION

OPERATIONAL TEST HAZARD

Failure to follow this caution may result in personnel and authority concern.

Holding the test magnet to the target area for longer than seven seconds will put the detector into the alarm state and activate all automatic alarm responses.

Dirty Sensor Test Using an SD-TRK4

1. Turn the key switch to the RESET/TEST position for two seconds.
2. Verify that the test/reset station's Trouble LED flashes.

Detector Cleaning

Cleaning the Smoke Detector

Clean the duct smoke sensor when the Dirty LED is flashing continuously or sooner if conditions warrant.

Table 3 – Detector Indicators

CONTROL OR INDICATOR	DESCRIPTION
Magnetic test/reset switch	Resets the sensor when it is in the alarm or trouble state. Activates or tests the sensor when it is in the normal state.
Alarm LED	Indicates the sensor is in the alarm state.
Trouble LED	Indicates the sensor is in the trouble state.
Dirty LED	Indicates the amount of environmental compensation used by the sensor (flashing continuously = 100%)
Power LED	Indicates the sensor is energized.

⚠ CAUTION

OPERATIONAL TEST HAZARD

Failure to follow this caution may result in personnel and authority concern.

If the smoke detector is connected to a fire alarm system, first notify the proper authorities that the detector is undergoing maintenance then disable the relevant circuit to avoid generating a false alarm.

1. Disconnect power from the duct detector then remove the sensor's cover. (See Fig. 20.)

2. Using a vacuum cleaner, clean compressed air, or a soft bristle brush, remove loose dirt and debris from inside the sensor housing and cover.
Use isopropyl alcohol and a lint-free cloth to remove dirt and other contaminants from the gasket on the sensor's cover.
3. Squeeze the retainer clips on both sides of the optic housing then lift the housing away from the printed circuit board.
4. Gently remove dirt and debris from around the optic plate and inside the optic housing.
5. Replace the optic housing and sensor cover.

- Connect power to the duct detector then perform a sensor alarm test.

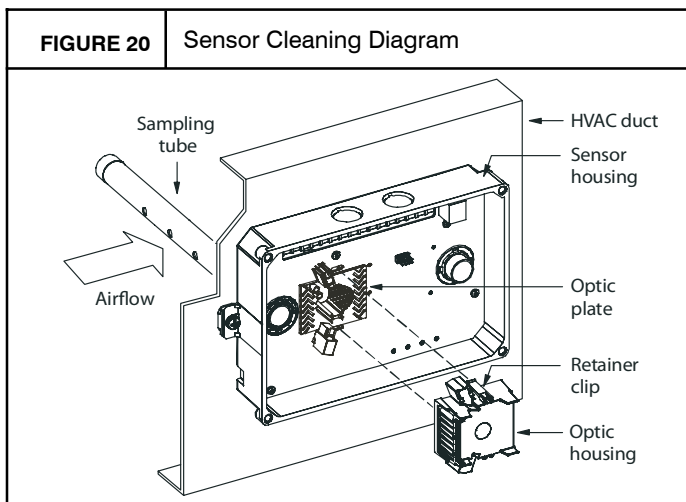

Indicators

Normal State

The smoke detector operates in the normal state in the absence of any trouble conditions and when its sensing chamber is free of smoke. In the normal state, the Power LED on both the sensor and the controller are on and all other LEDs are off.

Alarm State

The smoke detector enters the alarm state when the amount of smoke particulate in the sensor's sensing chamber exceeds the alarm threshold value. (See Table 3.) Upon entering the alarm state:

- The sensor's Alarm LED and the controller's Alarm LED turn on.
- The contacts on the controller's two auxiliary relays switch positions.
- The contacts on the controller's alarm initiation relay close.
- The controller's remote alarm LED output is activated (turned on).
- The controller's high impedance multiple fan shutdown control line is pulled to ground Trouble state.

The SuperDuct duct smoke detector enters the trouble state under the following conditions:

- A sensor's cover is removed and 20 minutes pass before it is properly secured.
- A sensor's environmental compensation limit is reached (100% dirty).
- A wiring fault between a sensor and the controller is detected.

An internal sensor fault is detected upon entering the trouble state:

- The contacts on the controller's supervisory relay switch positions. (See Fig. 21.)
- If a sensor trouble, the sensor's Trouble LED the controller's Trouble LED turn on.
- If 100% dirty, the sensor's Dirty LED turns on and the controller's Trouble LED flashes continuously.
- If a wiring fault between a sensor and the controller, the

controller's Trouble LED turns on but not the sensor's.

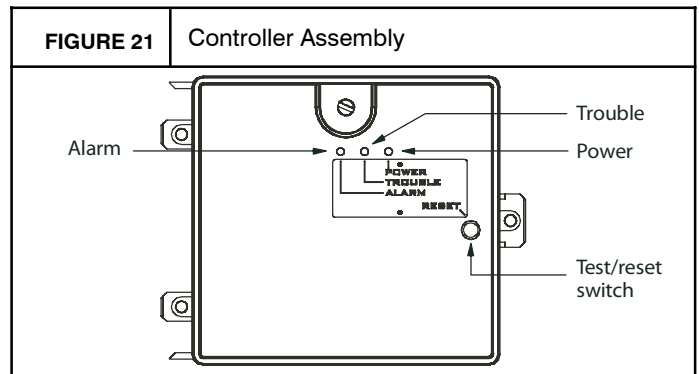

NOTE: All troubles are latched by the duct smoke detector. The trouble condition must be cleared and then the duct smoke detector must be reset in order to restore it to the normal state.

Resetting Alarm and Trouble Condition Trips:

Manual reset is required to restore smoke detector systems to Normal operation. For installations using two sensors, the duct smoke detector does not differentiate which sensor signals an alarm or trouble condition. Check each sensor for Alarm or Trouble status (indicated by LED). Clear the condition that has generated the trip at this sensor. Then reset the sensor by pressing and holding the reset button (on the side) for 2 seconds. Verify that the sensor's Alarm and Trouble LEDs are now off. At the controller, clear its Alarm or Trouble state by pressing and holding the manual reset button (on the front cover) for 2 seconds. Verify that the controller's Alarm and Trouble LEDs are now off. Replace all panels.

Troubleshooting

Controller's Trouble LED is On

- Check the Trouble LED on each sensor connected to the controller. If a sensor's Trouble LED is on, determine the cause and make the necessary repairs.
- Check the wiring between the sensor and the controller. If wiring is loose or missing, repair or replace as required.

Controller's Trouble LED is Flashing

- One or both of the sensors is 100% dirty.
- Determine which Dirty LED is flashing then clean that sensor assembly as described in the detector cleaning section.

Sensor's Trouble LED is On

- Check the sensor's Dirty LED. If it is flashing, the sensor is dirty and must be cleaned.
- Check the sensor's cover. If it is loose or missing, secure the cover to the sensor housing.
- Replace sensor assembly.

Sensor's Power LED is Off

- Check the controller's Power LED. If it is off, determine why the controller does not have power and make the necessary repairs.
- Check the wiring between the sensor and the controller. If wiring is loose or missing, repair or replace as required.

Controller's Power LED is Off

- Make sure the circuit supplying power to the controller is operational. If not, make sure JP2 and JP3 are set correctly on the controller before applying power.

- Verify that power is applied to the controller's supply input terminals. If power is not present, replace or repair wiring as required.

Remote Test/Reset Station's Trouble LED Does Not flash When Performing a Dirty Test, But the Controller's Trouble LED Does

- Verify that the remote test/station is wired as shown in Fig. 23. Repair or replace loose or missing wiring.
- Configure the sensor dirty test to activate the controller's supervision relay. See "Changing sensor dirty test operation."

Sensor's Trouble LED is On, But the Controller's Trouble LED is OFF

Remove JP1 on the controller.

PROTECTIVE DEVICES

Compressor Protection

Overcurrent

The compressor has internal linebreak motor protection.

Overtemperature

The compressor has an internal protector to protect it against excessively high discharge gas temperatures.

High Pressure Switch

The system is provided with a high pressure switch mounted on the discharge line. The switch is stem-mounted and brazed into the discharge tube. Trip setting is 630 psig +/- 10 psig (4344 +/- 69 kPa) when hot. Reset is automatic at 505 psig (3482 kPa).

Low Pressure Switch

The system is protected against a loss of charge and low evaporator coil loading condition by a low pressure switch located on the suction line near the compressor. The switch is stem-mounted. Trip setting is 54 psig +/- 5 psig (372 +/- 34 kPa). Reset is automatic at 117 +/- 5 psig (807 +/- 34 kPa).

Evaporator Freeze Protection

The system is protected against evaporator coil frosting and low temperature conditions by a temperature switch mounted on the evaporator coil hairpin. Trip setting is 30°F +/- 5°F (-1°C +/- 3°C). Reset is automatic at 45°F (7°C).

Supply (Indoor) Fan Motor Protection

Disconnect and lockout power when servicing fan motor.

The standard supply fan motor is equipped with internal overcurrent and overtemperature protection. Protection devices reset automatically.

The High Static option supply fan motor is equipped with a pilot-circuit Thermix combination overtemperature/overcurrent protection device. This device resets automatically. Do not bypass this switch to correct trouble. Determine the cause and correct it.

Condenser Fan Motor Protection

The condenser fan motor is internally protected against overtemperature.

Relief Device

A soft solder joint at the suction service access port provides pressure relief under abnormal temperature and pressure conditions (i.e., fire in building). Protect this joint during brazing operations near this joint.

Control Circuit, 24-V

The control circuit is protected against overcurrent conditions by a circuit breaker mounted on control transformer TRAN. Reset is manual.

GAS HEATING SYSTEM

RGS unit heating systems are referenced here according to unit Gas Heat Option (defined in the unit model number Position#8). See Appendix 1 for a complete unit model number nomenclature chart.

POSITION #8	GAS HEAT OPTION
D, E, F / S, R, T	Nat. Gas / SS Heat Xgr & Std Heat
L, M, N	Nat. Gas / SS HX and Low NO _x Heat

General

The heat exchanger system consists of a gas valve feeding multiple inshot burners off a manifold. The burners fire into matching primary tubes. The primary tubes discharge into combustion plenum where gas flow converges into secondary tubes. The secondary tubes exit into the induced draft fan wheel inlet. The induced fan wheel discharges into a flue passage and flue gases exit out a flue hood on the side of the unit. The induced draft fan motor includes a Hall Effect sensor circuit that confirms adequate wheel speed via the Integrated Gas Control (IGC) board. Safety switches include a Rollout Switch (at the top of the burner compartment) and a limit switch (mounted through the fan deck, over the tubes). (See Fig. 22 and Fig. 23.)

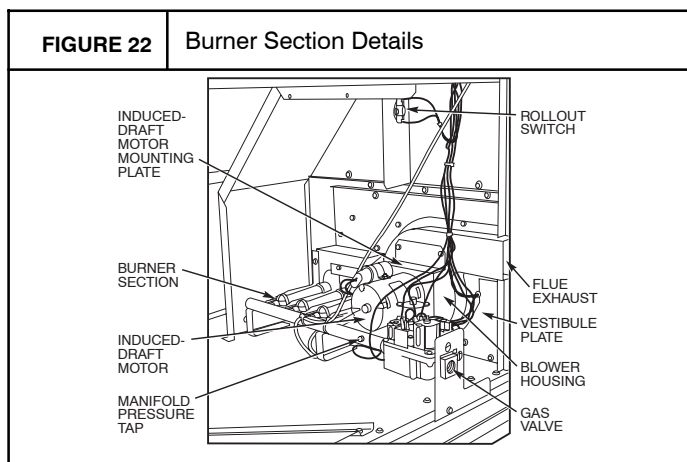

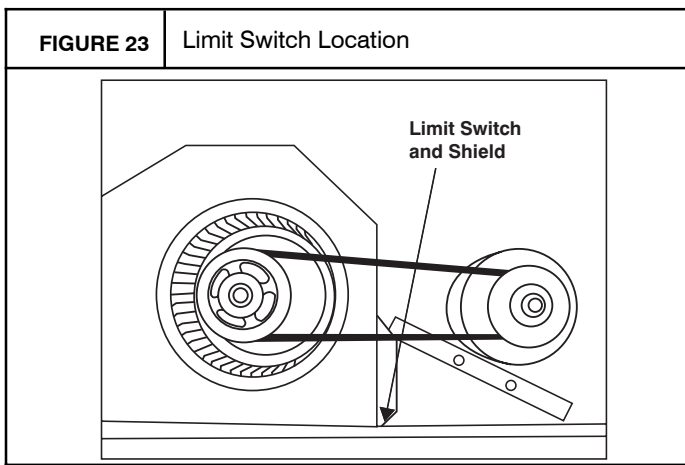

Fuel Types and Pressures

Natural Gas — The RGS unit is factory-equipped for use with Natural Gas fuel at elevation under 2000 ft (610 m). See section Orifice Replacement for information in modifying this unit for installation at elevations above 2000 ft (610 m).

Gas line pressure entering the unit’s main gas valve must be within specified ranges. Adjust unit gas regulator valve as required or consult local gas utility.

Table 4 – Natural Gas Supply Line Pressure Ranges

RGS SIZE	GAS HEAT OPT	HEAT LEVEL	MIN	MAX
All	All	All	4.0 in. wg (996 Pa)	13.0 in. wg (3240 Pa)

Manifold pressure is factory-adjusted for NG fuel use. Adjust as required to obtain best flame characteristic.

Table 5 – Natural Gas Manifold Pressure Ranges

GAS HEAT OPT	HEAT LEVEL	HIGH FIRE	LOW FIRE	RANGE
D, E, F /S, R, T	All	3.5 in. wg (872 Pa)	1.7 in. wg (423 Pa)†	2.0–5.0 in. wg (Hi) (498–1245 Pa)
L, M, N	All	3.5 in. wg (872 Pa)	NA	2.0–5.0 in. wg (Hi) (498–1245 Pa)

NA: Not Available
† 3 Phase models only

Liquid Propane — Accessory packages are available for field-installation that will convert the RGS unit (except low NO_x model) to operate with Liquid Propane (LP) fuels. These kits include new orifice spuds, new springs for gas valves and a supply line low pressure switch. See section on Orifice Replacement for details on orifice size selections.

Low NO_x models include specially-sized orifices and use of different flue flow limits and tube baffles. Because of these extra features, conversion of these models to LP is not recommended.

Fuel line pressure entering unit gas valve must remain within specified range.

Table 6 – Liquid Propane Supply Line Pressure Ranges

RGS SIZE	GAS HEAT OPT	HEAT LEVEL	MIN	MAX
All	S, R, T	All	11.0 in. wg (2740 Pa)	13.0 in. wg (3240 Pa)
All	L, M, N	All	NA	NA

Manifold pressure for LP fuel use must be adjusted to specified range. Follow instructions in the accessory kit to make initial readjustment.

Table 7 – Liquid Propane Manifold Pressure Ranges

GAS HEAT OPT	HEAT LEVEL	HIGH FIRE	LOW FIRE
D, E, F /S, R, T	All	10.0 in. wg (2490 Pa)	5.0 in. wg (1245 Pa)†
L, M, N	All	NA	NA

NA: Not Available
† 3 Phase models only

Supply Pressure Switch — The LP conversion kit includes a supply low pressure switch. The switch contacts (from terminal C to terminal NO) will open the gas valve power whenever the supply line pressure drops below the setpoint. See Fig. 29 and Fig. 30. If the low pressure remains open for 15 minutes during a call for heat, the IGC circuit will initiate a Ignition Fault (5 flashes) lockout. Reset of the low pressure switch is automatic on rise in supply line pressure. Reset of the IGC requires a recycle of unit power after the low pressure switch has closed.

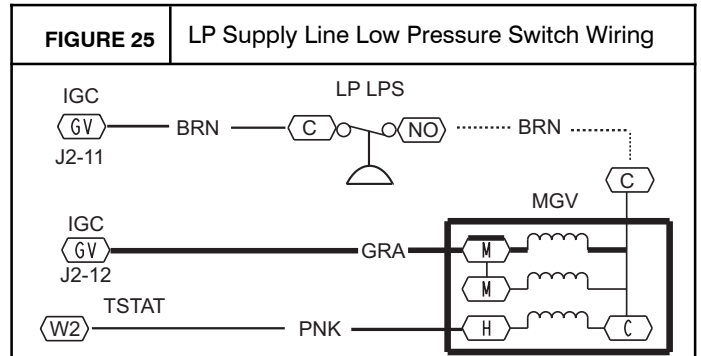
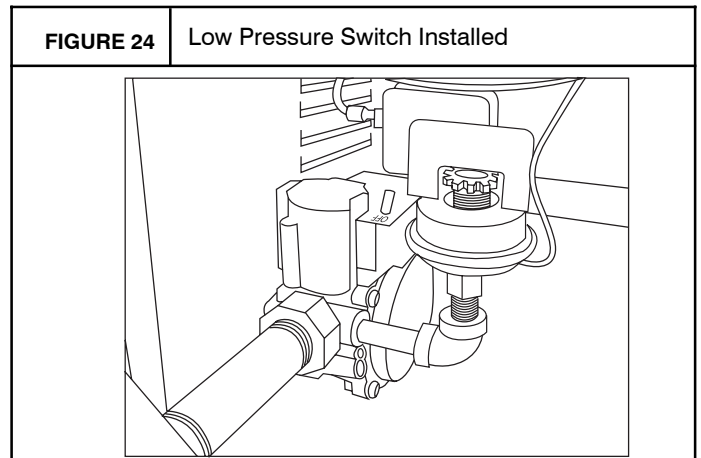

This switch also prevents operation when the propane tank level is low which can result in gas with a high concentration of impurities, additives, and residues that have settled to the bottom of the tank. Operation under these conditions can cause harm to the heat exchanger system. Contact your fuel supplier if this condition is suspected.

Flue Gas Passageways

To inspect the flue collector box and upper areas of the heat exchanger:

1. Remove the combustion blower wheel and motor assembly according to directions in Combustion-Air Blower section. See Fig. 26.
2. Remove the flue cover to inspect the heat exchanger.
3. Clean all surfaces as required using a wire brush.

Combustion-Air Blower

Clean periodically to assure proper airflow and heating efficiency. Inspect blower wheel every fall and periodically during heating season. For the first heating season, inspect blower wheel bi-monthly to determine proper cleaning frequency.

To access burner section, slide the sliding burner partition out of the unit.

To inspect blower wheel, shine a flashlight into draft hood opening. If cleaning is required, remove motor and wheel as follows:

1. Slide burner access panel out.
2. Remove the 7 screws that attach induced-draft motor housing to vestibule plate. (See Fig. 26.)
3. The blower wheel can be cleaned at this point. If additional cleaning is required, continue with Steps 4 and 5.
4. To remove blower from the motor shaft, remove 2 setscrews.
5. To remove motor, remove the 4 screws that hold the motor to mounting plate. Remove the motor cooling fan by removing one setscrew. Then remove nuts that hold motor to mounting plate.
6. To reinstall, reverse the procedure outlined above.

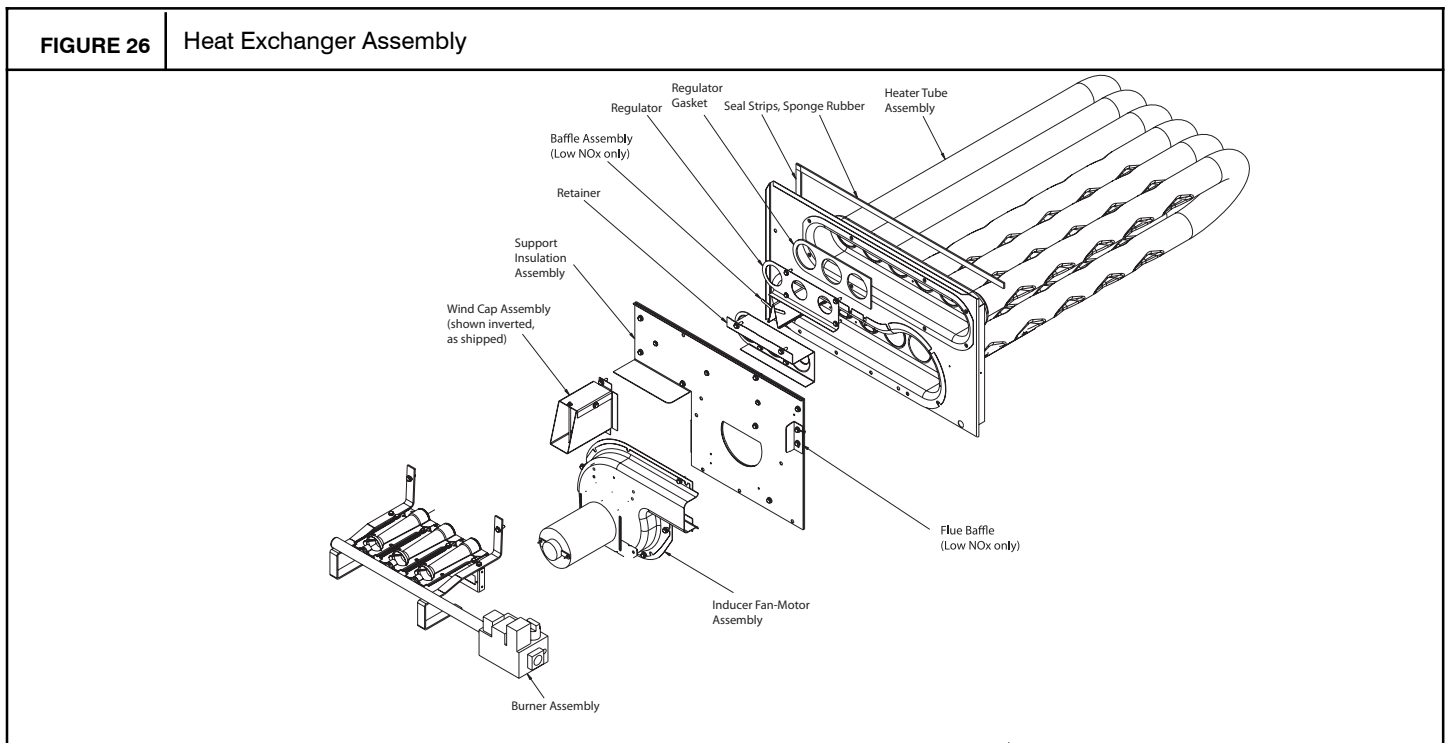

Burners and Igniters

⚠ CAUTION

EQUIPMENT DAMAGE HAZARD

Failure to follow this caution may result in equipment damage.

When working on gas train, do not hit or plug orifice spuds.

Main Burners

To access burners, remove burner access panel and slide out burner partition. At the beginning of each heating season,

inspect for deterioration or blockage due to corrosion or other causes. Observe the main burner flames and adjust, if necessary.

Orifice projection — Refer to Fig. 27 for maximum projection dimension for orifice face to manifold tube.

Removal and Replacement of Gas Train

See Fig. 22, Fig. 26 and Fig. 28.

1. Shut off manual gas valve.
2. Shut off power to unit.
3. Slide out burner partition.
4. Disconnect gas piping at unit gas valve.

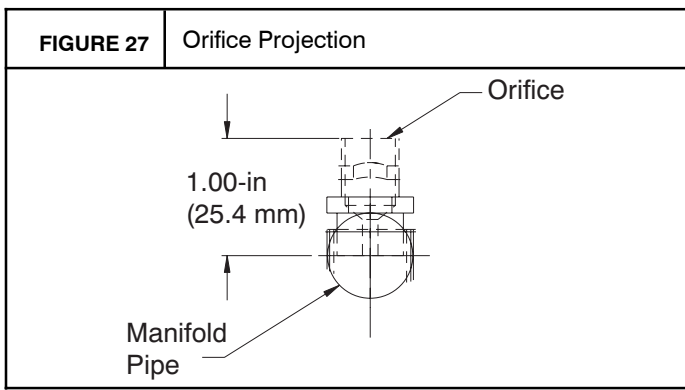

5. Remove wires connected to gas valve. Mark each wire.
6. Remove igniter wires and sensor wires at the Integrated Gas Unit Controller (IGC). (See Fig. 29.)
7. Remove the 2 screws that attach the burner rack to the vestibule plate (Fig. 22).
8. Slide the burner tray out of the unit (Fig. 28).
9. To reinstall, reverse the procedure outlined above.

Cleaning and Adjustment

1. Remove burner rack from unit as described in Removal and Replacement of Gas Train section, above.
2. Inspect burners; if dirty, remove burners from rack. (Mark each burner to identify its position before removing from the rack.)
3. Use a soft brush to clean burners and cross-over port as required.
4. Adjust spark gap. See Fig. 30 and Fig. 31.
5. If factory orifice has been removed, check that each orifice is tight at its threads into the manifold pipe and that orifice projection does not exceed maximum valve. See Fig. 27
6. Reinstall burners on rack in the same locations as factory-installed. (The outside crossover flame regions of the outermost burners are pinched off to prevent excessive gas flow from the side of the burner assembly. If the pinched crossovers are installed between two burners, the flame will not ignite properly.)

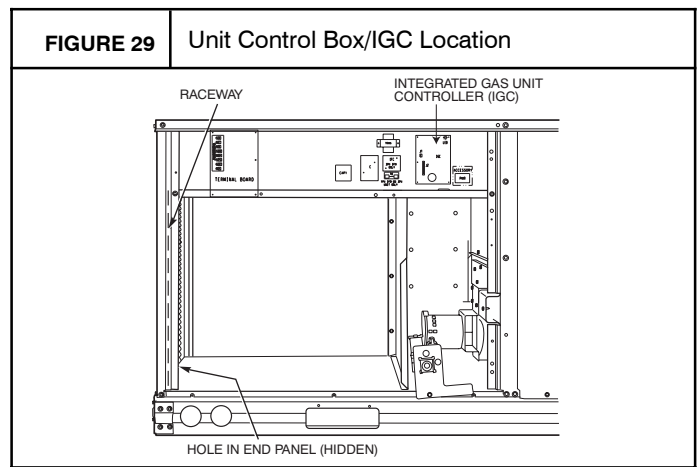
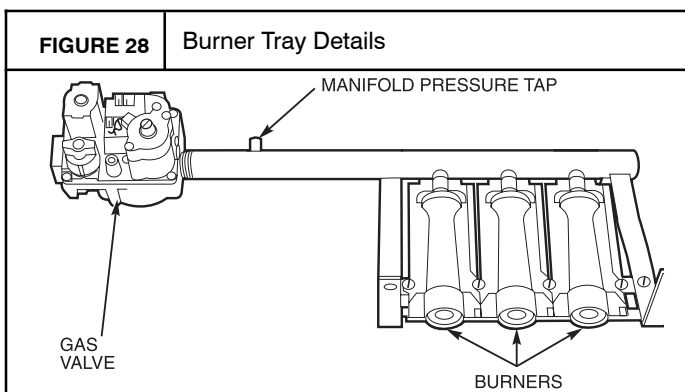

7. Reinstall burner rack as described in Removal and Replacement of Gas Train section, above.

Gas Valve — All three-phase models (except Low NO_x) are equipped with 2-stage gas valves. Single-phase models and all Low NO_x models are equipped with single-stage gas valves. See Fig. 37 for locations of adjustment screws and features on the gas valves.

To adjust gas valve pressure settings:

IMPORTANT: Leak check all gas connections including the main service connection, gas valve, gas spuds, and manifold pipe plug. All leaks must be repaired before firing unit.

Check Unit Operation and Make Necessary Adjustments

NOTE: Gas supply pressure at gas valve inlet must be within specified ranges for fuel type and unit size. See Tables 4 and 5.

1. Remove manifold pressure tap plug from manifold and connect pressure gauge or manometer. (See Fig. 28)
2. Turn on electrical supply.
3. Turn on unit main gas valve.
4. Set room thermostat to call for heat. If unit has two-stage gas valve, verify high-stage heat operation before attempting to adjust manifold pressure.
5. When main burners ignite, check all fittings, manifold, and orifices for leaks.
6. Adjust high-stage pressure to specified setting by turning the plastic adjustment screw clockwise to increase pressure, counter-clockwise to decrease pressure.
7. **For Two-Stage Gas Valves** set room thermostat to call for low-stage heat. Adjust low-stage pressure to specified setting.
8. Replace regulator cover screw(s) when finished.
9. With burner access panel removed, observe unit heating operation in both high stage and low stage operation if so equipped. Observe burner flames to see if they are blue in appearance, and that the flames are approximately the same for each burner.
10. Turn off unit, remove pressure manometer and replace the 1/8 in. pipe fitting on the gas manifold. See Fig. 28.

Limit Switch

Remove blower access panel. Limit switch is located on the fan deck. See Fig. 23.

Burner Ignition

Unit is equipped with a direct spark ignition 100% lockout system. Integrated Gas Unit Controller (IGC) is located in the control box. See Fig. 29. The IGC contains a self-diagnostic LED (light-emitting diode). A single LED (see Fig. 33) on the IGC provides a visual display of operational or sequential problems when the power supply is uninterrupted. When a break in power occurs, the IGC will be reset (resulting in a loss

of fault history) and the indoor (evaporator) fan ON/OFF times will be reset. The LED error code can be observed through the viewport. During servicing refer to the label on the control box cover or Table 8 for an explanation of LED error code descriptions.

If lockout occurs, unit may be reset by interrupting power supply to unit for at least 5 seconds.

FIGURE 30 Spark Adjustment, Size 036 – 072

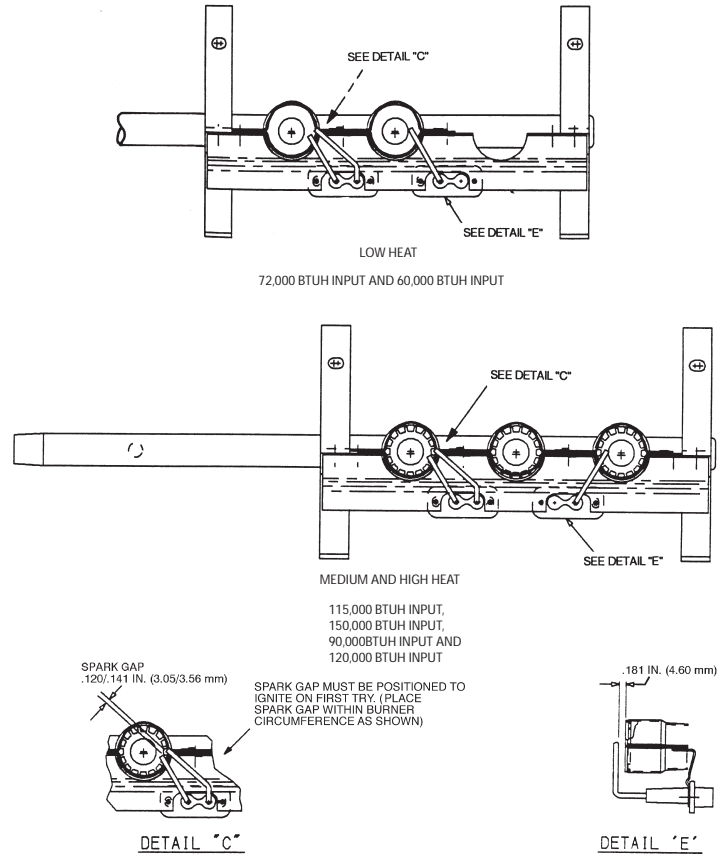

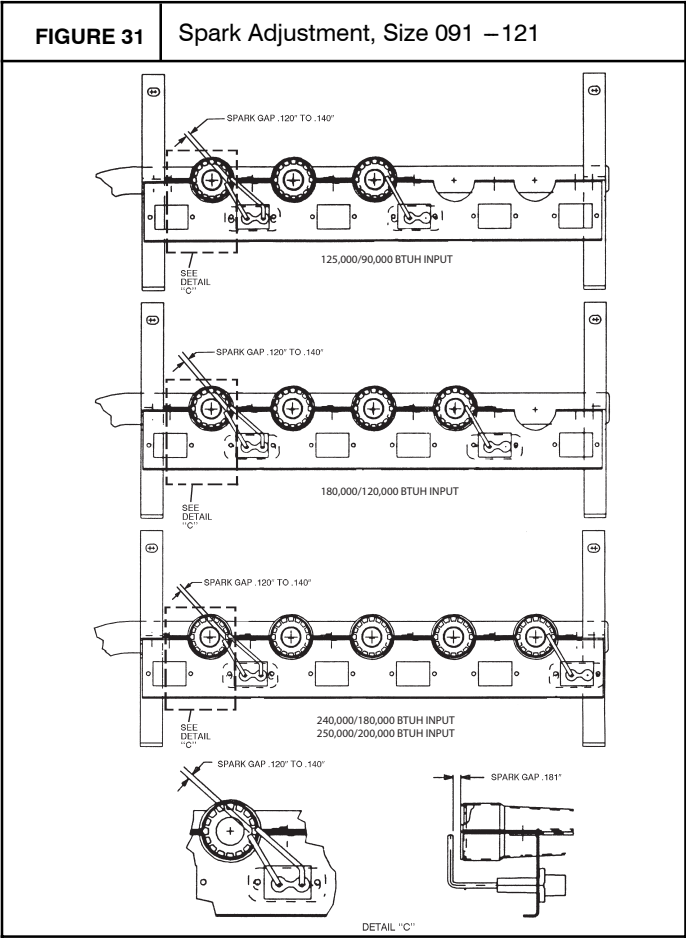

Table 8 – LED Error Code Description*

LED INDICATION	ERROR CODE DESCRIPTION
ON	Normal Operation
OFF	Hardware Failure
1 Flash†	Evaporator Fan On/Off Delay Modified
2 Flashes	Limit Switch Fault
3 Flashes	Flame Sense Fault
4 Flashes	4 Consecutive Limit Switch Faults
5 Flashes	Ignition Lockout Fault
6 Flashes	Induced-Draft Motor Fault
7 Flashes	Rollout Switch Fault
8 Flashes	Internal Control Fault
9 Flashes	Software Lockout

LEGEND

LED – Light Emitting Diode

* A 3-second pause exists between LED error code flashes. If more than one error code exists, all applicable codes will be displayed in numerical sequence.

† Indicates a code that is not an error. The unit will continue to operate when this code is displayed.

IMPORTANT: Refer to Troubleshooting Table 13 and Table 14 for additional information.

Orifice Replacement

This unit uses orifice type LH32RFnnn (where nnn indicates orifice reference size). When replacing unit orifices, order the necessary parts via Fast Parts. See Table 10 for available orifice sizes. See Table 11 and Table 12 for orifice sizes for Natural Gas and LP fuel usage at various elevations above sea level.

Check that each replacement orifice is tight at its threads into the manifold pipe and that orifice projection does not exceed maximum value. See Fig. 27.

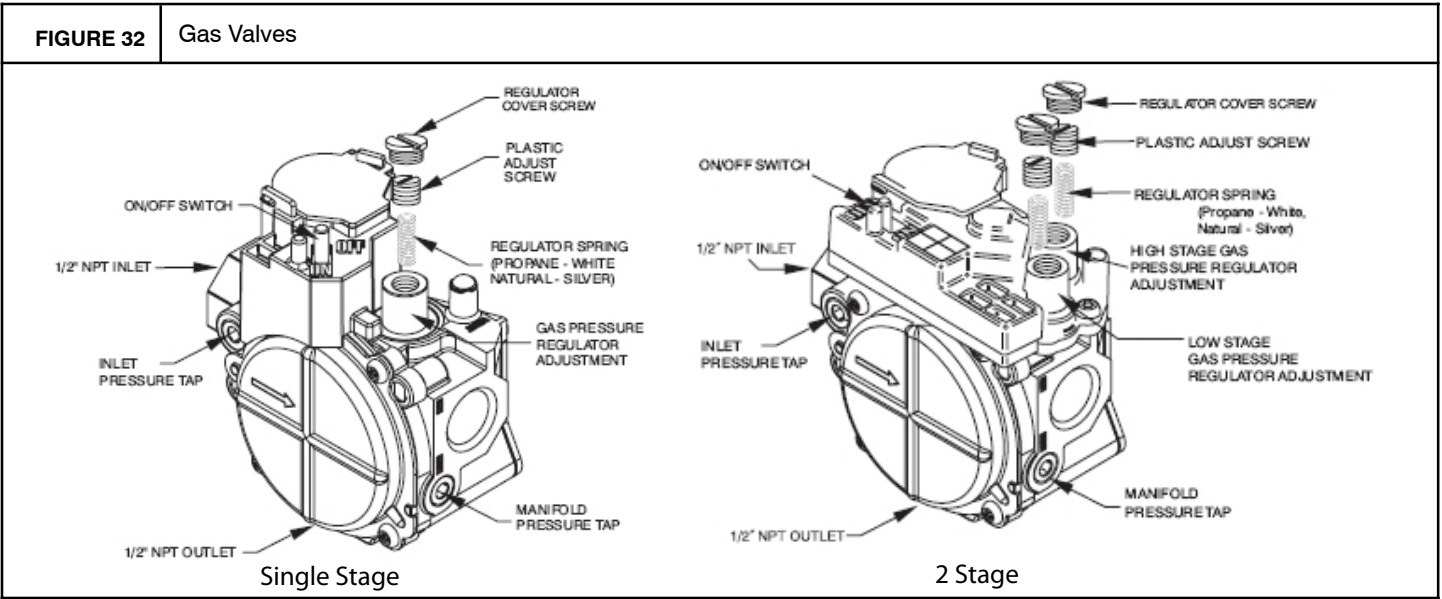

FIGURE 33

Integrated Gas Control (IGC) Board

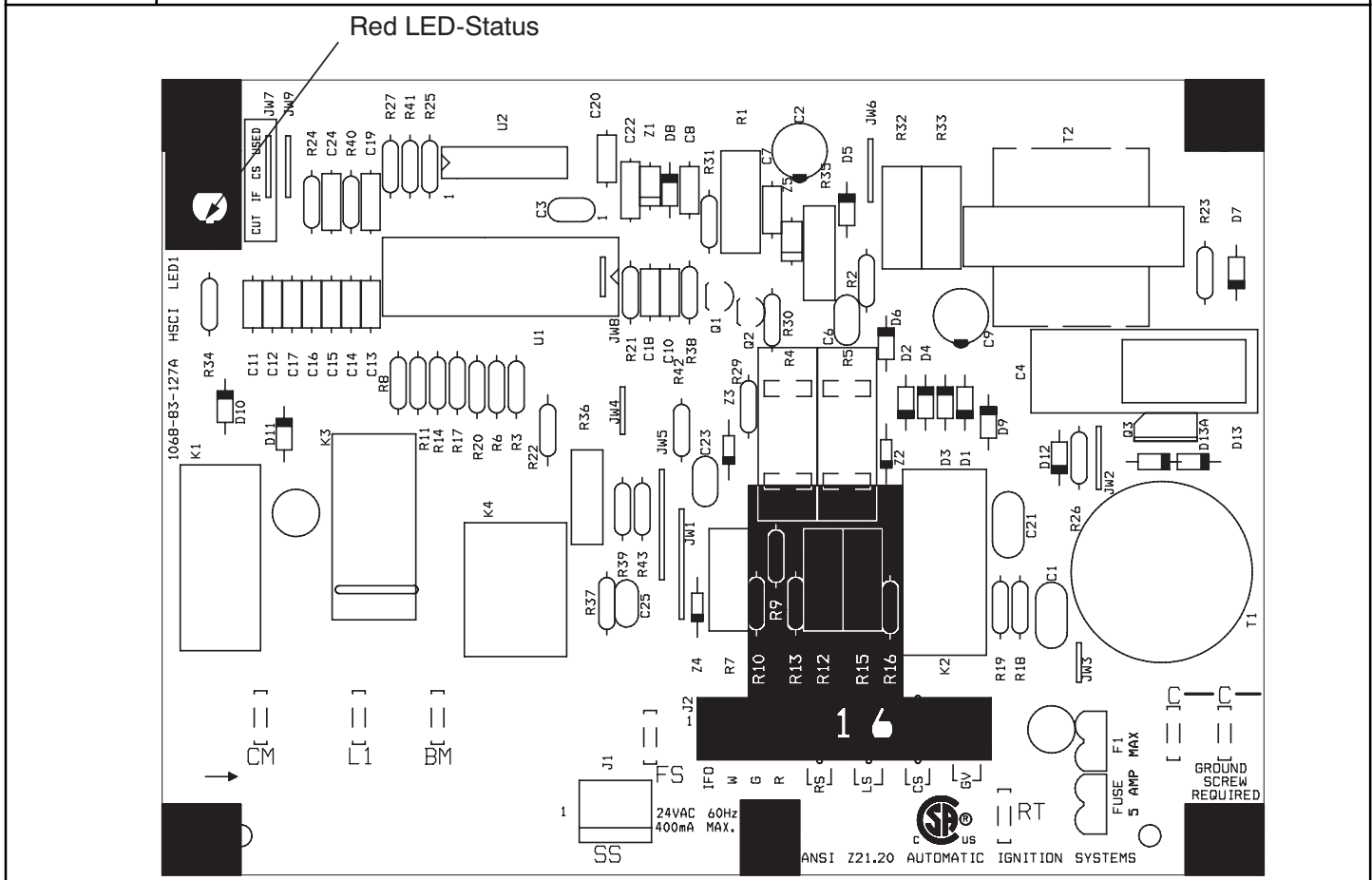

Table 9 – IGC Connections

TERMINAL LABEL	POINT DESCRIPTION	SENSOR LOCATION	TYPE OF I/O	CONNECTION PIN NUMBER
INPUTS				
RT, C	Input power from TRAN 1	control box	24 VAC	—
SS	Speed sensor	gas section	analog input	J1, 1-3
FS, T1	Flame sensor	gas section	switch input	—
W	Heat stage 1	LCTB	24 VAC	J2, 2
RS	Rollout switch	gas section	switch input	J2, 5-6
LS	Limit switch	fan section	switch input	J2, 7-8
CS	Centrifugal switch (not used)	—	switch input	J2, 9-10
OUTPUTS				
L1, CM	Induced draft combustion motor	gas section	line VAC	
IFO	Indoor fan	control box	relay	J2, 1
GV	Gas valve (heat stage 1)	gas section	relay	J2, 11-12

Table 10 – Orifice Sizes

ORIFICE DRILL SIZE	PART NUMBER	DRILL DIA. (in.)
#30	LH32RF129	0.1285
1/8	LH32RF125	0.1250
#31	LH32RF120	0.1200
#32	LH32RF116	0.1160
#33	LH32RF113	0.1130
#34	LH32RF111	0.1110
#35	LH32RF110	0.1100
#36	LH32RF105	0.1065
#37	LH32RF104	0.1040
#38	LH32RF102	0.1015
#39	LH32RF103	0.0995
#40	LH32RF098	0.0980
#41	LH32RF096	0.0960
#42	LH32RF094	0.0935
#43	LH32RF089	0.0890
#44	LH32RF086	0.0860
#45	LH32RF082	0.0820
#46	LH32RF080	0.0810
#47	LH32RF079	0.0785
#48	LH32RF076	0.0760
#49	LH32RF073	0.0730
#50	LH32RF070	0.0700
#51	LH32RF067	0.0670
#52	LH32RF065	0.0635
#53	LH32RF060	0.0595
#54	LH32RF055	0.0550
#55	LH32RF052	0.0520
#56	LH32RF047	0.0465
#57	LH32RF043	0.0430
#58	LH32RF042	0.0420

Table 11 – Altitude Compensation* (036-072) - Small Chassis

ELEVATION ft (m)	72,000 BTUH Nominal		115,000 BTUH Nominal		150,000 BTUH Nominal	
	NG Orifice Size	LP Orifice Size	NG Orifice Size	LP Orifice Size	NG Orifice Size	LP Orifice Size
0 – 2000 (610)	33 ¹	51 ⁴	33 ¹	50 ³	†30	46 ³
2000 (610)	35 ¹	51 ⁴	35 ¹	51 ⁴	†30	47 ³
3000 (914)	35 ¹	52 ⁴	35 ¹	51 ⁴	31 ¹	47 ³
4000 (1219)	36 ¹	52 ⁴	36 ¹	51 ⁴	31 ¹	48 ³
5000 (1524)	36 ¹	52 ⁴	36 ¹	51 ⁴	31 ¹	48 ³
6000 (1829)	37 ²	52 ⁴	37 ²	52 ⁴	31 ¹	48 ³
7000 (2134)	38 ²	53 ⁴	38 ²	52 ⁴	32 ¹	49 ³
8000 (2438)	39 ²	53 ⁴	39 ²	52 ⁴	33 ¹	49 ³
9000 (2743)	†40	53 ⁴	†40	53 ⁴	34 ¹	50 ³
10000 (3048)	†41	54 ⁴	†41	53 ⁴	35 ¹	50 ³
11000 (3353)	†42	54 ⁴	†42	53 ⁴	36 ¹	51 ⁴
12000 (3658)	†43	54 ⁴	†43	54 ⁴	37 ²	51 ⁴
13000 (3962)	†43	55 ⁴	†43	54 ⁴	38 ²	52 ⁴
14000 (4267)	44 ²	†56	44 ²	55 ⁴	†40	53 ⁴

Table 11 (cont.) - Altitude Compensation* (091-121)

ELEVATION ft (m)	125,000 BTUH Nominal		250,000 BTUH Nominal		180,000, 224,000 BTUH Nominal	
	NG Orifice Size	LP Orifice Size	NG Orifice Size	LP Orifice Size	NG Orifice Size	LP Orifice Size
0 – 2000 (610)	31 ¹	49 ³	†30	46 ³	31 ¹	48 ³
2000 (610)	32 ¹	50 ³	†30	47 ³	32 ¹	49 ³
3000 (914)	32 ¹	50 ³	31 ¹	47 ³	32 ¹	49 ³
4000 (1219)	33 ¹	50 ³	31 ¹	48 ³	33 ¹	49 ³
5000 (1524)	33 ¹	51 ⁴	31 ¹	48 ³	33 ¹	50 ³
6000 (1829)	34 ¹	51 ⁴	31 ¹	48 ³	34 ¹	50 ³
7000 (2134)	35 ¹	51 ⁴	32 ¹	49 ³	35 ¹	50 ³
8000 (2438)	36 ¹	52 ⁴	33 ¹	49 ³	36 ¹	51 ⁴
9000 (2743)	37 ²	52 ⁴	34 ¹	50 ³	37 ²	51 ⁴
10000 (3048)	38 ²	52 ⁴	35 ¹	50 ³	38 ²	52 ⁴
11000 (3353)	39 ²	53 ⁴	36 ¹	51 ⁴	39 ²	52 ⁴
12000 (3658)	†41	53 ⁴	37 ²	51 ⁴	†41	53 ⁴
13000 (3962)	†42	54 ⁴	38 ²	52 ⁴	†42	53 ⁴
14000 (4267)	†43	54 ⁴	†40	53 ⁴	†43	54 ⁴

Table 12 – Altitude Compensation* (036-060) - Low NO_x Units

ELEVATION ft (m)	60,000, 90,000 BTUH Nominal		120,000 BTUH Nominal	
	NG Orifice Size	LP Orifice Size	NG Orifice Size	LP Orifice Size
0 – 2000 (610)	38 ²	53 ⁴	32 ¹	50 ³
2000 (610)	39 ²	54 ⁴	33 ¹	51 ⁴
3000 (914)	†40	54 ⁴	34 ¹	51 ⁴
4000 (1219)	†41	54 ⁴	35 ¹	51 ⁴
5000 (1524)	†41	54 ⁴	35 ¹	51 ⁴
6000 (1829)	†42	54 ⁴	36 ¹	52 ⁴
7000 (2134)	†42	54 ⁴	36 ¹	52 ⁴
8000 (2438)	†43	55 ⁴	37 ²	52 ⁴
9000 (2743)	†43	55 ⁴	38 ²	53 ⁴
10000 (3048)	44 ²	55 ⁴	†40	53 ⁴
11000 (3353)	44 ²	55 ⁴	†41	53 ⁴
12000 (3658)	45 ²	†56	†42	54 ⁴
13000 (3962)	47 ³	†56	†43	54 ⁴
14000 (4267)	48 ³	†56	†43	55 ⁴

LEGEND:

NG = Natural Gas LP = Liquid Propane

* As the height above sea level increases, there is less oxygen per cubic ft. of air. Therefore, heat input rate should be reduced at higher altitudes.

† Not included in kit. May be purchased separately through dealer.

- 1 = CRLPELEV001A00
- 2 = CRLPELEV002A00
- 3 = CRLPELEV003A00
- 4 = CRLPELEV004A00

Minimum heating entering air temperature

When operating on first stage heating, the minimum temperature of air entering the dimpled heat exchanger is 50°F continuous and 45°F intermittent for standard heat exchangers and 40°F continuous and 35°F intermittent for stainless steel heat exchangers. To operate at lower mixed-air temperatures, a field-supplied outdoor-air thermostat must be used to initiate both stages of heat when the temperature is below the minimum required temperature to ensure full fire operation. Wire the outdoor-air thermostat (part no. HH22AG106) in series with the second stage gas valve as shown below. Set the outdoor-air thermostat at 35°F for stainless steel heat exchangers or 45°F for standard heat exchangers. This temperature setting will bring on the second stage of heat whenever the ambient temperature is below the thermostat setpoint. Indoor comfort may be compromised when heating is initiated using low

entering air temperatures with insufficient heating temperature rise.

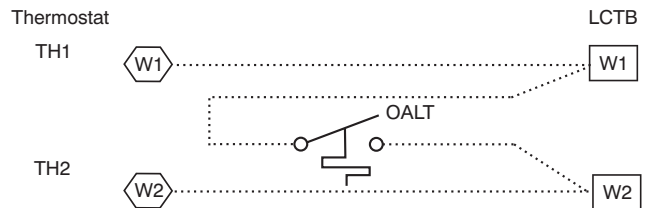

Troubleshooting Heating System

Refer to Table 13 and Table 14 for additional troubleshooting topics.

Table 13 – Heating Service Analysis

PROBLEM	CAUSE	REMEDY
Burners Will Not Ignite.	Misaligned spark electrodes.	Check flame ignition and sensor electrode positioning. Adjust as needed.
	No gas at main burners.	Check gas line for air, purge as necessary. After purging gas line of air, allow gas to dissipate for at least 5 minutes before attempting to relight unit. Check gas valve.
	Water in gas line.	Drain water and install drip leg to trap water.
	No power to furnace.	Check power supply, fuses, wiring, and circuit breaker.
	No 24 v power supply to control circuit.	Check transformer. Transformers with internal overcurrent protection require a cool down period before resetting.
	Miswired or loose connections.	Check all wiring and wire nut connections.
	Burned-out heat anticipator in thermostat.	Replace thermostat.
Inadequate Heating.	Broken thermostat wires.	Run continuity check. Replace wires, if necessary.
	Dirty air filter.	Clean or replace filter as necessary.
	Gas input to unit too low.	Check gas pressure at manifold. Clock gas meter for input. If too low, increase manifold pressure, or replace with correct orifices.
	Unit undersized for application.	Replace with proper unit or add additional unit.
	Restricted airflow.	Clean filter, replace filter, or remove any restrictions.
	Blower speed too low.	Use high speed tap, increase fan speed, or install optional blower, as suitable for individual units.
	Limit switch cycles main burners.	Check rotation of blower, thermostat heat anticipator settings, and temperature rise of unit. Adjust as needed.
Poor Flame Characteristics.	Incomplete combustion (lack of combustion air) results in: Aldehyde odors, CO, sooting flame, or floating flame.	Adjust minimum position.
		Check economizer operation.
		Check all screws around flue outlets and burner compartment. Tighten as necessary.
		Cracked heat exchanger.
Burners Will Not Turn Off.	Unit is locked into Heating mode for a one minute minimum.	Overfired unit — reduce input, change orifices, or adjust gas line or manifold pressure.
		Check vent for restriction. Clean as necessary.
		Check orifice to burner alignment.
		Wait until mandatory one-minute time period has elapsed or reset power to unit.

Table 14 – IGC Board LED Alarm Codes

LED FLASH CODE	DESCRIPTION	ACTION TAKEN BY CONTROL	RESET METHOD	PROBABLE CAUSE
On	Normal Operation	—	—	—
Off	Hardware Failure	No gas heating.	—	Loss of power to the IGC. Check 5 amp fuse on IGC, power to unit, 24V circuit breaker, transformer, and wiring to the IGC.
2 Flashes	Limit Switch Fault	Gas valve and igniter Off. Indoor fan and inducer On.	Limit switch closed, or heat call (W) Off.	High temperature limit switch is open. Check the operation of the indoor (evaporator) fan motor. Ensure that the supply-air temperature rise is within the range on the unit nameplate. Check wiring and limit switch operation.
3 Flashes	Flame Sense Fault	Indoor fan and inducer On.	Flame sense normal. Power reset for LED reset.	The IGC sensed a flame when the gas valve should be closed. Check wiring, flame sensor, and gas valve operation.
4 Flashes	Four Consecutive Limit Switch Fault	No gas heating.	Heat call (W) Off. Power reset for LED reset.	4 consecutive limit switch faults within a single call for heat. See Limit Switch Fault.
5 Flashes	Ignition Fault	No gas heating.	Heat call (W) Off. Power reset for LED reset.	Unit unsuccessfully attempted ignition for 15 minutes. Check igniter and flame sensor electrode spacing, gaps, etc. Check flame sense and igniter wiring. Check gas valve operation and gas supply. Check gas valve connections to IGC terminals. BRN lead must be on Pin 11.
6 Flashes	Induced Draft Motor Fault	If heat off: no gas heating. If heat on: gas valve Off and inducer On.	Inducer sense normal, or heat call (W) Off.	Inducer sense On when heat call Off, or inducer sense Off when heat call On. Check wiring, voltage, and operation of IGC motor. Check speed sensor wiring to IGC.
7 Flashes	Rollout Switch Lockout	Gas valve and igniter Off. Indoor fan and inducer On.	Power reset.	Rollout switch has opened. Check gas valve operation. Check induced-draft blower wheel is properly secured to motor shaft.
8 Flashes	Internal Control Lockout	No gas heating.	Power reset.	IGC has sensed internal hardware or software error. If fault is not cleared by resetting 24 v power, replace the IGC.
9 Flashes	Temporary Software Lockout	No gas heating.	1 hour auto reset, or power reset.	Electrical interference is disrupting the IGC software.

LEGEND

IGC – Integrated Gas Unit Control

LED – Light–Emitting Diode

NOTES:

1. There is a 3–second pause between alarm code displays.
1. If more than one alarm code exists, all applicable alarm codes will be displayed in numerical sequence.
1. Alarm codes on the IGC will be lost if power to the unit is interrupted.

ECONOMIZER SYSTEMS (OPTIONAL)

The RGS units may be equipped with a factory-installed or accessory (field-installed) economizer system. A logic control system (EconoMi\$er IV uses a Honeywell W7212A Controller). See Fig. 34 for component locations. See Fig. 35 economizer section wiring diagrams.

Economizers use direct-drive damper actuators.

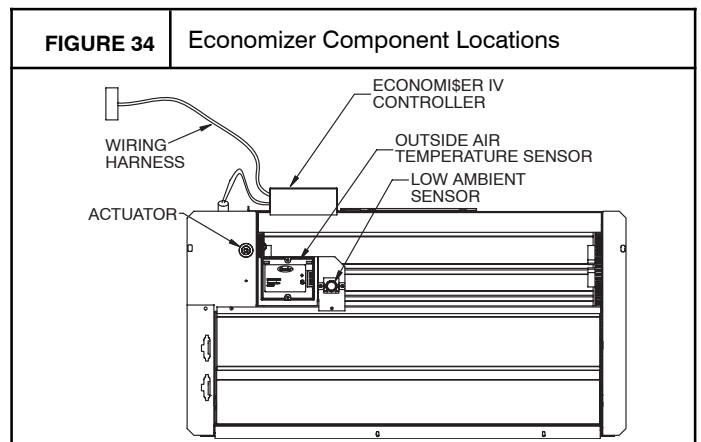
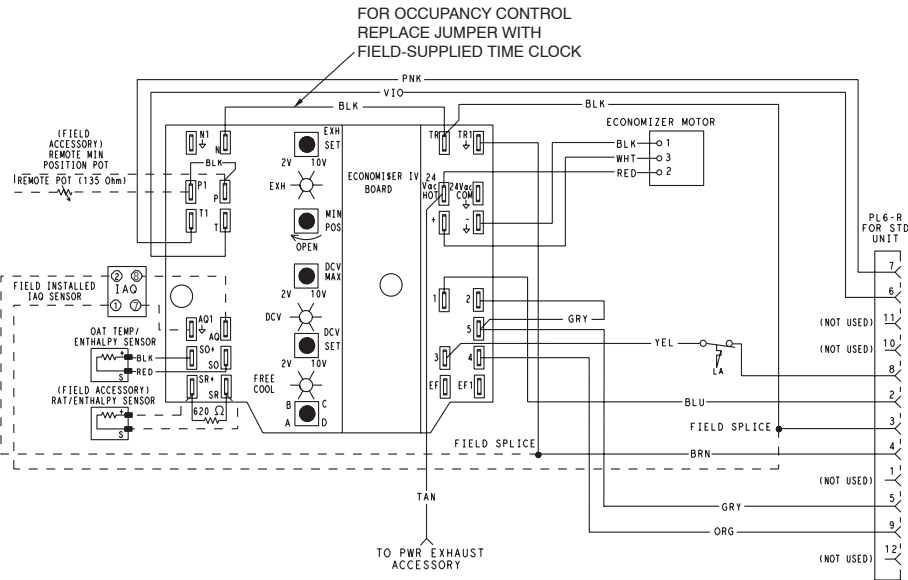

FIGURE 35

Economizer Wiring



LEGEND
DCV— Demand Controlled Ventilation
IAQ — Indoor Air Quality
LA — Low Ambient Lockout Device
OAT — Outdoor-Air Temperature
POT — Potentiometer
RAT — Return-Air Temperature

Potentiometer Defaults Settings:
 Power Exhaust Middle
 Minimum Pos. Fully Closed
 DCV Max. Middle
 DCV Set Middle
 Enthalpy C Setting

NOTES:
 1. 620 ohm, 1 watt 5% resistor should be removed only when using differential enthalpy or dry bulb.
 2. If a separate field-supplied 24 v transformer is used for the IAQ sensor power supply, it cannot have the secondary of the transformer grounded.
 3. For field-installed remote minimum position POT, remove black wire jumper between P and P1 and set control minimum position POT to the minimum position.

Table 15 – EconoMi\$er IV Input/Output Logic

Demand Control Ventilation (DCV)	INPUTS				OUTPUTS			
	Enthalpy*		Y1	Y2	Compressor		N Terminal†	
	Outdoor	Return			Stage 1	Stage 2	Occupied	Unoccupied
Below set (DCV LED Off)	High (Free Cooling LED Off)	Low	On	On	On	On	Minimum position	Closed
			On	Off	On	Off		
	Low (Free Cooling LED On)	High	On	On	On	Off	Modulating** (between min. position and full-open)	Modulating** (between closed and full-open)
			Off	Off	Off	Off		
Above set (DCV LED On)	High (Free Cooling LED Off)	Low	On	On	On	On	Modulating†† (between min. position and DCV maximum)	Modulating†† (between closed and DCV maximum)
			On	Off	On	Off		
	Low (Free Cooling LED On)	High	On	On	On	Off	Modulating***	Modulating†††
			On	Off	Off	Off		

* For single enthalpy control, the module compares outdoor enthalpy to the ABCD setpoint.
 † Power at N terminal determines Occupied/Unoccupied setting: 24 vac (Occupied), no power (Unoccupied).
 ** Modulation is based on the supply-air sensor signal.
 †† Modulation is based on the DCV signal.
 *** Modulation is based on the greater of DCV and supply-air sensor signals, between minimum position and either maximum position (DCV) or fully open (supply-air signal).
 ††† Modulation is based on the greater of DCV and supply-air sensor signals, between closed and either maximum position (DCV) or fully open (supply-air signal).

FIGURE 36

Economizer Functional View

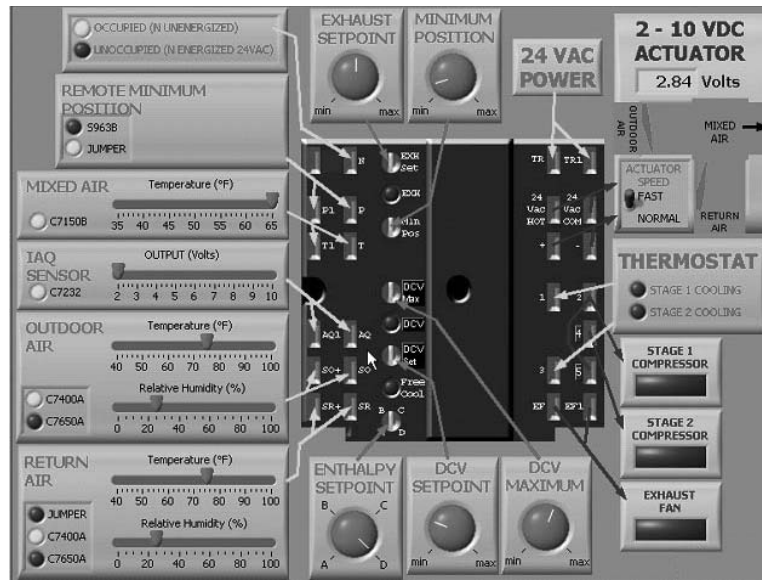

EconoMiSer IV

Table 15 provides a summary of EconoMiSer IV. Troubleshooting instructions are enclosed.

A functional view of the EconoMiSer is shown in Fig. 36. Typical settings, sensor ranges, and jumper positions are also shown. An EconoMiSer IV simulator program is available from Honeywell’s web site to help with EconoMiSer IV training and troubleshooting.

EconoMiSer IV Standard Sensors

Outdoor Air Temperature (OAT) Sensor

The outdoor air temperature sensor (HH57AC074) is a 10 to 20 mA device used to measure the outdoor-air temperature. The outdoor-air temperature is used to determine when the EconoMiSer IV can be used for free cooling. The sensor is factory-installed on the EconoMiSer IV in the outdoor airstream. (See Fig. 37.) The operating range of temperature measurement is 40° to 100°F (4° to 38°C).

Supply Air Temperature (SAT) Sensor

The supply air temperature sensor is a 3 K thermistor located at the inlet of the indoor fan. (See Fig. 37.) This sensor is factory installed. The operating range of temperature measurement is 0° to 158°F (-18° to 70°C). See Table 16 for sensor temperature/resistance values.

Table 16 – Thermistor Resistance vs Temperature Values for Space Temperature Sensor, Supply Air Temperature Sensor, and Outdoor Air Temperature Sensor

TEMP (C)	TEMP (F)	RESISTANCE (Ohms)
-40	-40	335,651
-35	-31	242,195
-30	-22	176,683
-25	-13	130,243
-20	-4	96,974
-15	5	72,895
-10	14	55,298
-5	23	42,315
0	32	32,651
5	41	25,395
10	50	19,903
15	59	15,714
20	68	12,494
25	77	10,000
30	86	8,056
35	95	6,530
40	104	5,325
45	113	4,367
50	122	3,601
55	131	2,985
60	140	2,487
65	149	2,082
70	158	1,752

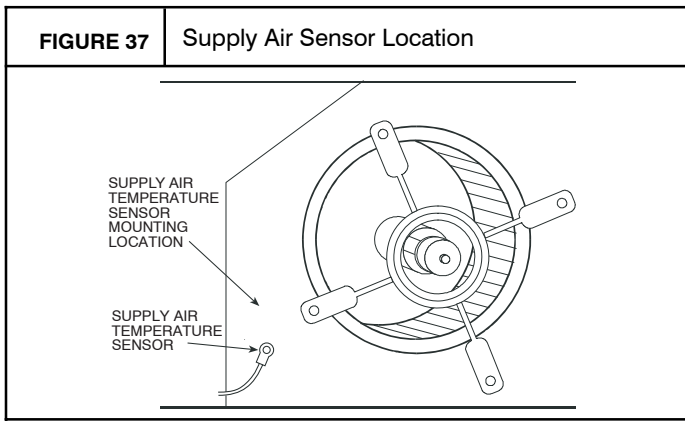

The temperature sensor looks like an eyelet terminal with wires running to it. The sensor is located in the “crimp end” and is sealed from moisture.

Outdoor Air Lockout Sensor

The EconoMi\$er IV is equipped with an ambient temperature lockout switch located in the outdoor airstream which is used to lock out the compressors below a 42°F (6°C) ambient temperature. (See Fig. 33.)

EconoMi\$er IV Control Modes

Determine the EconoMi\$er IV control mode before set up of the control. Some modes of operation may require different sensors. (See Table 17.) The EconoMi\$er IV is supplied from the factory with a supply-air temperature sensor and an outdoor-air temperature sensor. This allows for operation of the EconoMi\$er IV with outdoor air dry bulb changeover control. Additional accessories can be added to allow for different types of changeover control and operation of the EconoMi\$er IV and unit.

Outdoor Dry Bulb Changeover

The standard controller is shipped from the factory configured for outdoor dry bulb changeover control. The outdoor air and supply air temperature sensors are included as standard. For this control mode, the outdoor temperature is compared to an adjustable setpoint selected on the control. If the outdoor-air temperature is above the setpoint, the EconoMi\$er IV will adjust the outside air dampers to minimum position. If the outdoor-air temperature is below the setpoint, the position of the outside air dampers will be controlled to provided free cooling using outdoor air. When in this mode, the LED next to the free cooling setpoint potentiometer will be on. The changeover temperature setpoint is controlled by the free cooling setpoint potentiometer located on the control. (See Fig. 38.) The scale on the potentiometer is A, B, C, and D. See Fig. 39 for the corresponding temperature changeover values.

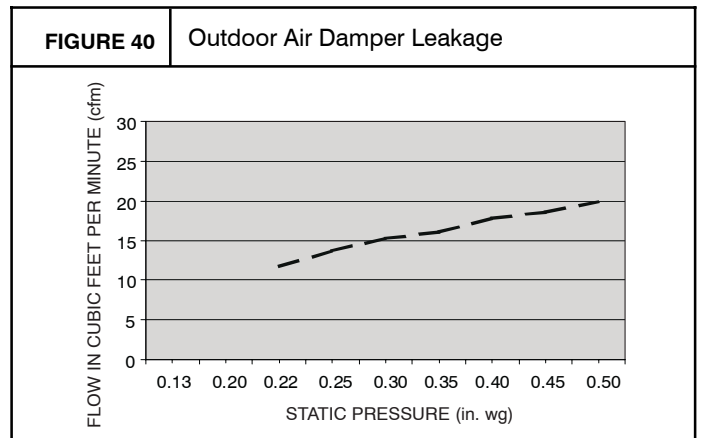
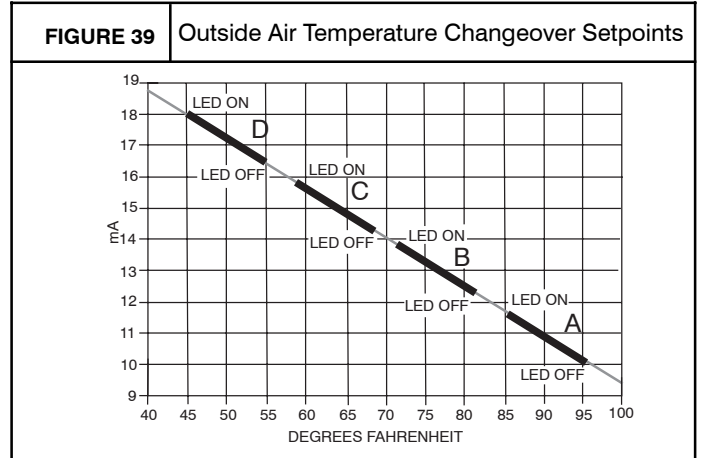
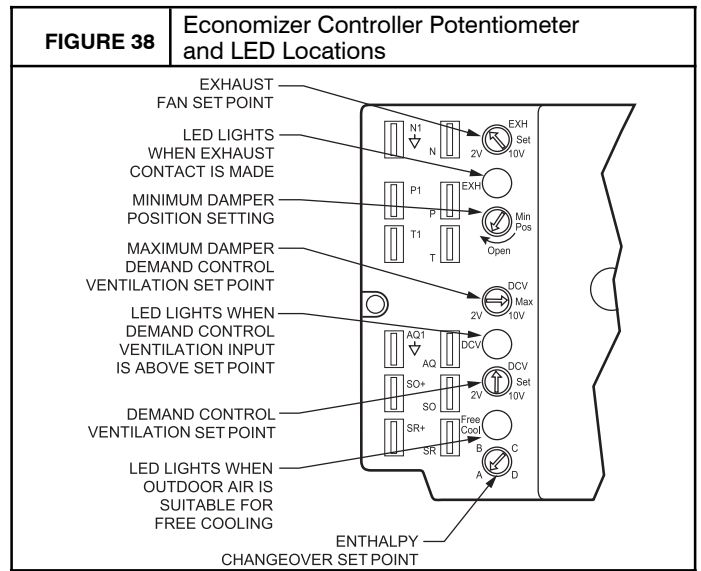

Differential Dry Bulb Control

For differential dry bulb control the standard outdoor dry bulb sensor is used in conjunction with an additional accessory dry bulb sensor (part number DNTEMPN002A00). The accessory sensor must be mounted in the return airstream. (See Fig. 41.) Wiring is provided in the EconoMi\$er IV wiring harness. (See Fig. 33.)

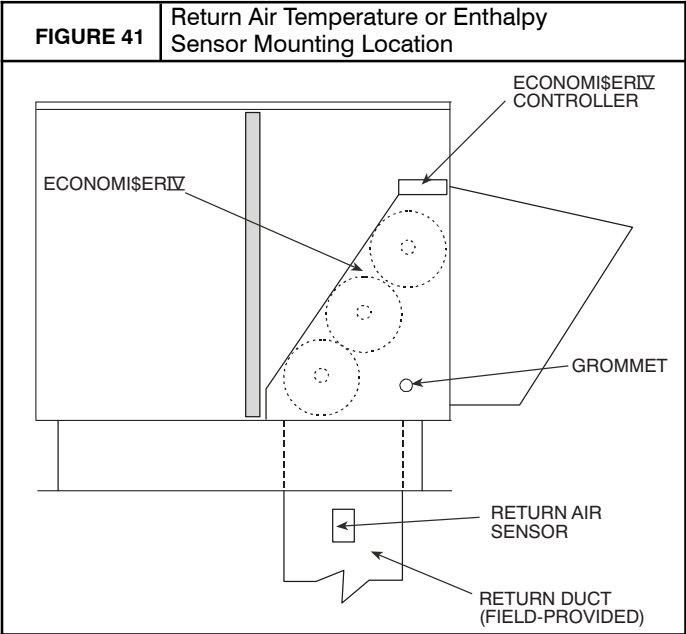

In this mode of operation, the outdoor-air temperature is compared to the return-air temperature and the lower temperature airstream is used for cooling. When using this mode of changeover control, turn the enthalpy setpoint potentiometer fully clockwise to the D setting. (See Fig. 38.)

Outdoor Enthalpy Changeover

For enthalpy control, accessory enthalpy sensor (part number AXB078ENT) is required. Replace the standard outdoor dry

bulb temperature sensor with the accessory enthalpy sensor in the same mounting location. (See Fig. 34.) When the outdoor air enthalpy rises above the outdoor enthalpy changeover setpoint, the outdoor-air damper moves to its minimum position. The outdoor enthalpy changeover setpoint is set with the outdoor enthalpy setpoint potentiometer on the EconoMi\$er IV controller. The setpoints are A, B, C, and D. (See Fig. 39.) The factory-installed 620-ohm jumper must be in place across terminals S_R and SR+ on the EconoMi\$er IV controller.

Differential Enthalpy Control

For differential enthalpy control, the EconoMi\$er IV controller uses two enthalpy sensors (AXB078ENT and DNENTDIF004A00), one in the outside air and one in the return air duct. The EconoMi\$er IV controller compares the outdoor air enthalpy to the return air enthalpy to determine EconoMi\$er IV use. The controller selects the lower enthalpy air (return or outdoor) for cooling. For example, when the outdoor air has a lower enthalpy than the return air, the EconoMi\$er IV opens to bring in outdoor air for free cooling.

Replace the standard outside air dry bulb temperature sensor with the accessory enthalpy sensor in the same mounting location. (See Fig. 32.) Mount the return air enthalpy sensor in the return air duct. (See Fig. 41.) Wiring is provided in the EconoMi\$er IV wiring harness. (See Fig. 35.) The outdoor enthalpy changeover setpoint is set with the outdoor enthalpy setpoint potentiometer on the EconoMi\$er IV controller. When using this mode of changeover control, turn the enthalpy setpoint potentiometer fully clockwise to the D setting.

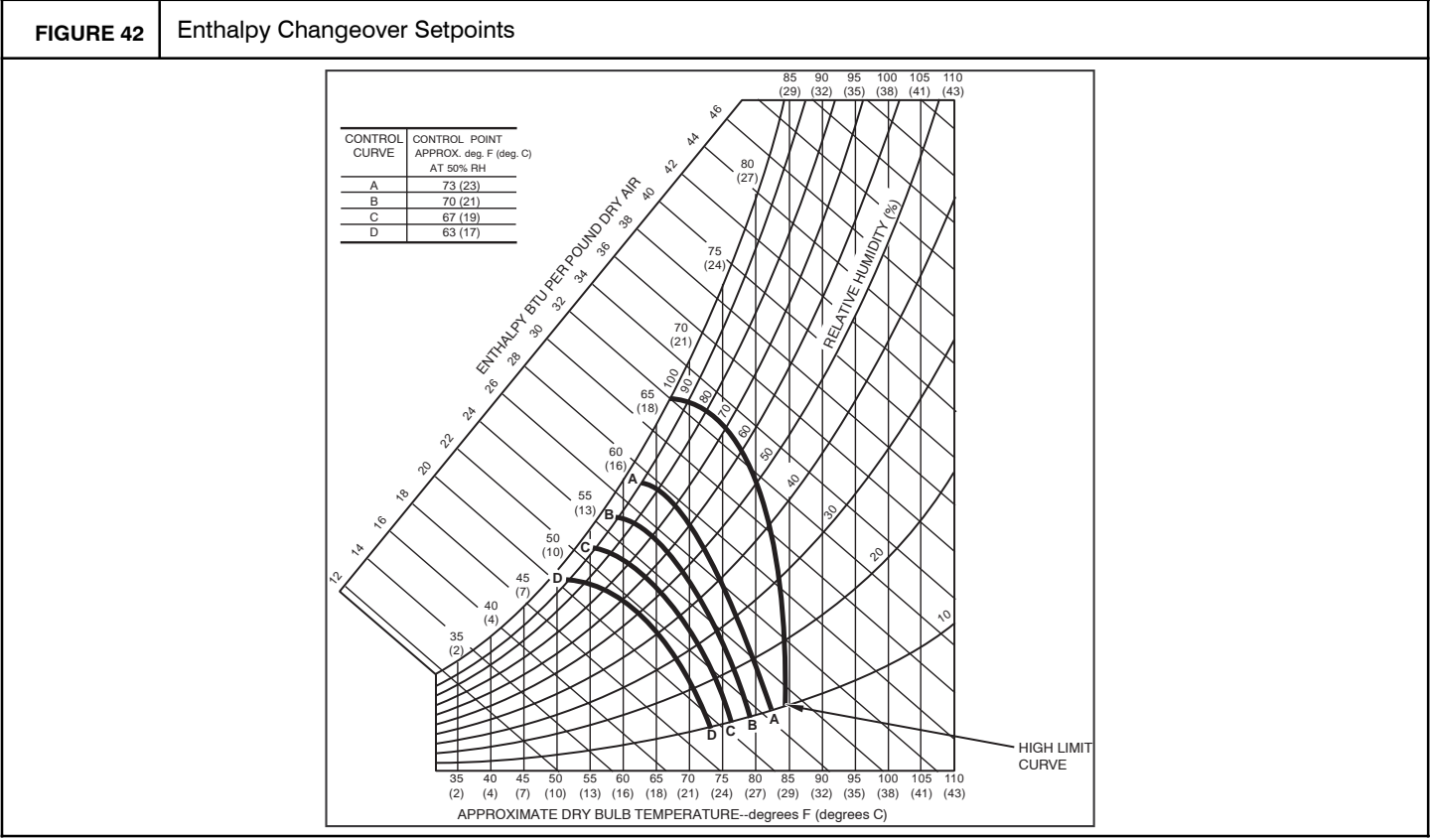

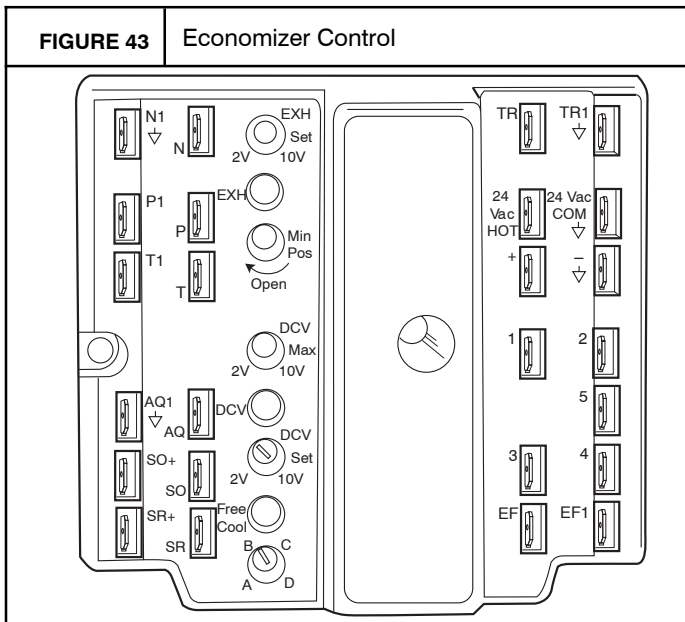

Indoor Air Quality (IAQ) Sensor Input

The IAQ input can be used for demand control ventilation control based on the level of CO₂ measured in the space or return air duct.

Mount the accessory IAQ sensor according to manufacturer specifications. The IAQ sensor should be wired to the AQ and AQ1 terminals of the controller. Adjust the DCV potentiometers to correspond to the DCV voltage output of the indoor air quality sensor at the user-determined setpoint. (See Fig. 44.)

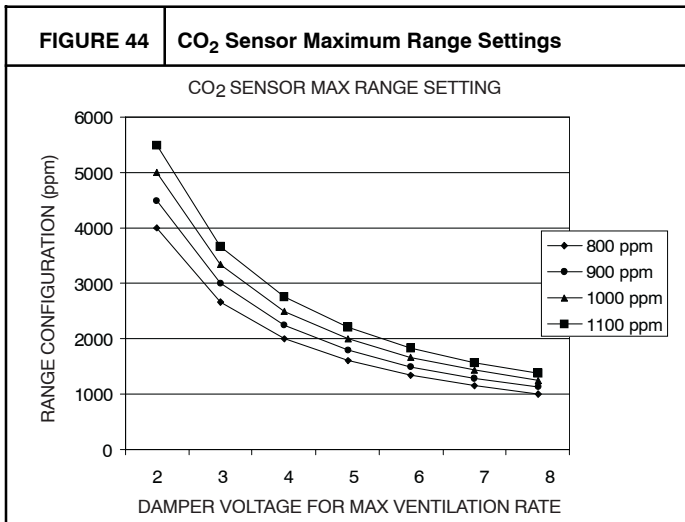

If a separate field-supplied transformer is used to power the IAQ sensor, the sensor must not be grounded or the EconoMi\$er IV control board will be damaged.

When using demand ventilation, the minimum damper position represents the minimum ventilation position for VOC (volatile organic compounds) ventilation requirements. The maximum demand ventilation position is used for fully occupied ventilation.

When demand ventilation control is not being used, the minimum position potentiometer should be used to set the occupied ventilation position. The maximum demand ventilation position should be turned fully clockwise.

Exhaust Setpoint Adjustment

The exhaust setpoint will determine when the exhaust fan runs based on damper position (if accessory power exhaust is

installed). The setpoint is modified with the Exhaust Fan Setpoint (EXH SET) potentiometer. (See Fig. 38.) The setpoint represents the damper position above which the exhaust fans will be turned on. When there is a call for exhaust, the EconoMi\$er IV controller provides a 45 ± 15 second delay before exhaust fan activation to allow the dampers to open. This delay allows the damper to reach the appropriate position to avoid unnecessary fan overload.

Minimum Position Control

There is a minimum damper position potentiometer on the EconoMi\$er IV controller. (See Fig. 38.) The minimum damper position maintains the minimum airflow into the building during the occupied period.

When using demand ventilation, the minimum damper position represents the minimum ventilation position for VOC (volatile organic compound) ventilation requirements. The maximum demand ventilation position is used for fully occupied ventilation.

When demand ventilation control is not being used, the minimum position potentiometer should be used to set the occupied ventilation position. The maximum demand ventilation position should be turned fully clockwise.

Adjust the minimum position potentiometer to allow the minimum amount of outdoor air, as required by local codes, to enter the building. Make minimum position adjustments with at least 10°F temperature difference between the outdoor and return-air temperatures.

To determine the minimum position setting, perform the following procedure:

1. Calculate the appropriate mixed air temperature using the following formula:

$$(T_O \times \frac{OA}{100}) + (T_R \times \frac{RA}{100}) = T_M$$

T_O = Outdoor-Air Temperature

OA = Percent of Outdoor Air

T_R = Return-Air Temperature

RA = Percent of Return Air

T_M = Mixed-Air Temperature

As an example, if local codes require 10% outdoor air during occupied conditions, outdoor-air temperature is 60°F, and return-air temperature is 75°F.

$$(60 \times .10) + (75 \times .90) = 73.5^\circ\text{F}$$

2. Disconnect the supply air sensor from terminals T and T1.
3. Ensure that the factory-installed jumper is in place across terminals P and P1. If remote damper positioning is being used, make sure that the terminals are wired according to Fig. 41 and that the minimum position potentiometer is turned fully clockwise.
4. Connect 24 vac across terminals TR and TR1.
5. Carefully adjust the minimum position potentiometer until the measured mixed air temperature matches the calculated value.
6. Reconnect the supply air sensor to terminals T and T1.

Remote control of the EconoMi\$er IV damper is desirable when requiring additional temporary ventilation. If a field-supplied remote potentiometer (Honeywell part number S963B1128) is

wired to the EconoMi\$er IV controller, the minimum position of the damper can be controlled from a remote location.

To control the minimum damper position remotely, remove the factory-installed jumper on the P and P1 terminals on the EconoMi\$er IV controller. Wire the field-supplied potentiometer to the P and P1 terminals on the EconoMi\$er IV controller. (See Fig. 35).

Damper Movement

Damper movement from full open to full closed (or vice versa) takes 2-1/2 minutes.

Thermostats

The EconoMi\$er IV control works with conventional commercial thermostats that have a Y1 (cool stage 1), Y2 (cool stage 2), W1 (heat stage 1), W2 (heat stage 2), and G (fan). The EconoMi\$er IV control does not support space temperature sensors. Connections are made at the thermostat terminal connection board located in the main control box.

Occupancy Control

The factory default configuration for the EconoMi\$er IV control is occupied mode. Occupied status is provided by the black jumper from terminal TR to terminal N. When unoccupied mode is desired, install a field-supplied timeclock function in place of the jumper between TR and N. (See Fig. 34.) When the timeclock contacts are closed, the EconoMi\$er IV control will be in occupied mode. When the timeclock contacts are open (removing the 24-v signal from terminal N), the EconoMi\$er IV will be in unoccupied mode.

Demand Control Ventilation (DCV)

When using the EconoMi\$er IV for demand controlled ventilation, there are some equipment selection criteria which should be considered. When selecting the heat capacity and cool capacity of the equipment, the maximum ventilation rate must be evaluated for design conditions. The maximum damper position must be calculated to provide the desired fresh air.

Typically the maximum ventilation rate will be about 5 to 10% more than the typical cfm required per person, using normal outside air design criteria.

A proportional anticipatory strategy should be taken with the following conditions: a zone with a large area, varied occupancy, and equipment that cannot exceed the required ventilation rate at design conditions. Exceeding the required ventilation rate means the equipment can condition air at a maximum ventilation rate that is greater than the required ventilation rate for maximum occupancy. A proportional-anticipatory strategy will cause the fresh air supplied to increase as the room CO₂ level increases even though the CO₂ setpoint has not been reached. By the time the CO₂ level reaches the setpoint, the damper will be at maximum ventilation and should maintain the setpoint.

In order to have the CO₂ sensor control the economizer damper in this manner, first determine the damper voltage output for

minimum or base ventilation. Base ventilation is the ventilation required to remove contaminants during unoccupied periods. The following equation may be used to determine the percent of outside air entering the building for a given damper position. For best results there should be at least a 10 degree difference in outside and return-air temperatures.

$$(T_O \times \frac{OA}{100}) + (T_R \times \frac{RA}{100}) = T_M$$

T_O = Outdoor-Air Temperature

OA = Percent of Outdoor Air

T_R = Return-Air Temperature

RA = Percent of Return Air

T_M = Mixed-Air Temperature

Once base ventilation has been determined, set the minimum damper position potentiometer to the correct position.

The same equation can be used to determine the occupied or maximum ventilation rate to the building. For example, an output of 3.6 volts to the actuator provides a base ventilation rate of 5% and an output of 6.7 volts provides the maximum ventilation rate of 20% (or base plus 15 cfm per person). Use Fig. 51 to determine the maximum setting of the CO₂ sensor. For example, an 1100 ppm setpoint relates to a 15 cfm per person design. Use the 1100 ppm curve on Fig. 51 to find the point when the CO₂ sensor output will be 6.7 volts. Line up the point on the graph with the left side of the chart to determine that the range configuration for the CO₂ sensor should be 1800 ppm. The EconoMi\$er IV controller will output the 6.7 volts from the CO₂ sensor to the actuator when the CO₂ concentration in the space is at 1100 ppm. The DCV setpoint may be left at 2 volts since the CO₂ sensor voltage will be ignored by the EconoMi\$er IV controller until it rises above the 3.6 volt setting of the minimum position potentiometer.

Once the fully occupied damper position has been determined, set the maximum damper demand control ventilation potentiometer to this position. Do not set to the maximum position as this can result in over-ventilation to the space and potential high humidity levels.

CO₂ Sensor Configuration

The CO₂ sensor has preset standard voltage settings that can be selected anytime after the sensor is powered up. (See Table 17.) Use setting 1 or 2 for RGS equipment. (See Table 17.)

1. Press Clear and Mode buttons. Hold at least 5 seconds until the sensor enters the Edit mode.
2. Press Mode twice. The STDSET Menu will appear.
3. Use the Up/Down button to select the preset number. (See Table 17.)
4. Press Enter to lock in the selection.
5. Press Mode to exit and resume normal operation.

Table 17 – EconoMi\$er IV Sensor Usage

APPLICATION	ECONOMISER IV WITH OUTDOOR AIR DRY BULB SENSOR		
	Accessories Required		
Outdoor Air Dry Bulb	None. The outdoor air dry bulb sensor is factory installed.		
Differential Dry Bulb	DNTEMPSN002A00*		
Single Enthalpy	AXB078ENT		
Differential Enthalpy	AXB078ENT and DNENTDIF004A00*		
CO ₂ for DCV Control using a Wall-Mounted CO ₂ Sensor	33ZCSENCO2		
CO ₂ for DCV Control using a Duct-Mounted CO ₂ Sensor	33ZCSENCO2† and 33ZCASPCO2**	O R	DNCBDIOX005A00††

* DNENTDIF004A00 and DNTEMPSN002A00 accessories are used on many different base units. As such, these kits may contain parts that will not be needed for installation.

† 33ZCSENCO2 is an accessory CO₂ sensor.

** 33ZCASPCO2 is an accessory aspirator box required for duct-mounted applications.

†† DNCBDIOX005A00 is an accessory that contains both 33ZCSENCO2 and 33ZCASPCO2 accessories.

The custom settings of the CO₂ sensor can be changed anytime after the sensor is energized. Follow the steps below to change the non-standard settings:

1. Press Clear and Mode buttons. Hold at least 5 seconds until the sensor enters the Edit mode.
2. Press Mode twice. The STDSET Menu will appear.
3. Use the Up/Down button to toggle to the NONSTD menu and press Enter.
4. Use the Up/Down button to toggle through each of the nine variables, starting with Altitude, until the desired setting is reached.
5. Press Mode to move through the variables.
6. Press Enter to lock in the selection, then press Mode to continue to the next variable.

Dehumidification of Fresh Air with DCV (Demand Controlled Ventilation) Control

If normal rooftop heating and cooling operation is not adequate for the outdoor humidity level, an energy recovery unit and/or a dehumidification option should be considered.

EconoMi\$er IV Preparation

This procedure is used to prepare the EconoMi\$er IV for troubleshooting. No troubleshooting or testing is done by performing the following procedure.

NOTE: This procedure requires a 9-v battery, 1.2 kilo-ohm resistor, and a 5.6 kilo-ohm resistor which are not supplied with the EconoMi\$er IV.

IMPORTANT: Be sure to record the positions of all potentiometers before starting troubleshooting.

1. Disconnect power at TR and TR1. All LEDs should be off. Exhaust fan contacts should be open.
2. Disconnect device at P and P1.
3. Jumper P to P1.
4. Disconnect wires at T and T1. Place 5.6 kilo-ohm resistor across T and T1.
5. Jumper TR to 1.

6. Jumper TR to N.
7. If connected, remove sensor from terminals SO and +. Connect 1.2 kilo-ohm 4074EJM checkout resistor across terminals SO and +.
8. Put 620-ohm resistor across terminals SR and +.
9. Set minimum position, DCV setpoint, and exhaust potentiometers fully CCW (counterclockwise).
10. Set DCV maximum position potentiometer fully CW (clockwise).
11. Set enthalpy potentiometer to D.
12. Apply power (24 vac) to terminals TR and TR1.

Differential Enthalpy

To check differential enthalpy:

1. Make sure EconoMi\$er IV preparation procedure has been performed.
2. Place 620-ohm resistor across SO and +.
3. Place 1.2 kilo-ohm resistor across SR and +. The Free Cool LED should be lit.
4. Remove 620-ohm resistor across SO and +. The Free Cool LED should turn off.
5. Return EconoMi\$er IV settings and wiring to normal after completing troubleshooting.

Single Enthalpy

To check single enthalpy:

1. Make sure EconoMi\$er IV preparation procedure has been performed.
2. Set the enthalpy potentiometer to A (fully CCW). The Free Cool LED should be lit.
3. Set the enthalpy potentiometer to D (fully CW). The Free Cool LED should turn off.
4. Return EconoMi\$er IV settings and wiring to normal after completing troubleshooting.

DCV (Demand Controlled Ventilation) and Power Exhaust

To check DCV and Power Exhaust:

1. Make sure EconoMi\$er IV preparation procedure has been performed.
2. Ensure terminals AQ and AQ1 are open. The LED for both DCV and Exhaust should be off. The actuator should be fully closed.
3. Connect a 9-v battery to AQ (positive node) and AQ1 (negative node). The LED for both DCV and Exhaust should turn on. The actuator should drive to between 90 and 95% open.
4. Turn the Exhaust potentiometer CW until the Exhaust LED turns off. The LED should turn off when the potentiometer is approximately 90%. The actuator should remain in position.
5. Turn the DCV setpoint potentiometer CW until the DCV LED turns off. The DCV LED should turn off when the potentiometer is approximately 9-v. The actuator should drive fully closed.
6. Turn the DCV and Exhaust potentiometers CCW until the Exhaust LED turns on. The exhaust contacts will close 30 to 120 seconds after the Exhaust LED turns on.

7. Return EconoMi\$er IV settings and wiring to normal after completing troubleshooting.

DCV Minimum and Maximum Position

To check the DCV minimum and maximum position:

1. Make sure EconoMi\$er IV preparation procedure has been performed.
2. Connect a 9-v battery to AQ (positive node) and AQ1 (negative node). The DCV LED should turn on. The actuator should drive to between 90 and 95% open.
3. Turn the DCV Maximum Position potentiometer to midpoint. The actuator should drive to between 20 and 80% open.
4. Turn the DCV Maximum Position potentiometer to fully CCW. The actuator should drive fully closed.
5. Turn the Minimum Position potentiometer to midpoint. The actuator should drive to between 20 and 80% open.
6. Turn the Minimum Position Potentiometer fully CW. The actuator should drive fully open.
7. Remove the jumper from TR and N. The actuator should drive fully closed.
8. Return EconoMi\$er IV settings and wiring to normal after completing troubleshooting.

Supply-Air Sensor Input

To check supply-air sensor input:

1. Make sure EconoMi\$er IV preparation procedure has been performed.
2. Set the Enthalpy potentiometer to A. The Free Cool LED turns on. The actuator should drive to between 20 and 80% open.
3. Remove the 5.6 kilo-ohm resistor and jumper T to T1. The actuator should drive fully open.
4. Remove the jumper across T and T1. The actuator should drive fully closed.
5. Return EconoMi\$er IV settings and wiring to normal after completing troubleshooting.

EconoMi\$er IV Troubleshooting Completion

This procedure is used to return the EconoMi\$er IV to operation. No troubleshooting or testing is done by performing the following procedure.

1. Disconnect power at TR and TR1.
2. Set enthalpy potentiometer to previous setting.
3. Set DCV maximum position potentiometer to previous setting.
4. Set minimum position, DCV setpoint, and exhaust potentiometers to previous settings.
5. Remove 620-ohm resistor from terminals SR and +.
6. Remove 1.2 kilo-ohm checkout resistor from terminals SO and +. If used, reconnect sensor from terminals SO and +.
7. Remove jumper from TR to N.
8. Remove jumper from TR to 1.
9. Remove 5.6 kilo-ohm resistor from T and T1. Reconnect wires at T and T1.
10. Remove jumper from P to P1. Reconnect device at P and P1.
11. Apply power (24 vac) to terminals TR and TR1.

WIRING DIAGRAMS

See Fig. 45 and Fig. 46 for typical wiring diagrams.

PRE-START-UP

⚠ WARNING

PERSONAL INJURY HAZARD

Failure to follow this warning could result in personal injury or death.

1. Follow recognized safety practices and wear protective goggles when checking or servicing refrigerant system.
2. Do not operate compressor or provide any electric power to unit unless compressor terminal cover is in place and secured.
3. Do not remove compressor terminal cover until all electrical sources are disconnected.
4. Relieve all pressure from system before touching or disturbing anything inside terminal box if refrigerant leak is suspected around compressor terminals.
5. Never attempt to repair soldered connection while refrigerant system is under pressure.
6. Do not use torch to remove any component. System contains oil and refrigerant under pressure. To remove a component, wear protective goggles and proceed as follows:
 - a. Shut off electrical power and then gas to unit.
 - b. Recover refrigerant to relieve all pressure from system using both high-pressure and low pressure ports.
 - c. Cut component connection tubing with tubing cutter and remove component from unit.
 - d. Carefully unsweat remaining tubing stubs when necessary. Oil can ignite when exposed to torch flame.

Proceed as follows to inspect and prepare the unit for initial start-up:

1. Remove all access panels.
2. Read and follow instructions on all WARNING, CAUTION, and INFORMATION labels attached to, or shipped with, unit.
3. Make the following inspections:
 - a. Inspect for shipping and handling damages such as broken lines, loose parts, or disconnected wires, etc.
 - b. Inspect for oil at all refrigerant tubing connections and on unit base. Detecting oil generally indicates a refrigerant leak. Leak-test all refrigerant tubing connections using electronic leak detector, halide torch, or liquid-soap solution.
 - c. Inspect all field-wiring and factory-wiring connections. Be sure that connections are completed and tight. Be sure that wires are not in contact with refrigerant tubing or sharp edges.

- d. Inspect coil fins. If damaged during shipping and handling, carefully straighten fins with a fin comb.
4. Verify the following conditions:
- a. Make sure that condenser-fan blade are correctly positioned in fan orifice. See Condenser-Fan Adjustment section for more details.
 - b. Make sure that air filter(s) is in place.
 - c. Make sure that condensate drain trap is filled with water to ensure proper drainage.
 - d. Make sure that all tools and miscellaneous loose parts have been removed.

START-UP, GENERAL

Unit Preparation

Make sure that unit has been installed in accordance with installation instructions and applicable codes.

Gas Piping

Check gas piping for leaks.



WARNING

UNIT OPERATION AND SAFETY HAZARD

Failure to follow this warning could result in personal injury or death.

Disconnect gas piping from unit when leak testing at pressure greater than 1/2 psig. Pressures greater than 1/2 psig will cause gas valve damage resulting in hazardous condition. If gas valve is subjected to pressure greater than 1/2 psig, it must be replaced before use. When pressure testing field-supplied gas piping at pressures of 1/2 psig or less, a unit connected to such piping must be isolated by manually closing the gas valve.

Return-Air Filters

Make sure correct filters are installed in unit (see Appendix II - Physical Data). Do not operate unit without return-air filters.

Outdoor-Air Inlet Screens

Outdoor-air inlet screen must be in place before operating unit.

Compressor Mounting

Compressors are internally spring mounted. Do not loosen or remove compressor hold down bolts.

Internal Wiring

Check all electrical connections in unit control boxes. Tighten as required.

Refrigerant Service Ports

Each unit system has two 1/4" SAE flare (with check valves) service ports: one on the suction line, and one on the compressor discharge line. Be sure that caps on the ports are tight.

Compressor Rotation

On 3-phase units with scroll compressors, it is important to be certain compressor is rotating in the proper direction. To determine whether or not compressor is rotating in the proper direction:

1. Connect service gauges to suction and discharge pressure fittings.
2. Energize the compressor.
3. The suction pressure should drop and the discharge pressure should rise, as is normal on any start-up.

If the suction pressure does not drop and the discharge pressure does not rise to normal levels:

1. Note that the evaporator fan is probably also rotating in the wrong direction.
2. Turn off power to the unit and install lockout tag.
3. Reverse any two of the unit power leads.
4. Re-energize to the compressor. Check pressures.

The suction and discharge pressure levels should now move to their normal start-up levels.

NOTE: When the compressor is rotating in the wrong direction, the unit will make an elevated level of noise and will not provide cooling.

Cooling

Set space thermostat to OFF position. To start unit, turn on main power supply. Set system selector switch at COOL position and fan switch at AUTO. position. Adjust thermostat to a setting below room temperature. Compressor starts on closure of contactor.

Check unit charge. Refer to Refrigerant Charge section.

Reset thermostat at a position above room temperature. Compressor will shut off. Evaporator fan will shut off after a 30-second delay.

To shut off unit, set system selector switch at OFF position. Resetting thermostat at a position above room temperature shuts unit off temporarily until space temperature exceeds thermostat setting.

Main Burners

Main burners are factory set and should require no adjustment.

To check ignition of main burners and heating controls, move thermostat setpoint above room temperature and verify that the burners light and evaporator fan is energized. Check heating effect, then lower the thermostat setting below the room temperature and verify that the burners and evaporator fan turn off.

Refer to Table 11 and Table 12 for the correct orifice to use at high altitudes.

Heating

1. Purge gas supply line of air by opening union ahead of the gas valve. If gas odor is detected, tighten union and wait 5 minutes before proceeding.
2. Turn on electrical supply and manual gas valve.

3. Set system switch selector at HEAT position and fan switch at AUTO. or ON position. Set heating temperature lever above room temperature.
4. The induced-draft motor will start.
5. After a call for heating, the main burners should light within 5 seconds. If the burner does not light, then there is a 22-second delay before another 5-second try. If the burner still does not light, the time delay is repeated. If the burner does not light within 15 minutes, there is a lockout. To reset the control, break the 24 v power to W1.
6. The evaporator-fan motor will turn on 45 seconds after burner ignition.
7. The evaporator-fan motor will turn off in 45 seconds after the thermostat temperature is satisfied.
8. Adjust airflow to obtain a temperature rise within the range specified on the unit nameplate.

NOTE: The default value for the evaporator-fan motor on/off delay is 45 seconds. The Integrated Gas Unit Controller (IGC) modifies this value when abnormal limit switch cycles occur. Based upon unit operating conditions, the on delay can be reduced to 0 seconds and the off delay can be extended to 180 seconds. When one flash of the LED is observed, the evaporator-fan on/off delay has been modified.

If the limit switch trips at the start of the heating cycle during the evaporator on delay, the time period of the on delay for the next cycle will be 5 seconds less than the time at which the switch tripped. (Example: If the limit switch trips at 30 seconds, the evaporator-fan on delay for the next cycle will occur at 25 seconds.) To prevent short-cycling, a 5-second reduction will only occur if a minimum of 10 minutes has elapsed since the last call for heating.

The evaporator-fan off delay can also be modified. Once the call for heating has ended, there is a 10-minute period during which the modification can occur. If the limit switch trips during this period, the evaporator-fan off delay will increase by 15 seconds. A maximum of 9 trips can occur, extending the evaporator-fan off delay to 180 seconds.

To restore the original default value, reset the power to the unit.

To shut off unit, set system selector switch at OFF position. Resetting heating selector lever below room temperature will temporarily shut unit off until space temperature falls below thermostat setting.

Ventilation (Continuous Fan)

Set fan and system selector switches at ON and OFF positions, respectively. Evaporator fan operates continuously to provide constant air circulation. When the evaporator-fan selector switch is turned to the OFF position, there is a 30-second delay before the fan turns off.

OPERATING SEQUENCES

Cooling, Unit Without Economizer

When thermostat calls for cooling, terminals G and Y1 are energized. The indoor-fan contactor (IFC) and compressor contactor are energized and indoor-fan motor, compressor, and outdoor fan start. The outdoor fanmotor runs continuously while unit is cooling.

Heating, Unit Without Economizer

When the thermostat calls for heating, terminal W1 is energized. To prevent thermostat short-cycling, the unit is locked into the Heating mode for at least 1 minute when W1 is energized. The induced-draft motor is energized and the burner ignition sequence begins. The indoor (evaporator) fan motor (IFM) is energized 45 seconds after a flame is ignited. On units equipped for two stages of heat, when additional heat is needed, W2 is energized and the high-fire solenoid on the main gas valve (MGV) is energized. When the thermostat is satisfied and W1 is deenergized, the IFM stops after a 45-second time-off delay.

Cooling, Unit With EconoMiSer IV

For Occupied mode operation of EconoMiSer IV, there must be a 24-v signal at terminals TR and N (provided through PL6-3 from the unit's IFC coil). Removing the signal at N places the EconoMiSer IV control in Unoccupied mode.

During Occupied mode operation, indoor fan operation will be accompanied by economizer dampers moving to Minimum Position setpoint for ventilation. If indoor fan is off, dampers will close. During Unoccupied mode operation, dampers will remain closed unless a Cooling (by free cooling) or DCV demand is received.

Integrated EconoMiSer IV operation on RGS single compressor model requires a 2-stage thermostat (Y1 and Y2 switches).

When free cooling using outside air is not available, the unit cooling sequence will be controlled directly by the space thermostat as described above as Cooling, Without Economizer. Outside air damper position will be closed or Minimum Position as determined by occupancy mode and fan signal.

When free cooling is available as determined by the appropriate changeover command (dry bulb, outdoor enthalpy, differential dry bulb or differential enthalpy), a call for cooling (Y1 closes at the thermostat) will cause the economizer control to modulate the dampers open and closed to maintain the unit supply air temperature at 50 to 55°F. Compressor will not run.

During free cooling operation, a supply air temperature (SAT) above 50°F will cause the dampers to modulate between Minimum Position setpoint and 100% open. With SAT from 50°F to 45°F, the dampers will maintain at the Minimum Position setting. With SAT below 45°F, the outside air dampers will be closed. When SAT rises to 48°F, the dampers will re-open to Minimum Position setting.

Should 100% outside air not be capable of satisfying the space temperature, space temperature will rise until Y2 is closed. The economizer control will call for compressor operation. Dampers will modulate to maintain SAT at 50 to 55°F concurrent with compressor operation. The Low Ambient Lockout Thermostat will block compressor operation with economizer operation below 42°F outside air temperature.

When space temperature demand is satisfied (thermostat Y1 opens), the dampers will return to Minimum Damper position if indoor fan is running or fully closed if fan is off.

If accessory power exhaust is installed, the power exhaust fan motors will be energized by the economizer control as the

dampers open above the PE-On setpoint and will be de-energized as the dampers close below the PE-On setpoint.

Damper movement from full closed to full open (or vice versa) will take between 1-1/2 and 2-1/2 minutes.

Heating With EconoMi\$er IV

During Occupied mode operation, indoor fan operation will be accompanied by economizer dampers moving to Minimum Position setpoint for ventilation. If indoor fan is off, dampers will close. During Unoccupied mode operation, dampers will remain closed unless a DCV demand is received.

When the room temperature calls for heat (W1 closes), the heating controls are energized as described in Heating, Unit Without Economizer above.

Demand Controlled Ventilation

If a field-installed CO₂ sensor is connected to the EconoMi\$er IV control, a Demand Controlled Ventilation strategy will

operate automatically. As the CO₂ level in the space increases above the CO₂ setpoint (on the EconoMi\$er IV controller), the minimum position of the dampers will be increased proportionally, until the Maximum Ventilation setting is reached. As the space CO₂ level decreases because of the increase in fresh air, the outdoor-damper will follow the higher demand condition from the DCV mode or from the free-cooling mode.

DCV operation is available in Occupied and Unoccupied periods with EconoMi\$er IV. However, a control modification will be required on the RGS unit to implement the Unoccupied period function.

FASTENER TORQUE VALUES

See Table 18 for torque values.

Table 18 – Torque Values

Supply fan motor mounting	120 +/- 12 in-lbs
Supply fan motor adjustment plate	120 +/- 12 in-lbs
Motor pulley setscrew	72 +/- 5 in-lbs
Fan pulley setscrew	72 +/- 5 in-lbs
Blower wheel hub setscrew	72 +/- 5 in-lbs
Bearing locking collar setscrew	65–70 in-lbs
Compressor mounting bolts	65–75 in-lbs
Condenser fan motor mounting bolts	20 +/- 2 in-lbs
Condenser fan hub setscrew	84 +/- 12 in-lbs

FIGURE 45 RGS Typical Unit Wiring Diagram - Power (060, 208/230-3-60)

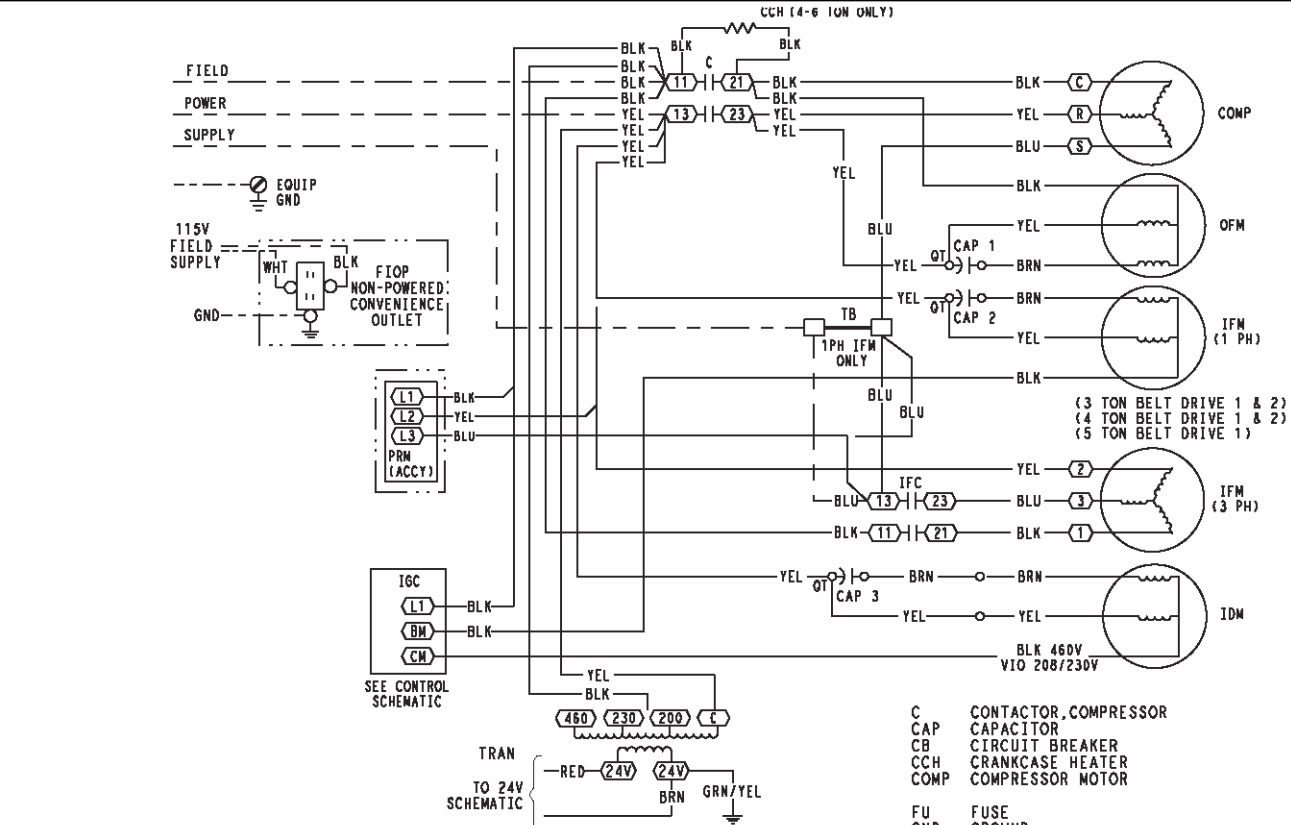

- LEGEND**
- MARKED WIRE
 - TERMINAL (MARKED)
 - TERMINAL (UNMARKED)
 - TERMINAL BLOCK
 - SPLICE
 - SPLICE (MARKED)
 - FACTORY WIRING
 - FIELD CONTROL WIRING
 - FIELD POWER WIRING
 - CIRCUIT BOARD TRACE
 - ACCESSORY OR OPTIONAL WIRING
 - TO INDICATE COMMON POTENTIAL ONLY: NOT TO REPRESENT WIRING

- NOTES**
1. IF ANY OF THE ORIGINAL WIRE FURNISHED MUST BE REPLACED. IT MUST BE REPLACED WITH TYPE 90 C WIRE OR ITS EQUIVALENT.
 2. COMPRESSOR AND FAN MOTORS ARE THERMALLY PROTECTED. THREE PHASE MOTORS ARE PROTECTED AGAINST PRIMARY SINGLE PHASING CONDITIONS.
 3. 208/230V UNIT TRAN IS WIRED FOR 230V UNIT. IF UNIT IS TO BE RUN WITH 208V POWER SUPPLY DISCONNECT BLK WIRE FROM 230V TAP AND CONNECT TO 200V TAP.
 4. USE COPPER, COPPER CLAD, ALUMINUM OR ALUMINUM CONNECTORS.
 5. USE COPPER CONDUCTOR ONLY.

- COMPONENTS**
- C CONTACTOR, COMPRESSOR
 - CAP CAPACITOR
 - CB CIRCUIT BREAKER
 - CCH CRANKCASE HEATER
 - COMP COMPRESSOR MOTOR
 - FU FUSE
 - GND GROUND
 - GVR GAS VALVE RELAY
 - HPS HIGH PRESSURE SWITCH
 - HS HALL EFFECT SENSOR
 - I IGNITOR
 - IAQ INDOOR AIR QUALITY SENSORS
 - IFC INDOOR FAN CONTACTOR
 - IFM INDOOR FAN MOTOR
 - IGC INTEGRATED GAS CONTROL
 - LA LOW AMBIENT LOCKOUT
 - LPS LOW PRESSURE SWITCH
 - LS LIMIT SWITCH
 - MGV MAIN GAS VALVE
 - OAT OUTDOOR AIR TEMP. SEN
 - OFM OUTDOOR FAN MOTOR
 - OLR OVERLOAD RELAY
 - PL PLUG ASSEMBLY
 - POT POTENTIOMETER
 - PRM PHASE MONITOR RELAY
 - QT QUADRUPLE TERMINAL
 - R RELAY
 - RAT RETURN AIR TEMP. SEN
 - RS ROLLOUT SWITCH
 - SAT SUPPLY AIR TEMP. SEN
 - TB TERMINAL BLOCK
 - TRAN TRANSFORMER

APPENDIX I, MODEL NOMENCLATURE

MODEL SERIES	R	G	S	0	9	1	H	D	A	B	0	A	A	A	A
Position Number	1	2	3	4	5	6	7	8	9	10	11	12	13	14	15
R = Rooftop															
A = Air Conditioning (Cooling Only) H = Heat Pump G = Gas/Electric Type															
S = Standard ASHRAE 90.1-2010 Efficiency Efficiency															
036 = 36,000 = 3 Tons 048 = 48,000 = 4 Tons 060 = 60,000 = 5 Tons 072 = 72,000 = 6 Tons 091 = 90,000 = 7.5 Tons (Single Compressor) 101 = 102,000 = 8.5 Tons (Single Compressor) 121 = 120,000 = 10 Tons (Single Compressor) NOMINAL COOLING CAPACITY															
K = 208/230-1-60 H = 208/230-3-60 L = 460-3-60 S = 575-3-60 VOLTAGE															
D = :Low Heat E = Medium Heat F = High Heat L = Low Heat, Low NOx M = Medium Heat, Low NOx N = High Heat, Low NOx S = Low Heat, Stainless Steel Heat Xgr R = Medium Heat, Stainless Steel Heat Xgr T = High Heat, Stainless Steel Heat Xgr Heating Capacity (See spec sheet for actual capacity)															
A = Standard Motor B = High Static Motor Motor Option															
A = None B = Economizer w/Bara-relief, OA Temp sensor E = Economizer w/Bara-relief + CO2 Sensor, OA Temp sensor H = Economizer w/Bara-relief, enthalpy sensor L = Economizer w/Bara-relief + CO2 Sensor, enthalpy sensor P = 2-Position damper w/Baro-relief Outdoor Air Options / Control (See spec sheet for details)															
OA = No Options 4B = Non-Fused Disconnect AT = Non-powered 115v C.O. BR = Supply Air Smoke Detector 7C = Non-Fused Disconnect + Non-Powered 115v C.O. 7K = Non-Fused Disconnect + Non-Powered 115v C.O.+ SA Smoke detector 8A = Non-Fused Disconnect + SA Smoke detector Factory Installed Options															
A = Aluminum / Copper Cond & Evap Coil B = Precoat Alum/CU Cond II Alum / CU Evap C = E-Coated Alum/Cu Cond II Alum / CU Evap D = E-Coated Alum / Cu Cond & Evap F = Copper/Copper Cond & Evap Condenser / Evaporator Coil Configuration															
A = Initial Offering SALES DIGIT															
A = Standard A = Less than a truckload (LTL) UNIT PACKAGING															

APPENDIX II PHYSICAL DATA (COOLING) 3 - 6 TONS

		RGS036	RGS048	RGS060	RGS072
Refrigeration System					
# Circuits / # Comp. / Type		1 / 1 / Scroll	1 / 1 / Scroll	1 / 1 / Scroll	1 / 1 / Scroll
R-410A charge (lbs)		5.6	8.5	10.7	14.1
Oil (oz)		25	42	42	56
Metering Device			Fixed		
High-press. Trip / Reset (psig)		630 / 505	630 / 505	630 / 505	630 / 505
Low-press. Trip / Reset (psig)		54 / 117	54 / 117	54 / 117	54 / 117
Evap. Coil					
Material		Cu / Al	Cu / Al	Cu / Al	Cu / Al
Coil type		3/8" RTPF	3/8" RTPF	3/8" RTPF	3/8" RTPF
Rows / FPI		2 / 15	2 / 15	4 / 15	4 / 15
Total Face Area (ft ²)		5.5	5.5	5.5	7.3
Condensate Drain Conn. Size		3/4"	3/4"	3/4"	3/4"
Evap. Fan and Motor					
Standard Static 1 phase	Motor Qty / Drive Type	1 / Belt	1 / Belt	1 / Belt	—
	Max BHP	1.2	1.2	1.2	—
	RPM Range	560–854	560–854	770–1175	—
	Motor Frame Size	48	48	48	—
	Fan Qty / Type	1 / Centrifugal	1 / Centrifugal	1 / Centrifugal	—
	Fan Diameter (in)	10 x 10	10 x 10	10 x 10	—
Standard Static 3 phase	Motor Qty / Drive Type	1 / Belt	1 / Belt	1 / Belt	1 / Belt
	Max BHP	1.2	1.2	1.2	2.4
	RPM Range	560–854	560–854	770–1175	1073–1457
	Motor Frame Size	48	48	48	56
	Fan Qty / Type	1 / Centrifugal	1 / Centrifugal	1 / Centrifugal	1 / Centrifugal
	Fan Diameter (in)	10 x 10	10 x 10	10 x 10	10 x 10
High Static 1 phase	Motor Qty / Drive Type	1 / Belt	1 / Belt	1 / Belt	—
	Max BHP	1.2	1.2	1.5	—
	RPM Range	770–1175	770–1175	1035–1466	—
	Motor Frame Size	48	56	56	—
	Fan Qty / Type	1 / Centrifugal	1 / Centrifugal	1 / Centrifugal	—
	Fan Diameter (in)	10 x 10	10 x 10	10 x 10	—
High Static 3 phase	Motor Qty / Drive Type	1 / Belt	1 / Belt	1 / Belt	1 / Belt
	Max BHP	2.4	2.4	2.9	3.7
	RPM Range	1035–1466	1035–1466	1303–1687	1474–1788
	Motor Frame Size	56	56	56	56
	Fan Qty / Type	1 / Centrifugal	1 / Centrifugal	1 / Centrifugal	1 / Centrifugal
	Fan Diameter (in)	10 x 10	10 x 10	10 x 10	10 x 10
Cond. Coil					
Material		Cu / Al	Cu / Al	Cu / Al	Cu / Al
Coil type		3/8" RTPF	3/8" RTPF	3/8" RTPF	3/8" RTPF
Rows / FPI		1 / 17	2 / 17	2 / 17	2 / 17
Total Face Area (ft ²)		14.6	12.6	16.5	21.3
Cond. fan / motor					
Qty / Motor Drive Type		1/ Direct	1/ Direct	1/ Direct	1/ Direct
Motor HP / RPM		1/4 / 1100	1/4 / 1100	1/4 / 1100	1/4 / 1100
Fan diameter (in)		22	22	22	22
Filters					
RA Filter # / Size (in)		2 / 16 x 25 x 2	2 / 16 x 25 x 2	2 / 16 x 25 x 2	4 / 16 x 16 x 2
OA inlet screen # / Size (in)		1 / 20 x 24 x 1	1 / 20 x 24 x 1	1 / 20 x 24 x 1	1 / 20 x 24 x 1

APPENDIX II PHYSICAL DATA (HEATING) 3 - 6 TONS

		RGS036	RGS048	RGS060	RGS072
Gas Connection					
	# of Gas Valves	1	1	1	1
	Nat. gas supply line press (in. w.g.)/(PSIG)	4-13 / 0.18-0.47	4-13 / 0.18-0.47	4-13 / 0.18-0.47	4-13 / 0.18-0.47
	LP supply line press (in. w.g.)/(PSIG)	11-13 / 0.40-0.47	11-13 / 0.40-0.47	11-13 / 0.40-0.47	11-13 / 0.40-0.47
Heat Anticipator Setting (Amps)					
	1st stage	0.14	0.14	0.14	0.14
	2nd stage	0.14	0.14	0.14	0.14
Natural Gas Heat					
LOW	Connection size	1/2" NPT	1/2" NPT	1/2" NPT	1/2" NPT
	# of stages / # of burners (total)	1 / 2	1 / 2	1 / 2	1 / 2
	Rollout switch opens / Closes	195 / 115	195 / 115	195 / 115	195 / 115
	Temperature rise (min/max)	25 / 55	25 - 55	25 - 55	25 - 55
MED	Connection size	1/2" NPT	1/2" NPT	1/2" NPT	1/2" NPT
	# of stages / # of burners (total)	1 or 2 / 3	1 / 3	1 / 3	1 / 3
	Rollout switch opens / Closes	195 / 115	195 / 115	195 / 115	195 / 115
	Temperature rise (min/max)	55 / 85	35 / 65	35 / 65	35 / 65
HIGH	Connection size	1/2" NPT	1/2" NPT	1/2" NPT	1/2" NPT
	# of stages / # of burners (total)	-	1 or 2 / 3	1 or 2 / 3	1 or 2 / 3
	Rollout switch opens / Closes	-	195 / 115	195 / 115	195 / 115
	Temperature rise (min/max)	-	50 / 80	50 / 80	50 / 80
Liquid Propane Heat					
LOW	Connection size	1/2" NPT	1/2" NPT	1/2" NPT	1/2" NPT
	# of stages / # of burners (total)	1 / 2	1 / 2	1 / 2	1 / 2
	Rollout switch opens / Closes	195 / 115	195 / 115	195 / 115	195 / 115
	Temperature rise (min/max)	25 / 55	25 - 55	25 - 55	25 - 55
MED	Connection size	1/2" NPT	1/2" NPT	1/2" NPT	1/2" NPT
	# of stages / # of burners (total)	1 or 2 / 3	1 or 2 / 3	1 or 2 / 3	1 or 2 / 3
	Rollout switch opens / Closes	195 / 115	195 / 115	195 / 115	195 / 115
	Temperature rise (min/max)	55 / 85	35 / 65	35 / 65	35 / 65
HIGH	Connection size	1/2" NPT	1/2" NPT	1/2" NPT	1/2" NPT
	# of stages / # of burners (total)	-	1 or 2 / 3	1 or 2 / 3	1 or 2 / 3
	Rollout switch opens / Closes	-	195 / 115	195 / 115	195 / 115
	Temperature rise (min/max)	-	50 / 80	50 / 80	50 / 80
Low NO_x Gas Heat					
LOW	Connection size	1/2" NPT	1/2" NPT	1/2" NPT	1/2" NPT
	# of stages / # of burners (total)	1 / 2	1 / 2	1 / 2	-
	Rollout switch opens / Closes	195 / 115	195 / 115	195 / 115	-
	Temperature rise (min/max)	20 / 50	20 / 50	20 / 50	-
MED	Connection size	1/2" NPT	1/2" NPT	1/2" NPT	1/2" NPT
	# of stages / # of burners (total)	1 / 3	1 / 3	1 / 3	-
	Rollout switch opens / closes	195 / 115	195 / 115	195 / 115	-
	Temperature rise (min/max)	30 / 60	30 / 60	30 / 60	-
HIGH	Connection size	1/2" NPT	1/2" NPT	1/2" NPT	1/2" NPT
	# of stages / # of burners (total)	-	1 / 3	1 / 3	-
	Rollout switch opens / Closes	-	195 / 115	195 / 115	-
	Temperature rise (min/max)	-	40 / 70	40 / 70	-

APPENDIX II PHYSICAL DATA (COOLING) 7.5 - 10 TONS

		RGS091	RGS101	RGS121
Refrigeration System				
	# Circuits / # Comp. / Type	1 / 1 / Scroll	1 / 1 / Scroll	1 / 1 / Scroll
	R-410A charge (lbs)	13.75	15.25	20.0
	Oil (oz)	60	85	110
	Metering Device		Fixed Metering Device	
	High-press. Trip / Reset (psig)	630 / 505	630 / 505	630 / 505
	Low-press. Trip / Reset (psig)	54 / 117	54 / 117	54 / 117
Evap. Coil				
	Material	Cu / Al	Cu / Al	Cu / Al
	Coil type	3/8" RTPF	3/8" RTPF	3/8" RTPF
	Rows / FPI	3 / 15	3 / 15	4 / 15
	Total Face Area (ft ²)	8.9	11.1	11.1
	Condensate Drain Conn. Size	3/4"	3/4"	3/4"
Evap. Fan and Motor				
Standard Static 3 phase	Motor Qty / Drive Type	1 / Belt	1 / Belt	1 / Belt
	Max BHP	1.7	1.7	2.4
	RPM Range	489-747	518-733	591-838
	Motor Frame Size	56	56	56
	Fan Qty / Type	1 / Centrifugal	1 / Centrifugal	1 / Centrifugal
	Fan Diameter (in)	15 x 15	15 x 15	15 x 15
High Static 3 phase	Motor Qty / Drive Type	1 / Belt	1 / Belt	1 / Belt
	Max BHP	5.25	3.7	5.25
	RPM Range	909-1102	838-1084	1022-1240
	Motor Frame Size	145TY	56	145TY
	Fan Qty / Type	1 / Centrifugal	1 / Centrifugal	1 / Centrifugal
	Fan Diameter (in)	15 x 15	15 x 15	15 x 15
Cond. Coil				
	Material	Cu / Al	Cu / Al	Cu / Al
	Coil type	3/8" RTPF	3/8" RTPF	3/8" RTPF
	Rows / FPI	2 / 17	2 / 17	2 / 17
	Total Face Area (ft ²)	20.5	21.4	25.1
Cond. fan / motor				
	Qty / Motor Drive Type	2 / Direct	2 / Direct	2 / Direct
	Motor HP / RPM	1/4 / 1100	1/4 / 1100	1/4 / 1100
	Fan diameter (in)	22	22	22
Filters				
	RA Filter # / Size (in)	4 / 16 x 20 x 2	4 / 20 x 20 x 2	4 / 20 x 20 x 2
	OA inlet screen # / Size (in)	1 / 20 x 24 x 1	1 / 20 x 24 x 1	1 / 20 x 24 x 1

APPENDIX II PHYSICAL DATA (HEATING) 7.5 - 10 TONS

		RGS091	RGS101	RGS121
Gas Connection				
	# of Gas Valves	1	1	1
	Nat. gas supply line press (in. w.g.)/(PSIG)	4-13 / 0.18-0.47	4-13 / 0.18-0.47	4-13 / 0.18-0.47
	LP supply line press (in. w.g.)/(PSIG)	11-13 / 0.40-0.47	11-13 / 0.40-0.47	11-13 / 0.40-0.47
Heat Anticipator Setting (Amps)				
	1st stage	0.14	0.14	0.14
	2nd stage	0.14	0.14	0.14
Natural Gas Heat				
LOW	Connection size	1/2" NPT	1/2" NPT	3/4" NPT
	# of stages / # of burners (total)	1 / 3	1 / 3	2 / 4
	Rollout switch opens / Closes	195 / 115	195 / 115	195 / 115
	Temperature rise (min/max)	20 / 50	20 / 50	20 / 50
MED	Connection size	3/4" NPT	3/4" NPT	3/4" NPT
	# of stages / # of burners (total)	2 / 4	2 / 4	2 / 5
	Rollout switch opens / Closes	195 / 115	195 / 115	195 / 115
	Temperature rise (min/max)	35 / 685	35 / 65	45 / 75
HIGH	Connection size	3/4" NPT	3/4" NPT	3/4" NPT
	# of stages / # of burners (total)	2 / 5	2 / 5	2 / 5
	Rollout switch opens / Closes	195 / 115	195 / 115	195 / 115
	Temperature rise (min/max)	45 / 75	45 / 75	40 / 70
Liquid Propane Heat				
LOW	Connection size	1/2" NPT	1/2" NPT	3/4" NPT
	# of stages / # of burners (total)	2 / 3	2 / 3	2 / 3
	Rollout switch opens / Closes	195 / 115	195 / 115	195 / 115
	Temperature rise (min/max)	20 / 50	20 / 50	35 / 65
MED	Connection size	3/4" NPT	3/4" NPT	3/4" NPT
	# of stages / # of burners (total)	2 / 4	2 / 4	2 / 5
	Rollout switch opens / Closes	195 / 115	195 / 115	195 / 115
	Temperature rise (min/max)	35 / 65	35 / 65	45 / 75
HIGH	Connection size	3/4" NPT	3/4" NPT	3/4" NPT
	# of stages / # of burners (total)	2 / 5	2 / 5	2 / 5
	Rollout switch opens / Closes	195 / 115	195 / 115	195 / 115
	Temperature rise (min/max)	45 / 75	45 / 75	40 / 70

General fan performance notes:

9. Interpolation is permissible. Do not extrapolate.
10. External static pressure is the static pressure difference between the return duct and the supply duct plus the static pressure caused by any FIOPs or accessories.
11. Tabular data accounts for pressure loss due to clean filters, unit casing, and wet coils. Factory options and accessories may add static pressure losses, as shown in Table 18. Selection software is available, through your salesperson, to help you select the best motor/drive combination for your application.
12. The Fan Performance tables offer motor/drive recommendations. In cases when two motor/drive combinations would work, recommend the lower horsepower option.
13. For information on the electrical properties of motors, please see the Electrical information section of this book.
14. For more information on the performance limits of motors, see the application data section of this book.

APPENDIX III FAN PERFORMANCE - RGS036, 1 PHASE, 3 TON HORIZONTAL SUPPLY

CFM	AVAILABLE EXTERNAL STATIC PRESSURE (in. wg)									
	0.2		0.4		0.6		0.8		1.0	
	RPM	BHP	RPM	BHP	RPM	BHP	RPM	BHP	RPM	BHP
	Field-Supplied Drive ¹		Standard Static Option				High Static Option			
900	553	0.14	681	0.22	782	0.32	870	0.42	948	0.53
975	575	0.16	700	0.25	801	0.35	888	0.46	965	0.57
1050	597	0.18	720	0.28	820	0.38	906	0.49	983	0.61
1125	620	0.21	741	0.31	839	0.42	925	0.54	1001	0.66
1200	643	0.23	762	0.34	859	0.46	944	0.58	1020	0.71
1275	667	0.27	783	0.38	879	0.50	963	0.63	1038	0.76
1350	691	0.30	805	0.42	900	0.55	983	0.68	1057	0.82
1425	715	0.34	827	0.47	920	0.60	1002	0.74	1076	0.88
1500	740	0.38	849	0.52	941	0.66	1023	0.80	1096	0.95

CFM	AVAILABLE EXTERNAL STATIC PRESSURE (in. wg)									
	1.2		1.4		1.6		1.8		2.0	
	RPM	BHP	RPM	BHP	RPM	BHP	RPM	BHP	RPM	BHP
	High Static Option					Field-Supplied Drive ²				
900	1019	0.64	1084	0.76	1146	0.89	1203	1.02	1258	1.16
975	1036	0.69	1101	0.81	1162	0.94	1219	1.08	-	-
1050	1053	0.74	1118	0.86	1179	1.00	1236	1.14	-	-
1125	1071	0.79	1135	0.92	1196	1.06	1253	1.20	-	-
1200	1089	0.84	1153	0.98	1213	1.12	-	-	-	-
1275	1107	0.90	1171	1.04	1231	1.19	-	-	-	-
1350	1126	0.96	1189	1.11	-	-	-	-	-	-
1425	1144	1.03	1208	1.18	-	-	-	-	-	-
1500	1163	1.10	-	-	-	-	-	-	-	-

NOTE: For more information, see General Fan Performance Notes on page 47.

Boldface indicates field-supplied drive is required.

1. Recommend using field-supplied fan pulley (part number KR11AG006) and belt (part number KR30AE039).
2. Recommend using field-supplied motor pulley (part number KR11HY161) and belt (part number KR30AE035).

APPENDIX III FAN PERFORMANCE - RGS036, 1 PHASE, 3 TON VERTICAL SUPPLY

CFM	AVAILABLE EXTERNAL STATIC PRESSURE (in. wg)									
	0.2		0.4		0.6		0.8		1.0	
	RPM	BHP	RPM	BHP	RPM	BHP	RPM	BHP	RPM	BHP
	Field-Supplied Drive ¹		Standard Static Option				High Static Option			
900	567	0.15	688	0.22	786	0.30	871	0.37	947	0.44
975	591	0.17	710	0.26	807	0.34	891	0.42	966	0.49
1050	615	0.20	732	0.29	828	0.38	911	0.47	985	0.55
1125	641	0.23	755	0.33	849	0.42	931	0.52	1005	0.61
1200	666	0.26	778	0.37	871	0.47	952	0.57	1025	0.67
1275	693	0.29	802	0.41	893	0.53	974	0.63	1046	0.74
1350	719	0.33	826	0.46	916	0.58	995	0.70	1067	0.81
1425	746	0.38	850	0.51	939	0.64	1017	0.76	1088	0.89
1500	773	0.42	875	0.57	963	0.70	1040	0.84	1110	0.96

CFM	AVAILABLE EXTERNAL STATIC PRESSURE (in. wg)									
	1.2		1.4		1.6		1.8		2.0	
	RPM	BHP	RPM	BHP	RPM	BHP	RPM	BHP	RPM	BHP
	High Static Option					Field-Supplied Drive ²				
900	1016	0.51	1080	0.57	1139	0.64	1195	0.71	1249	0.77
975	1034	0.57	1098	0.64	1157	0.72	1213	0.79	1266	0.86
1050	1053	0.63	1116	0.71	1176	0.79	1231	0.87	1284	0.95
1125	1073	0.70	1135	0.79	1194	0.87	1250	0.96	1302	1.04
1200	1093	0.77	1155	0.87	1213	0.96	1268	1.05	1321	1.14
1275	1113	0.85	1174	0.95	1232	1.05	1287	1.15	-	-
1350	1133	0.92	1194	1.03	1252	1.14	-	-	-	-
1425	1154	1.01	1215	1.12	-	-	-	-	-	-
1500	1175	1.09	-	-	-	-	-	-	-	-

NOTE: For more information, see General Fan Performance Notes on page 47.

Boldface indicates field-supplied drive is required.

1. Recommend using field-supplied fan pulley (part number KR11AG006) and belt (part number KR30AE039).
2. Recommend using field-supplied motor pulley (part number KR11HY161) and belt (part number KR30AE035).

APPENDIX III FAN PERFORMANCE - RGS036, 3 PHASE, 3 TON HORIZONTAL SUPPLY

CFM	AVAILABLE EXTERNAL STATIC PRESSURE (in. wg)									
	0.2		0.4		0.6		0.8		1.0	
	RPM	BHP	RPM	BHP	RPM	BHP	RPM	BHP	RPM	BHP
	Field-Supplied Drive¹		Standard Static Option				High Static Option with Field Supplied Drive²			
900	553	0.14	681	0.22	782	0.32	870	0.42	948	0.53
975	575	0.16	700	0.25	801	0.35	888	0.46	965	0.57
1050	597	0.18	720	0.28	820	0.38	906	0.49	983	0.61
1125	620	0.21	741	0.31	839	0.42	925	0.54	1001	0.66
1200	643	0.23	762	0.34	859	0.46	944	0.58	1020	0.71
1275	667	0.27	783	0.38	879	0.50	963	0.63	1038	0.76
1350	691	0.30	805	0.42	900	0.55	983	0.68	1057	0.82
1425	715	0.34	827	0.47	920	0.60	1002	0.74	1076	0.88
1500	740	0.38	849	0.52	941	0.66	1023	0.80	1096	0.95

CFM	AVAILABLE EXTERNAL STATIC PRESSURE (in. wg)									
	1.2		1.4		1.6		1.8		2.0	
	RPM	BHP	RPM	BHP	RPM	BHP	RPM	BHP	RPM	BHP
	High Static Option with Field Supplied Drive²					High Static Option				
900	1019	0.64	1084	0.76	1146	0.89	1203	1.02	1258	1.16
975	1036	0.69	1101	0.81	1162	0.94	1219	1.08	1274	1.22
1050	1053	0.74	1118	0.86	1179	1.00	1236	1.14	1290	1.28
1125	1071	0.79	1135	0.92	1196	1.06	1253	1.20	1307	1.35
1200	1089	0.84	1153	0.98	1213	1.12	1270	1.27	1324	1.42
1275	1107	0.90	1171	1.04	1231	1.19	1287	1.34	1341	1.50
1350	1126	0.96	1189	1.11	1249	1.26	1305	1.42	1358	1.58
1425	1144	1.03	1208	1.18	1267	1.34	1323	1.50	1376	1.66
1500	1163	1.10	1226	1.25	1285	1.41	1341	1.58	1394	1.75

NOTE: For more information, see General Fan Performance Notes on page 47.

1. Recommend using field-supplied blower pulley (part number KR11AG006) and belt (part number KR30AE039)
2. Recommend using field-supplied motor pulley (part number KR11HY151 -208/230 & 460V, part number KR11HY150 - 575V) and belt (part number KR29AF035)

APPENDIX III FAN PERFORMANCE - RGS036, 3 PHASE, 3 TON VERTICAL SUPPLY

CFM	AVAILABLE EXTERNAL STATIC PRESSURE (in. wg)									
	0.2		0.4		0.6		0.8		1.0	
	RPM	BHP	RPM	BHP	RPM	BHP	RPM	BHP	RPM	BHP
	Field-Supplied Drive¹		Standard Static Option				High Static Option with Field Supplied Drive²			
900	567	0.15	688	0.22	786	0.30	871	0.37	947	0.44
975	591	0.17	710	0.26	807	0.34	891	0.42	966	0.49
1050	615	0.20	732	0.29	828	0.38	911	0.47	985	0.55
1125	641	0.23	755	0.33	849	0.42	931	0.52	1005	0.61
1200	666	0.26	778	0.37	871	0.47	952	0.57	1025	0.67
1275	693	0.29	802	0.41	893	0.53	974	0.63	1046	0.74
1350	719	0.33	826	0.46	916	0.58	995	0.70	1067	0.81
1425	746	0.38	850	0.51	939	0.64	1017	0.76	1088	0.89
1500	773	0.42	875	0.57	963	0.70	1040	0.84	1110	0.96

CFM	AVAILABLE EXTERNAL STATIC PRESSURE (in. wg)									
	1.2		1.4		1.6		1.8		2.0	
	RPM	BHP	RPM	BHP	RPM	BHP	RPM	BHP	RPM	BHP
	High Static Option with Field Supplied Drive²					High Static Option				
900	1016	0.51	1080	0.57	1139	0.64	1195	0.71	1249	0.77
975	1034	0.57	1098	0.64	1157	0.72	1213	0.79	1266	0.86
1050	1053	0.63	1116	0.71	1176	0.79	1231	0.87	1284	0.95
1125	1073	0.70	1135	0.79	1194	0.87	1250	0.96	1302	1.04
1200	1093	0.77	1155	0.87	1213	0.96	1268	1.05	1321	1.14
1275	1113	0.85	1174	0.95	1232	1.05	1287	1.15	1339	1.25
1350	1133	0.92	1194	1.03	1252	1.14	1307	1.25	1358	1.35
1425	1154	1.01	1215	1.12	1272	1.24	1326	1.35	1378	1.46
1500	1175	1.09	1235	1.22	1292	1.34	1346	1.46	1397	1.58

NOTE: For more information, see General Fan Performance Notes on page 47.

Boldface indicates field-supplied drive is required.

1. Recommend using field-supplied blower pulley (part number KR11AG006) and belt (part number KR30AE039)
2. Recommend using field-supplied motor pulley (part number KR11HY151 -208/230 & 460V, part number KR11HY150 - 575V) and belt (part number KR29AF035)

APPENDIX III FAN PERFORMANCE - RGS048, 1 PHASE, 4 TON HORIZONTAL SUPPLY

CFM	AVAILABLE EXTERNAL STATIC PRESSURE (in. wg)									
	0.2		0.4		0.6		0.8		1.0	
	RPM	BHP	RPM	BHP	RPM	BHP	RPM	BHP	RPM	BHP
	Standard Static Option					High Static Option				
1200	643	0.23	762	0.34	859	0.46	944	0.58	1020	0.71
1300	675	0.28	790	0.40	886	0.52	969	0.65	1044	0.78
1400	707	0.33	819	0.45	913	0.58	996	0.72	1070	0.86
1500	740	0.38	849	0.52	941	0.66	1023	0.80	1096	0.95
1600	773	0.45	879	0.59	970	0.73	1050	0.88	1123	1.04
1700	807	0.52	910	0.67	999	0.82	1078	0.98	1150	1.14
1800	841	0.59	942	0.75	1029	0.91	1106	1.08	1177	1.25
1900	875	0.68	974	0.85	1059	1.02	1135	1.19	1205	1.37
2000	910	0.77	1006	0.95	1090	1.13	1165	1.31	1234	1.49

CFM	AVAILABLE EXTERNAL STATIC PRESSURE (in. wg)									
	1.2		1.4		1.6		1.8		2.0	
	RPM	BHP	RPM	BHP	RPM	BHP	RPM	BHP	RPM	BHP
	High Static Option					Field-Supplied Drive ¹				
1200	1089	0.84	1153	0.98	1213	1.12	-	-	-	-
1300	1113	0.92	1177	1.06	-	-	-	-	-	-
1400	1138	1.01	1201	1.15	-	-	-	-	-	-
1500	1163	1.10	-	-	-	-	-	-	-	-
1600	1189	1.20	-	-	-	-	-	-	-	-
1700	-	-	-	-	-	-	-	-	-	-
1800	-	-	-	-	-	-	-	-	-	-
1900	-	-	-	-	-	-	-	-	-	-
2000	-	-	-	-	-	-	-	-	-	-

NOTE: For more information, see General Fan Performance Notes on page 47.

Boldface indicates field-supplied drive is required.

1. Recommend using field-supplied blower pulley (part number KR11HY161) and belt (part number KR30AE035)

APPENDIX III FAN PERFORMANCE - RGS048, 1 PHASE, 4 TON VERTICAL SUPPLY

CFM	AVAILABLE EXTERNAL STATIC PRESSURE (in. wg)									
	0.2		0.4		0.6		0.8		1.0	
	RPM	BHP	RPM	BHP	RPM	BHP	RPM	BHP	RPM	BHP
	Standard Static Option					High Static Option				
1200	666	0.26	778	0.37	871	0.47	952	0.57	1025	0.67
1300	701	0.31	810	0.43	901	0.54	981	0.65	1053	0.76
1400	737	0.36	842	0.49	931	0.62	1010	0.74	1081	0.86
1500	773	0.42	875	0.57	963	0.70	1040	0.84	1110	0.96
1600	810	0.49	909	0.65	994	0.79	1070	0.94	1140	1.08
1700	847	0.57	943	0.73	1027	0.89	1101	1.05	1170	1.20
1800	885	0.66	978	0.83	1060	1.00	1133	1.16	1200	1.32
1900	923	0.75	1014	0.94	1093	1.11	1165	1.29	1231	1.46
2000	962	0.85	1049	1.05	1127	1.24	1198	1.42	1263	1.61

CFM	AVAILABLE EXTERNAL STATIC PRESSURE (in. wg)									
	1.2		1.4		1.6		1.8		2.0	
	RPM	BHP	RPM	BHP	RPM	BHP	RPM	BHP	RPM	BHP
	High Static Option					Field-Supplied Drive ¹				
1200	1093	0.77	1155	0.87	1213	0.96	1268	1.05	1321	1.14
1300	1119	0.87	1181	0.98	1239	1.08	1294	1.18	-	-
1400	1147	0.98	1208	1.09	-	-	-	-	-	-
1500	1175	1.09	-	-	-	-	-	-	-	-
1600	-	-	-	-	-	-	-	-	-	-
1700	-	-	-	-	-	-	-	-	-	-
1800	-	-	-	-	-	-	-	-	-	-
1900	-	-	-	-	-	-	-	-	-	-
2000	-	-	-	-	-	-	-	-	-	-

NOTE: For more information, see General Fan Performance Notes on page 47.

Boldface indicates field-supplied drive is required.

1. Recommend using field-supplied blower pulley (part number KR11HY161) and belt (part number KR30AE035)

APPENDIX III FAN PERFORMANCE - RGS048, 3 PHASE, 4 TON HORIZONTAL SUPPLY

CFM	AVAILABLE EXTERNAL STATIC PRESSURE (in. wg)									
	0.2		0.4		0.6		0.8		1.0	
	RPM	BHP	RPM	BHP	RPM	BHP	RPM	BHP	RPM	BHP
	Standard Static Option					High Static Option with Field Supplied Drive ²				
1200	643	0.23	762	0.34	859	0.46	944	0.58	1020	0.71
1300	675	0.28	790	0.40	886	0.52	969	0.65	1044	0.78
1400	707	0.33	819	0.45	913	0.58	996	0.72	1070	0.86
1500	740	0.38	849	0.52	941	0.66	1023	0.80	1096	0.95
1600	773	0.45	879	0.59	970	0.73	1050	0.88	1123	1.04
1700	807	0.52	910	0.67	999	0.82	1078	0.98	1150	1.14
1800	841	0.59	942	0.75	1029	0.91	1106	1.08	1177	1.25
1900	875	0.68	974	0.85	1059	1.02	1135	1.19	1205	1.37
2000	910	0.77	1006	0.95	1090	1.13	1165	1.31	1234	1.49

CFM	AVAILABLE EXTERNAL STATIC PRESSURE (in. wg)									
	1.2		1.4		1.6		1.8		2.0	
	RPM	BHP	RPM	BHP	RPM	BHP	RPM	BHP	RPM	BHP
	High Static Option with Field Supplied Drive ²					High Static Option				
1200	1089	0.84	1153	0.98	1213	1.12	1270	1.27	1324	1.42
1300	1113	0.92	1177	1.06	1237	1.21	1293	1.36	1347	1.52
1400	1138	1.01	1201	1.15	1261	1.31	1317	1.47	1370	1.63
1500	1163	1.10	1226	1.25	1285	1.41	1341	1.58	1394	1.75
1600	1189	1.20	1252	1.36	1310	1.53	1365	1.70	1418	1.87
1700	1216	1.31	1277	1.48	1335	1.65	1390	1.83	1442	2.01
1800	1242	1.42	1303	1.60	1361	1.78	1415	1.96	1467	2.15
1900	1270	1.55	1330	1.73	1387	1.92	1441	2.11	1493	2.30
2000	1297	1.68	1357	1.87	1414	2.07	1467	2.26	-	-

NOTE: For more information, see General Fan Performance Notes on page 47.

Boldface indicates field-supplied drive is required.

1. Recommend using field-supplied blower pulley (part no. KR11AZ506), motor pulley (part no. KR11HY181) and belt (part no. KR30AE041).
2. Recommend using field-supplied motor pulley (part number KR11HY151 -208/230 & 460V, part number KR11HY150 - 575V) and belt (part number KR29AF035).

APPENDIX III FAN PERFORMANCE - RGS048, 3 PHASE, 4 TON VERTICAL SUPPLY

CFM	AVAILABLE EXTERNAL STATIC PRESSURE (in. wg)									
	0.2		0.4		0.6		0.8		1.0	
	RPM	BHP	RPM	BHP	RPM	BHP	RPM	BHP	RPM	BHP
	Standard Static Option					High Static Option with Field Supplied Drive ²				
1200	666	0.26	778	0.37	871	0.47	952	0.57	1025	0.67
1300	701	0.31	810	0.43	901	0.54	981	0.65	1053	0.76
1400	737	0.36	842	0.49	931	0.62	1010	0.74	1081	0.86
1500	773	0.42	875	0.57	963	0.70	1040	0.84	1110	0.96
1600	810	0.49	909	0.65	994	0.79	1070	0.94	1140	1.08
1700	847	0.57	943	0.73	1027	0.89	1101	1.05	1170	1.20
1800	885	0.66	978	0.83	1060	1.00	1133	1.16	1200	1.32
1900	923	0.75	1014	0.94	1093	1.11	1165	1.29	1231	1.46
2000	962	0.85	1049	1.05	1127	1.24	1198	1.42	1263	1.61

CFM	AVAILABLE EXTERNAL STATIC PRESSURE (in. wg)									
	1.2		1.4		1.6		1.8		2.0	
	RPM	BHP	RPM	BHP	RPM	BHP	RPM	BHP	RPM	BHP
	High Static Option with Field Supplied Drive ²					High Static Option				
1200	1093	0.77	1155	0.87	1213	0.96	1268	1.05	1321	1.14
1300	1119	0.87	1181	0.98	1239	1.08	1294	1.18	1346	1.28
1400	1147	0.98	1208	1.09	1265	1.21	1320	1.32	1371	1.43
1500	1175	1.09	1235	1.22	1292	1.34	1346	1.46	1397	1.58
1600	1204	1.21	1263	1.35	1320	1.48	1373	1.61	1424	1.74
1700	1233	1.34	1292	1.49	1348	1.63	1401	1.77	1451	1.91
1800	1262	1.48	1321	1.64	1376	1.79	1428	1.94	1479	2.09
1900	1293	1.63	1350	1.79	1405	1.96	1457	2.12	1506	2.28
2000	1323	1.79	1380	1.96	1434	2.13	1486	2.31	-	-

NOTE: For more information, see General Fan Performance Notes on page 47.

Boldface indicates field-supplied drive is required.

1. Recommend using field-supplied blower pulley (part no. KR11AZ506), motor pulley (part no. KR11HY181) and belt (part no. KR30AE041).
2. Recommend using field-supplied motor pulley (part number KR11HY151 -208/230 & 460V, part number KR11HY150 - 575V) and belt (part number KR29AF035).

APPENDIX III FAN PERFORMANCE - RGS060, 1 PHASE, 5 TON HORIZONTAL SUPPLY

CFM	AVAILABLE EXTERNAL STATIC PRESSURE (in. wg)									
	0.2		0.4		0.6		0.8		1.0	
	RPM	BHP	RPM	BHP	RPM	BHP	RPM	BHP	RPM	BHP
	Standard Static Option								High Static Option	
1500	800	0.39	904	0.49	999	0.60	1087	0.72	1169	0.85
1625	849	0.48	947	0.59	1038	0.70	1122	0.83	1201	0.96
1750	899	0.59	992	0.70	1078	0.82	1159	0.95	1235	1.08
1875	950	0.70	1038	0.82	1120	0.95	1198	1.08	1271	1.22
2000	1001	0.84	1085	0.96	1163	1.09	1238	1.23	1309	1.38
2125	1053	0.99	1133	1.12	1208	1.26	1280	1.40	-	-
2250	1106	1.16	1182	1.29	1254	1.44	-	-	-	-
2375	1159	1.34	1231	1.49	-	-	-	-	-	-
2500	-	-	-	-	-	-	-	-	-	-

CFM	AVAILABLE EXTERNAL STATIC PRESSURE (in. wg)									
	1.2		1.4		1.6		1.8		2.0	
	RPM	BHP	RPM	BHP	RPM	BHP	RPM	BHP	RPM	BHP
	High Static Option									
1500	1247	0.98	1320	1.13	1390	1.28	1457	1.44	-	-
1625	1276	1.10	1348	1.24	1416	1.40	-	-	-	-
1750	1308	1.22	1377	1.38	-	-	-	-	-	-
1875	1342	1.37	-	-	-	-	-	-	-	-
2000	-	-	-	-	-	-	-	-	-	-
2125	-	-	-	-	-	-	-	-	-	-
2250	-	-	-	-	-	-	-	-	-	-
2375	-	-	-	-	-	-	-	-	-	-
2500	-	-	-	-	-	-	-	-	-	-

NOTE: For more information, see General Fan Performance Notes on page 47.
Boldface indicates field-supplied drive is required.

APPENDIX III FAN PERFORMANCE - RGS060, 1 PHASE, 5 TON VERTICAL SUPPLY

CFM	AVAILABLE EXTERNAL STATIC PRESSURE (in. wg)									
	0.2		0.4		0.6		0.8		1.0	
	RPM	BHP	RPM	BHP	RPM	BHP	RPM	BHP	RPM	BHP
	Standard Static Option								High Static Option	
1500	848	0.42	968	0.55	1069	0.68	1158	0.80	1238	0.94
1625	897	0.51	1013	0.65	1111	0.79	1198	0.93	1277	1.07
1750	947	0.61	1059	0.76	1155	0.91	1240	1.06	1318	1.21
1875	997	0.72	1105	0.89	1199	1.05	1283	1.21	1359	1.37
2000	1048	0.85	1153	1.03	1244	1.20	1326	1.37	-	-
2125	1100	1.00	1201	1.19	1290	1.37	-	-	-	-
2250	1152	1.16	1250	1.36	-	-	-	-	-	-
2375	1205	1.34	-	-	-	-	-	-	-	-
2500	-	-	-	-	-	-	-	-	-	-

CFM	AVAILABLE EXTERNAL STATIC PRESSURE (in. wg)									
	1.2		1.4		1.6		1.8		2.0	
	RPM	BHP	RPM	BHP	RPM	BHP	RPM	BHP	RPM	BHP
	High Static Option								Field-Supplied Drive ¹	
1500	1312	1.07	1380	1.20	1445	1.34	1506	1.48	-	-
1625	1350	1.21	1418	1.35	1482	1.50	-	-	-	-
1750	1390	1.36	-	-	-	-	-	-	-	-
1875	-	-	-	-	-	-	-	-	-	-
2000	-	-	-	-	-	-	-	-	-	-
2125	-	-	-	-	-	-	-	-	-	-
2250	-	-	-	-	-	-	-	-	-	-
2375	-	-	-	-	-	-	-	-	-	-
2500	-	-	-	-	-	-	-	-	-	-

NOTE: For more information, see General Fan Performance Notes on page 47.
Boldface indicates field-supplied drive is required.
 1. Recommend using field-supplied motor pulley (part number KR11HY171) and belt (part number KR30AE039).

APPENDIX III FAN PERFORMANCE - RGS060, 3 PHASE, 5 TON HORIZONTAL SUPPLY

CFM	AVAILABLE EXTERNAL STATIC PRESSURE (in. wg)									
	0.2		0.4		0.6		0.8		1.0	
	RPM	BHP	RPM	BHP	RPM	BHP	RPM	BHP	RPM	BHP
	Standard Static Option								High Static Option with Field Supplied Drive ¹	
1500	800	0.39	904	0.49	999	0.60	1087	0.72	1169	0.85
1625	849	0.48	947	0.59	1038	0.70	1122	0.83	1201	0.96
1750	899	0.59	992	0.70	1078	0.82	1159	0.95	1235	1.08
1875	950	0.70	1038	0.82	1120	0.95	1198	1.08	1271	1.22
2000	1001	0.84	1085	0.96	1163	1.09	1238	1.23	1309	1.38
2125	1053	0.99	1133	1.12	1208	1.26	1280	1.40	1348	1.55
2250	1106	1.16	1182	1.29	1254	1.44	1323	1.59	1389	1.74
2375	1159	1.34	1231	1.49	1300	1.64	1367	1.80	1430	1.96
2500	1212	1.55	1281	1.70	1348	1.86	1412	2.02	1473	2.19

CFM	AVAILABLE EXTERNAL STATIC PRESSURE (in. wg)									
	1.2		1.4		1.6		1.8		2.0	
	RPM	BHP	RPM	BHP	RPM	BHP	RPM	BHP	RPM	BHP
	High Static Option with Field Supplied Drive ¹								High Static Option	
1500	1247	0.98	1320	1.13	1390	1.28	1457	1.44	1522	1.61
1625	1276	1.10	1348	1.24	1416	1.40	1481	1.56	1544	1.73
1750	1308	1.22	1377	1.38	1444	1.53	1507	1.70	1569	1.87
1875	1342	1.37	1409	1.52	1473	1.69	1536	1.86	1596	2.03
2000	1377	1.53	1442	1.69	1505	1.86	1565	2.03	1624	2.21
2125	1414	1.71	1477	1.87	1538	2.04	1597	2.22	1654	2.40
2250	1452	1.91	1514	2.08	1573	2.25	1630	2.43	1686	2.62
2375	1492	2.12	1551	2.30	1609	2.48	1665	2.66	1719	2.85
2500	1533	2.36	1591	2.54	1647	2.73	-	-	-	-

NOTE: For more information, see General Fan Performance Notes on page 47.

Boldface indicates field-supplied drive is required.

1. Recommend using field-supplied motor pulley (part number KR11HY161) blower pulley (part no. KR11AZ406), and belt (part number KR29AF038)

APPENDIX III FAN PERFORMANCE - RGS060, 3 PHASE, 5 TON VERTICAL SUPPLY

CFM	AVAILABLE EXTERNAL STATIC PRESSURE (in. wg)									
	0.2		0.4		0.6		0.8		1.0	
	RPM	BHP	RPM	BHP	RPM	BHP	RPM	BHP	RPM	BHP
	Standard Static Option						High Static Option with Field Supplied Drive ¹			
1500	848	0.42	968	0.55	1069	0.68	1158	0.80	1238	0.94
1625	897	0.51	1013	0.65	1111	0.79	1198	0.93	1277	1.07
1750	947	0.61	1059	0.76	1155	0.91	1240	1.06	1318	1.21
1875	997	0.72	1105	0.89	1199	1.05	1283	1.21	1359	1.37
2000	1048	0.85	1153	1.03	1244	1.20	1326	1.37	1401	1.54
2125	1100	1.00	1201	1.19	1290	1.37	1370	1.55	1444	1.73
2250	1152	1.16	1250	1.36	1336	1.55	1415	1.75	1487	1.94
2375	1205	1.34	1299	1.55	1384	1.76	1460	1.96	1532	2.17
2500	1258	1.54	1349	1.76	1431	1.98	1506	2.20	1576	2.41

CFM	AVAILABLE EXTERNAL STATIC PRESSURE (in. wg)									
	1.2		1.4		1.6		1.8		2.0	
	RPM	BHP	RPM	BHP	RPM	BHP	RPM	BHP	RPM	BHP
	High Static Option with Field Supplied Drive ¹						High Static Option			
1500	1312	1.07	1380	1.20	1445	1.34	1506	1.48	1564	1.62
1625	1350	1.21	1418	1.35	1482	1.50	1542	1.64	1600	1.79
1750	1390	1.36	1457	1.51	1520	1.67	1580	1.83	1637	1.98
1875	1430	1.53	1496	1.69	1559	1.86	1618	2.02	1675	2.19
2000	1471	1.72	1536	1.89	1598	2.06	1657	2.24	1713	2.41
2125	1513	1.92	1577	2.10	1638	2.28	1696	2.47	1752	2.65
2250	1555	2.13	1619	2.33	1679	2.52	1736	2.72	-	-
2375	1598	2.37	1661	2.57	1720	2.78	-	-	-	-
2500	1642	2.63	1704	2.84	-	-	-	-	-	-

NOTE: For more information, see General Fan Performance Notes on page 47.

Boldface indicates field-supplied drive is required.

1. Recommend using field-supplied motor pulley (part number KR11HY161) blower pulley (part no. KR11AZ406), and belt (part number KR29AF038)

APPENDIX III FAN PERFORMANCE - RGS072, 3 PHASE, 6 TON HORIZONTAL SUPPLY

CFM	AVAILABLE EXTERNAL STATIC PRESSURE (in. wg)									
	0.2		0.4		0.6		0.8		1.0	
	RPM	BHP	RPM	BHP	RPM	BHP	RPM	BHP	RPM	BHP
	Field-Supplied Drive¹		Standard Static Option						High Static Option with Field Supplied Drive²	
1800	913	0.64	1010	0.80	1098	0.98	1178	1.16	1252	1.35
1950	972	0.78	1065	0.96	1148	1.14	1226	1.34	1298	1.54
2100	1032	0.95	1120	1.14	1200	1.33	1275	1.54	1345	1.75
2250	1093	1.14	1177	1.34	1254	1.55	1325	1.76	1393	1.98
2400	1155	1.36	1234	1.57	1308	1.78	1377	2.01	1443	2.24
2550	1217	1.60	1293	1.82	1363	2.05	1430	2.28	1494	2.53
2700	1280	1.87	1352	2.10	1420	2.34	1484	2.59	1546	2.84
2850	1343	2.17	1412	2.42	1477	2.67	1539	2.93	1599	3.19
3000	1406	2.50	1472	2.76	1535	3.03	1595	3.29	1653	3.57

CFM	AVAILABLE EXTERNAL STATIC PRESSURE (in. wg)									
	1.2		1.4		1.6		1.8		2.0	
	RPM	BHP	RPM	BHP	RPM	BHP	RPM	BHP	RPM	BHP
	High Static Option with Field Supplied Drive²								High Static Option	
1800	1322	1.56	1388	1.77	1451	1.98	1510	2.21	1568	2.44
1950	1366	1.75	1430	1.97	1491	2.20	1550	2.43	1606	2.67
2100	1411	1.97	1473	2.20	1533	2.43	1590	2.67	1645	2.92
2250	1457	2.21	1518	2.45	1576	2.69	1632	2.94	1686	3.20
2400	1505	2.48	1564	2.73	1621	2.98	1676	3.24	1729	3.51
2550	1554	2.78	1612	3.03	1667	3.30	1721	3.57	-	-
2700	1604	3.10	1660	3.37	1715	3.64	-	-	-	-
2850	1656	3.46	-	-	-	-	-	-	-	-
3000	-	-	-	-	-	-	-	-	-	-

NOTE: For more information, see General Fan Performance Notes on page 47.

Boldface indicates field-supplied drive is required.

1. Recommend using field-supplied blower pulley (part no. KR11AZ406), motor pulley (part no. KR11HY151) and belt (part no. KR29AF035).
2. Recommend using field-supplied motor pulley (part number KR11HY184) blower pulley (part no. KR11AD561), and belt (part number KR29AF041).

APPENDIX III FAN PERFORMANCE - RGS072, 3 PHASE, 6 TON VERTICAL SUPPLY

CFM	AVAILABLE EXTERNAL STATIC PRESSURE (in. wg)									
	0.2		0.4		0.6		0.8		1.0	
	RPM	BHP	RPM	BHP	RPM	BHP	RPM	BHP	RPM	BHP
	Standard Static Option						High Static Option with Field Supplied Drive²			
1800	967	0.63	1075	0.80	1170	0.97	1255	1.13	1333	1.28
1950	1029	0.77	1132	0.96	1223	1.14	1306	1.32	1382	1.49
2100	1091	0.93	1189	1.14	1278	1.33	1358	1.52	1433	1.71
2250	1154	1.11	1248	1.33	1333	1.55	1411	1.75	1484	1.96
2400	1218	1.32	1308	1.55	1390	1.78	1466	2.01	1537	2.23
2550	1283	1.55	1369	1.80	1448	2.05	1521	2.29	1590	2.52
2700	1348	1.80	1431	2.07	1507	2.33	1578	2.59	1645	2.84
2850	1414	2.09	1493	2.37	1566	2.65	1636	2.92	1701	3.19
3000	1479	2.40	1556	2.70	1627	3.00	1694	3.29	1757	3.57

CFM	AVAILABLE EXTERNAL STATIC PRESSURE (in. wg)									
	1.2		1.4		1.6		1.8		2.0	
	RPM	BHP	RPM	BHP	RPM	BHP	RPM	BHP	RPM	BHP
	High Static Option with Field Supplied Drive²						High Static Option			
1800	1406	1.43	1475	1.58	1540	1.72	1601	1.87	1660	2.00
1950	1454	1.65	1521	1.82	1585	1.98	1645	2.13	1703	2.29
2100	1502	1.89	1568	2.07	1631	2.25	1690	2.42	1747	2.59
2250	1552	2.15	1617	2.35	1678	2.54	1737	2.73	1793	2.92
2400	1603	2.44	1666	2.65	1727	2.86	1784	3.06	1839	3.26
2550	1655	2.75	1717	2.98	1776	3.20	1833	3.42	1887	3.64
2700	1709	3.09	1769	3.33	1827	3.57	-	-	-	-
2850	1763	3.45	-	-	-	-	-	-	-	-
3000	-	-	-	-	-	-	-	-	-	-

NOTE: For more information, see General Fan Performance Notes on page 47.

Boldface indicates field-supplied drive is required.

1. Recommend using field-supplied blower pulley (part no. KR11AZ406), motor pulley (part no. KR11HY151) and belt (part no. KR29AF035).
2. Recommend using field-supplied motor pulley (part number KR11HY184) blower pulley (part no. KR11AD561), and belt (part number KR29AF041).

APPENDIX III FAN PERFORMANCE - RGS091, 3 PHASE, 7.5 TON HORIZONTAL SUPPLY

CFM	AVAILABLE EXTERNAL STATIC PRESSURE (in. wg)									
	0.2		0.4		0.6		0.8		1.0	
	RPM	BHP	RPM	BHP	RPM	BHP	RPM	BHP	RPM	BHP
	Standard Static Option								High Static Option with Field Supplied Drive ²	
2250	505	0.52	586	0.73	657	0.97	722	1.22	782	1.50
2438	533	0.62	610	0.85	679	1.09	742	1.36	800	1.65
2625	562	0.74	635	0.98	701	1.23	762	1.51	819	1.81
2813	591	0.88	661	1.13	725	1.39	783	1.68	839	1.98
3000	621	1.03	688	1.29	749	1.57	806	1.87	859	2.18
3188	652	1.21	715	1.48	774	1.77	829	2.07	881	2.40
3375	682	1.40	743	1.68	800	1.98	853	2.30	903	2.63
3563	713	1.61	772	1.91	826	2.22	878	2.55	927	2.89
3750	745	1.85	801	2.15	853	2.48	903	2.82	951	3.18

CFM	AVAILABLE EXTERNAL STATIC PRESSURE (in. wg)									
	1.2		1.4		1.6		1.8		2.0	
	RPM	BHP	RPM	BHP	RPM	BHP	RPM	BHP	RPM	BHP
	High Static Option with Field Supplied Drive ²					High Static Option				
2250	838	1.81	891	2.12	941	2.46	988	2.82	1033	3.19
2438	854	1.96	906	2.28	955	2.63	1001	2.99	1046	3.37
2625	872	2.12	922	2.46	970	2.81	1016	3.17	1060	3.56
2813	890	2.31	940	2.65	986	3.01	1031	3.38	1074	3.77
3000	910	2.51	958	2.86	1004	3.23	1048	3.61	1090	4.01
3188	930	2.74	977	3.10	1022	3.47	1065	3.86	1107	4.26
3375	951	2.99	997	3.35	1041	3.74	1083	4.13	1124	4.54
3563	973	3.26	1018	3.63	1061	4.02	1103	4.43	1143	4.85
3750	996	3.55	1040	3.93	1082	4.34	1122	4.75	1162	5.18

NOTE: For more information, see General Fan Performance Notes on page 47.

Boldface indicates field-supplied drive is required.

1. Recommend using field-supplied blower pulley (part no. KR11AZ002), and belt (part no. KR29AF054).
2. Recommend using field-supplied motor pulley (part number KR11HY184) blower pulley (part no. KR11AZ002), and belt (part number KR29AF052)

APPENDIX III FAN PERFORMANCE - RGS091, 3 PHASE, 7.5 TON VERTICAL SUPPLY

CFM	AVAILABLE EXTERNAL STATIC PRESSURE (in. wg)									
	0.2		0.4		0.6		0.8		1.0	
	RPM	BHP	RPM	BHP	RPM	BHP	RPM	BHP	RPM	BHP
	Standard Static Option								High Static Option with Field Supplied Drive ²	
2250	513	0.54	595	0.76	665	1.01	728	1.27	786	1.56
2438	541	0.65	620	0.89	688	1.14	750	1.42	806	1.71
2625	570	0.77	645	1.02	712	1.29	772	1.58	827	1.88
2813	600	0.91	672	1.18	736	1.46	794	1.76	848	2.07
3000	629	1.07	699	1.35	761	1.64	818	1.95	871	2.28
3188	660	1.25	726	1.54	787	1.85	842	2.17	894	2.51
3375	690	1.45	754	1.75	813	2.07	867	2.41	917	2.76
3563	721	1.67	783	1.98	840	2.32	892	2.67	941	3.03
3750	752	1.91	812	2.24	867	2.59	918	2.95	966	3.32

CFM	AVAILABLE EXTERNAL STATIC PRESSURE (in. wg)									
	1.2		1.4		1.6		1.8		2.0	
	RPM	BHP	RPM	BHP	RPM	BHP	RPM	BHP	RPM	BHP
	High Static Option with Field Supplied Drive ²					High Static Option				
2250	839	1.86	889	2.18	935	2.52	980	2.87	1022	3.23
2438	858	2.02	907	2.35	953	2.70	997	3.06	1039	3.43
2625	878	2.20	926	2.54	972	2.89	1015	3.26	1056	3.64
2813	899	2.40	946	2.75	991	3.11	1033	3.49	1074	3.88
3000	920	2.62	966	2.98	1010	3.35	1052	3.74	1093	4.14
3188	942	2.86	987	3.23	1031	3.61	1072	4.01	1112	4.42
3375	964	3.12	1009	3.50	1052	3.89	1093	4.30	1132	4.72
3563	988	3.41	1032	3.80	1074	4.20	1114	4.61	1152	5.04
3750	1011	3.71	1054	4.11	1096	4.53	1135	4.95	-	-

NOTE: For more information, see General Fan Performance Notes on page 47.

Boldface indicates field-supplied drive is required.

1. Recommend using field-supplied blower pulley (part no. KR11AZ002), and belt (part no. KR29AF054).
2. Recommend using field-supplied motor pulley (part number KR11HY184) blower pulley (part no. KR11AZ002), and belt (part number KR29AF052)

APPENDIX III FAN PERFORMANCE - RGS101, 3 PHASE, 8.5 TON HORIZONTAL SUPPLY

CFM	AVAILABLE EXTERNAL STATIC PRESSURE (in. wg)									
	0.2		0.4		0.6		0.8		1.0	
	RPM	BHP	RPM	BHP	RPM	BHP	RPM	BHP	RPM	BHP
	Field-Supplied Drive¹		Standard Static Option						High Static Option with Field Supplied Drive²	
2550	497	0.48	579	0.61	651	0.75	717	0.90	777	1.05
2763	524	0.58	602	0.72	671	0.87	735	1.03	794	1.19
2975	551	0.70	626	0.86	693	1.01	754	1.18	812	1.35
3188	580	0.84	651	1.00	716	1.17	775	1.34	831	1.52
3400	609	1.00	677	1.17	739	1.35	797	1.53	851	1.71
3613	638	1.17	703	1.35	763	1.54	819	1.73	871	1.93
3825	668	1.37	730	1.56	788	1.76	842	1.96	893	2.16
4038	698	1.59	758	1.79	813	2.00	866	2.20	915	2.42
4250	728	1.83	786	2.04	839	2.26	890	2.47	938	2.70

CFM	AVAILABLE EXTERNAL STATIC PRESSURE (in. wg)									
	1.2		1.4		1.6		1.8		2.0	
	RPM	BHP	RPM	BHP	RPM	BHP	RPM	BHP	RPM	BHP
	High Static Option with Field Supplied Drive²					High Static Option				
2550	833	1.21	886	1.38	936	1.56	984	1.74	1029	1.93
2763	849	1.36	900	1.53	950	1.72	996	1.90	1041	2.10
2975	865	1.52	916	1.70	964	1.89	1010	2.09	1054	2.29
3188	883	1.70	933	1.89	980	2.09	1025	2.29	1068	2.50
3400	902	1.90	950	2.10	996	2.30	1041	2.51	1083	2.73
3613	921	2.13	969	2.33	1014	2.54	1057	2.76	1099	2.98
3825	941	2.37	988	2.58	1032	2.80	1075	3.02	1116	3.25
4038	963	2.63	1008	2.86	1051	3.08	1093	3.31	1133	3.55
4250	984	2.92	1029	3.15	1071	3.39	1112	3.63	1152	3.87

NOTE: For more information, see General Fan Performance Notes on page 47.

Boldface indicates field-supplied drive is required.

1. Recommend using field-supplied blower pulley (part no. KR11AK012), and belt (part no. KR29AF055).

2. Recommend using field-supplied motor pulley (part number KR11HY171) and belt (part number KR30AE048)

APPENDIX III FAN PERFORMANCE - RGS101, 3 PHASE, 8.5 TON VERTICAL SUPPLY

CFM	AVAILABLE EXTERNAL STATIC PRESSURE (in. wg)									
	0.2		0.4		0.6		0.8		1.0	
	RPM	BHP	RPM	BHP	RPM	BHP	RPM	BHP	RPM	BHP
	Standard Static Option								High Static Option with Field Supplied Drive¹	
2550	526	0.51	600	0.65	666	0.79	727	0.93	783	1.07
2763	557	0.62	627	0.77	690	0.92	749	1.08	804	1.23
2975	588	0.75	655	0.91	716	1.08	772	1.24	825	1.40
3188	621	0.90	684	1.07	743	1.25	797	1.42	848	1.60
3400	653	1.06	714	1.25	770	1.44	822	1.62	872	1.81
3613	687	1.25	744	1.45	798	1.65	849	1.84	897	2.04
3825	720	1.45	775	1.67	827	1.88	876	2.09	922	2.30
4038	754	1.69	807	1.91	856	2.13	904	2.35	949	2.57
4250	788	1.94	839	2.17	886	2.41	932	2.64	976	2.88

CFM	AVAILABLE EXTERNAL STATIC PRESSURE (in. wg)									
	1.2		1.4		1.6		1.8		2.0	
	RPM	BHP	RPM	BHP	RPM	BHP	RPM	BHP	RPM	BHP
	High Static Option with Field Supplied Drive¹					High Static Option				
2550	836	1.20	886	1.34	934	1.48	979	1.61	1022	1.74
2763	855	1.37	904	1.52	950	1.67	995	1.82	1037	1.97
2975	875	1.56	923	1.72	968	1.88	1012	2.04	1053	2.20
3188	897	1.77	943	1.94	987	2.11	1030	2.29	1071	2.46
3400	919	1.99	964	2.18	1007	2.36	1049	2.55	1089	2.73
3613	943	2.24	986	2.44	1029	2.63	1069	2.83	1108	3.02
3825	967	2.51	1010	2.71	1051	2.92	1090	3.13	1129	3.34
4038	992	2.80	1034	3.02	1074	3.24	1112	3.46	1150	3.68
4250	1018	3.11	1058	3.34	1097	3.57	-	-	-	-

NOTE: For more information, see General Fan Performance Notes on page 47.

Boldface indicates field-supplied drive is required.

1. Recommend using field-supplied motor pulley (part number KR11HY171) and belt (part number KR30AE048)

APPENDIX III FAN PERFORMANCE - RGS121, 3 PHASE, 10 TON HORIZONTAL SUPPLY

CFM	AVAILABLE EXTERNAL STATIC PRESSURE (in. wg)									
	0.2		0.4		0.6		0.8		1.0	
	RPM	BHP	RPM	BHP	RPM	BHP	RPM	BHP	RPM	BHP
	Field-Supplied Drive¹		Standard Static Option						High Static Option with Field Supplied Drive²	
3000	579	0.70	660	0.89	732	1.09	799	1.29	860	1.50
3250	613	0.85	690	1.06	760	1.27	823	1.49	883	1.71
3500	648	1.03	721	1.25	788	1.48	850	1.71	907	1.95
3750	683	1.23	753	1.47	817	1.71	877	1.96	933	2.21
4000	719	1.45	786	1.71	848	1.97	905	2.23	959	2.50
4250	756	1.71	819	1.98	879	2.26	934	2.53	987	2.81
4500	792	1.99	853	2.28	910	2.57	964	2.87	1015	3.16
4750	830	2.31	888	2.62	943	2.92	995	3.23	1044	3.54
5000	867	2.66	923	2.98	976	3.30	1026	3.63	1074	3.95

CFM	AVAILABLE EXTERNAL STATIC PRESSURE (in. wg)									
	1.2		1.4		1.6		1.8		2.0	
	RPM	BHP	RPM	BHP	RPM	BHP	RPM	BHP	RPM	BHP
	High Static Option with Field Supplied Drive²						High Static Option			
3000	917	1.70	970	1.91	1021	2.13	1070	2.34	1117	2.56
3250	938	1.93	991	2.16	1041	2.38	1089	2.61	1134	2.85
3500	961	2.18	1013	2.42	1062	2.66	1108	2.91	1153	3.15
3750	985	2.46	1035	2.71	1083	2.97	1129	3.23	1173	3.49
4000	1011	2.76	1059	3.03	1106	3.30	1151	3.58	1194	3.85
4250	1037	3.09	1084	3.38	1130	3.66	1174	3.95	1216	4.24
4500	1064	3.46	1110	3.76	1155	4.06	1198	4.36	1239	4.66
4750	1091	3.85	1137	4.16	1180	4.48	1222	4.80	1263	5.12
5000	1120	4.28	1164	4.61	1207	4.94	-	-	-	-

NOTE: For more information, see General Fan Performance Notes on page 47.

Boldface indicates field-supplied drive is required.

1. Recommend using field-supplied blower pulley (part no. KR11AD912), and belt (part no. KR29AF051).
2. Recommend using field-supplied motor pulley (part number KR11HY184) blower pulley (part no. KR11AZ712), and belt (part number KR29AF049).

APPENDIX III FAN PERFORMANCE - 3 PHASE, 10 TON VERTICAL SUPPLY

CFM	AVAILABLE EXTERNAL STATIC PRESSURE (in. wg)									
	0.2		0.4		0.6		0.8		1.0	
	RPM	BHP	RPM	BHP	RPM	BHP	RPM	BHP	RPM	BHP
	Standard Static Option						High Static Option with Field Supplied Drive¹			
3000	616	0.79	689	0.97	757	1.16	821	1.36	882	1.57
3250	655	0.96	724	1.16	788	1.37	849	1.58	907	1.80
3500	695	1.17	760	1.38	821	1.60	879	1.83	934	2.06
3750	736	1.41	797	1.63	855	1.86	910	2.10	963	2.35
4000	777	1.68	834	1.91	889	2.16	942	2.41	993	2.67
4250	818	1.98	873	2.23	925	2.49	976	2.75	1025	3.02
4500	860	2.32	912	2.58	962	2.85	1010	3.13	1057	3.41
4750	902	2.69	951	2.97	999	3.26	1046	3.55	1091	3.84
5000	944	3.11	991	3.40	1037	3.70	1082	4.00	1125	4.31

CFM	AVAILABLE EXTERNAL STATIC PRESSURE (in. wg)									
	1.2		1.4		1.6		1.8		2.0	
	RPM	BHP	RPM	BHP	RPM	BHP	RPM	BHP	RPM	BHP
	High Static Option with Field Supplied Drive¹						High Static Option			
3000	939	1.79	994	2.01	1047	2.24	1098	2.47	1147	2.71
3250	962	2.03	1015	2.26	1066	2.50	1115	2.75	1163	3.00
3500	987	2.30	1038	2.54	1088	2.80	1135	3.05	1181	3.32
3750	1014	2.60	1063	2.86	1111	3.12	1157	3.39	1202	3.66
4000	1042	2.93	1090	3.20	1136	3.48	1180	3.76	1224	4.04
4250	1072	3.30	1118	3.58	1162	3.87	1205	4.16	1247	4.46
4500	1103	3.70	1147	4.00	1190	4.29	1232	4.60	1273	4.91
4750	1135	4.14	1177	4.45	1219	4.76	1259	5.08	-	-
5000	1167	4.63	1209	4.95	-	-	-	-	-	-

NOTE: For more information, see General Fan Performance Notes on page 47.

Boldface indicates field-supplied drive is required.

1. Recommend using field-supplied motor pulley (part number KR11HY184) blower pulley (part no. KR11AZ712), and belt (part number KR29AF049).

APPENDIX III FAN PERFORMANCE - PULLEY ADJUSTMENT

UNIT		MOTOR/DRIVE COMBO	MOTOR PULLEY TURNS OPEN										
			0.0	0.5	1.0	1.5	2.0	2.5	3.0	3.5	4.0	4.5	5.0
RGS036	1 phase	Standard Static	854	825	795	766	736	707	678	648	619	589	560
		High Static	1175	1135	1094	1054	1013	973	932	892	851	811	770
	3 phase	Standard Static	854	825	795	766	736	707	678	648	619	589	560
		High Static	1466	1423	1380	1337	1294	1251	1207	1164	1121	1078	1035
RGS048	1 phase	Standard Static	854	825	795	766	736	707	678	648	619	589	560
		High Static	1175	1135	1094	1054	1013	973	932	892	851	811	770
	3 phase	Standard Static	854	825	795	766	736	707	678	648	619	589	560
		High Static	1466	1423	1380	1337	1294	1251	1207	1164	1121	1078	1035
RGS060	1 phase	Standard Static	1175	1135	1094	1054	1013	973	932	892	851	811	770
		High Static	1466	1423	1380	1337	1294	1251	1207	1164	1121	1078	1035
	3 phase	Standard Static	1175	1135	1094	1054	1013	973	932	892	851	811	770
		High Static	1687	1649	1610	1572	1533	1495	1457	1418	1380	1341	1303
RGS072	3 phase	Standard Static	1457	1419	1380	1342	1303	1265	1227	1188	1150	1111	1073
		High Static	1788	1757	1725	1694	1662	1631	1600	1568	1537	1505	1474
RGS091	3 phase	Standard Static	747	721	695	670	644	618	592	566	541	515	489
		High Static	1102	1083	1063	1044	1025	1006	986	967	948	928	909
RGS101	3 phase	Standard Static	733	712	690	669	647	626	604	583	561	540	518
		High Static	1084	1059	1035	1010	986	961	936	912	887	863	838
RGS121	3 phase	Standard Static	838	813	789	764	739	715	690	665	640	616	591
		High Static	1240	1218	1196	1175	1153	1131	1109	1087	1066	1044	1022

NOTE: Do not adjust pulley further than 5 turns open.

■ – Factory settings

APPENDIX III FAN PERFORMANCE - 3-10 Ton R-410A Rooftop Indoor Fan System Standard, Optional High Static and Field Installed Medium Static Drive Options

UNIT MODEL NUMBER		RGS036	RGS048	RGS060	RGS072	RGS091	RGS101	RGS121
UNIT TONNAGE		3	4	5	6	7.5	8.5	10
INDOOR FAN (Standard static)								
ID Fan Motor (Standard Static)	Voltage-Ph							
Indoor Motor Part No.	208/230-1	HC52ER230	HC52ER230	HC52ER230	N/A	N/A	N/A	N/A
Indoor Motor Max Continuous BHP	208/230-1	1.2	1.2	1.2	N/A	N/A	N/A	N/A
Indoor Motor Part No.	208/230-3	HC52ER230	HC52ER230	HC52ER230	HD56FE652	HD56FR652	HD56FR652	HD56FE652
Indoor Motor Max Continuous BHP	208/230-3	1.2	1.2	1.2	2.4	1.7	1.7	2.4
Indoor Motor Part No.	460-3	HC52ER460	HC52ER460	HC52ER460	HD56FE652	HD56FR652	HD56FR652	HD56FE652
Indoor Motor Max Continuous BHP	460-3	1.2	1.2	1.2	2.4	1.7	1.7	2.4
Indoor Motor Part No.	575-3	HC52EE575	HC52EE575	HC52EE575	HD56FE575	HD56FR575	HD56FR575	HD56FE575
Indoor Motor Max Continuous BHP	575-3	1	1	1	2.4	1.7	1.7	2.4
ID Fan Wheel, Shaft, Bearings, Drive (Belt Drive Standard Static)								
Motor Pulley Part No.	Same all voltages except 575v as noted	KR11HY151	KR11HY151	KR11HY151	KR11HY171	KR11HY151	KR11HY161	KR11HY161
Motor Pulley Pitch Diameter A min (in.)		1.9	1.9	1.9	2.8	1.9	2.4	2.4
Motor Pulley Pitch Diameter A max (in.)		2.9	2.9	2.9	3.8	2.9	3.4	3.4
Blower Pulley Part No.		KR11AZ606	KR11AZ606	KR11AZ406	KR11AD516	KR11AD612	KR11AZ002	KR11AZ712
Blower Pulley Pitch Diameter A (in.)		5.5	5.5	4	4.5	6.7	8	7
Belt Part No.		KR30AE037	KR30AE037	KR29AF035	KR29AF041	KR29AF048	KR29AF049	KR29AF048
Belt...Type		A	A	AX	AX	AX	AX	AX
Belt Pitch Length		38.3	38.3	36.3	42.3	49.3	50.3	49.3
Motor Pulley Part No.	575-3	KR11HY150	KR11HY150	KR11HY150	Same all voltages			
Motor Pulley Pitch Diameter A min (in.)	575-3	1.9	1.9	1.9				
Motor Pulley Pitch Diameter A max (in.)	575-3	2.9	2.9	2.9				
ID Fan Motor (Medium Static) **								
Indoor Motor Part No.	208/230-1	HC52ER230	HC52ER230	HC54FB230	N/A	N/A	N/A	N/A
Indoor Motor Max Continuous BHP	208/230-1	1.2	1.2	1.5	N/A	N/A	N/A	N/A
Indoor Motor Part No.	208/230-3	HC52ER230	HC52ER230	HD56FE652	HD58FE651	HD58FE651	HD56FE652	HD60FE655
Indoor Motor Max Continuous BHP	208/230-3	1.2	1.2	2.4	2.9	2.9	2.4	3.7
Indoor Motor Part No.	460-3	HC52ER460	HC52ER460	HD56FE652	HD58FE651	HD58FE651	HD56FE652	HD60FE655
Indoor Motor Max Continuous BHP	460-3	1.2	1.2	2.4	2.9	2.9	2.4	3.7
Indoor Motor Part No.	575-3	HC52EE575	HC52EE575	HD56FE575	HD58FE576	HD58FE576	HD56FE575	HD58FE576
Indoor Motor Capacitor	575-3	HC91CL015	HC91CL015	N/A	N/A	N/A	N/A	N/A
Indoor Motor Max Continuous BHP	575-3	1	1	2.4	3.7	3.7	2.4	3.7
ID Fan Wheel, Shaft, Bearings, Drive (Medium Static)								
Motor Pulley Part No.	Same all voltages except 575v as noted	KR11HY151	KR11HY151	KR11HY161	KR11HY184	KR11HY184	KR11HY171	KR11HY184
Motor Pulley Pitch Diameter A min (in.)		1.9	1.9	2.4	3.4	3.4	2.8	3.4
Motor Pulley Pitch Diameter A max (in.)		2.9	2.9	3.4	4.4	4.4	3.8	4.4
Blower Pulley Part No.		KR11AZ406	KR11AZ406	KR11AZ406	KR11AD561	KR11AZ002	KR11AZ712	KR11AZ712
Blower Pulley Pitch Diameter A (in.)		4	4	4	5	8	7	7
Belt Part No.		KR29AF035	KR29AF035	KR29AF038	KR29AF041	KR29AF052	KR30AE048	KR29AF049
Belt...Type		AX	AX	AX	AX	AX	A	AX
Belt Pitch Length		36.3	36.3	39.3	42.3	53.3	49.3	50.3
Motor Pulley Part No.	575-3	KR11HY150	KR11HY150	Same all voltages				
Motor Pulley Pitch Diameter A min (in.)	575-3	1.9	1.9					
Motor Pulley Pitch Diameter A max (in.)	575-3	2.9	2.9					

FAN PERFORMANCE (Cont.) - 3-10 Ton R-410A Rooftop Indoor Fan System Standard, Optional High Static and Field Installed Medium Static Drive Options

UNIT MODEL NUMBER		RGS036	RGS048	RGS060	RGS072	RGS091	RGS101	RGS121
UNIT TONNAGE		3	4	5	6	7.5	8.5	10
ID Fan Motor (High Static)								
Indoor Motor Part No.	208/230-1	N/A	N/A	N/A	N/A	N/A	N/A	N/A
Indoor Motor Part No.	208/230-3	HD56FE652	HD56FE65	HD58FE65	HD60FE65	HD60FK65	HD60FE65	HD60FK65
Indoor Motor Max Continuous BHP	208/230-3	2.4	2.4	2.9	3.7	4.7	3.7	4.7
Indoor Motor Part No.	460-3	HD56FE652	HD56FE65	HD58FE65	HD60FE65	HD60FK65	HD60FE65	HD60FK65
Indoor Motor Max Continuous BHP	460-3	2.4	2.4	2.9	3.7	4.7	3.7	4.7
Indoor Motor Part No.	575-3	HD56FE575	HD56FE57	HD58FE57	HD58FE57	HD60FE57	HD58FE57	HD60FE57
Indoor Motor Max Continuous BHP	575-3	2.4	2.4	3.7	3.7	4.7	3.7	4.7
ID Fan Wheel, Shaft, Bearings, Drive (High Static)								
Indoor Fan Wheel Part No.	208/230-1	N/A	N/A	N/A	N/A	N/A	N/A	N/A
Motor Pulley Part No.	Same all voltages	KR11HY161	KR11HY161	KR11HY184	KR11HY310	KR11HY310	KR11HY184	KR11HY310
Motor Pulley Type		Variable	Variable	Variable	Variable	Variable	Variable	Variable
Motor Pulley Pitch Diameter A min (in.)		2.4	2.4	3.4	4.7	4.7	3.4	4.7
Motor Pulley Pitch Diameter A max (in.)		3.4	3.4	4.4	5.7	5.7	4.4	5.7
Blower Pulley Part No.		KR11AZ406	KR11AZ406	KR11AD516	KR11AZ606	KR11AD912	KR11AZ712	KR11AZ002
Blower Pulley Type		Fixed	Fixed	Fixed	Fixed	Fixed	Fixed	Fixed
Blower Pulley Pitch Diameter A (in.)		4	4	4.5	5.5	9	7	8
Belt Part No.		KR29AF038	KR29AF038	KR29AF041	KR30AE04	KR29AF056	KR29AF049	KR29AF054
					3			

** Medium static motor and drives available from FAST parts

APPENDIX IV ELECTRICAL DATA RGS036, 3 TONS

V-Ph-Hz	VOLTAGE RANGE		COMP (ea)		OFM (ea)		IFM				
	MIN	MAX	RLA	LRA	WATTS	FLA	TYPE	Max WATTS	Max AMP Draw	EFF at Full Load	FLA
208-1-60	187	253	16.6	79	325	1.5	Std Static	1000	5.1	70%	4.9
							High Static	1000	5.1	70%	4.9
230-1-60	187	253	16.6	79	325	1.5	Std Static	1000	5.1	70%	4.9
							High Static	1000	5.1	70%	4.9
208-3-60	187	253	10.4	73	325	1.5	Std Static	1000	5.1	70%	4.9
							High Static	2120	5.5	80%	5.2
230-3-60	187	253	10.4	73	325	1.5	Std Static	1000	5.1	70%	4.9
							High Static	2120	5.5	80%	5.2
460-3-60	414	506	5.8	38	325	0.8	Std Static	1000	2.2	70%	2.1
							High Static	2120	2.7	80%	2.6
575-3-60	518	633	3.8	37	325	0.6	Std Static	1000	2.0	71%	1.9
							High Static	2120	2.1	80%	2.0

APPENDIX IV ELECTRICAL DATA RGS048, 4 TONS

V-Ph-Hz	VOLTAGE RANGE		COMP (ea)		OFM (ea)		IFM				
	MIN	MAX	RLA	LRA	WATTS	FLA	TYPE	Max WATTS	Max AMP Draw	EFF at Full Load	FLA
208-1-60	187	253	21.8	117	325	1.5	Std Static	1000	5.1	70%	4.9
							High Static	1850	7.4	78%	7.0
230-1-60	187	253	21.8	117	325	1.5	Std Static	1000	5.1	70%	4.9
							High Static	1850	7.4	78%	7.0
208-3-60	187	253	13.7	83	325	1.5	Std Static	1000	5.1	70%	4.9
							High Static	2120	5.5	80%	5.2
230-3-60	187	253	13.7	83	325	1.5	Std Static	1000	5.1	70%	4.9
							High Static	2120	5.5	80%	5.2
460-3-60	414	506	6.2	41	325	0.8	Std Static	1000	2.2	70%	2.1
							High Static	2120	2.7	80%	2.6
575-3-60	518	633	4.8	37	325	0.6	Std Static	1000	2.0	71%	1.9
							High Static	2120	2.1	80%	2.0

APPENDIX IV ELECTRICAL DATA RGS060, 5 TONS

V-Ph-Hz	VOLTAGE RANGE		COMP (ea)		OFM (ea)		IFM				
	MIN	MAX	RLA	LRA	WATTS	FLA	TYPE	Max	Max	EFF at Full Load	FLA
								WATTS	AMP Draw		
208-1-60	187	253	26.2	134	325	1.5	Std Static High Static	1000	5.1	70%	4.9
								1850	7.4	78%	7.0
230-1-60	187	253	26.2	134	325	1.5	Std Static High Static	1000	5.1	70%	4.9
								1850	7.4	78%	7.0
208-3-60	187	253	15.6	110	325	1.5	Std Static High Static	1000	5.1	70%	4.9
								2615	7.9	81%	7.5
230-3-60	187	253	15.6	110	325	1.5	Std Static High Static	1000	5.1	70%	4.9
								2615	7.9	81%	7.5
460-3-60	414	506	7.7	52	325	0.8	Std Static High Static	1000	2.2	70%	2.1
								2615	3.6	81%	3.4
575-3-60	518	633	5.8	39	325	0.6	Std Static High Static	1000	2.0	71%	1.9
								3775	2.9	81%	2.8

APPENDIX IV ELECTRICAL DATA RGS072, 6 TONS

V-Ph-Hz	VOLTAGE RANGE		COMP (ea)		OFM (ea)		IFM				
	MIN	MAX	RLA	LRA	WATTS	FLA	TYPE	Max	Max	EFF at Full Load	FLA
								WATTS	AMP Draw		
208-3-60	187	253	19.0	123	325	1.5	Std Static High Static	2120	5.5	80%	5.2
								2615	7.9	81%	7.5
230-3-60	187	253	19.0	123	325	1.5	Std Static High Static	2120	5.5	80%	5.2
								2615	7.9	81%	7.5
460-3-60	414	506	9.7	62	325	0.8	Std Static High Static	2120	2.7	80%	2.6
								3775	4.6	81%	4.4
575-3-60	518	633	7.4	50	325	0.6	Std Static High Static	2120	2.1	80%	2.0
								3775	2.9	81%	2.8

APPENDIX IV ELECTRICAL DATA RGS091, 7.5 TONS

V-Ph-Hz	VOLTAGE RANGE		COMP (ea)		OFM (ea)		IFM				
	MIN	MAX	RLA	LRA	WATTS	FLA	TYPE	Max	Max	EFF at Full Load	FLA
								WATTS	AMP Draw		
208-3-60	187	253	25.0	164	325	1.5	Std Static High Static	1448	5.5	80%	5.2
								4559	15.8	81%	15.0
230-3-60	187	253	25.0	164	325	1.5	Std Static High Static	1448	5.5	80%	5.2
								4559	15.8	81%	15.0
460-3-60	414	506	12.2	100	325	0.8	Std Static High Static	1448	2.7	80%	2.6
								4559	7.8	81%	7.4
575-3-60	518	633	9.0	78	325	0.6	Std Static High Static	1379	2.5	80%	2.4
								1870	5.9	81%	5.6

APPENDIX IV ELECTRICAL DATA RGS101, 8.5 TONS

V-Ph-Hz	VOLTAGE RANGE		COMP (ea)		OFM (ea)		IFM				
	MIN	MAX	RLA	LRA	WATTS	FLA	TYPE	Max WATTS	Max AMP Draw	EFF at Full Load	FLA
208-3-60	187	253	29.5	195	325	1.5	Std Static High Static	1448 2694	5.5 10.5	80% 80%	5.2 10.0
230-3-60	187	253	29.5	195	325	1.5	Std Static High Static	1448 2694	5.5 10.5	80% 80%	5.2 10.0
460-3-60	414	506	14.7	95	325	0.8	Std Static High Static	1448 2694	2.7 4.6	80% 80%	2.6 4.4
575-3-60	518	633	12.2	80	325	0.6	Std Static High Static	1379 3775	2.5 2.9	80% 81%	2.4 2.8

APPENDIX IV ELECTRICAL DATA RGS121, 10 TONS

V-Ph-Hz	VOLTAGE RANGE		COMP (ea)		OFM (ea)		IFM				
	MIN	MAX	RLA	LRA	WATTS	FLA	TYPE	Max WATTS	Max AMP Draw	EFF at Full Load	FLA
208-3-60	187	253	30.1	225	325	1.5	Std Static High Static	2120 4559	5.5 15.8	80% 81%	5.2 15.0
230-3-60	187	253	30.1	225	325	1.5	Std Static High Static	2120 4559	5.5 15.8	80% 81%	5.2 15.0
460-3-60	414	506	16.7	114	325	0.8	Std Static High Static	2120 4559	2.7 7.8	80% 81%	2.6 7.4
575-3-60	518	633	12.2	80	325	0.6	Std Static High Static	1390 1870	2.1 5.9	80% 81%	2.0 5.6

APPENDIX IV ELECTRICAL DATA MCA/MOCP DETERMINATION NO C.O. OR UNPWRD C.O.

Unit	NOM. V- Ph- Hz	IFM TYPE	Combustion Fan Motor FLA	Power Exhaust FLA	NO C.O. or UNPWRD C.O.							
					NO P.E.				w/ P.E. (pwrd fr/ unit)			
					MCA	MOCP	DISC. SIZE		MCA	MOCP	DISC. SIZE	
							FLA	LRA			FLA	LRA
RGS036	208/230-1-60	STD HIGH	0.48	1.9	27.2	40.0	26	95	29.1	45.0	29	97
					27.2	40.0	26	95	29.1	45.0	29	97
	208/230-3-60	STD MED* HIGH	0.48	1.9	19.4	25.0	19	89	21.3	30.0	22	91
					19.4	25.0	19	89	21.3	30.0	22	91
					19.7	30.0	20	107	21.6	30.0	22	109
	460-3-60	STD MED* HIGH	0.25	1.0	10.2	15.0	10	46	11.2	15.0	11	47
					10.2	15.0	10	46	11.2	15.0	11	47
					10.7	15.0	11	55	11.7	15.0	12	56
	575-3-60	STD MED* HIGH	0.24	1.9	7.3	15.0	7	44	9.2	15.0	9	46
					7.3	15.0	7	44	9.2	15.0	9	46
					7.4	15.0	7	50	9.3	15.0	10	52
	RGS048	208/230-1-60	STD HIGH	0.48	1.9	33.7	50.0	32	133	35.6	50.0	35
33.7						50.0	32	133	35.6	50.0	35	135
208/230-3-60		STD MED* HIGH	0.48	1.9	23.5	30.0	23	99	25.4	30.0	25	101
					23.5	30.0	23	99	25.4	30.0	25	101
					23.8	30.0	23	117	25.7	30.0	25	119
460-3-60		STD MED* HIGH	0.25	1.0	10.7	15.0	10	49	11.7	15.0	12	50
					10.7	15.0	10	49	11.7	15.0	12	50
					11.2	15.0	11	58	12.2	15.0	12	59
575-3-60		STD MED* HIGH	0.24	1.9	8.5	15.0	8	44	10.4	15.0	11	46
					8.5	15.0	8	44	10.4	15.0	11	46
					8.6	15.0	9	50	10.5	15.0	11	52
RGS060		208/230-1-60	STD HIGH	0.48	1.9	39.2	60.0	37	150	41.1	60.0	40
	41.3					60.0	40	175	43.2	60.0	42	177
	208/230-3-60	STD MED* HIGH	0.48	1.9	25.9	30.0	25	126	27.8	40.0	27	128
					26.2	40.0	26	144	28.1	40.0	28	146
					28.5	40.0	29	170	30.4	45.0	30	172
	460-3-60	STD MED* HIGH	0.25	1.0	12.5	20.0	12	60	13.5	20.0	13	61
					13.0	20.0	13	69	14.0	20.0	14	70
					13.8	20.0	14	82	14.8	20.0	15	83
	575-3-60	STD MED* HIGH	0.24	1.9	9.8	15.0	10	46	11.7	15.0	12	48
					9.9	15.0	10	52	11.8	15.0	13	54
					10.7	15.0	11	63	12.6	15.0	13	65
	RGS072	208/230-3-60	STD MED* HIGH	0.48	1.9	30.5	45.0	30	157	32.4	50.0	32
32.8						50.0	32	183	34.7	50.0	34	185
32.8						50.0	32	183	34.7	50.0	34	185
460-3-60		STD MED* HIGH	0.25	1.0	15.5	25.0	15	79	16.5	25.0	16	80
					16.3	25.0	16	92	17.3	25.0	17	93
					17.3	25.0	17	101	18.3	25.0	18	102
575-3-60		STD MED* HIGH	0.24	1.9	11.9	15.0	12	63	13.8	20.0	14	65
					12.7	20.0	12	74	14.6	20.0	15	76
					12.7	20.0	12	74	14.6	20.0	15	76

*Available from Fast Parts
See notes on next page.

APPENDIX IV ELECTRICAL DATA MCA/MOCP DETERMINATION NO C.O. OR UNPWRD C.O.

Unit	NOM. V-Ph-Hz	IFM TYPE	Combustion Fan Motor FLA	Power Exhaust FLA	NO C.O. or UNPWRD C.O.				NO C.O. or UNPWRD C.O.			
					NO P.E.				w/ P.E. (pwrd fr/ unit)			
					MCA	MOCP	DISC. SIZE		MCA	MOCP	DISC. SIZE	
							FLA	LRA			FLA	LRA
RGS091	208/230-3-60	STD	0.48	3.8	39.5	60	38	191	43.3	60	43	195
		MED*			41.8	60	41	228	45.6	60	45	232
		HIGH			49.3	60	49	254	53.1	60	54	258
	460-3-60	STD	0.25	1.8	19.5	30	19	113	21.3	30	21	115
		MED*			20.3	30	20	132	22.1	30	22	134
		HIGH			24.3	30	24	145	26.1	30	26	147
	575-3-60	STD	0.24	3.8	14.9	20	14	89	18.7	25	19	93
		MED*			15.3	20	15	104	19.1	25	19	108
		HIGH			18.1	25	18	118	21.9	30	23	122
RGS101	208/230-3-60	STD	0.48	3.8	45.1	60	43	222	48.9	60	48	226
		MED*			45.1	60	43	233	48.9	60	48	237
		HIGH			49.9	60	49	276	53.7	80	53	280
	460-3-60	STD	0.25	1.8	22.6	30	22	108	24.4	30	24	110
		MED*			22.6	30	22	114	24.4	30	24	116
		HIGH			24.4	30	24	136	26.2	30	26	138
	575-3-60	STD	0.24	3.8	18.9	30	18	91	22.7	30	23	95
		MED*			18.5	30	18	95	22.3	30	22	99
		HIGH			19.3	30	19	106	23.1	30	23	110
RGS121	208/230-3-60	STD	0.48	3.8	45.8	60	44	263	49.6	60	48	267
		MED*			50.6	60	50	306	54.4	80	54	310
		HIGH			55.6	80	55	315	59.4	80	60	319
	460-3-60	STD	0.25	1.8	25.1	30	24	133	26.9	40	26	135
		MED*			26.9	40	26	155	28.7	45	28	157
		HIGH			29.9	45	30	159	31.7	45	32	161
	575-3-60	STD	0.24	3.8	18.5	30	18	95	22.3	30	22	99
		MED*			19.3	30	19	106	23.1	30	23	110
		HIGH			22.1	30	22	120	25.9	30	26	124

* Available from Fast Parts

¹Fuse or breaker

LEGEND:

- CO - Convenient outlet
- DISC - Disconnect
- FLA - Full load amps
- IFM - Indoor fan motor
- LRA - Locked rotor amps
- MCA - Minimum circuit amps
- MOCP - Maximum over current protection
- PE - Power exhaust
- UNPWRD CO - Unpowered convenient outlet



Example: Supply voltage is 230-3-60



- AB = 224 v
- BC = 231 v
- AC = 226 v

$$\text{Average Voltage} = \frac{(224 + 231 + 226)}{3} = \frac{681}{3} = 227$$

Determine maximum deviation from average voltage.

(AB) 227 - 224 = 3 v

(BC) 231 - 227 = 4 v

(AC) 227 - 226 = 1 v

Maximum deviation is 4 v.

Determine percent of voltage imbalance.

$$\% \text{ Voltage Imbalance} = 100 \times \frac{4}{227} = 1.76\%$$

This amount of phase imbalance is satisfactory as it is below the maximum allowable 2%.

IMPORTANT: If the supply voltage phase imbalance is more than 2%, contact your local electric utility company immediately.

$$\% \text{ Voltage Imbalance} = 100 \times \frac{\text{max voltage deviation from average voltage}}{\text{average voltage}}$$

APPENDIX V. WIRING DIAGRAM LIST

Wiring Diagrams

SIZE	RGS		
	VOLTAGE	CONTROL	POWER
036	208/230-1-60	48TM500213.05	48TM500749.08
	208/230-3-60	48TM500213.05	48TM500748.08
	460-3-60	48TM500213.05	48TM500748.08
	575-3-60	48TM500213.05	48TM500215.08
048	208/230-1-60	48TM500213.05	48TM500749.08
	208/230-3-60	48TM500213.05	48TM500748.08
	460-3-60	48TM500213.05	48TM500748.08
	575-3-60	48TM500213.05	48TM500215.08
060	208/230-1-60	48TM500213.05	48TM500749.08
	208/230-3-60	48TM500213.05	48TM500748.08
	460-3-60	48TM500213.05	48TM500748.08
	575-3-60	48TM500213.05	48TM500215.08
072	208/230-3-60	48TM500213.05	48TM500748.08
	460-3-60	48TM500213.05	48TM500748.08
	575-3-60	48TM500213.05	48TM500215.08
091	208/230-3-60	48TM500929.05	48TM500803.05
	460-3-60	48TM500929.05	48TM500803.05
	575-3-60	48TM500929.05	48TM500804.05
101	208/230-3-60	48TM500929.05	48TM500803.05
	460-3-60	48TM500929.05	48TM500803.05
	575-3-60	48TM500929.05	48TM500804.05
121	208/230-3-60	48TM500929.05	48TM500803.05
	460-3-60	48TM500929.05	48TM500803.05
	575-3-60	48TM500929.05	48TM500804.05

NOTE: Component arrangement on Control; Legend on Power Schematic

APPENDIX VI. MOTORMASTER SENSOR LOCATIONS

FIGURE 47 RGS036, Outdoor Circuited

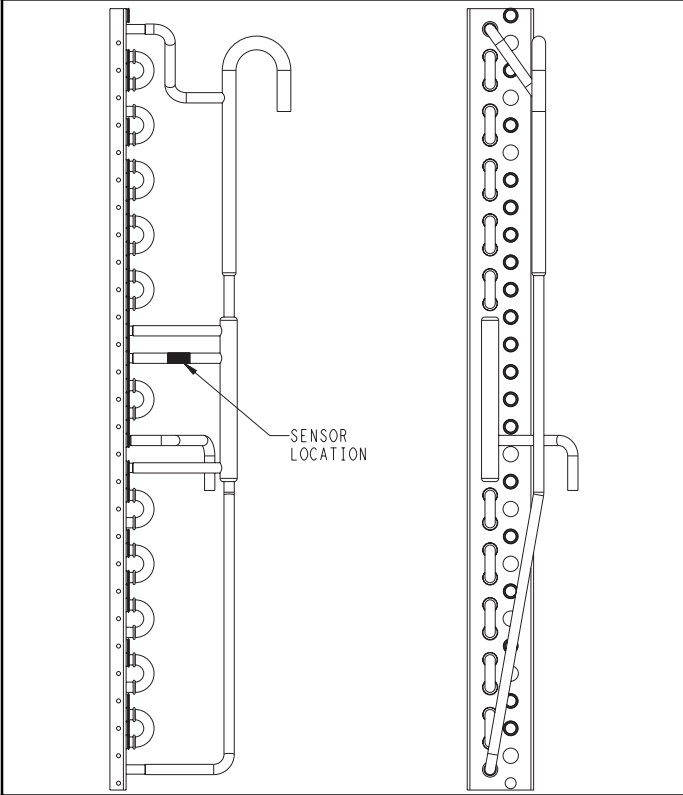

FIGURE 49 RGS072, Outdoor Circuited

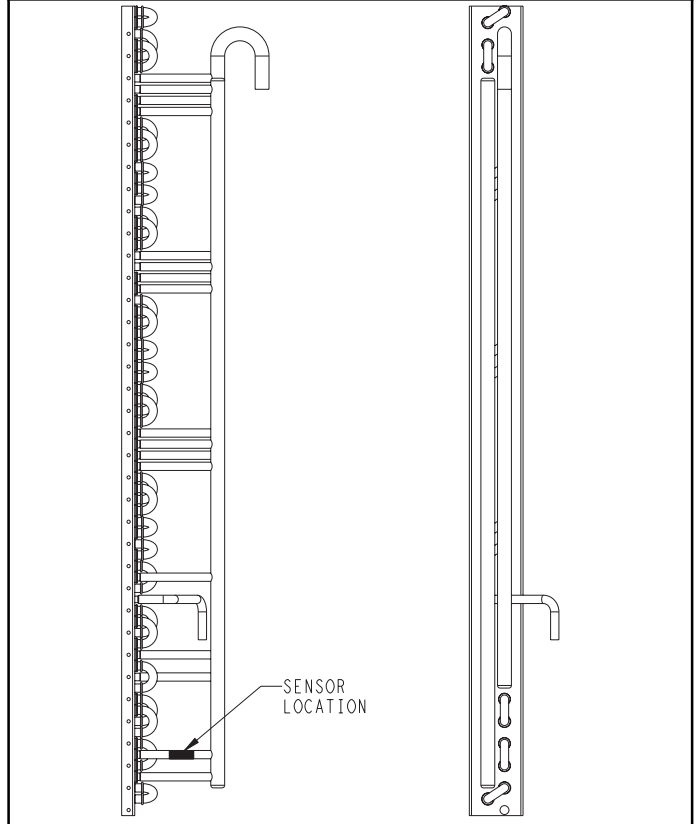

FIGURE 48 RGS048/060, Outdoor Circuited

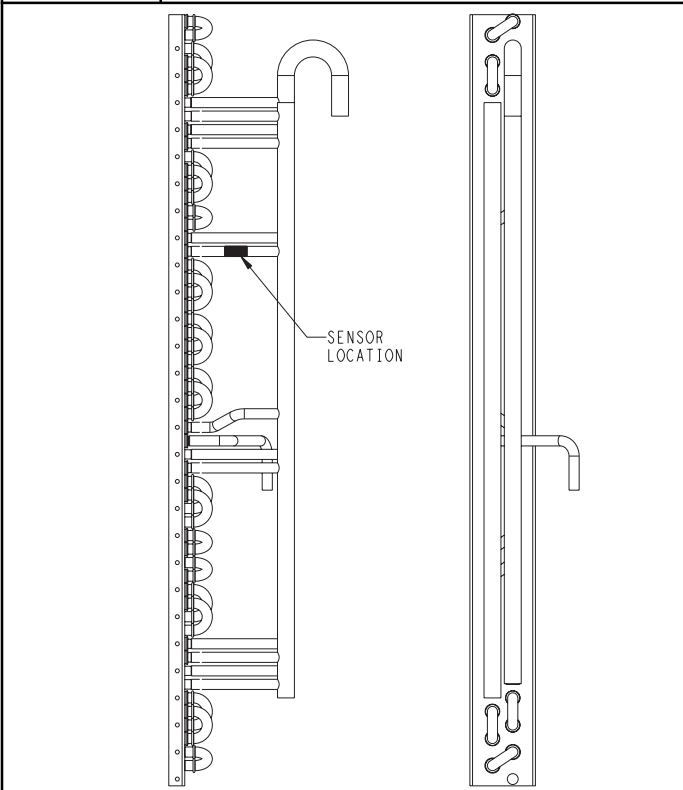
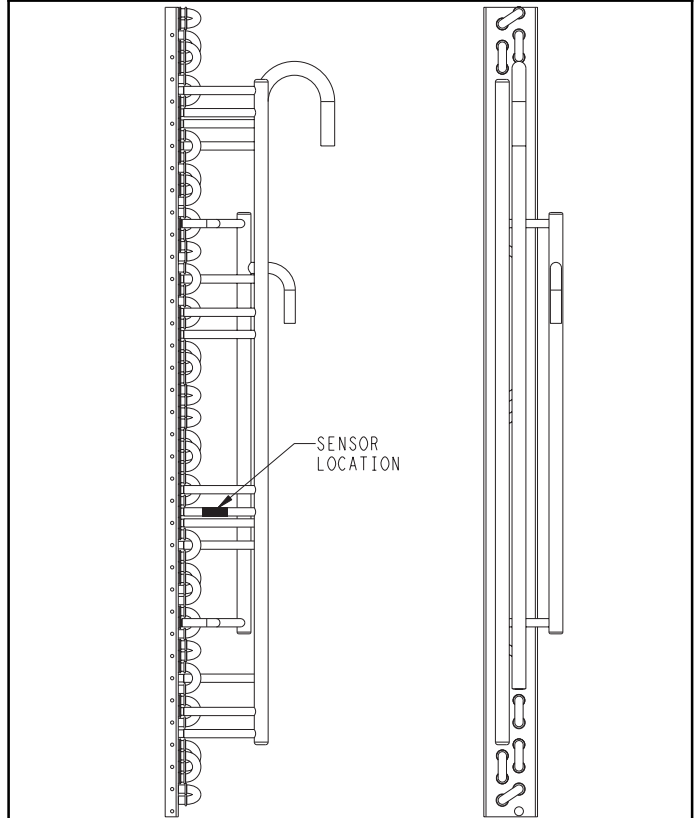

FIGURE 50 RGS091, Outdoor Circuited



APPENDIX VI. MOTORMASTER SENSOR LOCATIONS (CONT.)

FIGURE 51

RGS101 – 121, Outdoor Circuiting

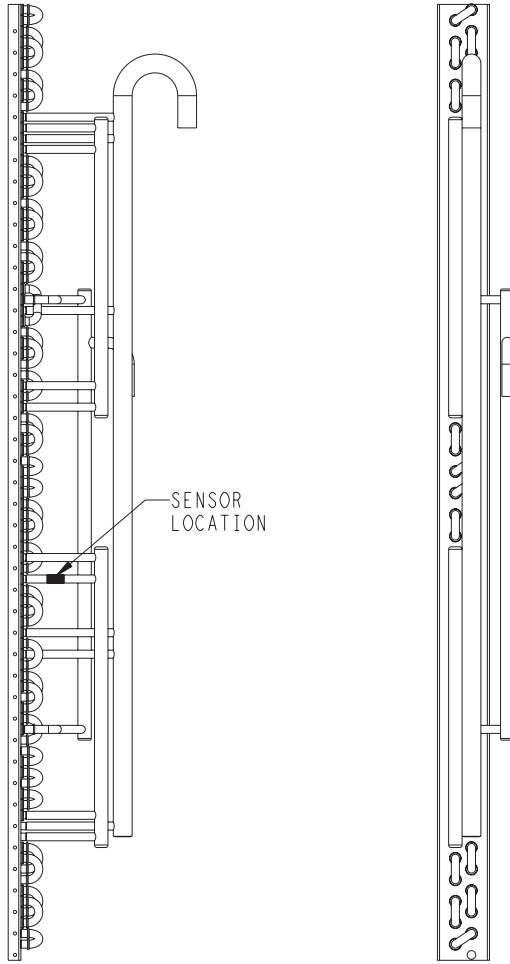

START-UP CHECKLIST

(Remove and Store in Job File)

I. PRELIMINARY INFORMATION

MODEL NO.: _____ SERIAL NO.: _____
DATE: _____ TECHNICIAN: _____
BUILDING LOCATION: _____

II. PRE-START-UP (insert checkmark in box as each item is completed)

- VERIFY THAT ALL PACKAGING MATERIALS HAVE BEEN REMOVED FROM UNIT
- VERIFY THAT CONDENSATE CONNECTION IS INSTALLED PER INSTALLATION INSTRUCTIONS
- VERIFY THAT FLUE HOOD IS INSTALLED
- CHECK ALL ELECTRICAL CONNECTIONS AND TERMINALS FOR TIGHTNESS
- CHECK TO ENSURE NO WIRES ARE TOUCHING REFRIGERANT TUBING OR SHARP EDGES
- CHECK GAS PIPING FOR LEAKS
- CHECK THAT RETURN-AIR FILTER IS CLEAN AND IN PLACE
- VERIFY THAT UNIT INSTALLATION IS LEVEL
- CHECK FAN WHEEL AND PROPELLER FOR LOCATION IN HOUSING/ORIFICE AND VERIFY SETSCREW IS TIGHT
- VERIFY PULLEY ALIGNMENT AND BELT TENSION ARE CORRECT

III. START-UP

ELECTRICAL

SUPPLY VOLTAGE	L1-L2	_____	L2-L3	_____	L3-L1	_____
COMPRESSOR AMPS	L1	_____	L2	_____	L2	_____
INDOOR FAN AMPS	L1	_____	L2	_____	L2	_____

TEMPERATURES

OUTDOOR-AIR TEMPERATURE	_____	DB	_____	WB
RETURN-AIR TEMPERATURE	_____	DB	_____	WB
COOLING SUPPLY AIR	_____	DB	_____	WB
GAS HEAT SUPPLY AIR	_____	DB		

PRESSURES

GAS INLET PRESSURE	_____	IN. WG		
GAS MANIFOLD PRESSURE	_____	IN. WG (LOW FIRE)	_____	IN. WG (HI FIRE)
REFRIGERANT SUCTION	_____	PSIG	_____	TEMP °F
REFRIGERANT DISCHARGE	_____	PSIG	_____	TEMP °F

- VERIFY PULLEY ALIGNMENT AND BELT TENSION ARE CORRECT
- VERIFY REFRIGERANT CHARGE USING CHARGING CHARTS
- VERIFY THAT 3-PHASE SCROLL COMPRESSOR IS ROTATING IN CORRECT DIRECTION