

Maintenance

⚠ WARNING

Hazardous Service Procedures!

Failure to follow all precautions in this manual and on the tags, stickers, and labels could result in death or serious injury.

Technicians, in order to protect themselves from potential electrical, mechanical, and chemical hazards, **MUST** follow precautions in this manual and on the tags, stickers, and labels, as well as the following instructions: Unless specified otherwise, disconnect all electrical power including remote disconnect and discharge all energy storing devices such as capacitors before servicing. Follow proper lockout/tagout procedures to ensure the power can not be inadvertently energized. When necessary to work with live electrical components, have a qualified licensed electrician or other individual who has been trained in handling live electrical components perform these tasks.

Fan Belt Adjustment - Belt Drive Units

⚠ WARNING

Live Electrical Components!

Failure to follow all electrical safety precautions when exposed to live electrical components could result in death or serious injury. When necessary to work with live electrical components, have a qualified licensed electrician or other individual who has been properly trained in handling live electrical components perform these tasks.

⚠ WARNING

Rotating Components!

Failure to follow all safety precautions below could result in rotating components cutting and slashing technician which could result in death or serious injury. During installation, testing, servicing and troubleshooting of this product it may be necessary to work with live and exposed rotating components. Have a qualified or licensed service individual who has been properly trained in handling exposed rotating components, perform these tasks.

The fan belts must be inspected periodically to assure proper unit operation.

Replacement is necessary if the belts appear frayed or worn. Units with dual belts require a matched set of belts to ensure equal belt length.

When removing or installing the new belts, do not stretch them over the sheaves. Loosen the belts using the belt tension adjustment bolts on the motor mounting base.

Once the new belts are installed, using a Browning or Gates tension gauge (or equivalent) illustrated in [Figure 70, p. 66](#); adjust the belt tension as follows;

- To determine the appropriate belt deflection;
 - Measure the center-to-center shaft distance (in inches) between the fan and motor sheaves.
 - Divide the distance measured in Step 1a by 64; the resulting value represents the amount of belt deflection that corresponds to the proper belt tension.
- Set the large O-ring on the belt tension gauge at the deflection value determined in Step 1b.
- Set the small O-ring at zero on the force scale of the gauge plunger.
- Place the large end of the gauge at the center of the belt span; then depress the gauge plunger until the large O-ring is even with the top of the next belt or even with a straightedge placed across the fan and motor sheaves. Refer to [Figure 70, p. 66](#).
- Remove the belt tension gauge. The small O-ring now indicates a number other than zero on the plunger's force scale. This number represents the force (in pounds) required to give the needed deflection.
- Compare the "force" scale reading (Step 5) with the appropriate "force" value listed in [Table 19, p. 67](#). If the "force" reading is outside the range, readjust the belt tension.

Note: Actual belt deflection "force" must not exceed the maximum "force" value shown in [Figure 70, p. 66](#).

- Recheck the belt tension at least twice during the first 2 to 3 days of operation. Belt tension may decrease until the new belts are "run in".

Figure 70. Belt tension gauge

$$\text{Deflection} = \frac{\text{Belt Span (in)}}{64}$$

$$\text{Deflection} = \frac{\text{Belt Span (mm)}}{152}$$

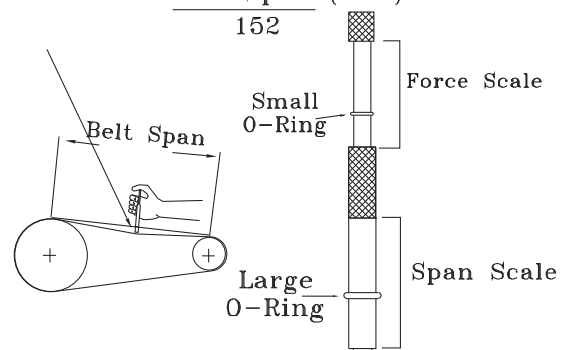

Table 19. Belt tension measurement and deflection

Belts Cross Section	Small P.D Range	Deflection Force (Lbs.)					
		Super Gripbelts		Gripnotch		Steel Cable Gripbelts	
		Min.	Max.	Min.	Max.	Min.	Max.
A	3.0 - 3.6	3	4 1/2	3 7/8	5 1/2	3 1/4	4
	3.8 - 4.8	3 1/2	5	4 1/2	6 1/4	3 3/4	4 3/4
	5.0 - 7.0	4	5 1/2	5	6 7/8	4 1/4	5 1/4
B	3.4 - 4.2	4	5 1/2	5 3/4	8	4 1/2	5 1/2
	4.4 - 5.6	5 1/8	7 1/8	6 1/2	9 1/8	5 3/4	7 1/4
	5.8 - 8.8	6 3/8	8 3/4	7 3/8	10 1/8	7	8 3/4

Monthly Maintenance

⚠ WARNING

Hazardous Voltage!

Failure to disconnect power before servicing could result in death or serious injury. Disconnect all electric power, including remote disconnects before servicing. Follow proper lockout/tagout procedures to ensure the power can not be inadvertently energized.

Before completing the following checks, turn the unit OFF and lock the main power disconnect switch open.

Filters

Inspect the return air filters. Clean or replace them if necessary. Refer to the unit Service Facts for filter information.

Return Air Smoke Detector Maintenance

Airflow through the unit is affected by the amount of dirt and debris accumulated on the indoor coil and filters. To insure that airflow through the unit is adequate for proper sampling by the return air smoke detector, complete adherence to the maintenance procedures, including recommended intervals between filter changes, and coil cleaning is required.

Periodic checks and maintenance procedures must be performed on the smoke detector to insure that it will function properly. For detailed instructions concerning these checks and procedures, refer to the appropriate section(s) of the smoke detector Installation and Maintenance Instructions provided with the literature package for this unit.

Cooling Season

- Check the unit’s drain pans and condensate piping to ensure that there are no blockages.
- Inspect the evaporator and condenser coils for dirt, bent fins, etc. If the coils appear dirty, clean them

according to the instructions described in “Coil Cleaning” later in this section.

- Manually rotate the condenser fan(s) to ensure free movement and check motor bearings for wear. Verify that all of the fan mounting hardware is tight.
- Inspect the F/A-R/A damper hinges and pins to ensure that all moving parts are securely mounted. Keep the blades clean as necessary.
- Verify that all damper linkages move freely; lubricate with white grease, if necessary.
- Check supply fan motor bearings; repair or replace the motor as necessary.
- Check the fan shaft bearings for wear. Replace the bearings as necessary.
- Check the supply fan belt. If the belt is frayed or worn, replace it. Refer to the “Fan Belt Adjustment” section for belt replacement and adjustments.
- Verify that all wire terminal connections are tight.
- Remove any corrosion present on the exterior surfaces of the unit and repaint these areas.
- Generally inspect the unit for unusual conditions (e.g., loose access panels, leaking piping connections, etc.)
- Make sure that all retaining screws are reinstalled in the unit access panels once these checks are complete.
- With the unit running, check and record the: ambient temperature; compressor suction and discharge pressures (each circuit); superheat (each circuit);
- Record this data on an “operator’s maintenance log” like the one shown in Table 20, p. 69. If the operating pressures indicate a refrigerant shortage, measure the system superheat. For guidelines, refer to the “Compressor Start-Up” section.

Important: *Do not release refrigerant to the atmosphere! If adding or removing refrigerant is required, the service technician must comply with all federal, state and local laws.*

Heating Season

- Inspect the unit’s air filters. If necessary, clean or replace them.
- Check supply fan motor bearings; repair or replace the motor as necessary.
- Inspect both the main unit control panel and heat section control box for loose electrical components and terminal connections, as well as damaged wire insulation. Make any necessary repairs.
- Verify that the electric heat system operates properly.

Coil Cleaning

Regular coil maintenance, including annual cleaning, enhances the unit’s operating efficiency by minimizing:

Maintenance

compressor head pressure and amperage draw; evaporator water carryover; fan brake horsepower, due to increase static pressure losses; airflow reduction.

At least once each year, or more often if the unit is located in a "dirty" environment, clean the evaporator and condenser coils using the instructions outlined below. Be sure to follow these instructions as closely as possible to avoid damaging the coils.

Note: For units equipped with hail guards follow removal procedure listed below.

Hail Guard Removal

- Unlatch hail guard.
- Pull the top of the hail guard outward until the fastener studs are free of the retaining nuts.
- Lift the hail guard from the lower retaining bracket and set aside.

⚠ WARNING

Hazardous Chemicals!

Failure to follow all safety instructions below could result in death or serious injury. Coil cleaning agents can be either acidic or highly alkaline and can burn severely if contact with skin occurs. Handle chemical carefully and avoid contact with skin. ALWAYS wear Personal Protective Equipment (PPE) including goggles or face shield, chemical resistant gloves, boots, apron or suit as required. For personal safety refer to the cleaning agent manufacturer's Materials Safety Data Sheet and follow all recommended safe handling practices.

To clean refrigerant coils, use a soft brush and a sprayer (either a garden pump-up type or a high-pressure sprayer). A high-quality detergent is also required; suggested brands include "SPREX A.C.," "OAKITE 161," "OAKITE 166" and "COILOX." If the detergent selected is strongly alkaline (ph value exceeds 8.5), add an inhibitor.

Microchannel (MCHE) Coils

NOTICE:

Coil Damage!

Failure to follow instructions below could result in coil damage.

DO NOT use any detergents with microchannel condenser coils. Use pressurized water or air **ONLY**, with pressure no greater than 600psi.

For additional information regarding the proper microchannel coil cleaning procedure, refer to service bulletin RT-SVB83-EN.*

Due to the soft material and thin walls of the MCHE coils, the traditional field maintenance method recommended for Round Tube Plate Fin (RTPF) coils does not apply to microchannel coils.

Moreover, chemical cleaners are a risk factor to MCHE due to the material of the coil. The manufacturer does not recommend the use of chemical cleaners to clean microchannel coils. Using chemical cleaners could lead to warranty claims being further evaluated for validity and failure analysis.

The recommended cleaning method for microchannel condenser coils is pressurized water or air with a non-pinpoint nozzle and an ECU of at least 180 with pressure no greater than 600 psi. To minimize the risk of coil damage, approach the cleaning of the coil with the pressure washer aimed perpendicular to the face of the coil.

Note: For more details on Microchannel coil cleaning, please refer to bulletin RT-SVB83*-EN.

Round Tube Plate Fin (RTPF) Coils

⚠ WARNING

Hazardous Chemicals!

Failure to follow all safety instructions below could result in death or serious injury. Coil cleaning agents can be either acidic or highly alkaline and can burn severely if contact with skin occurs. Handle chemical carefully and avoid contact with skin. ALWAYS wear Personal Protective Equipment (PPE) including goggles or face shield, chemical resistant gloves, boots, apron or suit as required. For personal safety refer to the cleaning agent manufacturer's Materials Safety Data Sheet and follow all recommended safe handling practices.

1. Remove enough panels from the unit to gain access to the coil.
2. Protect all electrical devices such as motors and controllers from any over spray.
3. Straighten any bent coil fins with a fin comb.
4. Mix the detergent with water according to the manufacturer's instructions. If desired, heat the solution BUT DO NOT EXCEED 150°F maximum to improve its cleansing capability.

⚠ WARNING

Hazardous Pressures!

Failure to follow safety precautions below could result in coil bursting, which could result in death or serious injury. Coils contain refrigerant under pressure. When cleaning coils, maintain coil cleaning solution temperature under 150°F to avoid excessive pressure in the coil.

5. Pour the cleaning solution into the sprayer. If a high-pressure sprayer is used:
 - a. do not allow sprayer pressure to exceed 600 psi.
 - b. the minimum nozzle spray angle is 15 degrees.

- c. maintain a minimum clearance of 6" between the sprayer nozzle and the coil.
 - d. spray the solution perpendicular (at 90 degrees) to the coil face.
6. Spray the leaving-airflow side of the coil first; then spray the opposite side of the coil. Allow the cleaning solution to stand on the coil for five minutes.
 7. Rinse both sides of the coil with cool, clean water.
 8. Inspect both sides of the coil; if it still appears to be dirty, repeat Steps 6 and 7.
 9. Reinstall all of the components and panels removed in Step 1 and any protective covers installed in step 2.

Note: For units equipped with hail guards follow reinstallation procedure listed below.

Hail Guard Reinstallation

To reinstall the hail guard, locate the bottom of the hail guard in the lower bracket and secure it to the upper unit bracket with the attached fasteners.

Note: Secure hail guard latches.

Figure 71. Hail guard

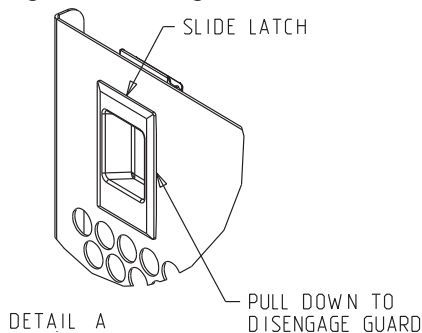

10. Restore the unit to its operational status and check system operation.

Table 20. Sample maintenance log

Date	Current Ambient Temp. F/C	Refrigerant Circuit #1						Refrigerant Circuit #2					
		Compr. Oil Level	Suct. Press. Psig/kPa	Disch. Press. Psig/kPa	Liquid Press. Psig/kPa	Super-heat F/C	Sub-cool. F/C	Compr. Oil Level	Suct. Press. Psig/kPa	Disch. Press. Psig/kPa	Liquid Press. Psig/kPa	Super-heat F/C	Sub-cool. F/C
		- ok - low						- ok - low					
		- ok - low						- ok - low					
		- ok - low						- ok - low					
		- ok - low						- ok - low					
		- ok - low						- ok - low					

Note: Check and record the data requested above each month during the cooling season with the unit running.

Annual Maintenance

Clean and repaint any corroded surface.

Final Process

For future reference, you may find it helpful to record the unit data requested in the blanks provided.

Complete Model Number: _____

Unit Serial Number: _____

Wiring Diagram Numbers (from unit control panel): _____

Connections: _____

Schematics: _____

Troubleshooting

⚠ WARNING

Hazardous Service Procedures!

Failure to follow all precautions in this manual and on the tags, stickers, and labels could result in death or serious injury.

Technicians, in order to protect themselves from potential electrical, mechanical, and chemical hazards, **MUST** follow precautions in this manual and on the tags, stickers, and labels, as well as the following instructions: Unless specified otherwise, disconnect all electrical power including remote disconnect and discharge all energy storing devices such as capacitors before servicing. Follow proper lockout/tagout procedures to ensure the power can not be inadvertently energized. When necessary to work with live electrical components, have a qualified licensed electrician or other individual who has been trained in handling live electrical components perform these tasks.

ReliaTel™ Control

The RTRM has the ability to provide the service personnel with some unit diagnostics and system status information.

Before turning the main power disconnect switch “Off”, follow the steps below to check the ReliaTel Refrigeration Module (RTRM). All diagnostics & system status information stored in the RTRM will be lost when the main power is turned “Off”.

⚠ WARNING

Live Electrical Components!

Failure to follow all electrical safety precautions when exposed to live electrical components could result in death or serious injury. When necessary to work with live electrical components, have a qualified licensed electrician or other individual who has been properly trained in handling live electrical components perform these tasks.

To prevent injury or death from electrocution, it is the responsibility of the technician to recognize this hazard and use extreme care when performing service procedures with the electrical power energized.

1. Verify that the Liteport LED on the RTRM is burning continuously. If the LED is lit, go to [Step 3](#).
2. If the LED is not lit, verify that 24 VAC is presence between J1-1 and J1-2. If 24 VAC is present, proceed to [Step 4](#). If 24 VAC is not present, check the unit main power supply, check transformer (TNS1). Proceed to [Step 3](#) if necessary.
3. Utilizing “Method 1” or “Method 2” in the “System Status Diagnostic” section, check the following:
 - System status

- Heating status
- Cooling status

If a System failure is indicated, proceed to [Step 4](#). If no failures are indicated, proceed to [Step 5](#).

4. If a System failure is indicated, recheck [Step 1](#) and [Step 2](#). If the LED is not lit in [Step 1](#), and 24 VAC is present in [Step 2](#), the RTRM has failed. Replace the RTRM.
5. If no failures are indicated, use one of the TEST mode procedures described in the “Unit Start-Up” section to start the unit. This procedure will allow you to check all of the RTRM outputs, and all of the external controls (relays, contactors, etc.) that the RTRM outputs energize, for each respective mode. Proceed to [Step 6](#).
6. Step the system through all of the available modes, and verify operation of all outputs, controls, and modes. If a problem in operation is noted in any mode, you may leave the system in that mode for up to one hour while troubleshooting. Refer to the sequence of operations for each mode, to assist in verifying proper operation. Make the necessary repairs and proceed to [Step 7](#) and [Step 8](#).
7. If no abnormal operating conditions appear in the test mode, exit the test mode by turning the power “Off” at the main power disconnect switch.
8. Refer to the individual component test procedures if other microelectronic components are suspect.

System Status Checkout Procedure

“System Status” is checked by using one of the following two methods:

Method 1

If the Zone Sensor Module (ZSM) is equipped with a remote panel with LED status indication, you can check the unit within the space. If the ZSM does not have LED’s, use Method 2. BAYSENS110*, BAYSENS109*, BAYSENS119*, BAYSENS023A all have the remote panel indication feature. The LED descriptions are listed below.

Zone Sensor LED 1 (System)

“On” during normal operation.

“Off” if a system failure occurs or the LED fails.

“Flashing” indicates test mode.

Zone Sensor LED 2 (Heat)

“On” when the heat cycle is operating.

“Off” when the heat cycle terminates or the LED fails.

“Flashing” indicates a heating failure.

Zone Sensor LED 3 (Cool)

“On” when the cooling cycle is operating.

“Off” when the cooling cycle terminates or the LED fails.

“Flashing” indicates a cooling failure.

Zone Sensor LED 4 (Service)

“On” indicates a clogged filter.

“Off” during normal operation.

“Flashing” indicates an evaporator fan or condensate overflow failure.

Below is the complete listing of failure indication causes.

System failure

Check the voltage between terminals 6 and 9 on J6, it should read approximately 32 VDC. If no voltage is present, a System failure has occurred. Refer to Step 4 in the previous section for the recommended troubleshooting procedure.

Cooling Failure

- Cooling and heating set point (slide pot) on the zone sensor has failed. Refer to the “Zone Sensor Test Procedure” section.
- Zone temperature thermistor ZTEMP on ZTS failed. Refer to the “Zone Sensor Test Procedure” section.
- CC1 or CC2 24 VAC control circuit has opened, check CC1 & CC2 coils, and any of the controls below that apply to the unit (HPC1, HPC2).
- LPC1 has opened during the 3 minute minimum “on time” during 4 consecutive compressor starts, check LPC1 or LPC2 by testing voltage between the J1-1 & J3-2 terminals on the RTRM and ground. If 24 VAC is present, the LPC’s has not tripped. If no voltage is present, LPC’s has tripped.

Service Failure

- If the supply fan proving switch has closed, the unit will not operate (when connected to RTOM), check the fan motor, belts, and proving switch.
- Clogged filter switch has closed, check the filters.
- If the condensate overflow switch is closed, the unit will not operate. Make sure the float switch is not in a tripped condition, and check for an “open” between wires connecting to RTOM J6-1, J6-2 (ReliaTel™ controls).

Simultaneous Heat and Cool Failure

- Emergency Stop is activated

Method 2

The second method for determining system status is done by checking voltage readings at the RTRM (J6). The system indication descriptions and the approximate voltages are listed below.

System Failure

- Measure the voltage between terminals J6-9 & J6-6.
- Normal Operation = approximately 32 VDC
- System Failure = less than 1 VDC, approximately 0.75 VDC
- Test Mode = voltage alternates between 32 VDC & 0.75 VDC

Heat Failure

- Measure the voltage between terminals J6-7 & J6-6.
- Heat Operating = approximately 32 VDC
- Heat Off = less than 1 VDC, approximately 0.75 VDC
- Heating Failure = voltage alternates between 32 VDC & 0.75 VDC

Cool Failure

- Measure the voltage between terminals J6-8 & J6-6.
- Cool Operating = approximately 32 VDC
- Cool Off = less than 1 VDC, approximately 0.75 VDC
- Cooling Failure = voltage alternates between 32 VDC & 0.75 VDC

Service Failure

- Measure the voltage between terminals J6-10 & J6-6.
- Clogged Filter = Approximately 32 VDC.
- Normal = Less than 1 VDC, approximately 0.75 VDC
Fan Failure = voltage alternates between 32 VDC & 0.75 VDC.

To use LED’s for quick status information at the unit, purchase a BAYSENS110* ZSM and connect wires with alligator clamps to terminals 6 through 10. Connected each respective terminal wire (6 through 10) from the Zone Sensor to the unit J6 terminals 6 through 10.

Note: *If the system is equipped with a programmable zone sensor, (BAYSENS119*, or BAYSENS023A), the LED indicators will not function while the BAYSENS110* is connected.*

Resetting Cooling and Ignition Lockouts

Cooling Failures and Heating Lockouts are reset in an identical manner. Method 1 explains resetting the system from the space; Method 2 explains resetting the system at the unit.

Note: *Before resetting Cooling Failures and Ignition Lockouts check the Failure Status Diagnostics by the methods previously explained. Diagnostics will be lost when the power to the unit is disconnected.*

Method 1

To reset the system from the space, turn the “Mode” selection switch at the zone sensor to the “Off” position. After approximately 30 seconds, turn the “Mode”

Troubleshooting

selection switch to the desired mode, i.e. Heat, Cool or Auto.

Method 2

To reset the system at the unit, cycle the unit power by turning the disconnect switch “Off” and then “On”.

Lockouts can be cleared through the building management system. Refer to the building management system instructions for more information.

Zone Temperature Sensor (ZTS) Service Indicator

The ZSM SERVICE LED is a generic indicator, that will signal the closing of a Normally Open switch at any time, providing the Indoor Motor (IDM) is operating. This indicator is usually used to indicate a clogged filter, or an air side fan failure.

The RTRM will ignore the closing of this Normally Open switch for 2 (±1) minutes. This helps prevent nuisance SERVICE LED indications. The exception is the LED will flash 40 seconds after the fan is turned “On” if the Fan Proving Switch is not made.

Clogged Filter Switch

This LED will remain lit the entire time that the Normally Open switch is closed. The LED will be turned off immediately after resetting the switch (to the Normally Open position), or any time that the IDM is turned “Off”.

If the switch remains closed, and the IDM is turned “On”, the SERVICE LED will be turned “On” again after the 2 (±1) minute ignore delay.

This LED being turned “On”, will have no other affect on unit operation. It is an indicator only.

Fan Failure Switch

When the “Fan Failure” switch is wired to the RTOM, the LED will remain flashing the entire time the fan proving switch is closed, indicating a fan failure, and it will shut the unit operations down.

Condensate Overflow Switch

When the “Condensate Overflow Switch” is closed, a drain pan overflow condition is indicated and it will shut unit operations down.

Zone Temperature Sensor (ZTS) Test

Note: *These procedures are not for programmable or digital models and are conducted with the Zone Sensor Module electrically removed from the system.*

Test 1 - Zone Temperature Thermistor (ZTEMP)

This component is tested by measuring the resistance between terminals 1 and 2 on the Zone Temperature Sensor. Below are some typical indoor temperatures, and corresponding resistive values.

Test 2 - Cooling Set Point (CSP) and Heating Set Point (HSP)

Table 21. Cooling setpoint and heating setpoint

Zone Temperature		Nominal ZTEMP Resistance
50° F	10.0°C	19.9 K-Ohms
55° F	12.8°C	17.47 K-Ohms
60° F	15.6°C	15.3 K-Ohms
65° F	18.3°C	13.49 K-Ohms
70° F	21.1°C	11.9 K-Ohms
75° F	23.9°C	10.50 K-Ohms
80° F	26.7°C	9.3 K-Ohms
85° F	29.4°C	8.25 K-Ohms
90° F	32.2°C	7.3 K-Ohms

The resistance of these potentiometers are measured between the following ZSM terminals. Refer to the chart above for approximate resistances at the given setpoints.

Cool SP = Terminals 2 and 3

Range = 100 to 900 Ohms approximate

Heat SP = Terminals 2 and 5

Range = 100 to 900 Ohms approximate

Test 3 - System Mode and Fan Selection

The combined resistance of the Mode selection switch and the Fan selection switch can be measured between terminals 2 and 4 on the Zone Sensor. The possible switch combinations are listed below with their corresponding resistance values.

Test 4 - LED Indicator Test, (SYS ON, HEAT, COOL & SERVICE)

Method 1

Testing the LED using a meter with diode test function. Test both forward and reverse bias. Forward bias should measure a voltage drop of 1.5 to 2.5 volts, depending on your meter. Reverse bias will show an Over Load, or open circuit indication if LED is functional.

Method 2

Testing the LED with an analog Ohmmeter. Connect Ohmmeter across LED in one direction, then reverse the leads for the opposite direction. The LED should have at least 100 times more resistance in reverse direction, as compared with the forward direction. If high resistance in

both directions, LED is open. If low in both directions, LED is shorted.

Method 3

To test LED's with ZSM connected to unit, test voltages at LED terminals on ZSM. A measurement of 32 VDC, across an unlit LED, means the LED has failed.

Relative Humidity Sensor Test

This component is measured by measuring the mA output signal on the Relative Humidity Sensor. Verify accuracy of the sensor annually. If the output reading is 0 mA, first verify that power is applied to the sensor. A reading of 4 mA corresponds to 0% RH and 20 mA corresponds to 100% RH.

% RH	mA
30	8.8
40	10.4
50	12.0
60	13.6
70	15.2
80	16.8

Note: Measurements should be made from LED common (ZSM terminal 6 to respective LED terminal). Refer to the Zone Sensor Module (ZSM) Terminal Identification table at the beginning of this section.

Programmable & Digital Zone Sensor Test

Testing serial communication voltage

1. Verify 24 VAC is present between terminals J6-14 & J6-11.
2. Disconnect wires from J6-11 and J6-12. Measure the voltage between J6-11 and J6-12, should be about 32 VDC.
3. Reconnect wires to terminals J6-11 and J6-12. Measure voltage again between J6-11 and J6-12, voltage should flash high and low every 0.5 seconds. The voltage on the low end will measure about 19 VDC, while the voltage on the high end will measure from approximately 24 to 38 VDC.
4. Verify all modes of operation, by running the unit through all of the steps in [Table 11, p. 48](#).
5. After verifying proper unit operation, exit the test mode. Turn the fan on continuously at the ZSM, by pressing the button with the fan symbol. If the fan comes on and runs continuously, the ZSM is good. If you are not able to turn the fan on, the ZSM is defective.

ReliaTel™ Refrigeration Module (RTRM) Default Chart

If the RTCL loses input from the building management system, the RTRM will control in the default mode after approximately 15 minutes. If the RTRM loses the Heating and Cooling setpoint input, the RTRM will control in the default mode instantaneously. The temperature sensing thermistor in the Zone Sensor Module is the only component required for the "Default Mode" to operate.

Unit Operation without a Zone Sensor

This procedure is for temporary operation only. The economizer and condenser fan cycling functions are disabled.

⚠ WARNING

Hazardous Voltage!

Failure to disconnect power before servicing could result in death or serious injury. Disconnect all electric power, including remote disconnects before servicing. Follow proper lockout/tagout procedures to ensure the power can not be inadvertently energized.

1. Open and Lock the unit disconnect switch.
2. Remove the Outside Air Sensor (OAS) from the condenser section of unit.
3. Use two (2) wire nuts, to individually cap the wires.
4. Locate the RTRM (J6). Connect two (2) wires to terminals J6-1 and 2.
5. Connect the sensor (OAS) using two wire nuts to the two (2) field supplied wires that were connected to terminals 1 and 2 on J6.

Unit Economizer Control (ECA) Troubleshooting

ReliaTel™ Control

Verify Economizer Status by Economizer Actuator (ECA) LED indicator:

- OFF: No Power or Failure
- ON: Normal, OK to Economize
- Slow Flash: Normal, Not OK to Economize
- Fast Flash - 1/2 Second On / 2 Seconds Off:
 - Error Code: Communications Failure
- Pulse Flash: 2 Seconds On / 1/2 Second Off:
 - Error Code:
 - 1 Flash: Actuator Fault
 - 2 Flashes: CO₂ Sensor
 - 3 Flashes: RA Humidity Sensor
 - 4 Flashes: RA Temp Sensor

Troubleshooting

- 5 Flashes: OA Quality Sensor
- 6 Flashes: OA Humidity Sensor
- 7 Flashes: OA Temp Sensor
- 8 Flashes: MA Temp Sensor
- 9 Flashes: RAM Fault
- 10 Flashes: ROM Fault
- 11 Flashes: EEPROM Fault

Electromechanical Control

⚠ WARNING

Live Electrical Components!

Failure to follow all electrical safety precautions when exposed to live electrical components could result in death or serious injury. When necessary to work with live electrical components, have a qualified licensed electrician or other individual who has been properly trained in handling live electrical components perform these tasks.

To prevent injury or death from electrocution, it is the responsibility of the technician to recognize this hazard

and use extreme care when performing service procedures with the electrical power energized.

Cooling Failure

1. Cooling and heating set point (slide pot) on the thermostat has failed.
2. CC1 or CC2 24 VAC control circuit has opened, check CC1 & CC2 coils, and any of the controls below that apply to the unit (HPC1, HPC2, LPC1, LPC2, Froststat™).

Resetting Cooling and Heating Lockouts

Cooling Failures and Heating Lockouts are reset in an identical manner. Method 1 explains resetting the system from the space; Method 2 explains resetting the system at the unit.

Method 1

To reset the system from the space, turn the “Mode” selection switch at the thermostat to the “Off” position. After approximately 30 seconds, turn the “Mode” selection switch to the desired mode, i.e. Heat, Cool or Auto.

Method 2

To reset the system at the unit, cycle the unit power by turning the disconnect switch “Off” and then “On”.

Table 22. Fault detection and diagnostic codes

Failures	Primary Fault Codes								Information Code		
	Mixed Air Temp Sensor Fail	Outdoor Temp Sensor Fail	Economizer Actuator Fault	RTEM Comm Fail	Pressure Dead band Fail (If Used)	Temp Sensor Fail (If Used)	Airflow Sensor Fail (If Used)	Space Press Dead band Fail (If Used)	Unit Fails to Economize	Unit Economizing When It Should Not	Damper Position % Indicated
Damper stuck at Minimum			X		X ^(a)		X ^{(a)*}	X ^(a)	X		X
Damper Stuck Open			X		X ^(a)		X ^(a)	X ^(a)		X	X
Mixed Sensor Failure	X										X
Supply Air Sensor Failure						X					X
Outdoor Air Temperature Fail		X									X
Power loss to RTEM				X							
Failed or Power Loss to Actuator			X								X
Mechanical Failure of Actuator							X				

(a) If goes out of range.

Table 23. Low leak economizer sensor values

Sensor Values Data					
Temp °F	Resistance (K ohms)	Temp °F	Resistance (K ohms)	Temp °F	Resistance (K ohms)
40	26.097	54	17.847	68	12.435
41	25.383	55	17.382	69	12.126
42	24.690	56	16.930	70	11.827
43	24.018	57	16.491	71	11.535
44	23.367	58	16.066	72	11.252
45	22.736	59	15.654	73	10.977
46	22.132	60	15.253	74	10.709
47	21.530	61	14.864	75	10.448
48	20.953	62	14.486	76	10.194
49	20.396	63	14.119	77	9.949
50	19.854	64	13.762	78	9.710
51	19.330	65	13.416	79	9.477
52	18.821	66	13.078	80	9.250
53	18.327	67	12.752	81	9.030

Unit Economizer Control (ECA) Test Procedures

Electromechanical Control

This series of tests will allow you to diagnose, and determine where, and if a problem exists in the system economizer operation. Test 1 determines if the problem is in the Unit, or if it is in the ECA. Test 2 tests sensor inputs. Test 3 tests the resistors and sensors. Conduct the tests in numerical order until problem is found.

Test 1

Verifying that the economizer actuator (ECA) is functional:

- Using the "Test Mode" described in the "System Start-Up" section, put the unit into the economizer mode and verify that the economizer actuator (ECA) drives fully open (approximately 90 seconds).
- If the ECA is not driving the dampers, verify that 24 VAC is between the ECA terminals TR and TR1 is present. If 24 volts is not present, a wiring or terminal problem exists from the control transformer. Make any necessary repairs, see wiring diagrams to troubleshoot.
- If 24 VAC is present, adjust the minimum position potentiometer fully clockwise. If the actuator does not drive, the economizer actuator is bad. Replace the ECA.

Test 2

Testing the ECA resistors and sensors

- Testing the Mixed Air Sensor (MAS). Disconnect the wires connected to T and T1 on the ECA, and;

- Measure the resistance of the sensor between the wires 180B and 181B.
- Measure the temperature at the MAS location. Using the Temperature versus Resistance chart, verify the accuracy of the MAS.

Replace the sensor if it is out of range.

- Testing the Outdoor Air Switch. If the temperature is above 60 degrees, it will need to be chilled. Measure the resistance of the sensor on the ECA SO and +. The resistance should be approximately 390 Ohms. Replace the Switch if it is open. Replace the ECA if it is out of range.
- Testing the R1 Resistance. Measure the resistance of the sensor on the ECA SR and +. The resistance should be approximately 420 Ohms. Replace the ECA if it is out of range.
- Testing the R2 Resistance. Measure the resistance of the sensor on the ECA P and P1. The resistance should be approximately 130 Ohms. Replace the ECA if it is out of range.

Troubleshooting procedures for Direct Drive Plenum Fan

Prior to troubleshooting, verify all wiring and wiring connections. The motor has internal protections that will shut down the motor before damage occurs. A power cycle is required to reset some of the internal protections. Before proceeding, power down unit for 1 minute and then power on.

Please follow steps sequentially unless directed differently in solution.

Refer to RT-SVP08*-EN for a Comprehensive Troubleshooting Guide.

Unit Wiring Diagrams Numbers

Note: Wiring diagrams can be accessed using e-Library by entering the diagram number in the literature order number search field or by contacting technical support.

Table 24. Unit wiring diagram numbers

Schematic Type			Drawing Number	Description
Control	ReliaTel™	230,460,575V	1213-1640	TSC(036-060)G ReliaTel™ controls
Control	ReliaTel™	230,460,575V	4366-7216	THC(037-067)
Control	ReliaTel™	230,460,575V	4366-4568	T(S,H)C(036-060)E/F(1,3,4), ReliaTel Controls, X13 IDM
Control	ReliaTel™	230,460,575V	4366-1026	T(S,H)C(036-090)E/F(3,4,W), ReliaTel Controls, Belt-Drive IDM
Control	ReliaTel™	230,460,575V	1213-2388	TSC(072-090)H ReliaTel Cooling
Control	ReliaTel™	230,460,575V	1213-2390	TSC(092-120)H ReliaTel Cooling
Control	ReliaTel™	230,460,575V	4366-1044	TSC(092,102)F(3,4,W), ReliaTel Controls
Control	ReliaTel™	230,460,575V	4366-7433	THC(074-102)F(3,4),TSC120F(3,4,W), ReliaTel Controls
Control	ReliaTel™	230,460,575V	1213-2406	THC120F(3,4), ReliaTel Controls
Control	Electromechanical	230,460,575V	1213-1643	TSC(036-060)G Electromechanical Controls
Control	Electromechanical	230,460,575V	4366-8350	T(S,H)C(036-060)E,F(1,3,4), Electromechanical Controls, X13 IDM
Control	Electromechanical	230,460,575V	4366-8348	T(S,H)C(036-060)E,F(3,4,W), Electromechanical Controls, Belt-Drive IDM
Control	Electromechanical	230,460,575V	4366-8347	T(S,H)C(072,090)F(3,4,W), Electromechanical Controls
Control	Electromechanical	230,460,575V	1213-2413	TSC(072-120)H Electromechanical Cooling
Control	Electromechanical	230,460,575V	4366-8349	TSC(092,102)F(3,4,W), Electromechanical Controls
Control	Electromechanical	230,460,575V	4366-8352	THC(074-102)F(3,4),TSC120F(3,4,W), Electromechanical Controls
Control	Electromechanical	230,460,575V	1213-2405	THC120F(3,4), Electromechanical Controls
Power	ReliaTel	230V	1213-1636	TSC(036-060)G3, ReliaTel Controls
Power	ReliaTel	230V	4366-7177	THC(037-067) (230V)
Power	ReliaTel	230V	4366-4574	T(S,H)C(036-060)E,F (1-Phase)
Power	ReliaTel	230V	4366-5161	THC(036-060)E,F (3-Phase), X13 IDM
Power	ReliaTel	230V	4366-1037	TSC(092,102)F
Power	ReliaTel	230V	1213-2278	(THC074-102, TSC120)F (230V), ReliaTel Controls
Power	ReliaTel	230V	1213-2406	THC120F, ReliaTel Controls
Power	ReliaTel	460V and/or 575V	1213-1636	TSC(036-060)G4, ReliaTel Controls
Power	ReliaTel	460V and/or 575V	1213-1661	TSC(036-060)GW
Power	ReliaTel	460V and/or 575V	4366-7178	THC(037-067) (460V)
Power	ReliaTel	460V and/or 575V	4366-5161	THC(036-060)E,F (3-Phase), X13 IDM
Power	ReliaTel	460V and/or 575V	4366-1037	TSC(092,102)F
Power	ReliaTel	460V and/or 575V	1213-2278	(THC074-102, TSC120)F (460V), ReliaTel Controls
Power	ReliaTel	460V and/or 575V	1213-2279	TSC120F (575V), ReliaTel Controls
Power	ReliaTel	460V and/or 575V	4366-1020	T(YS,H)C(036-090)E3,4,W, ReliaTel™ Controls

Unit Wiring Diagrams Numbers

Table 24. Unit wiring diagram numbers (continued)

Schematic Type			Drawing Number	Description
Power	ReliaTel	460V and/or 575V	1213-2406	THC120F, ReliaTel Controls
Power	Electromechanical	230V	1213-1636	TSC(036-060)G3, Electromechanical Controls
Power	Electromechanical	230V	1213-2405	THC120F, Electromechanical Controls
Power	Electromechanical	230V	1213-2273	THC(074-102)F, TSC120, Electromechanical Controls
Power	Electromechanical	460V and/or 575V	1213-1636	TSC(036-060)G4, Electromechanical Controls
Power	Electromechanical	460V and/or 575V	1213-1661	TSC(036-060)GW
Power	Electromechanical	460V and/or 575V	1213-2405	THC120F, Electromechanical Controls
Power	Electromechanical	460V and/or 575V	1213-2273	THC(074-102)F4, TSC(120)F4, Electromechanical Controls
Power	Electromechanical	460V and/or 575V	1213-2274	TSC120FW, Electromechanical Controls
Power	Electromechanical	460V and/or 575V	4366-1020	T(YS,H)C(036-090)E3,4,W, Electromechanical Controls
Power	Electromechanical/ ReliaTel™	230,460,575V	1213-2384	TSC(072-120)H Constant Volume IDM
Power	Electromechanical/ ReliaTel™	230,460,575V	1213-2385	TSC(072-120)H Multispeed IDM, SZVAV, MZVAV
Connection	ReliaTel™	230V	1213-1668	TSC(036-060)G3, 230V ReliaTel Controls
Connection	ReliaTel™	230V	4366-7336	THC(037) (230V)
Connection	ReliaTel™	230V	4366-8243	THC037E, 17 Plus with Multi-Zone VAV
Connection	ReliaTel™	230V	4366-7338	THC(047-067) (230V)
Connection	ReliaTel™	230V	4366-8245	THC (047,067)E, 17 Plus with Multi-Zone VAV
Connection	ReliaTel™	230V	4366-8251	THC(074-120)E, ReliaTel Controls with Multi-Zone VAV
Connection	ReliaTel™	230V	4366-4559	T(S,H)C(036-060)E,F (1-Phase), ReliaTel Controls
Connection	ReliaTel™	230V	4366-5182	THC(036-060)E,F (3-Phase), ReliaTel Controls, X13 IDM
Connection	ReliaTel™	230V	4366-1509	T(S,H)C(036-060)E,F (3-Phase), ReliaTel Controls, Belt-Drive IDM
Connection	ReliaTel™	230V	4366-1541	T(S,H)C(072,090)F, ReliaTel Controls
Connection	ReliaTel™	230V	4366-7441	THC120F, ReliaTel Controls
Connection	ReliaTel™	230V	4366-1534	TSC(092,102)F, ReliaTel Controls
Connection	ReliaTel™	230V	4366-7443	THC(074-102)F, TSC120F, ReliaTel Controls
Connection	ReliaTel™	230V	4366-8252	THC(074-102)F, TSC120F, ReliaTel Controls with Multi-Zone VAV
Connection	ReliaTel™	460V and/or 575V	1213-1668	TSC(036-060)G4, 460V ReliaTel Controls
Connection	ReliaTel™	460V and/or 575V	1213-1670	TSC(036-060)GW, ReliaTel Controls
Connection	ReliaTel™	460V and/or 575V	4366-8252	THC(074-102)F, TSC120F, ReliaTel Controls with Multi-Zone VAV
Connection	ReliaTel™	460V and/or 575V	4366-7337	THC(037) (460V)
Connection	ReliaTel™	460V and/or 575V	4366-8244	THC037E, 17 Plus with Multi-Zone VAV
Connection	ReliaTel™	460V and/or 575V	4366-7339	THC(047-067) (460V)
Connection	ReliaTel™	460V and/or 575V	4366-8246	THC(047,067)E, 17 Plus with Multi-Zone VAV

Unit Wiring Diagrams Numbers

Table 24. Unit wiring diagram numbers (continued)

Schematic Type			Drawing Number	Description
Connection	ReliaTel™	460V and/or 575V	4366-5182	THC(036-060)E,F (3-Phase), ReliaTel Controls, X13 IDM
Connection	ReliaTel™	460V and/or 575V	4366-1509	T(S,H)C(036-060)E,F (3-Phase), ReliaTel Controls, Belt-Drive IDM
Connection	ReliaTel™	460V and/or 575V	4366-1541	T(S,H)C(072,090)F, ReliaTel Controls
Connection	ReliaTel™	460V and/or 575V	4366-7441	THC120F, ReliaTel Controls
Connection	ReliaTel™	460V and/or 575V	4366-8251	THC(074-120)E, ReliaTel Controls with Multi-Zone VAV
Connection	ReliaTel™	460V and/or 575V	4366-1534	TSC(092,102)F, ReliaTel Controls
Connection	ReliaTel™	460V and/or 575V	4366-7443	(THC074-102, TSC120)F, (460V), ReliaTel Controls
Connection	ReliaTel™	460V and/or 575V	4366-7445	TSC120F (575V), ReliaTel Controls
Connection	ReliaTel™	460V and/or 575V	4366-8253	TSC120F (575V), ReliaTel Controls with Multi-Zone VAV
Connection	ReliaTel™	230,460,575V	1213-2662	TSC(072-090)H ReliaTel
Connection	ReliaTel™	230,460,575V	1213-2663	TSC(092-120)H ReliaTel
Connection	Electromechanical	230V	1213-1669	TSC(036-060)G3, Electromechanical Controls
Connection	Electromechanical	230V	4366-8366	T(S,H)C(036-060)E,F (1-Phase), Electromechanical Controls
Connection	Electromechanical	230V	4366-8367	THC(036-060)E,F (3-Phase), Electromechanical Controls, X13 IDM
Connection	Electromechanical	230V	4366-8363	T(S,H)C(036-060)E,F (3-Phase), Electromechanical Controls, Belt-Drive IDM
Connection	Electromechanical	230V	4366-8365	T(S,H)C(072,090)F, Electromechanical Controls
Connection	Electromechanical	230V	4366-8368	THC120F, Electromechanical Controls
Connection	Electromechanical	230V	4366-8364	TSC(092,102)F, Electromechanical Controls
Connection	Electromechanical	230V	4366-8369	(THC074-102, TSC120)F, (230V), Electromechanical Controls
Connection	Electromechanical	230,460,575V	1213-2660	TSC(072-102)H Electromechanical
Connection	Electromechanical	230,460,575V	1213-2661	TSC(092-120)H Electromechanical
Connection	Electromechanical	460V and/or 575V	1213-1669	TSC(036-060)G4, Electromechanical Controls
Connection	Electromechanical	460V and/or 575V	1213-1671	TSC(036-060)GW, Electromechanical Controls
Connection	Electromechanical	460V and/or 575V	4366-8367	THC(036-060)E,F (3-Phase), Electromechanical Controls, X13 IDM
Connection	Electromechanical	460V and/or 575V	4366-8363	T(S,H)C(036-060)E,F (3-Phase), Electromechanical Controls, Belt-Drive IDM
Connection	Electromechanical	460V and/or 575V	4366-8365	T(S,H)C(072,090)F, Electromechanical Controls
Connection	Electromechanical	460V and/or 575V	4366-8368	THC120F, Electromechanical Controls
Connection	Electromechanical	460V and/or 575V	4366-8364	TSC(092,102)F, Electromechanical Controls
Connection	Electromechanical	460V and/or 575V	4366-8369	(THC074-102, TSC120)F (460V), Electromechanical Controls
Connection	Electromechanical	460V and/or 575V	4366-8370	TSC120F (575V), Electromechanical Controls