



# 15PJL

Parts List  
02-October-2017



*This parts list is current as of the above revision date.  
See <http://www.rheempartslists.net/92-42805-15PJL.pdf> for the current revision.*

Heat Pumps

# Table of Contents

Model Explanation .....	Page 3
<b>Parts Numbers</b>	
Panels - Miscellaneous (Granite-Steel Gray) .....	Page 4
Panels - Miscellaneous (Neutra Green) .....	Page 5
Electrical-Fan Group .....	Page 6
Coil Parts .....	Page 7
Compressor Group .....	Page 8
Accessories .....	Page 9
<b>Drawings/Photographs</b>	
Exploded View .....	Page 10
Control Box Assembly .....	Page 11
Valve Mounting Detail .....	Page 12
Notes/Disclaimer .....	Page 13

**MODEL NUMBER EXPLANATION**

1	5	P	J	L	1	8	A	0	1
1		2	3	4	5		6	7	

- |  |   |
|--|---|
| <p>(1) <b>SEER</b><br/>15 = SEER Rating</p> <p>(2) <b>MODEL</b><br/>P = Heat Pump</p> <p>(3) <b>VOLTAGE</b><br/>J = 208-230/1/60</p> <p>(4) <b>DESIGN SERIES</b></p> | <p>(5) <b>COOLING CAPACITY (BTU/HR)</b><br/>018= 18,000<br/>024= 24,000<br/>030= 30,000<br/>036= 36,000<br/>042= 42,000<br/>048= 48,000<br/>060= 60,000</p> <p>(6) <b>CABINET</b></p> <p>(7) <b>NAMEPLATE</b></p> |
|--|---|

**SERIAL NUMBER EXPLANATION**

7	9	7	8	W	0	2	1	0	9	9	9	9	9
1		2		3		4		5					

- (1) **COMPRESSOR IDENTIFICATION NUMBER**
- (2) **PRODUCTION LOCATION**
- (3) **WEEK OF PRODUCTION**
- (4) **YEAR OF PRODUCTION**
- (5) **PRODUCTION NUMBER**

No.	Notes	MODEL COOLING CAPACITY VARIATION	15PJL 18 A01	15PJL 24 A01	15PJL 30 A01	15PJL 36 A01
<b>SHEET METAL PARTS, MISCELLANEOUS (Granite/Steel Gray, After Date Code 4811)</b>						
1		Cabinet	AE-100726-82	AE-100726-82	AE-100726-83	AE-100726-84
2		Cabinet Panel	AE-100727-82	AE-100727-82	AE-100727-83	AE-100727-84
3		Base Pan	AS-100058-02	AS-100058-02	AE-101588-03	AE-101588-03
4		Control Box - 2 inch diameter capacitor	AE-100654-81	AE-100654-81	N/A	AE-100654-83
4		Control Box - 2-1/2 inch diameter capacitor	N/A	N/A	AE-100654-82	N/A
5		Control Box Cover	AE-100657-81	AE-100657-81	AE-100657-81	AE-100657-81
6		Top Panel	AE-100652-82	AE-100652-82	AE-100652-83	AE-100652-83
8		Grille	95-100906-03	95-100906-03	95-100906-04	95-100906-04
		Center Cap - Blank (for Grille)	91-101123-09	91-101123-09	91-101123-09	91-101123-09
12		Valve Mounting Panel	AE-57780-01	AE-57780-01	AE-57780-01	AE-100185-81
14		Service Valve - Suction	See Coil Group			
15		Service Valve - Liquid	See Coil Group			
17		Low Voltage Cover	AE-57756-01	AE-57756-01	AE-57756-01	AE-57756-01
		Touch-up Paint - Granite/Steel Gray (Aerosol)	PD523018	PD523018	PD523018	PD523018
		Touch-up Paint - Granite/Steel Gray (Paint Pens)	PD523019	PD523019	PD523019	PD523019

No.	Notes	MODEL COOLING CAPACITY VARIATION	15PJL 42 A01	15PJL 48 A01	15PJL 60 A01	
<b>SHEET METAL PARTS, MISCELLANEOUS (Granite/Steel Gray, After Date Code 4811)</b>						
1		Cabinet	AE-100726-84	AE-100726-84	AE-100726-84	
2		Cabinet Panel	AE-100727-84	AE-100727-84	AE-100727-84	
3		Base Pan	AE-101588-03	AE-101588-03	AE-101588-03	
4		Control Box - 2 inch diameter capacitor	AE-100654-83	N/A	N/A	
4		Control Box - 2-1/2 inch diameter capacitor	N/A	AE-100654-84	AE-100654-84	
5		Control Box Cover	AE-100657-81	AE-100657-81	AE-100657-81	
6		Top Panel	AE-100652-83	AE-100652-83	AE-100652-83	
8		Grille	95-100906-04	95-100906-04	95-100906-04	
		Center Cap - Blank (for Grille)	91-101123-09	91-101123-09	91-101123-09	
12		Valve Mounting Panel	AE-100185-81	AE-100185-81	AE-100185-81	
14		Service Valve - Suction	See Coil Group			
15		Service Valve - Liquid	See Coil Group			
17		Low Voltage Cover	AE-57756-01	AE-57756-01	AE-57756-01	
		Touch-up Paint - Granite/Steel Gray (Aerosol)	PD523018	PD523018	PD523018	
		Touch-up Paint - Granite/Steel Gray (Paint Pens)	PD523019	PD523019	PD523019	

No.	Notes	MODEL COOLING CAPACITY VARIATION	15PJL 18 A01	15PJL 24 A01	15PJL 30 A01	15PJL 36 A01
<b>SHEET METAL PARTS, MISCELLANEOUS (Neutra Green, Before Date Code 4811)</b>						
1		Cabinet	AE-100726-52	AE-100726-52	AE-100726-53	AE-100726-54
2		Cabinet Panel	AE-100727-52	AE-100727-52	AE-100727-53	AE-100727-54
3		Base Pan	AS-100058-02	AS-100058-02	AE-101588-03	AE-101588-03
4		Control Box - 2 inch diameter capacitor	AE-100654-51	AE-100654-51	AE-100654-51	AE-100654-53
4		Control Box - 2-1/2 inch diameter capacitor	N/A	N/A	AE-100654-52	N/A
5		Control Box Cover	AE-100657-51	AE-100657-51	AE-100657-51	AE-100657-51
6		Top Panel	AE-100652-52	AE-100652-52	AE-100652-53	AE-100652-53
8		Grille	95-100906-03	95-100906-03	95-100906-04	95-100906-04
		Center Cap - Blank (for Grille)	91-101123-09	91-101123-09	91-101123-09	91-101123-09
12		Valve Mounting Panel	AE-57780-01	AE-57780-01	AE-57780-01	AE-100185-51
14		Service Valve - Suction	See Coil Group			
15		Service Valve - Liquid	See Coil Group			
17		Low Voltage Cover	AE-57756-01	AE-57756-01	AE-57756-01	AE-57756-01
		Touch-up Paint - Green (Aerosol)	52-18662-48	52-18662-48	52-18662-48	52-18662-48
		Touch-up Paint - Green (Paint Pens)	523010	523010	523010	523010

No.	Notes	MODEL COOLING CAPACITY VARIATION	15PJL 42 A01	15PJL 48 A01	15PJL 60 A01	
<b>SHEET METAL PARTS, MISCELLANEOUS (Neutra Green, Before Date Code 4811)</b>						
1		Cabinet	AE-100726-54	AE-100726-54	AE-100726-54	
2		Cabinet Panel	AE-100727-54	AE-100727-54	AE-100727-54	
3		Base Pan	AE-101588-03	AE-101588-03	AE-101588-03	
4		Control Box - 2 inch diameter capacitor	AE-100654-53	AE-100654-53	N/A	
4		Control Box - 2-1/2 inch diameter capacitor	N/A	AE-100654-54	AE-100654-54	
5		Control Box Cover	AE-100657-51	AE-100657-51	AE-100657-51	
6		Top Panel	AE-100652-53	AE-100652-53	AE-100652-53	
8		Grille	95-100906-04	95-100906-04	95-100906-04	
		Center Cap - Blank (for Grille)	91-101123-09	91-101123-09	91-101123-09	
12		Valve Mounting Panel	AE-100185-51	AE-100185-51	AE-100185-51	
14		Service Valve - Suction	See Coil Group			
15		Service Valve - Liquid	See Coil Group			
17		Low Voltage Cover	AE-57756-01	AE-57756-01	AE-57756-01	
		Touch-up Paint - Green (Aerosol)	52-18662-48	52-18662-48	52-18662-48	
		Touch-up Paint - Green (Paint Pens)	523010	523010	523010	

No.	Notes	MODEL COOLING CAPACITY VARIATION	15PJL 18 A01	15PJL 24 A01	15PJL 30 A01	15PJL 36 A01
<b>ELECTRICAL/FAN GROUP</b>						
7	Stk	Fan Motor	51-101774-02	51-101774-02	51-102008-07	51-102870-01
9	Stk	Fan Blade	70-102033-02	70-102033-02	70-102011-10	70-21858-17
16	Stk	Contactora	42-42478-03	42-42478-03	42-42478-03	42-42478-03
17		Low Voltage Cover	See Panels - Miscellaneous			
18		Control Box Bottom	AE-100655-01	AE-100655-01	AE-100655-01	AE-100655-01
19		Capacitor - Compressor/Fan	See Compressor Group			
20	Stk	Defrost Control Board	47-102684-02	47-102684-02	47-102684-02	47-102684-02
21		Low Ambient Control	See Accessories Group			
		Low Pressure Control	47-103670-05	47-103670-05	47-103670-05	47-103670-05

No.	Notes	MODEL COOLING CAPACITY VARIATION	15PJL 42 A01	15PJL 48 A01	15PJL 60 A01	
<b>ELECTRICAL/FAN GROUP</b>						
7	Stk	Fan Motor - Before Date Code 1112	51-102870-03	51-102008-07	51-102728-11	
7	Stk	Fan Motor - After Date Code 1112	51-101774-13	51-102008-07	51-102728-11	
9	Stk	Fan Blade	70-21858-17	70-102011-10	70-21858-17	
16	Stk	Contactora	42-42478-03	42-42478-03	42-42478-02	
17		Low Voltage Cover	See Panels - Miscellaneous			
18		Control Box Bottom	AE-100655-01	AE-100655-01	AE-100655-01	
19		Capacitor - Compressor/Fan	See Compressor Group			
20	Stk	Defrost Control Board - Before Date Code 1112	47-102684-02	47-102685-04	47-102685-04	
20	Stk	Defrost Control Board - After Date Code 1112	47-102684-08	47-102685-04	47-102685-04	
21		Low Ambient Control	See Accessories Group			
		Low Pressure Control	47-103670-05	47-103670-05	47-103670-05	

No.	Notes	MODEL COOLING CAPACITY VARIATION	15PJL 18 A01	15PJL 24 A01	15PJL 30 A01	15PJL 36 A01
<b>COIL GROUP</b>						
11	Stk	Condenser Coil	AS-103032-03	AS-103032-03	AS-101768-03	AS-103014-03
13		Valve Mounting Bracket	AE-57781-01	AE-57781-01	AE-57781-01	AE-57781-01
14		Service Valve - Suction	61-21368-23	61-21368-23	61-21368-07	61-21368-07
15		Service Valve - Liquid	61-21368-05	61-21368-05	61-21368-05	61-21368-05
22		Bulkhead Valve	61-22369-04	61-22369-04	61-22369-04	61-22369-04
		Locknut - Bulkhead Valve	63-22368-01	63-22368-01	63-22368-01	63-22368-01
		Low Pressure Control	47-102240-04	47-102240-04	47-102240-04	47-102240-04
		Access Valve Body	61-18542-01	61-18542-01	61-18542-01	61-18542-01
		Valve Core	61-18551-01	61-18551-01	61-18551-01	61-18551-01
		Valve Cap	83-100635-01	83-100635-01	83-100635-01	83-100635-01
	Stk	Filter Drier	83-41719-04	83-41719-04	83-41719-04	83-41719-04
		Charge Compensator	N/A	N/A	N/A	83-25361-01
	Stk	TXV/Distributor Assembly	61-102437-19	61-102437-20	61-102437-21	61-102437-21
	Stk,1	Reversing Valve - See Note 1	61-102498-04	61-102498-04	61-102498-09	61-102498-09
	Stk	Solenoid Coil - Reversing Valve	61-101713-92	61-101713-92	61-101713-92	61-101713-92
		Wiring Harness - Reversing Valve	61-26149-03	61-26149-03	61-26149-03	61-26149-03
		Tube Assembly - Bulkhead Valve	AS-105377-08	AS-105377-08	N/A	AS-105377-05

No.	Notes	MODEL COOLING CAPACITY VARIATION	15PJL 42 A01	15PJL 48 A01	15PJL 60 A01	
<b>COIL GROUP</b>						
11	Stk	Condenser Coil	AS-101760-03	AS-102099-03	AS-101771-01	
13		Valve Mounting Bracket	AE-57781-02	AE-57781-02	AE-57781-02	
14		Service Valve - Suction	61-21368-22	61-21368-08	61-21368-08	
15		Service Valve - Liquid	61-21368-05	61-21368-05	61-21368-05	
22		Bulkhead Valve	61-22369-04	61-22369-04	61-22369-04	
		Locknut - Bulkhead Valve	63-22368-01	63-22368-01	63-22368-01	
	Stk	Low Pressure Control	47-102240-04	47-102240-04	47-102240-04	
	Stk	High Pressure Control (90 Deg Elbow with 5/16 inch connection) - before W0311	N/A	N/A	47-26184-02	
	Stk	High Pressure Control (90 Deg Elbow with 1/4 inch connection) - after W0311	N/A	N/A	47-103669-01	
		Access Valve Body	61-18542-01	61-18542-01	61-18542-01	
		Valve Core	61-18551-01	61-18551-01	61-18551-01	
		Valve Cap	83-100635-01	83-100635-01	83-100635-01	
	Stk	Filter Drier	83-41719-04	83-41719-04	83-41719-04	
		Charge Compensator	N/A	83-25361-05	N/A	
	Stk	TXV/Distributor Assembly	61-102437-22	61-102437-23	61-102437-24	
	Stk,1	Reversing Valve - See Note 1	61-102498-09	61-101684-06	61-102498-03	
	Stk	Solenoid Coil - Reversing Valve	61-101713-92	61-101713-92	61-101713-92	
		Wiring Harness - Reversing Valve	61-26149-03	61-26149-03	61-26149-03	
		Tube Assembly - Bulkhead Valve	AS-105377-06	AS-105377-07	AS-105377-07	

No.	Notes	MODEL COOLING CAPACITY VARIATION	15PJL 18 A01	15PJL 24 A01	15PJL 30 A01	15PJL 36 A01
<b>COMPRESSOR GROUP</b>						
		<b>Compressor ID:</b>	<b>8195</b>	<b>8196</b>	<b>8197</b>	<b>8198</b>
10	Stk	Compressor	55-102045-14S	55-102045-24S	55-102045-31S	55-102045-03S
19	Stk	Capacitor - Compressor/Fan (2 inch diameter)	43-26261-40	43-101665-09	43-26271-46	43-101666-37
19	Stk	Capacitor - Compressor/Fan (2-1/2 inch diameter)	N/A	N/A	43-101665-46	N/A
	Stk	Compressor Wiring Harness (Molded Plug)	45-100834-80	45-100834-80	45-100834-80	45-100834-80
		Crankcase Heater	N/A	N/A	N/A	N/A
		Muffler	83-26251-01	83-26251-01	83-26251-01	83-26251-01
		Charge Compensator	See Coil Group			

No.	Notes	MODEL COOLING CAPACITY VARIATION	15PJL 42 A01	15PJL 48 A01	15PJL 60 A01	
<b>COMPRESSOR GROUP</b>						
		<b>Compressor ID:</b>	<b>8199</b>	<b>8200</b>	<b>8201</b>	
10	Stk	Compressor	55-102045-15S	55-102045-06S	55-102045-58S	
19	Stk	Capacitor - Compressor/Fan (2 inch diameter, for PSC Fan Motor Units)	43-101665-52	43-26271-48	N/A	
		Capacitor - Compressor (2 inch diameter, for ECM Fan Motor Units)	43-101666-37	N/A	N/A	
19	Stk	Capacitor - Compressor/Fan (2-1/2 inch diameter, for PSC Fan Motor Units)	N/A	43-101665-48	N/A	
19	Stk	Capacitor - Compressor (2-1/2 inch diameter, for ECM Fan Motor Units)	N/A	N/A	43-100510-29	
	Stk	Compressor Wiring Harness (Molded Plug)	45-100834-80	45-100834-80	45-100834-80	
		Crankcase Heater	N/A	44-103663-01	44-103663-01	
		Muffler	83-26251-01	83-26251-01	83-26251-01	
		Charge Compensator	See Coil Group			



No.	Notes	MODEL COOLING CAPACITY VARIATION	15PJL ALL ALL
<b>ACCESSORIES</b>			
		Low Ambient Control	RXAD-A08
		Outdoor Thermostat (One Thermostat w/box)	RXPT-A01
		Outdoor Thermostat (One Thermostat w/o box)	RXPT-A02
		Outdoor Thermostat (One w/Heat Relay and box)	RXPT-A03
		Outdoor Thermostat (Two Thermostats w/Heat and box)	RXPT-A04
		Heat Pump Monitor	RXPM-B01
		Compressor Time Delay Control	RXMD-B01
		Blower Time Delay Control	RXMD-C04
		High Pressure Control	RXAB-A07

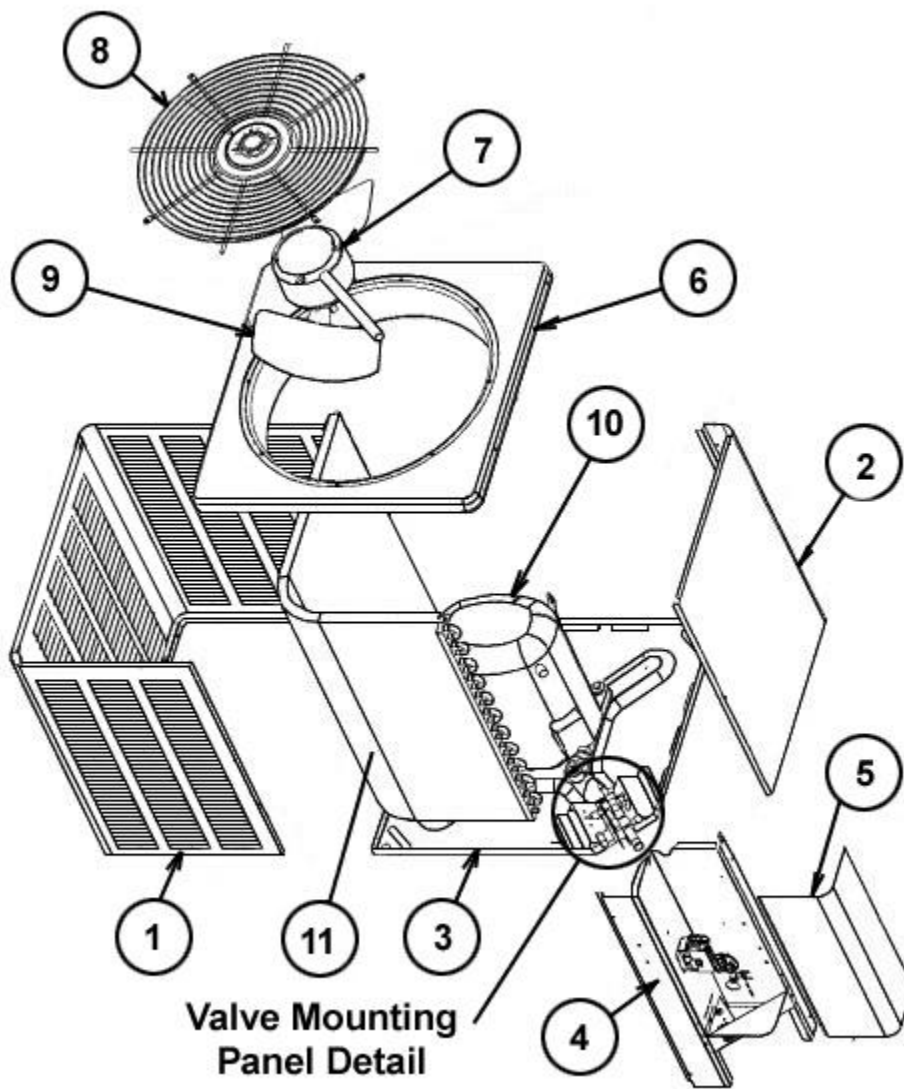

**Valve Mounting  
Panel Detail**

Exploded View

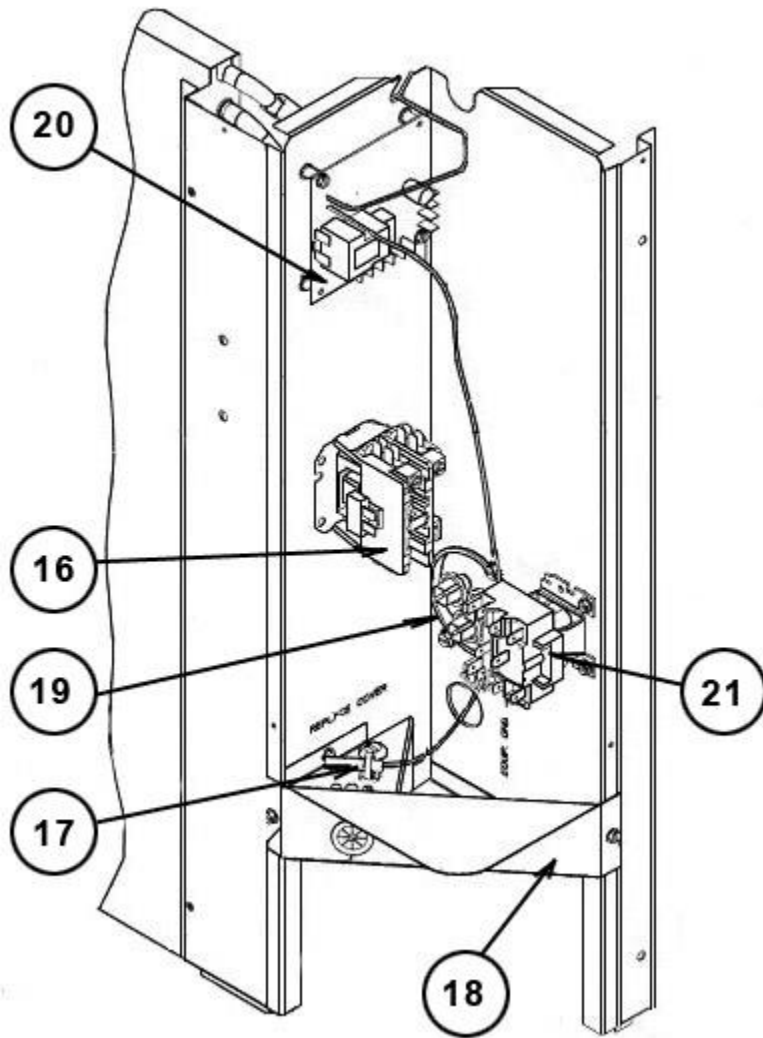

Control Box Assembly

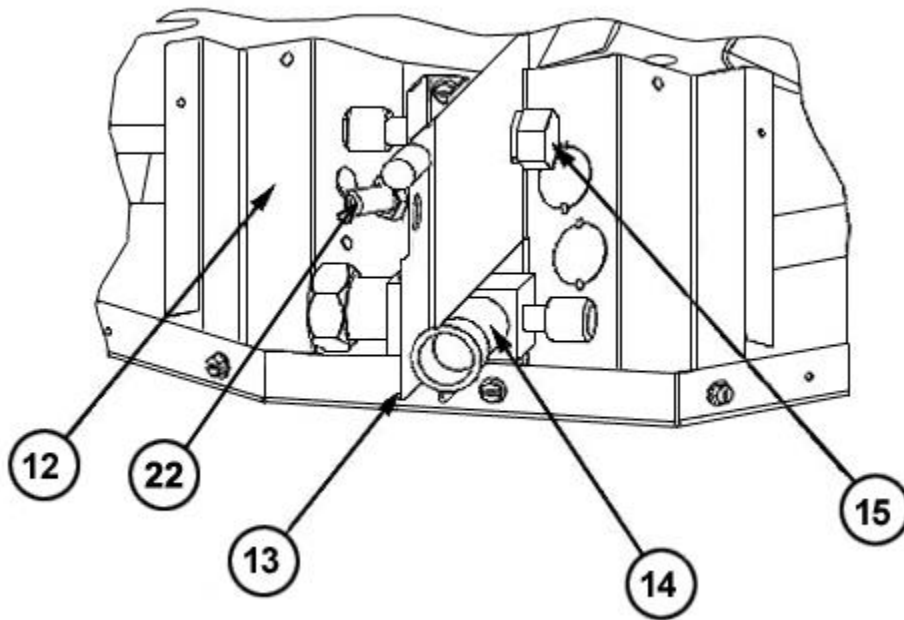

Valve Mounting Detail

# NOTES

Stk It is recommended that stock be maintained for this part.

N/A Not Applicable

- 1 The reversing valve specified for 030, 036, 042 models may be different than the one originally supplied with the equipment. The use of the specified valve is recommended for improved shifting performance.

**DISCLAIMER:** This document is intended to provide general replacement parts information to aid qualified service personnel in the repair of these models. The complete Model and Serial Number of the unit under repair should be specified when selecting and ordering replacement parts. Specifications and illustrations are subject to change without notice. Document 92-42805-15PJL supersedes all previous parts lists for these models. See <http://www.rheempartslists.net/92-42805-15PJL> for the latest revision of this document. The manufacturer assumes no obligation for errors or omissions. Service personnel must verify the proper and safe operation of equipment after the replacement of any original components.