



OIL FIRED FURNACE INSTALLATION AND OPERATION MANUAL WITH USERS INFORMATION SECTION

HIGHBOY MODELS:
VH8FA119P60B, VH8FA119T60B

LOWBOY MODELS:
VL8FA119P60B, VL8RA119P60B

⚠ WARNING: IF THE INFORMATION IN THESE INSTRUCTIONS IS NOT FOLLOWED EXACTLY, A FIRE OR EXPLOSION MAY RESULT CAUSING PROPERTY DAMAGE, PERSONAL INJURY, OR LOSS OF LIFE.

DO NOT STORE OR USE GASOLINE OR OTHER FLAMMABLE VAPORS AND LIQUIDS IN THE VICINITY OF THIS OR ANY OTHER APPLIANCE.

⚠ WARNING: IMPROPER INSTALLATION, ADJUSTMENT, ALTERATION, SERVICE, OR MAINTENANCE CAN CAUSE INJURY OR PROPERTY DAMAGE. REFER TO THIS MANUAL. FOR ASSISTANCE OR ADDITIONAL INFORMATION CONSULT A QUALIFIED INSTALLER, OR SERVICE AGENCY.

⚠ AVERTISSEMENT: SI L'INFORMATION DANS CES INSTRUCTIONS N'EST PAS SUIVI À LA LETTRE, UN INCENDIE OU UNE EXPLOSION ENTRAÎNANT DES DOMMAGES MATÉRIELS, DES BLESSURES CORPORELLES OU DES PERTES DE VIE.

NE PAS ENTREPOSER NI UTILISER D'ESSENCE OU AUTRES VAPEURS ET LIQUIDES INFLAMMABLES À PROXIMITÉ DE CET APPAREIL OU DE TOUT AUTRE APPAREIL.

⚠ AVERTISSEMENT: UNE MAUVAISE INSTALLATION, D'AJUSTEMENT, DE LA MODIFICATION, D'ENTRETIEN OU DE MAINTENANCE PEUVENT CAUSER DES BLESSURES OU DOMMAGES MATÉRIELS, REPORTEZ-VOUS À CE MANUEL POUR OBTENIR DE L'AIDE OU DES RENSEIGNEMENTS SUPPLÉMENTAIRES, CONSULTER UN INSTALLATEUR QUALIFIÉ, OU ORGANISME DE SERVICE.

PLEASE READ THESE INSTRUCTIONS PRIOR TO INSTALLATION, INITIAL FIRING, AND BEFORE PERFORMING ANY SERVICE OR MAINTENANCE. THESE INSTRUCTIONS MUST BE LEFT WITH THE USER AND SHOULD BE RETAINED FOR FUTURE REFERENCE BY QUALIFIED SERVICE PERSONNEL.

VEUILLEZ LIRE CES INSTRUCTIONS AVANT L'INSTALLATION, LES PREMIERS TIRS, ET AVANT D'EFFECTUER TOUT ENTRETIEN OU MAINTENANCE. CES INSTRUCTIONS DOIVENT ÊTRE LAISSÉS AVEC L'UTILISATEUR ET DEVAIT ÊTRE CONSERVÉ POUR RÉFÉRENCE FUTURE PAR UN TECHNICIEN QUALIFIÉ.



Manufactured by:
Thermo Products, LLC
5235 West State Road 10
North Judson, Indiana 46366



MO-514
ECN 5486-MA 170821

CONTENTS

<u>SECTION</u>	<u>PAGE</u>
I. SAFETY SECTION.....	1
A. CODES AND CLEARANCES.....	4
B. MAKE-UP AIR.....	6
II. GENERAL INSTRUCTIONS.....	7
A. CHIMNEY.....	8
B. VENTING.....	12
C. DRAFT REGULATORS.....	13
D. DUCT WORK/AIR CONDITIONING.....	13
E. AIR FILTER(S).....	14
F. LIMIT POSITION AND LOCATION.....	16
G. BURNER INSTALLATION.....	16
H. BURNER SPECIFICATIONS AND APPLICATIONS.....	17
I. OILTANK AND PIPING.....	18
J. FILTER.....	18
K. ELECTRICAL WIRIING.....	18
L. BLOWER MOTOR SPEED SELECTION.....	20
M. BLOWER CONTROLLER INFORMATION FOR PSC AND CTM MOTOR.....	25
N. STARTUP PROCEDURES.....	30
III. USERS INFORMATION SECTION.....	32
A. OIL SUPPLY.....	32
B. COMBUSTION AIR SUPPLY.....	32
C. INSPECTION AREAS.....	32
D. STARTING THE BURNER.....	33
E. FILTER CLEANING AND LOCATION.....	33
IV. DEALER MAINTENANCE.....	34
A. HEAT EXCHANGER CLEANING INSTRUCTIONS.....	34
V. SEQUENCE OF OPERATIONS FLOW CHART.....	36
IX. TROUBLE SHOOTING FLOW CHART.....	38
APPENDIX – A REPLACEMENT PARTS LIST.....	44
APPENDIX – B WIRING DIAGRAMS.....	48

I. SAFETY SECTION

This page and the following contain various warnings and cautions found throughout the Oil Furnace Manual. Please read and comply with the statements below.

WARNING AND CAUTIONS:

WARNING: This furnace is not to be used as a construction heater. **See Page 4**

WARNING: The predetermined limit locations on all of the Spirit oil-fired furnaces have been tested and approved. Any attempt to relocate these safety controls or replace these safety controls with a control that is not approved, or is incompatible, may result in personal injury, substantial property damage or death. **See Page 15**

WARNING: THE HEAT EXCHANGER MUST BE CLEANED BY A QUALIFIED SERVICE PERSON. **See Page 34**

CAUTION: DO NOT ATTEMPT TO MAKE REPAIRS YOURSELF! **See Page 32**

WARNING: The area around the furnace should be kept free and clear of combustible liquids and material, especially papers and rags. **See Page 32**

WARNING: NEVER burn garbage or refuse in your furnace. Never try to ignite oil by tossing burning papers or other material into your furnace. **See Page 32**

WARNING: Spirit oil furnaces are designed to burn No. 1 or No. 2 distillate fuel oil. Bio fuel blend up to 5% (B5) is permissible. **NEVER USE GASOLINE OR A MIXTURE OF OIL AND GASOLINE.** **See Page 32**

CAUTION: DO NOT ATTEMPT TO START THE BURNER WHEN:

1. Excess oil has accumulated,
2. The furnace is full of vapors
3. The combustion chamber is very hot.

IF ONE OR MORE OF THESE CONDITIONS EXIST, CONTACT A QUALIFIED SERVICE PERSON. See Page 32

WARNING: DO NOT START BURNER UNLESS BLOWER DOOR IS SECURED IN PLACE.

⚠ CAUTION

ROTATING FAN BLADE!

To avoid injury from hot or moving parts, shut off the furnace and allow to cool before removing this door.

When it becomes necessary to replace or wash filter, remove the dirty filter from the racks provided and wash or replace with identical new filters.

The blower motor located behind this door may or may not require lubrication. If lubrication instructions are not shown on the motor nameplate, the motor should not be lubricated. If the nameplate indicates that the motor requires lubrication, lubricate the motor as directed or use 30 drops of SAE 20 weight oil or equivalent twice a year. Do not use a light household grade oil.

⚠ ATTENTION

PALE DE VENTILATEUR EN ROTATION!

Pour éviter d'être blessé par des pièces chaudes ou en rotation, arrêter la fournaise et attendre qu'elle refroidisse avant de retirer cette porte.

Quand il devient nécessaire de remplacer ou de laver le filtre, retirer le filtre sale des supports prévus et le laver ou le remplacer par un filtre neuf identique.

Le moteur de soufflerie situé derrière cette porte peut ou non avoir besoin de lubrification. S'il n'y a pas d'instructions de lubrification sur la plaque signalétique du moteur, celui-ci ne doit pas être lubrifié. Si la plaque signalétique indique que le moteur a besoin d'être lubrifié, le lubrifier comme indiqué ou utiliser 30 gouttes d'huile SAE 20 ou équivalente deux fois par an. Ne pas utiliser d'huile domestique légère.

⚠ WARNING

REINSTALL ALL PARTS!

Should this unit be disassembled all components, panels, block offs, collars, gaskets, and fasteners must be reassembled as originally factory produced.

Failure to do so may result in property damage, injury, or loss of life.

⚠ AVERTISSEMENT

REMONTER TOUTES LES PIÈCES!

En cas de démontage de cet appareil, tous les composants, panneaux, obturations, colliers, joints et fixations doivent être remontés comme à l'origine.

⚠ CAUTION

RESEAL HEAT EXCHANGER ACCESS PORTS

Clean outs accessible by qualified service personnel only. Access to clean out may require removal of panel. Be certain clean out covers and/or gaskets are intact and in proper position to ensure complete seal prior to operation.

Failure to do so may result in property or equipment damage.

⚠ ATTENTION

REBOUCHER LES ORIFICES D'ACCÈS À L'ÉCHANGEUR DE CHALEUR

Regards de visite accessibles uniquement au personnel d'entretien qualifié. L'accès aux regards de visite peut nécessiter la dépose du panneau. Vérifier que les couvercles et/ou joints des regards de visite sont en bon état et bien en place pour assurer l'étanchéité avant d'utiliser la fournaise.

Le non-respect de cette consigne peut provoquer des dommages matériels ou la détérioration de l'équipement.

⚠ WARNING

ANNUAL SERVICE REQUIRED

The following items should be inspected every year by a qualified heating servicer. (Shut off power before inspecting.) Correct any deficiencies at once. Failure to do so may result in injury, property damage or loss of life.

Chimney/Vent Pipe: Inspect for restriction, loose joints, abnormal carbon build up and condensation.

Controls: Check for correct operation and proper settings, (if manually adjustable).

Periodic visual inspections should also be made by the owner during the heating season. Call a qualified heating servicer to report suspected deficiencies. (Do not attempt to make repairs yourself!)

Further owner and heating servicer responsibilities are detailed in the printed information provided with the furnace.

Heat Exchanger: Inspect for corrosion, pitting, warpage, cracks, deterioration, carbon build up and loose gaskets.

Burner: Check for correct operation, proper combustion, no fuel leakage, and replace burner oil filter.

⚠ AVERTISSEMENT

ENTRETIEN ANNUEL NÉCESSAIRE

Les composants suivants doivent être inspectés chaque année par un technicien en chauffage qualifié. (Couper l'alimentation électrique avant l'inspection.) Corriger immédiatement tous les défauts. Le non-respect de cette consigne pourrait causer des dommages matériels, des blessures ou même la mort.

Échangeur de chaleur: Vérifier la présence de corrosion, piqûres, fissures, détérioration, calamine et joints dégradés.

Brûleur: Vérifier le fonctionnement correct, la combustion, l'absence de fuite de combustible et remplacer le filtre à mazout du brûleur.

Cheminée/tuyau d'évacuation: Vérifier la présence de restrictions, joints dégradés, accumulation anormale de calamine et condensation.

Commandes: Vérifier le fonctionnement et les réglages (s'ils sont manuels).

Le propriétaire devra également effectuer des inspections visuelles périodiques pendant la saison de chauffage. Appelez un technicien qualifié en chauffage pour l'informer de défauts éventuels. (N'essayez pas de réparer vous-même!!)

Les autres responsabilités du propriétaire et du technicien en chauffage sont détaillées dans les renseignements imprimés fournis avec la fournaise.

⚠ WARNING

HAZARDOUS VOLTAGE

Avoid contact with exposed live voltage terminals. Do not bypass or disconnect limit. Turn off power prior to service.

Failure to do so may result in property damage, injury, or loss of life.

⚠ AVERTISSEMENT

TENSIONS DANGEREUSES

Éviter le contact avec les terminaux de tension états exposés. Ne pas contourner ou se déconnecter de limite. Coupez courant avant de service.

Omission de le faire peut entraîner perte de vie, des blessures ou des dommages à la propriété.

CONNECT ELECTRICAL POWER (120V/60Hz/1PH) TO WIRES INSIDE THE JUNCTION BOX.

- "HOT" LINE TO WIRE #1
- "COMMON" LINE TO WIRE #2
- "GROUND" LINE TO GROUNDING SCREW

⚠ WARNING

This compartment must be closed except when servicing.

⚠ AVERTISSEMENT

Ce compartiment doit être fermé sauf pendant l'entretien.

KEEP CLOSED WHEN APPLIANCE IS IN OPERATION

DOIT ÊTRE FERMÉ QUAND L'APPAREIL FONCTIONNE

⚠ WARNING

PROFESSIONAL INSTALLATION AND SERVICE REQUIRED!

This unit must be installed and serviced by a qualified servicer. Failure to do so may result in property damage, injury, or loss of life.

⚠ AVERTISSEMENT

INSTALLATION ET RÉPARATION PAR DES PROFESSIONNELS UNIQUEMENT!

Cet appareil doit être installé et réparé par un technicien d'entretien qualifié. Le non-respect de cette consigne pourrait causer des dommages matériels, des blessures ou même la mort.

⚠ CAUTION

USE COPPER CONDUCTORS ONLY!

Unit terminals are not designed to accept other types of conductors. Failure to do so may cause damage to the equipment.

⚠ ATTENTION

UTILISEZ UNIQUEMENT DES CONDUCTEURS EN CUIVRE!

Les bornes de l'unité ne sont pas conçues pour accepter d'autres types de conducteurs. Le non-respect de cette consigne pourrait entraîner des dommages matériels.

 CONTROL NO. 2000980
Intertek
 MODEL NO. SERIAL NO.



OIL FIRED FURNACE
 CONFORMS TO UL STD 727 CERTIFIED TO CAN/CSA STD B140.4
 FOR USE ONLY WITH R.W. BECKETT OIL BURNER MODEL AFG
 USE NO. 2 (DISTILLATE) FUEL OIL.

IDENTIFIER	INPUT BTU/HR	OUTPUT BTU/HR	-B BECKETT AFG NOZ GPH/TYP
-100	119,000	101,000	0.85 80° A
-119+	140,000	119,000	1.00 80° A
-132	156,250	132,000	1.10 80° A

PUMP PRESSURE 120 PSI

+ FACTORY EQUIPPED NOZZLE. MAX INPUT 1.10 GPH
 FOR GREATEST EFFICIENCY (AFUE) SET THE BURNER COMBUSTION FOR 12% CO2 MAXIMUM WITH NO GREATER THAN A TRACE POINT OF SMOKE AND FURNACE TEMPERATURE RISE FOR 66° F MAXIMUM.

ELECTRICAL SPECIFICATIONS 120 VOLTS 60 HZ 1 PHASE
 TOTAL CURRENT (AMPS) 18
 MINIMUM CIRCUIT AMPACITY 19.2
 MAXIMUM FUSE SIZE (AMPS) 20

THERMO PRODUCTS, LLC.
 P.O. BOX 217 NORTH JUDSON, IN 46366

3004215 (1) 5206 BA
1099-V25415-BA

 CONTROL NO. 2000980
Intertek
 MODEL NO. SERIAL NO.



OIL FIRED FURNACE
 CONFORMS TO UL STD 727 CERTIFIED TO CAN/CSA STD B140.4
 FOR USE ONLY WITH R.W. BECKETT OIL BURNER MODEL AFG
 USE NO. 2 (DISTILLATE) FUEL OIL.

IDENTIFIER	INPUT BTU/HR	OUTPUT BTU/HR	-B BECKETT AFG NOZ GPH/TYP
-100	119,000	101,000	0.85 80° A
-119+	140,000	119,000	1.00 80° A
-132	156,250	132,000	1.10 80° A

PUMP PRESSURE 120 PSI

+ FACTORY EQUIPPED NOZZLE. MAX INPUT 1.10 GPH
 FOR GREATEST EFFICIENCY (AFUE) SET THE BURNER COMBUSTION FOR 12% CO2 MAXIMUM WITH NO GREATER THAN A TRACE POINT OF SMOKE AND FURNACE TEMPERATURE RISE FOR 66° F MAXIMUM.

ELECTRICAL SPECIFICATIONS 120 VOLTS 60 HZ 1 PHASE
 TOTAL CURRENT (AMPS) 14.6
 MINIMUM CIRCUIT AMPACITY 17.5
 MAXIMUM FUSE SIZE (AMPS) 20

THERMO PRODUCTS, LLC.
 P.O. BOX 217 NORTH JUDSON, IN 46366

3004215 (1) 5206 BA
1099-V25415-BA

DIRECT DRIVE BLOWER
 EXTERNAL STATIC PRESSURE (INCHES W.C.) 0.20 TO 0.50
 MAXIMUM DESIGNED OUTLET AIR TEMPERATURE 180°F OR LESS

FOR INSTALLATION IN A CLOSET OR ALCOVE ON COMBUSTIBLE FLOORING WITH CLEARANCES TO UNPROTECTED COMBUSTIBLE MATERIAL NOT LESS THAN:

ANY SIDE OF SUPPLY/PLENUM (INCHES)	TOP	SIDES	REAR	FRONT	FLUE PIPE
1	1	0	0	6*	8

* 24 INCHES FOR SERVICE PURPOSES

CLOSET INSTALLATION REQUIRES TWO SEPARATE VENTILATION OPENINGS LOCATED 6 INCHES FROM THE TOP AND BOTTOM OF THE CLOSET DOORS OR PANELS MEASURING NOT LESS THAN 19 INCHES WIDE BY 9-1/2 INCHES HIGH.

3004215 (1) 5206 BA
1099-V25415-BA

DIRECT DRIVE BLOWER
 EXTERNAL STATIC PRESSURE (INCHES W.C.) 0.20 TO 0.50
 MAXIMUM DESIGNED OUTLET AIR TEMPERATURE 180°F OR LESS

FOR INSTALLATION IN A CLOSET OR ALCOVE ON COMBUSTIBLE FLOORING WITH CLEARANCES TO UNPROTECTED COMBUSTIBLE MATERIAL NOT LESS THAN:

ANY SIDE OF SUPPLY/PLENUM (INCHES)	TOP	SIDES	REAR	FRONT	FLUE PIPE
1	1	0	0	6*	8

* 24 INCHES FOR SERVICE PURPOSES

CLOSET INSTALLATION REQUIRES TWO SEPARATE VENTILATION OPENINGS LOCATED 6 INCHES FROM THE TOP AND BOTTOM OF THE CLOSET DOORS OR PANELS MEASURING NOT LESS THAN 19 INCHES WIDE BY 9-1/2 INCHES HIGH.

3004215 (1) 5206 BA
1099-V25415-BA

 CONTROL NO. 2000980
Intertek
 MODEL NO. SERIAL NO.



OIL FIRED FURNACE
 CONFORMS TO UL STD 727 CERTIFIED TO CAN/CSA STD B140.4
 FOR USE ONLY WITH R.W. BECKETT OIL BURNER MODEL AFG
 USE NO. 2 (DISTILLATE) FUEL OIL.

IDENTIFIER	INPUT BTU/HR	OUTPUT BTU/HR	-B BECKETT AFG NOZ GPH/TYP
-100	119,000	101,000	0.85 80° A
-119+	140,000	119,000	1.00 80° A
-132	156,250	132,000	1.10 80° A

PUMP PRESSURE 120 PSI

+ FACTORY EQUIPPED NOZZLE. MAX INPUT 1.10 GPH
 FOR GREATEST EFFICIENCY (AFUE) SET THE BURNER COMBUSTION FOR 12% CO2 MAXIMUM WITH NO GREATER THAN A TRACE POINT OF SMOKE AND FURNACE TEMPERATURE RISE FOR 66° F MAXIMUM.

ELECTRICAL SPECIFICATIONS 120 VOLTS 60 HZ 1 PHASE
 TOTAL CURRENT (AMPS) 15.3
 MINIMUM CIRCUIT AMPACITY 18.4
 MAXIMUM FUSE SIZE (AMPS) 20

THERMO PRODUCTS, LLC.
 P.O. BOX 217 NORTH JUDSON, IN 46366

3004215 (1) 5206 BA
1099-V25415-BA

 CONTROL NO. 2000980
Intertek
 MODEL NO. SERIAL NO.



OIL FIRED FURNACE
 CONFORMS TO UL STD 727 CERTIFIED TO CAN/CSA STD B140.4
 FOR USE ONLY WITH R.W. BECKETT OIL BURNER MODEL AFG
 USE NO. 2 (DISTILLATE) FUEL OIL.

IDENTIFIER	INPUT BTU/HR	OUTPUT BTU/HR	-B BECKETT AFG NOZ GPH/TYP
-100	119,000	101,000	0.85 80° A
-119+	140,000	119,000	1.00 80° A
-132	156,250	132,000	1.10 80° A

PUMP PRESSURE 120 PSI

+ FACTORY EQUIPPED NOZZLE. MAX INPUT 1.10 GPH
 FOR GREATEST EFFICIENCY (AFUE) SET THE BURNER COMBUSTION FOR 12% CO2 MAXIMUM WITH NO GREATER THAN A TRACE POINT OF SMOKE AND FURNACE TEMPERATURE RISE FOR 66° F MAXIMUM.

ELECTRICAL SPECIFICATIONS 120 VOLTS 60 HZ 1 PHASE
 TOTAL CURRENT (AMPS) 15.6
 MINIMUM CIRCUIT AMPACITY 18.7
 MAXIMUM FUSE SIZE (AMPS) 20

THERMO PRODUCTS, LLC.
 P.O. BOX 217 NORTH JUDSON, IN 46366

3004215 (1) 5206 BA
1099-V25415-BA

DIRECT DRIVE BLOWER
 EXTERNAL STATIC PRESSURE (INCHES W.C.) 0.20 TO 0.50
 MAXIMUM DESIGNED OUTLET AIR TEMPERATURE 180°F OR LESS

FOR INSTALLATION IN A CLOSET OR ALCOVE ON NON-COMBUSTIBLE FLOORING WITH CLEARANCES TO UNPROTECTED COMBUSTIBLE MATERIAL NOT LESS THAN:

ANY SIDE OF SUPPLY/PLENUM (INCHES)	TOP	SIDES	REAR	FRONT	FLUE PIPE
1	1	0	0*	6*	8

* 24 INCHES FOR SERVICE PURPOSES

CLOSET INSTALLATION REQUIRES TWO SEPARATE VENTILATION OPENINGS LOCATED 6 INCHES FROM THE TOP AND BOTTOM OF THE CLOSET DOORS OR PANELS MEASURING NOT LESS THAN 19 INCHES WIDE BY 9-1/2 INCHES HIGH.

3004215 (1) 5206 BA
1099-V25415-BA

DIRECT DRIVE BLOWER
 EXTERNAL STATIC PRESSURE (INCHES W.C.) 0.20 TO 0.50
 MAXIMUM DESIGNED OUTLET AIR TEMPERATURE 180°F OR LESS

FOR INSTALLATION IN A CLOSET OR ALCOVE ON NON-COMBUSTIBLE FLOORING WITH CLEARANCES TO UNPROTECTED COMBUSTIBLE MATERIAL NOT LESS THAN:

ANY SIDE OF SUPPLY/PLENUM (INCHES)	TOP	SIDES	REAR	FRONT	FLUE PIPE
1	1	0	0*	6*	8

* 24 INCHES FOR SERVICE PURPOSES

CLOSET INSTALLATION REQUIRES TWO SEPARATE VENTILATION OPENINGS LOCATED 6 INCHES FROM THE TOP AND BOTTOM OF THE CLOSET DOORS OR PANELS MEASURING NOT LESS THAN 19 INCHES WIDE BY 9-1/2 INCHES HIGH.

3004215 (1) 5206 BA
1099-V25415-BA

The entire text of these instructions must be read and understood, before installing the appliance. It is the installer's responsibility to do the following:

1. Inform and demonstrate to the user, the correct operation and maintenance of the appliance, as explained in the **Homeowner/User Information and Routine Maintenance** section of this manual.
2. Inform the user of the hazards of flammable liquids and vapors and to remove such liquids and vapors from the vicinity of the appliance.
3. Inform the user of all pertinent warnings and precautions concerning this appliance.
4. It is recommended that a commercially available CO alarm be installed in conjunction with any fossil fuel burning appliance. The CO alarm shall be installed according to the alarm manufacturer's installation instructions and be listed in accordance with latest edition of the UL Standard for Single and Multiple Station Carbon Monoxide Alarms, UL 2034, or the CSA International Standard, Residential Carbon Monoxide Alarming Devices, CSA 6.19.

WARNING: This unit is not to be used for temporary heating of buildings, or structures, under construction. Construction dust may enter the appliance or the duct system and cause a fire hazard. Certain chemicals used during construction when burned, form corrosive condensate that can substantially reduce the life of the heating system heat exchanger.

This appliance is shipped completely assembled and internally wired. All electrical wiring has been factory installed and inspected. At the time of installation, the unit will require connection to electric power, fuel oil supply, and supply and return air ductwork.

This unit uses a fan-assisted combustion system, consisting of a pressure atomizing, oil burner and combustion air blower, used to push the products of combustion through the heat exchanger system. After installation, the furnace and duct system must be adjusted to obtain a temperature rise of 51°F to 81°F through the unit. (Refer to the rating label located on side panel inside the burner compartment). The return air temperature must be above 55°F to prevent condensation of flue products in the heat exchanger. The installation must conform with local codes or, in the absence of local codes, with the Standard for the Installation of Oil-Burning Equipment, NFPA 31-1997, or the latest edition, and to these instructions. The installation must also comply with CSA B139 for recommended installation practices where applicable.

A. CODES AND CLEARANCES:

The following items must be considered when choosing the size and location of the unit.

1. **All local codes and/or regulations take precedence over the instructions in this manual and should be followed accordingly.** In the absence of local codes, installation must conform to these instructions and the guidelines of the National Fire Protection Association (NFPA). Two applicable NFPA installation codes are the National Electrical Code, ANSI/NFPA 70-1999, and Standard for the Installation of Oil-Burning Equipment, NFPA 31-1997. The latest editions of these codes should be consulted.
2. The selection of a heating unit should be based on a rate of heat loss calculation for the residence according to the manuals provided by the Air Conditioning Contractors of America (ACCA) or the American Society of Heating, Refrigeration, and Air Conditioning Engineers (ASHRAE). The heating capacity of the unit proposed for installation should meet or slightly exceed the rate of heat loss for the residence. Over sizing should not exceed 25% of the heat loss calculation.
3. When installed, this unit should be level. If possible, it should be installed in a central location, with respect to outlet registers of the supply air ductwork.

4. Definitions of "combustible" and "non-combustible" materials as presented in the 1996 version of the National Fuel Gas Code, ANSI Z223.1-1996/NFPA 70-1996, are as follows:

a. **Combustible material:**

"...materials made of or surfaced with wood, compressed paper, plant fibers, or other materials that are capable of being ignited and burned. Such materials shall be considered combustible even though flame proofed, fire-retardant treated, or plastered."

b. **Non-combustible material:**

"...material that is not capable of being ignited and burned; such as material consisting entirely of, or a combination of, steel, iron, brick, concrete, slate, asbestos, glass, and plaster."

⚠WARNING: Carefully read and thoroughly understand the following guidelines and warnings before continuing with the installation of this appliance. Failure to follow these guidelines can cause improper and unsafe operation of this appliance. Unsafe operation can result in substantial property damage, severe personal injury, or death.

1. This appliance shall be used with only the type of fuel oil for which it is approved. Refer to the appliance-rating label for the required type of fuel.
2. This appliance is an oil-fired furnace designed for installation on non-combustible materials. This appliance is also approved for attic installation on non-combustible materials.
3. Ensure that adequate combustion and ventilation air is available to the unit.
4. The airflow resistance of the duct system attached to this appliance must fall within the allowable external static pressure range for this unit. Refer to the **Airflow Requirements and Sizing of Ductwork** section of this manual.
5. Make sure supply and return air ducts are completely sealed to the appliance casing. Refer to the **Airflow Requirements and Sizing of Ductwork** section of this manual.

NOTE: Both the VH8FA119* and VL8F/R* furnaces are approved for closet installation. The VH8FA119* and VL8F/R* require two openings in the closet door, each having a minimum area of 181 sq. inches. This free area intentionally exceeds the recommended minimum free area of 1 square inch per 1000 BTUH of input rate.

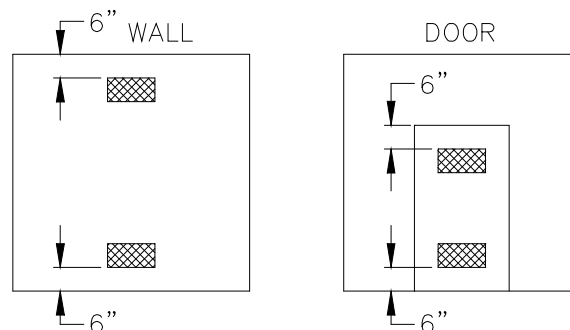

Fig 1: Properly Positioned Combustion Air Openings In Walls (Fig. 1A) and Doors (Fig. 1B).

B. MAKE-UP AIR: Today's emphasis on home insulation increases the probability of inadequate air supply to the furnace. Heavy insulation cuts off infiltration of outside air, which previously replaced inside air removed by bathroom, kitchen and laundry vent fans, and air escaping up chimneys. This causes a negative pressure differential within the home that reduces the supply of air available to the furnace for combustion and ventilation.

The Spirit Make-Up-Air Control, installs quickly and easily on any warm air heating system, delivers controlled, fresh air automatically during the winter and a constant supply of clean, fresh air for comfortable summer living. It resolves the negative pressure differential problem.

II. GENERAL INSTRUCTIONS - READ BEFORE START OF INSTALLATION

1. The heating output capacity of the furnace proposed for installation should be based on a heat loss calculation made according to the manuals provided by the Air Conditioning Contractors of America (ACCA) or the American Society of Heating, Refrigeration and Air Conditioning Engineers, Inc. (ASHRAE).
2. All local codes and/or regulations take precedence over the instructions in this manual and should be followed accordingly. In the absence of local codes, installation must conform with these instructions and regulations of the National Fire Protection Association, and to the provisions of the National Electrical Code (ANSI/NFPA 70-1999 or latest edition).
3. The installed furnace must be level and positioned in a central location with respect to outlet registers. It should be located near the chimney to minimize any horizontal run of flue pipe, which may be required.
4. A furnace installed in a residential garage must be installed so the burner and ignition source are located higher than 18 inches above the floor. The furnace must also be located or protected to avoid physical damage by vehicles.

WARNING: This furnace is not to be used as a construction heater.

5. Listed below are definitions of "COMBUSTIBLE MATERIAL" and "NON-COMBUSTIBLE MATERIAL."

Combustible Material: is made of or surfaced with wood, compressed paper, plant fibers, plastics, or other material that will ignite and burn, whether flame resistant or not.

Non-Combustible Material: is material that is not capable of being ignited and burned. Such materials consist entirely of, or a combination of, steel, iron, brick, tile, concrete, slate, or glass.

Table 1: MINIMUM CLEARANCES TO COMBUSTIBLE MATERIALS

TYPE OF UNIT	MODEL NO.	FROM SIDES OF FURNACE	FRONT ³	TOP & SIDES OF PLENUM	FROM THE FLUE/VENT	REAR
Highboy	VH8FA119*	0"	8" Note ¹	1"	8"	0"
Lowboy	VL8*	0"	6" Note ²	1"	8"	0" Note ³

Note: ¹ VH8FA119* front clearance: 8" for Closet, 24" for Alcove.

² VL8* front clearance: 6" for Closet, 24" for Alcove.

³ The minimum clearances are for fire protection. Clearance for servicing the furnace should be at least 24 inches.

A. CHIMNEY:

The furnace must be connected to an adequate chimney or an approved vent in accordance with these instructions. An adequate chimney is one that is sealed and lined with the capability of producing a (-).04" WC flue draft and having the capacity to handle the amount of stack gases that are introduced into it. A chimney with an internal construction of corrosion resistant tile, stainless steel, or some other material that will withstand flue gas temperatures up to 900°F is required.

Qualified service personnel must perform all installations and services.

The following are common chimney requirements necessary for the furnace to operate correctly:

A masonry chimney serving a Spirit oil fired furnace must comply with local codes and NFPA Standard for Chimneys, Fireplaces, Vents, and Solid Fuel Burning Appliances (NFPA211-1996 or latest edition).

1. PREVENTION OF CHIMNEY CONDENSING:

Stack gas may do one of two things as it escapes up the chimney:

- A. Remain entirely in a gaseous state if the internal chimney wall temperature is above the dew point
- B. Condense water vapor on the chimney walls if they are chilled below the dew point.

Condensing will always occur on chimney walls whose temperatures are below the dew point, but the condensate may evaporate when the walls warm above the dew point. If the chimney wall temperature does not exceed the dew point during the heating cycle of the furnace, the moisture may accumulate in large enough quantities to cause problems such as corrosion of a metal chimney (especially plain steel or galvanized steel), erosion and break up of a tile liner in a masonry chimney and, in severe cases, corrosion of the heat exchanger. Condensate also could enter the home through cracks or joints in the chimney in a worse case situation.

Condensation most likely will not occur at the bottom of the chimney because the stack gas heats the chimney walls as it rises and the bottom will be heated first. This heating of the walls will cause the stack gas temperature to drop, which in turn may reduce the stack gas temperature below dew point, causing condensation to appear on the upper part of the chimney first. This condensation may then run down inside the chimney and drip back as far as the flue pipe and heat exchanger, where corrosion may occur, if not treated.

To prevent condensation, it is necessary that the internal chimney wall temperature always be kept above the dew point. If the chimney is a masonry type, it may have to be fitted with a flue liner, when the temperature loss is too great for the furnace. If the chimney is a metal type, then an "all fuel" chimney must be used, such as a Class "A" triple wall or insulated metal chimney. A liner will act as an insulator and reduce the stack gas temperature loss. Insulation may be added around the liner for further temperature stability. If the chimney is on the home's exterior or passes through a sizable, unheated area of the building, such as a porch, high ceiling attic, etc., and condensing occurs, the chimney must be insulated around its exterior to help the flue hold its temperature. Also, check to see if the chimney is too large for the furnace and other appliances connected to it. If so, reduce to proper size (see Appendix E of NFPA31) by lining. Be sure to use stainless steel liners, such as stainless types 430, 304, or for the toughest corrosion problems, type 316. If the chimney is the correct size for the unit and condensing still occurs, then insulating the vent connector and/or reducing the efficiency of the furnace may have to be done to raise the chimney temperature.

More detailed information may be obtained from the latest edition of the ASHRAE HVAC Systems and Equipment Handbook.

2. PROPER CHIMNEY HEIGHT:

The chimney shall terminate at least 3 feet above the highest point where it passes through the roof of a building and at least 2 feet higher than any portion of a building within a horizontal distance of 10 feet. (See Fig. 2a).

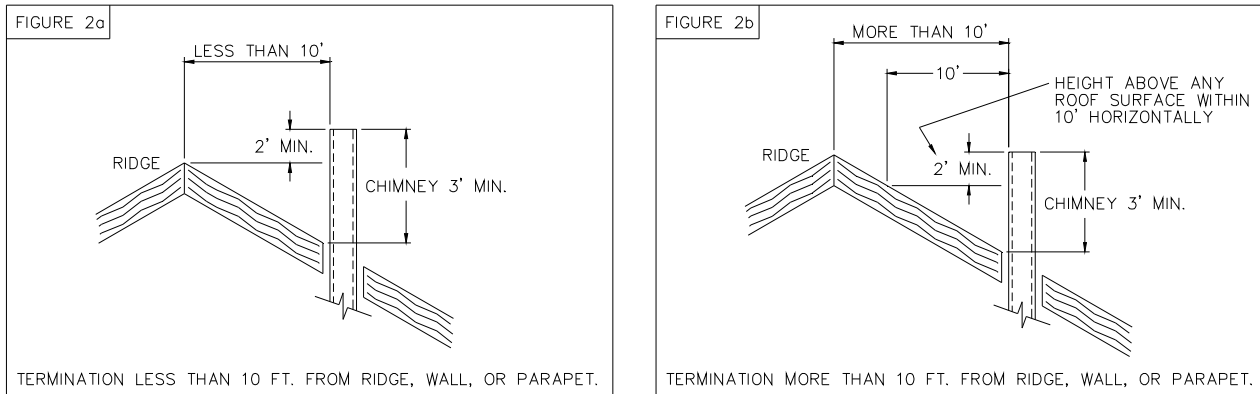

Fig. 2: Proper chimney termination height for pitched roofs

If the chimney penetrates a roof more than 10 feet from a ridge, wall or parapet, a minimum of 3 feet above roof or exit point must be maintained. See Figure 2b.

If the roof is flat rather than the normal residential pitched roof, refer to Figure 3 for proper clearances.

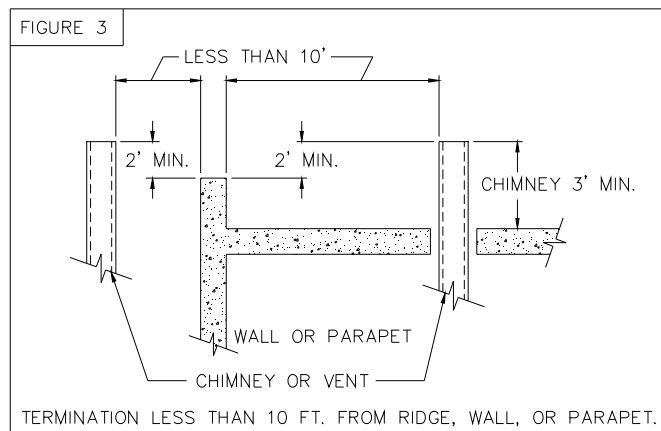

Fig. 3: Proper chimney termination height for flat roofs

3. PROPER VENT CONNECTOR PIPE/CHIMNEY CONNECTION:

The vent connector pipe should extend only to (and not beyond) the inside wall of the chimney (See Fig. 4). A thimble should be used to connect the vent connector pipe to the chimney so that the vent connector pipe may be readily removed in case of inspection or replacement.

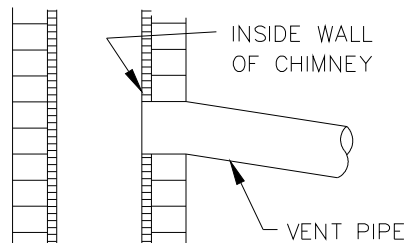

Fig. 4: Proper insertion of the vent connector in the chimney.

4. PROPER CHIMNEY BOTTOM LEVEL:

In cases where the chimney extends to the basement floor, the draft can usually be improved by filling the base of the chimney with sand to within 12 inches of the vent connector pipe after relocating the clean-out door. (See Fig. 5).

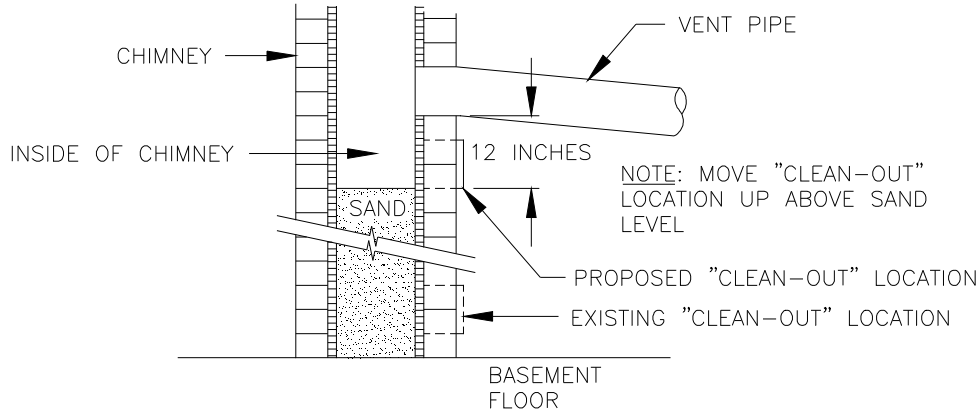

Fig. 5: Suggested method to improve chimney draft.

5. TIGHT JOINTS:

All joints of the chimney must be tightly sealed. The inside of the chimney should be free of any obstructions, such as loose brick, broken pieces of tile, or corroded metal.

6. TIGHT CLEAN-OUT DOORS AND CONNECTIONS:

All chimney clean-out doors and flue connections must fit tightly so they will seal to avoid air leaks.

7. NO INTERCONNECTED CHIMNEY FLUES:

If chimney flues are divided or there are multiple flues within one chimney, make sure there are no openings in the partition separating the divided or individual flues.

8. FLUE PIPE CLEARANCES, SIZING AND TYPE:

The vent connector pipe must not pass through a combustible wall or partition unless adequate protection is provided at the passageway. An acceptable passageway could be either an approved, ventilated metal thimble which is at least 12 inches larger in diameter than the vent connector pipe, or brick work which is at least 8 inches thick constructed into the wall and surrounding the vent connector pipe (See Fig. 6).

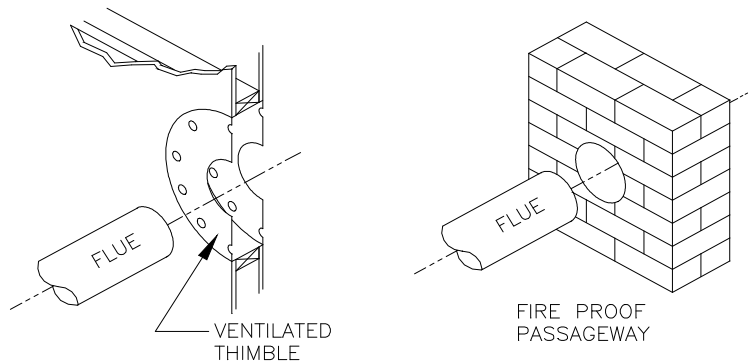

Fig. 6: Suggested method to accommodate vent connector passage through a wall composed of a combustible material.

CONSTRUCTION USING
COMBUSTIBLE MATERIAL,
PLASTERED OR UNPLASTERED.

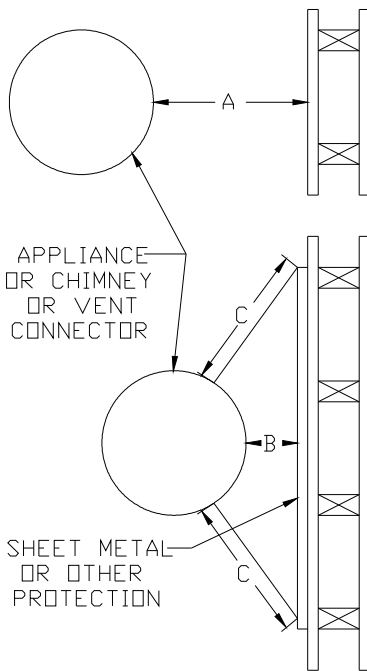

Fig. 7: Alternate constructions that allow reduced clearances to combustibles materials.

REDUCTION OF CLEARANCES WITH SPECIFIED FORMS OF PROTECTION:

Type of protection applied to and covering all surfaces of combustible material within the distance specified as the required clearance with no protection unless otherwise noted, all dimensions in inches, refer to Fig. 7.

Required clearance with no protection from the appliance or chimney connector is:	18 inches		9 inches		6 inches	
	Sides & Above Rear		Sides & Above Rear		Sides & Rear	
a. 3-1/2" thick masonry wall without ventilation air space....	--	12	--	6	--	5
b. 1/2" insulation board over 1" glass fiber or mineral wool batts...	12	9	6	5	4	3
c. 0.024(24 gauge) sheet metal over 1" glass fiber or mineral wool batts reinforced with wire on rear face with ventilated air space...	9	6	5	3	3	3
d. 3- 1/2" thick masonry wall with ventilation air space..	--	6	--	6	--	6
e. 0.024 (24 gauge) sheet metal with ventilated air space.	9	6	5	3	3	2
f. 1/2" thick insulation board with ventilation air space..	9	6	5	3	3	3
g. 0.024 (24 gauge) sheet metal with ventilated air space over 0.024 (24 gauge) sheet metal with ventilated air space....	9	6	5	3	3	3
h. 1" glass fiber or mineral wool batts sandwiched between two sheets 0.024 (24 gauge) sheet metal with ventilated air space	9	6	5	3	3	3

- A. Equal the required clearance with no protection.
- B. Equals the reduced clearance permitted in accordance with the preceding clearance chart.
- C. The protection applied to the construction that covers the combustible material should extend far enough in each direction to make C equal to A.

The vent connector pipe between the furnace and chimney shall be of equal diameter as the flue outlet of the furnace. **The vent connector pipe must be made of 24 gauge (or thicker) corrosion-resistant steel.** The vent connector pipe should be as short as possible and installed so that it has a continuous rise from the furnace to the chimney. The horizontal length of a connector to a natural draft chimney or vent serving a single appliance shall not be more than 75 percent of the height of the vertical portion of the chimney or vent above the connector. Elbows should be minimized and the pipe should be joined with metal screws and supported by straps. All horizontal runs of vent connector pipe should be pitched upward a minimum of ¼ inch per foot of run. A thimble should be used to connect the vent connector pipe to the chimney so the pipe may be readily removed in case of inspection or replacement. See Fig. 6 on preceding page.

B. VENTING:

NOTE: On the VH8F* and VL8F/R* it is possible to rotate the flue elbow (which is factory installed for vertical discharge) 90° counter clockwise. Only the VH8F flue elbow may also be rotated clockwise from the vertical position to adapt to various venting systems.

Notice: Blocked Vent Switch Installation

The blocked vent switch kit must be installed to comply with CAN STD B140.4 where applicable. For installation instructions see AOPS2687 kit.

CAUTION MUST BE TAKEN NOT TO EXCEED 90° ROTATION (OF THE FLUE ELBOW) .

ROTATION OF FRONT FLUE ELBOW:

When an installation requires that the flue exit out the left or right side casing, remove the screw securing the 90 deg. elbow and rotate it 90°. Then, remove knock-out in side casing and extend vent through the opening.

A trim collar may be ordered to hide the gap around the flue pipe. This trim collar, however, is not required for operation. Trim collar/gasket part numbers(s) 14132 / 330006.

The VH8F*, VL8F/R* may be vented through a standard correctly sized chimney.

The VH8F* and VL8F/R may also be horizontally vented through a sidewall. A field model FDVS-67/FOVP-615 side wall vent kit for such applications is available. When installing the sidewall vent kit, outside combustion air must also be applied to the burner. The following table identifies application order information.

SIDE WALL VENTING APPLICATION ORDER INFORMATION			
BURNER	FIELD VENT TERMINATION KIT	SIDE WALL VENT ACCESSORIES KIT	COMBUSTION AIR INTAKE HOOD KIT
	(15' application MAX)	(BURNER SPECIFIC)	(FOR COMBUSTION AIR APPLICATIONS ONLY)
	PART NUMBER	PART NUMBER	PART NUMBER
	VH8F*, VL8F/R*		
Beckett AFG	AOPS8414	AOPS8394	AOPS8397

Table 2: Sidewall vent kits

The Sidewall vent kit is set up with a 6 inch diameter vent pipe for the VH8F* and VL8F/R* with concentric through-the-wall vent termination/inlet air vent hood. For Beckett, the combustion air inlet pipe will be reduced to 3" diameter with the Beckett sidewall vent kit.

The VH8F* side wall vent may be installed either through the knock-out in the right or left side casing of the unit or vertically out the top opening of the vestibule. The VL8F/R* side wall vent may only be installed through the knock-out in the left side casing of the unit or vertically out the top opening of the vestibule.

The combustion air inlet can be installed through the either the lower left side casing knockout or the lower right side casing knockout.

C. DRAFT REGULATORS:

Note: Do not use with Sidewall Vent application.

A draft regulator is supplied with the furnace and should be installed according to the regulator manufacturers recommendations. With the burner operating, use a draft gauge to adjust the regulator to the proper setting. (refer to the instructions enclosed with draft regulator to adjust to the proper setting). When the burner air supply and draft are properly adjusted, the over fire draft should be a negative (-).01" to (-).02" WC, as measured at the 5/16" over fire air tap (See Fig. 12). This tap is provided in the upper burner mounting plate. To measure the flue draft, punch a small hole in the vent connector pipe as close to the furnace as possible and always before the draft regulator.

Note: Draft over fire may be positive for high fire applications but not to exceed (+).01" WC.

D. DUCT WORK/AIR CONDITIONING:

If the furnace is used in connection with summer air conditioning (cooling), the furnace should be installed parallel with or on the upstream side of the evaporator coil to avoid condensation in the furnace heat exchanger. If the cooling unit is installed with a parallel flow arrangement, dampers or other means used to control flow of air should be provided to prevent chilled air from entering the furnace. If such a damper is manually operated, it must be equipped with a means to prevent operation of either unit, unless the damper is in the full heat or cool position.

The duct system should again follow the current design standard of Air Conditioning Contractors of America (ACCA) or ASHRAE Fundamentals volume. The most common location for the A-shaped coil (A style) is shown in Fig. 8.

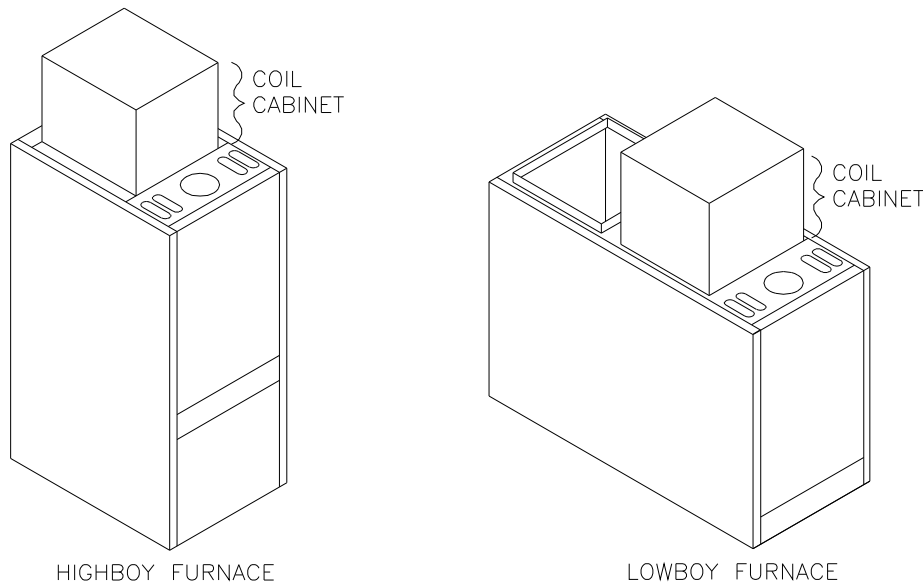

Fig 8: Acceptable locations for the air conditioner evaporator coil.

NOTICE: The minimum coil pan clearance for a sectional or drum type heat exchanger is three inches unless specified otherwise by the individual coil manufacturer.

NOTICE: The minimum return air temperature is 55° F.

The **RETURN AIR DUCT SYSTEM** should equal the warm air duct system in airflow capabilities.

Note: When a return register is located in the same room as the furnace, the register must be at least 20 feet away from the furnace.

E. Air Filter Mounted External to Furnace:

On **highboy** furnaces, it is necessary to cut the return air opening in the side, rear casing or base, depending upon the needs of the specific installation. The filter rack provided with the furnace, refer to Fig. 9, will serve as a template to scribe a mark for the return air opening on the casing. Place the filter rack on a side casing approximately one inch up from the bottom of the furnace and centered from side to side. Place the securing flange against the casing when locating the return air opening. For your convenience, (4) locator knockouts have been placed at the proper locations on both the left and right side casings.

PLEASE NOTE: While scribing the return air opening, the filter rack can be held in position by tape or similar temporary means. Position the open end of the filter rack so as to provide access for filter replacement. Once the filter rack is positioned correctly, scribe a line along the inside of the securing flange on three of the sides. To scribe a line on the fourth side (the open end), use the open-end support as a guide.

Remove the filter rack and cut the return air opening in the casing. Now the filter rack can be anchored to the furnace with screws or pop-rivets through the securing flange of the filter rack.

Connect the return air plenum to the filter rack and slide the filter into place. Dimensions for adapting the return air plenum to the filter rack are provided (See Fig. 9).

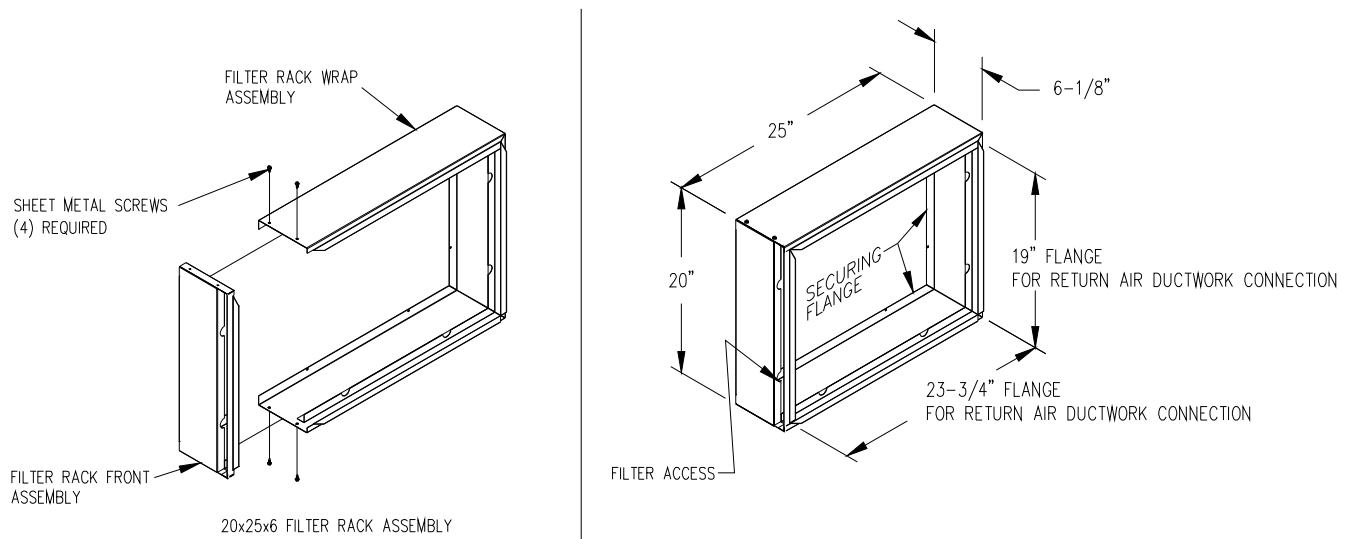

Fig. 9: A typical filter rack and dimensions for the VH8 furnace.

CAUTION: Failure to comply with minimum filter installation requirements may affect the performance and/or void the warranty on this unit.

If a method other than supplied filter rack is selected for retention of the filter and/or use of a different filter type is desired, refer to Table 3 below for minimum sizing guidelines for selecting filters for the unit.

Filter Type	Maximum Air Velocity (ft/min)	Model Number	
		VH8F*	VL8F/R*
* Supplied Permanent	600	480 in ²	(2) 264 in ²
Standard Permanent	500	576 in ²	576 in ²
Disposable	300	960 in ²	960 in ²

Table 3: Minimum Required Filter Area (in square inches)

* The supplied filter can be cut to size to fit other filter retention systems as long as maximum air velocity of the filter is not exceeded.

NOTICE: Any internal stiffeners used in the filter must not be removed, although they can be cut to size as needed.

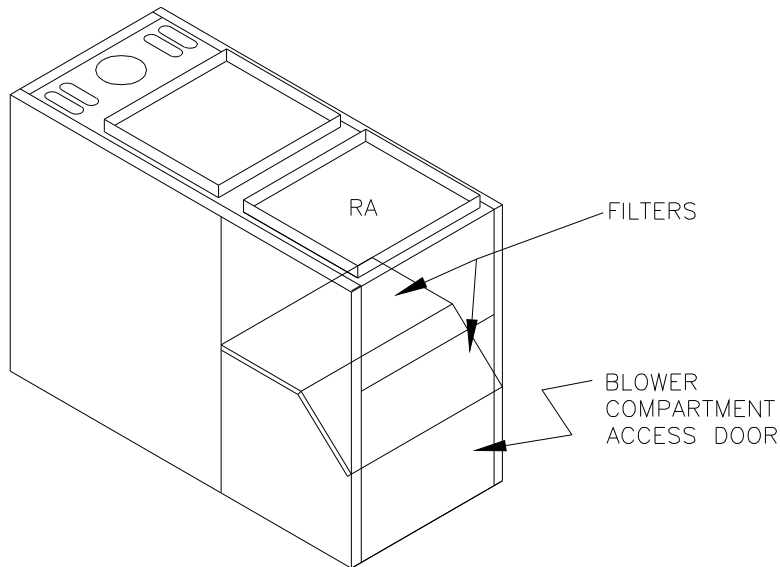

Fig. 9A: Filter rack location for VL8* furnace.

F. LIMIT POSITION AND LOCATION

WARNING: The predetermined limit locations on all of the Spirit oil-fired furnaces have been tested and approved. Any attempt to relocate these safety controls or replace these safety controls with a control that is not approved, or is incompatible, may result in personal injury, substantial property damage or death.

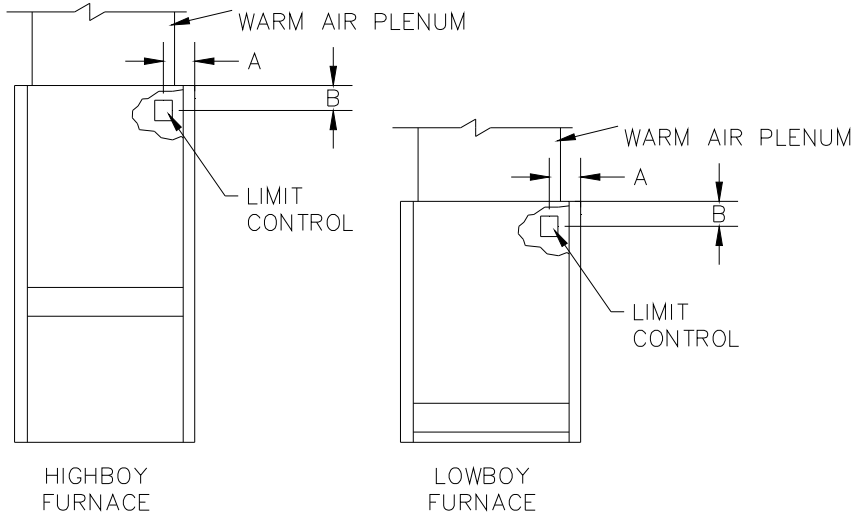

TABLE 4: Installation location of the fan and limit control for each furnace

DIM.	A	B
MODEL		
VH8F*	4-3/4"	1-5/8"
VL8F*	4-3/4"	2-1/4"
VL8R*	4-3/4"	2-1/4"

Fig. 10: Limit location

G. BURNER INSTALLATION:

NOTICE: Remove all cardboard packing from around chamber before installing burner.

The oil burner will mount on three stud mounting bolts on the lower mounting plate covering the opening in the front of the heat exchanger. The end of the burner tube should be inserted no further than 1/4 inch back from the inside surface of the combustion chamber. A distance further than 1/4 inch back from the inside chamber wall may cause impingement and sooting. This unit is equipped with a chamber retainer (refer to Fig.11). The retainer secures the chamber during shipping and helps to maintain insertion depth.

DO NOT remove this retainer when installing burner.

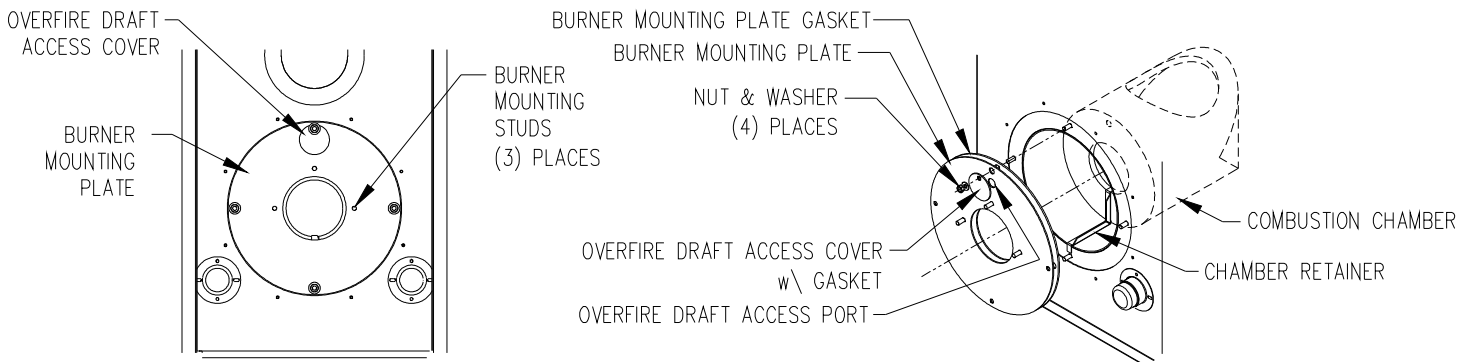

Fig. 11: Typical location of the over fire air tap and components in burner mounting plate area

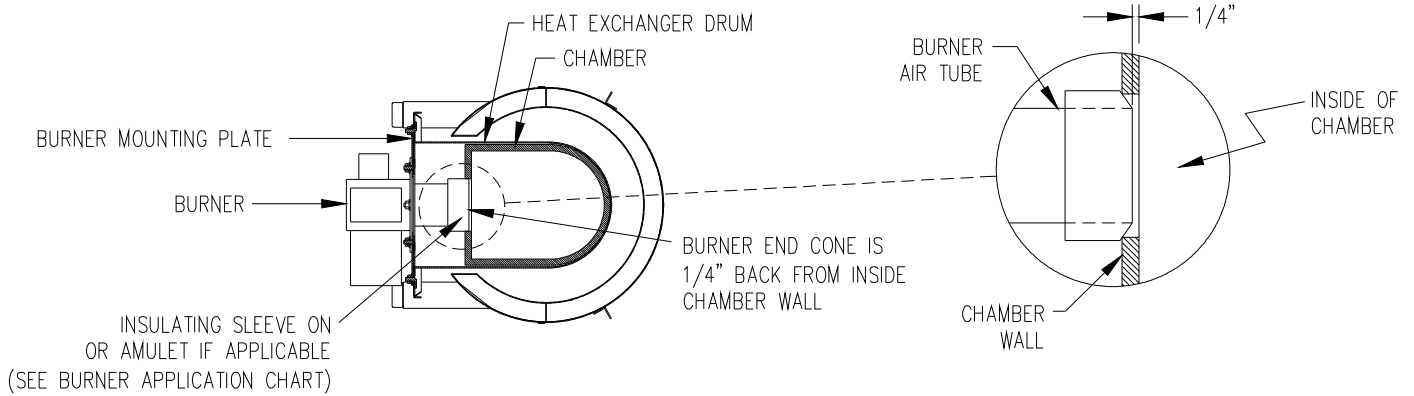

Fig. 12: Burner insertion illustration (Top view)

When mounting the burner, the mounting plate (Fig. 11) must be removed to provide access to the area in front of the combustion chamber. A fiber insulating sleeve or amulet is provided on the burner tube of specific burners.(see Fig. 12). See burner application chart for type of insulator. Do not allow the burner tube or end cone to physically touch or protrude into the chamber, as excess heat transfer could result in destruction of the tube, end cone or both. The burner tube/end cone is properly positioned, when the end is ¼ inch back from the inside surface of the combustion chamber wall.

DO NOT CHANGE POSITION OF THE CHAMBER!

H. BURNER SPECIFICATIONS AND APPLICATIONS:

FURNACE MODEL VH8FA119*60B VL8*A119P60B BURNER	BURNER SPEC NO.	* INS	BURNER MODEL & TUBE LENGTH	HEAD	STATIC PLATE	MAXIMUM NOZZLE SIZE**	SHIPPED NOZZLE SIZE	OIL PUMP PRESSURE (PSIG)
BECKETT (AFG)	TP2701	N	AFG-4.5"	F6	2-3/4U	1.10X80° A	1.00X80° A	120

Table 5: Burner specifications

* INSULATOR S = SLEEVE OR N = NONE

THE NOZZLE SIZE GIVES THE NOMINAL FLOWRATE, IN GPH, FOLLOWED BY THE SPRAY ANGLE, IN DEGREE'S, AND THE SPRAY PATTERN, EITHER "A" FOR HOLLOW CONE OR "B" FOR SOLID CONE. FOR EXAMPLE, A NOZZLE RATED AT 0.65 GPH @ 100 PSIG THAT PROVIDES AN 80° SPRAY ANGLE AND A HOLLOW SPRAY PATTERN WOULD BE ABBREVIATED IN THE TABLE AS "0.65 X 80°A".

INPUT CAPACITY SELECTION CHART				
UNITS	EQUIVALENT HEAT INPUT RATE* (BTU/HR)	EFFECTIVE HEATING CAPACITY** (BTU/HR)	NOZZLE SIZE (GPH x TYPE)	
			Beckett AFG	
VH8F, VL8F/R	119,000	101,000	0.85 x 80° A	
VH8F, VL8F/R	140,000	119,000	1.00 x 80° A	
VH8F, VL8F/R	156,250	132,000	1.10 x 80° A	

Table 6: Oil nozzle capacity

All rates shown achieved with 120 PSIG pump pressure for Beckett AFG.

* Based on #2 domestic heating fuel oil having heating value of 140,000 BTU per gallon.

** Based on thermal efficiency of 85%.

I. OIL TANK AND PIPING:

⚠WARNING: All local codes and ordinances take precedence with regard to selection and installation of oil storage tank and oil supply (and return) lines. In the absence of local codes, all tanks and lines must be selected and installed according to the instructions in this manual and the Standard for the Installation of Oil-Burning Equipment, NFPA 31-1997, or the latest edition.

Burners are equipped with a single-stage, fuel pump. This type of fuel pump, when connected with a supply line only, is satisfactory where the fuel supply is level with, or above the burner thus permitting gravity flow of oil to the burner. If the tank is above the burner, and gravity oil feed to the burner is permitted, a single line system may be used. The line should have a gradual slope downward of approximately 1/2 inch per foot, or more, from the tank to a point directly below where it is connected to the pump. Pitching the line upward toward the tank will help prevent the formation of air pockets in the line.

NOTICE: An oil safety valve or a delayed-action, solenoid valve should be installed in the oil supply line of all gravity-fed systems.

J. OIL FILTER:

It is strongly recommended that an oil filter assembly be installed in the oil supply line to the unit. This filter should have the capacity to trap a 40-50 micron particle.

The filter cartridge should be replaced at least once a year. The filter body should be thoroughly cleaned before installing a new cartridge.

K. ELECTRICAL WIRING:

⚠WARNING: This appliance must be grounded in accordance with local codes, or in the absence of local codes, with the National Electrical Code, ANSI/NFPA 70-1999, or the latest edition.

All wiring must conform to the provisions of local codes or, in the absence of local codes, with the provisions of the National Electrical Code, ANSI/NFPA 70-1999, or the latest edition, and this instruction manual.

This appliance requires 120 VAC, 60 Hz, single-phase power. Refer to Table 7 for typical electrical current draws of the individual appliance motors, recommended sizes for over-current and short circuit devices, and minimum recommended field wiring sizes. Electrical service must be brought to the unit from a circuit breaker, or fused disconnect switch, in accordance with local codes. The disconnecting switch must be located reasonably close to and within sight of the unit. Care must be taken to ensure correct polarity when wiring the furnace.

Model	Potential/Frequency/ No. of Phases (V/Hz/Ph)	Supply/Return Air Blower Full Load Current (Amps) @ 115 VAC	Oil Burner Assembly Full Load Current (Amps) @ 115 VAC	Maximum Time Delay Type Fuse or Inverse Time Circuit Breaker Size (Amps)	Minimum Recommended 75 deg. C. Copper Power Wiring Size (AWG)
VH8FA119P*	120/60/1	19.2	2.6	20	12
VH8FA119T*	120/60/1	11	2.6	20	12
VL8FA119P*	120/60/1	12.2	2.6	20	12
VL8RA119P*	120/60/1	12.5	2.6	20	12

Table 7: Typical Electrical Requirements

Field wiring of power circuits to the appliance should consist of copper conductors rated for at least 15 amp service with an insulation temperature rating of at least 75°C temperature rise.

Wire size selections in Table 7 are based upon Table 310-16 of the National Electrical Code for three copper conductors, with insulation rated for 75 degrees Celsius, contained in raceway at 30 degrees Celsius. For other wire insulation temperature ratings and ambient conditions, refer to the National Electrical Code for the minimum wire sizing requirements.

NOTICE: Before the unit is started, the installer and/or electrician must check the following items:

1. Review wiring diagram for proper routing and connection of all field wiring. Ensure that all wires and connectors are firmly secured.

Electronic Air Cleaner (EAC) and Humidifier Installation:

The fan timer on this unit has designated terminals to control the operation of an electronic air cleaner and/or humidifier. These terminals provide line voltage for the control of these accessories, refer to Figure 13. Connection between EAC and N6 provides a switched 115 vac to power an electronic fan cleaner. The same-switched 115 vac is available between FAN and N7 and may be used in conjunction with a humidistat to control a humidifier. These terminals are energized whenever the blower is active.

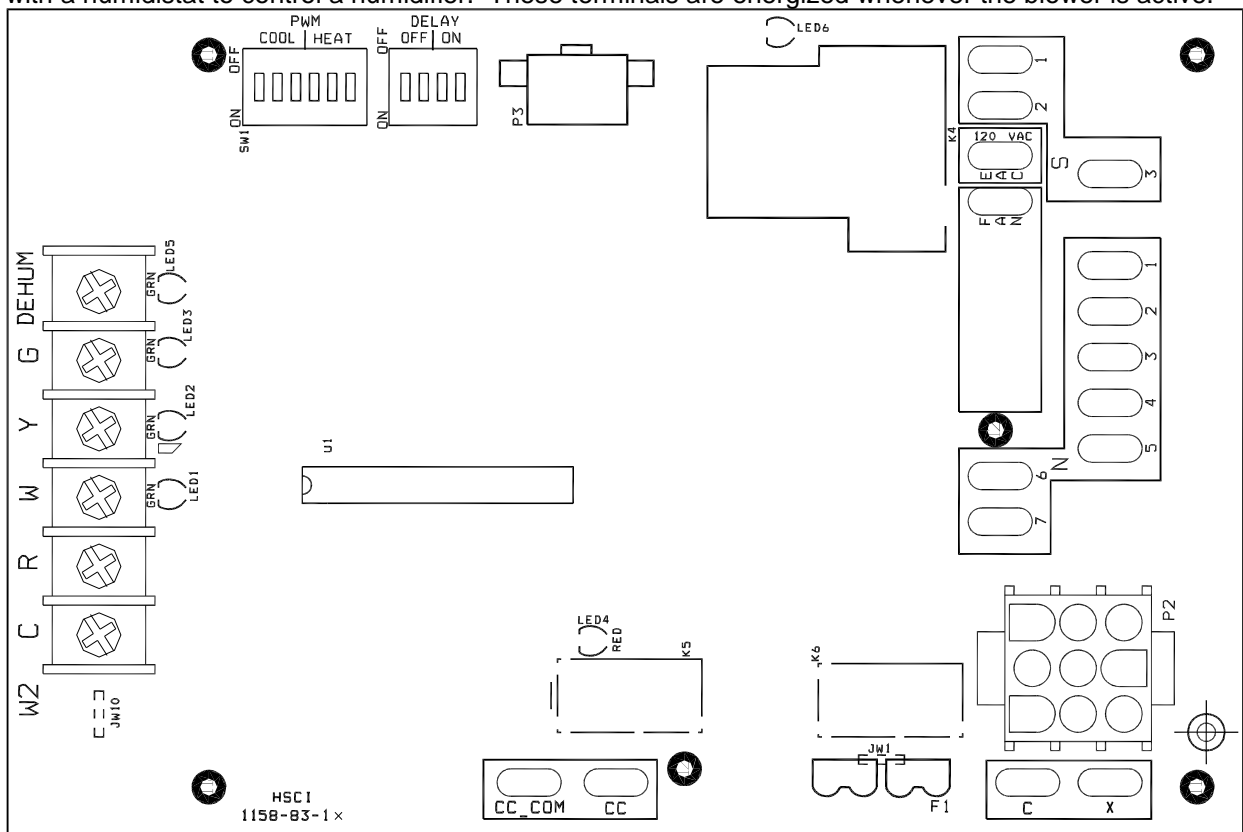

Figure 13: The Fan Control Module

NOTICE: It is important to confirm that the operating voltage of the humidifier or EAC being installed matches the output of this control. If not, a field supplied relay or transformer may be necessary to provide the proper control and supply voltage for the accessory being installed. Refer to the manufacturer’s instructions for the humidifier or EAC for additional information.

Thermostat Anticipator Setting:

Proper control of the indoor air temperature can only be achieved if the thermostat is calibrated to the heating and/or cooling cycle. Calibration will help to produce a more constant indoor temperature by adjusting the length of the heating/cooling cycle to fit the application. A vital consideration of this calibration is related to the thermostat heat anticipator.

The proper thermostat heat anticipator setting is 0.1 ampere. To increase the length of the cycle, increase the setting of the heat scale; to decrease the length of the cycle, decrease the setting of the heat scale. Thermostat models having a scale as shown in Figure 14 on the next page, must be adjusted to each application.

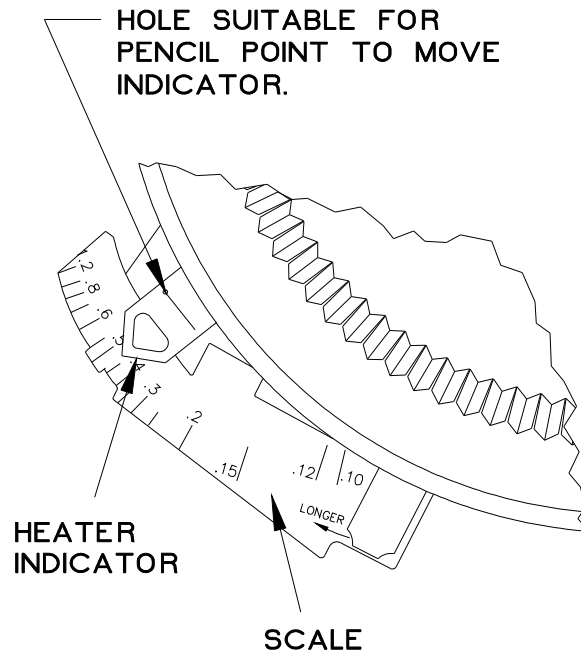

Figure 14: Heat Anticipator Adjustment Scale

In many cases, this setting can be found in the thermostat installation instructions. If this information is not available, or if the correct setting is questioned, the following procedures should be followed:

L. Blower Motor Speed Selection:

⚠WARNING: Turn off the electrical power to the unit, before attempting to change supply air blower speed wiring.

The furnace comes from the factory with the proper cooling speed selected and the heat rise set to approximately 66°F on mid-fire.

The heat rise is determined by the nozzle size and the switch selection on the control board located in the vestibule compartment.

VH8FA119P60B

ALTERATIONS REQ'D FOR A/C @ DESIGN EXTERNAL STATIC PRESSURE				
COOLING UNIT	HTG Speed by Input			Recommended CLG Speed
	Low Fire	Mid Fire	High Fire	
36,000	Low	ML	MH	Low
42,000	Low	ML	MH	Med Low
48,000	Low	ML	MH	Med High
60,000	Low	ML	MH	High

AS SHIPPED CLG. →

Speed Tap\ Static Pressure	Furnace Airflow (CFM) vs. External Static pressure (in. WC.)							
	0.1	0.2	0.3	0.4	0.5	0.6	0.7	
Low	1308	1300	1274	1265	1237	1169	1127	
ML	1583	1526	1515	1491	1458	1420	1371	
MH	1894	1874	1839	1804	1746	1683	1632	
High	2254	2228	2195	2181	2069	1995	1897	

Speed Tap\ Static Pressure	Furnace Motor Current Draw (Amps/Watts) vs. External Static pressure (in. WC.)							
	0.1	0.2	0.3	0.4	0.5	0.6	0.7	
Low	7.56 698	6.99 660	6.66 637	6.50 623	6.21 602	5.91 578	5.83 568	
ML	9.21 867	8.44 801	8.19 786	8.01 772	7.61 745	7.28 715	6.93 687	
MH	10.6 1040	10.2 999	9.87 971	9.38 923	9.01 895	8.68 864	8.23 829	
High	13.5 1320	13.2 1290	12.8 1270	12.4 1240	11.3 1130	10.7 1090	10.2 1020	

Speed Tap\ Static Pressure	High Fire Temperature Rise vs. External Static pressure (in. WC.)							
	0.1	0.2	0.3	0.4	0.5	0.6	0.7	
Low	94	94	96	97	99	105	108	
ML	78	80	81	82	84	86	90	
MH	65	66	67	68	70	73	75	
High	54	55	56	56	59	62	65	

AS SHIPPED HTG. →

Speed Tap\ Static Pressure	Mid Fire Temperature Rise vs. External Static pressure (in. WC.)							
	0.1	0.2	0.3	0.4	0.5	0.6	0.7	
Low	84	84	86	87	89	94	98	
ML	70	72	73	74	76	78	80	
MH	58	59	60	61	63	65	68	
High	49	49	50	51	53	55	58	

Speed Tap\ Static Pressure	Low Fire Temperature Rise vs. External Static pressure (in. WC.)							
	0.1	0.2	0.3	0.4	0.5	0.6	0.7	
Low	72	72	73	74	76	80	83	
ML	59	61	62	63	64	66	68	
MH	49	50	51	52	54	56	57	
High	42	42	43	43	45	47	49	

Figure 15a: Heating speed by input VH8FA119P*

Speed vs color code for *PSC Motor:

- Low = Red
- Med-Low = Blue
- Med-High = Yellow
- High = Black

*PSC is an abbreviation for Permanent Split Capacitor

Speed vs. color code for *CTM Motor:

- Low = Red
- Med-Low = Purple
- Medium = Blue
- Med-High = Yellow
- High = Black

*CTM is an abbreviation for Constant Torque Motor

VH8FA119T60B

ALTERATIONS REQ'D FOR A/C @ DESIGN EXTERNAL STATIC PRESSURE				
COOLING UNIT	HTG Speed by Input			Recommended CLG Speed
	Low Fire	Mid Fire	High Fire	
36,000	ML	Med	MH	Low
42,000	ML	Med	MH	Med Low
48,000	ML	Med	MH	Med High
60,000	ML	Med	MH	High

AS SHIPPED CLG. →

Speed Tap\ Static Pressure	Furnace Airflow (CFM) vs. External Static pressure (in. WC.)						
	0.1	0.2	0.3	0.4	0.5	0.6	0.7
Low	1520	1429	1385	1311	1222	1139	1085
ML	1660	1593	1536	1491	1422	1369	1295
Med	1749	1693	1652	1572	1520	1465	1391
MH	1827	1766	1692	1674	1596	1540	1487
High	2253	2185	2142	2114	2045	1991	1955
Speed Tap\ Static Pressure	Furnace Motor Current Draw (Amps/Watts) vs. External Static pressure (in. WC.)						
	0.1	0.2	0.3	0.4	0.5	0.6	0.7
Low	2.62 211	2.81 228	2.92 237	3.07 253	3.22 268	3.35 279	3.46 289
ML	3.34 279	3.55 294	3.72 310	3.84 325	4.02 339	4.13 350	4.31 364
Med	3.74 314	3.91 327	4.11 345	4.25 360	4.39 374	4.60 390	4.74 406
MH	4.21 356	4.40 373	4.57 390	4.73 407	4.90 422	5.01 432	5.12 450
High	7.2 638	7.2 650	7.43 665	7.68 688	7.92 712	8.16 714	8.29 751

Speed Tap\ Static Pressure	High Fire Temperature Rise vs. External Static pressure (in. WC.)						
	0.1	0.2	0.3	0.4	0.5	0.6	0.7
Low	80	85	88	93	99	105	112
ML	73	76	79	81	85	89	94
Med	69	72	73	77	80	83	87
MH	66	69	72	72	76	79	82
High	54	56	57	57	59	61	62

AS SHIPPED HTG. →

Speed Tap\ Static Pressure	Mid Fire Temperature Rise vs. External Static pressure (in. WC.)						
	0.1	0.2	0.3	0.4	0.5	0.6	0.7
Low	72	77	80	84	90	97	102
ML	66	69	72	74	77	80	85
Med	63	65	67	70	73	75	79
MH	60	62	65	66	69	72	74
High	49	50	51	52	54	55	56

Speed Tap\ Static Pressure	Low Fire Temperature Rise vs. External Static pressure (in. WC.)						
	0.1	0.2	0.3	0.4	0.5	0.6	0.7
Low	62	66	68	71	77	82	86
ML	56	59	61	63	66	68	72
Med	54	55	57	60	62	64	67
MH	51	53	55	56	59	61	63
High	42	43	44	44	46	47	48

Figure 15b: Heating speed by input VH8FA119T*

VL8FA119P60B

ALTERATIONS REQ'D FOR A/C @ DESIGN EXTERNAL STATIC PRESSURE				
COOLING UNIT	HTG Speed by Input			Recommended CLG Speed
	Low Fire	Mid Fire	High Fire	
36,000	Low	ML	MH	Low
42,000	Low	ML	MH	Med Low
48,000	Low	ML	MH	Med High
60,000	Low	ML	MH	High

AS SHIPPED CLG. →

Speed Tap\ Static Pressure	Furnace Airflow (CFM) vs. External Static pressure (in. WC.)							
	0.1	0.2	0.3	0.4	0.5	0.6	0.7	
Low	1362	1344	1293	1256	1234	1167	1111	
ML	1645	1611	1599	1556	1496	1445	1389	
MH	1896	1868	1818	1779	1710	1643	1561	
High	2356	2235	2168	2087	2012	1919	1845	
Furnace Motor Current Draw (Amps/Watts) vs. External Static pressure (in. WC.)								
Low	6.8 649	6.5 639	6.4 620	6.1 610	6.0 595	5.9 589	5.6 574	
ML	8.4 819	8.3 801	7.9 793	7.8 781	7.6 765	7.3 741	6.9 710	
MH	9.9 977	9.6 961	9.1 915	8.5 885	8.3 857	7.8 833	7.5 798	
High	12.2 1280	11.6 1220	11.1 1160	10.7 1130	10.4 1090	10.0 1050	9.8 1020	

Speed Tap\ Static Pressure	High Fire Temperature Rise vs. External Static pressure (in. WC.)							
	0.1	0.2	0.3	0.4	0.5	0.6	0.7	
Low	90	91	95	98	100	105	111	
ML	75	76	77	79	82	85	89	
MH	65	66	68	69	72	75	79	
High	52	55	57	59	61	64	67	

AS SHIPPED HTG. →

Speed Tap\ Static Pressure	Mid Fire Temperature Rise vs. External Static pressure (in. WC.)							
	0.1	0.2	0.3	0.4	0.5	0.6	0.7	
Low	81	82	85	88	89	94	99	
ML	67	68	69	71	74	76	79	
MH	58	59	61	62	64	67	71	
High	47	49	51	53	55	57	60	

Speed Tap\ Static Pressure	Low Fire Temperature Rise vs. External Static pressure (in. WC.)							
	0.1	0.2	0.3	0.4	0.5	0.6	0.7	
Low	69	70	72	75	76	80	84	
ML	57	58	59	60	63	65	67	
MH	49	50	52	53	55	57	60	
High	40	42	43	45	47	49	51	

Figure 15c: Heating speed by input VL8FA119P*

Speed vs. color code for *PSC Motor:
 Low = Red
 Med-Low = Blue
 Med-High = Yellow
 High = Black

*PSC is an abbreviation for Permanent Split Capacitor

VL8RA119P60B

ALTERATIONS REQ'D FOR A/C @ DESIGN EXTERNAL STATIC PRESSURE				
COOLING UNIT	HTG Speed by Input			Recommended CLG Speed
	Low Fire	Mid Fire	High Fire	
36,000	Low	ML	MH	Low
42,000	Low	ML	MH	Med Low
48,000	Low	ML	MH	Med High
60,000	Low	ML	MH	High

AS SHIPPED CLG. →

Speed Tap\ Static Pressure	Furnace Airflow (CFM) vs. External Static pressure (in. WC.)						
	0.1	0.2	0.3	0.4	0.5	0.6	0.7
Low	1329	1330	1315	1282	1238	1189	1158
ML	1598	1576	1572	1546	1489	1404	1355
MH	1863	1842	1829	1787	1730	1690	1604
High	2218	2160	2136	2066	1998	1942	1845
Furnace Motor Current Draw (Amps/Watts) vs. External Static pressure (in. WC.)							
Low	7.0 649	6.7 635	6.3 611	6.2 596	6.0 579	5.8 560	5.7 551
ML	8.5 816	7.9 769	8.2 786	7.9 739	7.3 715	6.9 677	6.6 657
MH	9.9 960	9.4 938	9.1 903	8.8 883	8.7 870	8.5 853	8.0 804
High	12.0 1210	11.3 1150	11.0 1110	10.5 1070	10.3 1040	10.1 1010	9.5 958

Speed Tap\ Static Pressure	High Fire Temperature Rise vs. External Static pressure (in. WC.)						
	0.1	0.2	0.3	0.4	0.5	0.6	0.7
Low	93	92	94	96	99	103	106
ML	77	78	78	80	83	88	91
MH	66	67	69	69	71	73	77
High	55	57	58	60	62	63	67

Speed Tap\ Static Pressure	Mid Fire Temperature Rise vs. External Static pressure (in. WC.)						
	0.1	0.2	0.3	0.4	0.5	0.6	0.7
Low	81	83	84	86	89	93	95
ML	69	70	70	71	74	78	81
MH	59	60	60	62	64	65	69
High	50	51	52	53	55	57	60

AS SHIPPED HTG. →

Speed Tap\ Static Pressure	Low Fire Temperature Rise vs. External Static pressure (in. WC.)						
	0.1	0.2	0.3	0.4	0.5	0.6	0.7
Low	70	70	71	73	76	79	81
ML	59	59	60	61	63	67	69
MH	50	51	52	52	54	55	58
High	42	43	44	45	47	48	51

Figure 15d: Heating speed by input VL8RA119P*

Speed vs. color code for *PSC Motor:

- Low = Red
- Med-Low = Blue
- Med-High = Yellow
- High = Black

*PSC is an abbreviation for Permanent Split Capacitor

M. BLOWER CONTROLLER INFORMATION FOR PSC AND CTM MOTOR

TERMINAL DEFINITIONS & FIELD WIRING

Burner Harness Connector P1

- Pin 1- Limit switch connector.
- Pin 2- 120 VAC Line connection.
- Pin 3- Burner pilot contact.
- Pin 4&5- 120 VAC Neutral connections.
- Pin 6- Burner pilot contact.
- Pin 7&8- From oil primary control.
- Pin 9- Limit Switch Input (LSI).

Field Wiring to Burner

	Pilot (Tstat)	Neutral	Line
Harness Wires	Yellow Wires	White	Red
Beckett Connections	T-T terminals	White	Black
Riello Connections	T-stat terminals	White	Black

Thermostat / Humidistat connections

- "C" Common / ground
- "W" Thermostat call for heat
- "R" 24 VAC to thermostat
- "G" Thermostat call for fan
- "Y" Thermostat call for cool
- "DEHUM" Humidistat call for dehumidification (TXV systems ONLY)

Male quick connect terminals.

- "S1-3" 120 VAC Hot
- "N1-7" 120 VAC Neutral
- "EAC" Electronic Air Cleaner (120 VAC) connection
- "FAN" Fan On Signal
- "X" 24 VAC from transformer
- "C" 24 VAC common from transformer
- "CC" Compressor Contactor
- "CC_COM" Compressor Contactor Common
- "LOW" Continuous Blower Speed
- "HEAT" Blower heat speed tap
- "COOL" Blower cool speed tap

A. Inputs

Power supplies

Line voltage is applied between the “S1” and “N1” quick connect terminals. 24 VAC Class II Transformer secondary voltage supplied to X and C

Limit switch

The 120 VAC optically isolated limit switch input is connected on pin P2-1 & 9. Refer to the Heat Mode section for the control operation.

Thermostat call for heat “W”

24 VAC thermostat input. A call for heat is recognized when the thermostat connects “W” to “R”. This input has an indicator LED that will light when the control receives a call for heat. Refer to the Heat Mode section for the control operation.

Thermostat call for cool, “Y”

24 VAC thermostat input. A call for cooling is recognized when the thermostat connects “Y” to “R”. This input has an indicator LED that will light when the control receives a call for cooling. Refer to the Cool Mode section for the control operation.

Thermostat call for dehumidification “DEHUM”

24 VAC thermostat input. A call for dehumidification is recognized when the humidistat connects “DEHUM” to “R”. This input has an indicator that will light when the control receives a call for dehumidification. Refer to the Cool Mode section for the control operation.

Thermostat call for fan “G”

24 VAC thermostat input. A call for fan is recognized when the thermostat connects “G” to “R”. This input has an indicator LED in that will light when the control receives a call for fan. Refer to the Fan Mode section for the control operation.

B. Outputs

PSC Control

The control shall control a five-speed indoor blower motor. Rating shall be 10 FLA, 30 LRA @ 120 VAC. Connections are made via 0.250 x 0.032” male quick connect terminals labeled “HEAT”, “COOL”, and “LOW”. “HEAT” is energized when the heat speed blower is to run. “COOL” is energized when the Cool speed blower is to run. “LOW” is energized during a call for fan is received or a call for dehumidification is received.

Oil Burner

Control

The control provides dedicated contacts to operate the T-T input of an oil primary control. Rating shall be class 2 – 24 VAC pilot duty @ 24 VAC (<200mA).

Power

The switched 120 VAC power from the LIMIT switch passes through the board between Pins 1 & 2 of connector P1.

Compressor contactor

The control provides switched 24VAC to operate a compressor contactor. Rating shall be class 2 – 24 VAC pilot duty @ 24 VAC (<200mA).

EAC (electronic air cleaner)

The control provides a 120 VAC output for an electronic air cleaner. This output is energized whenever the fan motor is energized (either low, heat or cool speed). Connection is made via male quick connect terminal labeled "EAC".

Humidifier

The control provides a 120 VAC output for a humidifier. Connections are made to a male quick connect terminal labeled "FAN". The control does not switch this output, it provides a pass-through connection from P1-7 from the switched primary voltage of the Burner Module.

Status LED

A red LED is provided to indicate any thermostat input has been recognized by the microprocessor on the control. See Diagnostic Features for a function description of operation.

Thermostat Input LEDs

Four green LEDs are placed beneath their respective thermostat connections (W, Y, G and DEHUM) and operate whenever a call is present. See Diagnostic Features for a function description of operation.

C. Operating Modes

Standby Mode

All outputs are off and the control is waiting for a thermostat demand. The thermostat inputs, and limit switch are continuously monitored. The control initiates action when a thermostat call is received or limit switch opens.

Fan Mode

A call for fan ("G") is received from the thermostat. If no other mode is calling for blower operation, the control will operate the fan relay (K4) and power the "Low" blower speed terminal. The fan mode will be operated as long as the "G" input is calling and neither the Heat mode nor the Cool mode is calling for blower operation. When the Heat and Cool modes call for blower operation, their respective outputs will take precedence after their respective turn-on time delays have expired.

Cooling Mode

A call for cool ("Y") is received from the thermostat. If the heat mode is not active or the anti-short cycle delay is not in effect, the control will energize the "CC" terminal and after a 10 second power demand conservation delay energizes the "COOL" speed blower terminal.

When the call for cool is satisfied, the "CC" terminal is de-energized and the cooling off delay of 45 seconds is started. Forty-five seconds later the "COOL" speed blower terminal is de-energized and the control reverts to Standby Mode.

Dehumidification Operation

If a call for dehumidification is received while the Cool Mode is active, blower speeds will be reduced. The PSC "COOL" blower speed terminal (1158-100 model only) will be de-energized and "Low" blower speed will be energized.

Anti-Short Cycle Operation

To prevent compressor short cycling, a call for cooling will be ignored for four minutes after the termination of any cooling call. The anti-short cycle delay is also in effect at power-up.

Heat Mode

When a call for heat (“W”) is received from the thermostat, if the “Cool” mode is not already active, the “T-T” terminal is energized and the blower on delay is started. The on-off pattern of DIP switch SW2 (positions 1 and 2) select one of four blower on delay values (see Table 11). When the delay time has elapsed, the “HEAT” blower speed is energized. The control remains in steady heat mode until the thermostat is satisfied. When the call for heat signal is removed, the “T-T” terminal is de-energized and the blower off delay is started. The on-off pattern of DIP switch SW2 (positions 3 and 4) select one of four blower off delay values (see Table 8). When the delay time has elapsed, the “HEAT” blower speed terminal is de-energized.

DIP SWITCH 2 SECTION STATE				BLOWER DELAY TIMES		
1	2	3	4	Counter Flow ON - SEC	ON - SEC	OFF - MIN
OFF	OFF			15	30	
ON	OFF			24	60	
OFF	ON			36	120	
ON	ON			48	240	
		OFF	OFF			2
		ON	OFF			4
		OFF	ON			6
		ON	ON			8

Table 8: ON and OFF Blower Delay Time Switch Settings

Motor Blower Speed

Three interconnected blower speed outputs are provided. A “G” call for fan will provide power to the LOW speed tap only. A “W” heat call will provide power to the Heat speed tap only. A “Y” cooling call will provide power to the Cool speed tap only.

In the case of thermostat calls for “Y” and “W” together, blower speed selection will be determined by the input that was first initiated. In the case where the control is in a cooling mode with both “Y” and “W” inputs energized and then the “Y” input is removed, the cooling blower off time will be executed prior to the control switching into a heating mode. In the case where the control is in a heating mode with both “Y” and “W” inputs energized and then the “W” input is removed, the heating blower off time will be executed prior to the control switching into a cooling mode. In the case where a call for fan “G” already exists and either a “W” or a “Y” call is initiated, the blower speed will switch to the respective “W” or a “Y” speed following the blower on delay for that call.

The speed taps are interconnected and interlocked, only one speed may be powered at any one time. When a speed is to be operated, the speed select relays are operated to select the path to the motor tap and then the enable relay is operated to switch the operating power to the selected motor speed tap. If the speed of the running motor is to be changed, first the enable relay removes power from the motor, the new speed is selected and then power is restored to the motor.

Blower On and Off Delays

Four Heat blower on and four blower off delays are selected by two dip switches for each function. Refer to Table 11 for specific delay values.

PSC AND CTM TROUBLE SHOOTING

DIAGNOSTIC FEATURES

The control board is equipped with 4 green Input Status LEDs and 1 red Board Status LED. These are intended to provide a quick view into furnace performance without requiring a voltmeter.

The green Input Status LEDs are driven by the “Y”, “W”, “G”, and “DEHUM” inputs and are located directly below those inputs. They will light to indicate the presence of these signals.

The red Board Status LED has two functions:

It will light when the board recognizes a valid input signal and will stay lit until all valid signals are removed. This is intended to show that the board is functioning and able to respond to input signals.

It will flash rapidly while 120VAC is missing from the LIMIT switch. This is intended to give a quick visual indication of the High Limit switch.

N. STARTUP PROCEDURES:

A. Heating System

1. Initial Startup:

⚠WARNING: Turn off power to furnace. Before the oil piping system is placed into service, it must have been leak tested by a qualified heating contractor.

⚠WARNING: For initial start-up of the appliance after installation, it may be necessary to purge the air out of the oil line. A qualified heating contractor should do this.

For Your Safety Read Before Operating:

⚠WARNING: If you do not follow these instructions exactly, a fire or explosion may result causing property damage, personal injury or loss of life.

- This appliance does not have a pilot light. It is equipped with an ignition system that automatically lights the burner. Do not attempt to light the burner by hand.
- Do not use this appliance if any part has been under water. Immediately call a qualified service technician to inspect the appliance and to replace any part of the control system and any oil control that has been under water.

Operating Instructions:

- i. **STOP! Read the safety information above.**
- ii. Set the thermostat to the lowest setting.
- iii. Turn off all electric power to the appliance.
- iv. This appliance is equipped with an ignition system that automatically lights the burner. Do not try to light the burner by hand.
- v. Rotate the manual oil shutoff valve to the "ON" position.
- vi. Turn on the electric power to the appliance.
- vii. Set the thermostat to the desired setting.
- viii. If the appliance will not operate, call your qualified service technician or oil supplier.

To Turn Off Oil to Appliance:

- i. Set the thermostat to the lowest setting and set the operating mode switch to "OFF".
- ii. If service is to be performed, turn off the electrical power to the appliance.
- iii. Turn the manual oil shutoff valve to the "OFF" position.

2. Adjustment of Burner Combustion:

⚠WARNING: Maximum gross stack temperature must not exceed 550°F (288°C) under any circumstances.

⚠CAUTION: Do not run the oil pump dry for more than five minutes, as irreparable damage may result.

NOTICE: Read the burner operation and service instructions, Model AFG Oil Burner Instruction Manual, before continuing.

To initially adjust and successfully service the oil burner in the appliance heating section, the following test instruments are required:

- A smoke density measuring and rating device,
- A carbon-dioxide (CO₂) or oxygen (O₂) analyzer,
- A flue gas temperature measuring device (e.g., thermocouple or thermister probe with readout device),
- An analog or digital multimeter, and
- An oil pressure gauge capable of reading 0-150 PSIG.

Adjust burner per burner instruction manual.

III. USERS INFORMATION SECTION

A. OIL SUPPLY: Do not allow the fuel tank to run completely empty. During the summer, keep the tank full to prevent condensation of moisture on the inside surface of the tank. If the fuel tank runs completely dry, it may be necessary to purge the lines of trapped air. Contact a qualified technician to bleed the lines and restart the burner.

OIL SUPPLY VALVE: Turn the oil supply valve off if the burner is shut down for an extended period of time.

B. COMBUSTION AIR SUPPLY: The burner requires a generous amount of clean combustion air to operate safely. Lack of adequate combustion air can result in erratic operation of the burner, noisy combustion, or fuel odors in the air. NEVER BLOCK THE FURNACE FROM THE SUPPLY OF COMBUSTION AIR. If there is an exhaust fan, dryer or return air grill in the furnace room, there should be increased concern and additional efforts may be required to provide adequate combustion oil to the furnace at all times.

C. INSPECTION AREAS

VESTIBULE: The furnace vestibule area or burner compartment should be inspected by removing the front door of the furnace and looking for signs of excessive heat such as discoloration of components materials damage, from rust or corrosion, soot or carbon build-up.

EXTERIOR OF FURNACE: The furnace exterior should be inspected for signs of excessive heat such as discoloration of materials and damage from rust or corrosion.

FLUE PIPE, VENT PIPE OR CONNECTOR: The furnace vent pipe should be inspected for signs of rust, corrosion pitting or holes in pipe, and leakage around seams in pipe, indicated by soot or condensate streaks.

CHIMNEY OR VENTING SYSTEM: The furnace venting system should be inspected for signs of rust, corrosion pitting or holes, and signs of condensation or moisture leakage from the venting system. If any of the above symptoms are evident, call a qualified heating contractor for assistance.

CAUTION: DO NOT ATTEMPT TO MAKE REPAIRS YOURSELF!

WARNING: The area around the furnace should be kept free and clear of combustible liquids and material, especially papers and rags.

WARNING: NEVER burn garbage or refuse in your furnace. Never try to ignite oil by tossing burning papers or other material into your furnace.

WARNING: Spirit oil furnaces are designed to burn No. 1 or No. 2 distillate fuel oil. Bio fuel blend up to 5% (B5) is permissible. NEVER USE GASOLINE OR A MIXTURE OF OIL AND GASOLINE.

CAUTION: DO NOT ATTEMPT TO START THE BURNER WHEN:

1. Excess oil has accumulated,
2. The furnace is full of vapors
3. The combustion chamber is very hot.

IF ONE OR MORE OF THESE CONDITIONS EXIST, CONTACT A QUALIFIED SERVICE PERSON.

D. STARTING THE BURNER:

1. Turn the main service switch to "OFF" position.
2. Set thermostat substantially above room temperature.
3. Open shut-off valves in oil supply line to burner.
4. Turn service switch to furnace "ON". If burner starts and runs, but stops again on lockout, it may be necessary to bleed the lines or make burner combustion air adjustments. Contact a qualified service person to adjust and start burner.

E. FILTER CLEANING AND LOCATION:

WARNING: To avoid injury from moving parts, hot surfaces, or electrical shock, shut off the power to the furnace before removing any furnace access doors to service the air filters.

The air filters should be inspected each month and cleaned when dirty. Cleaning the air filters frequently may reduce airborne contaminants from entering the furnace and depositing in the furnace, duct system and home.

Filter maintenance procedure:

Shut off the electrical power to the unit. Open the access door. Slide the air filter out of the filter rack. Clean the filter by either vacuuming, rinsing with tap water, hosing, or dipping in an ordinary detergent solution. After cleaning and drying the filter, replace the completely dry filter in the rack. If the filter has a supporting mesh, the mesh side of the filter must be placed towards the furnace.

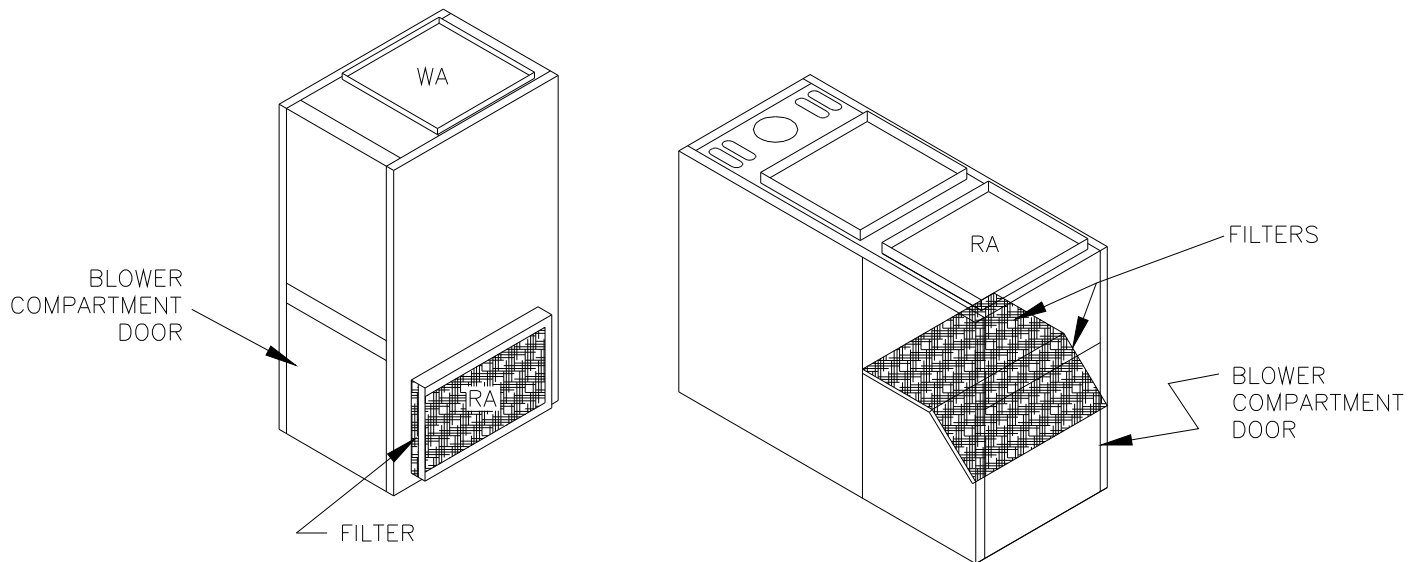

Fig 16: Filter Location for Typical Highboy & Lowboy Furnace

IV. DEALER MAINTENANCE:

SAFETY DURING SERVICING AND INSPECTION
<p>⚠WARNING: Personal injury or property damage could result from repair or service of this appliance by anyone other than a qualified heating contractor. The user may only perform the activities described in the Homeowner/User Routine Maintenance section of this manual.</p>
<p>⚠WARNING: To avoid injury from moving parts, or electrical shock, shut off the power to the appliance before removing blower compartment door and servicing this appliance.</p>
<p>⚠CAUTION: When servicing controls, label all wires prior to disconnecting. Reconnect any removed wires correctly. Wiring errors can cause improper and dangerous operation. Dangerous operation can result in injury or damage.</p>
<p>IMPORTANT: Verify the proper operation of this appliance after any servicing is performed.</p>

A qualified heating contractor should perform the following maintenance procedures at the beginning of each heating season. Correct any deficiencies at once.

A. HEAT EXCHANGER CLEANING INSTRUCTIONS:

WARNING: THE HEAT EXCHANGER MUST BE CLEANED BY A QUALIFIED SERVICE PERSON.

It is important to inspect and clean the heat exchanger once a year, or as necessary, to remove any build-up of soot. A layer of soot on the inside of the heat exchanger will act as an insulator and reduce heat transfer, resulting in less efficiency.

1. To clean the heat exchanger, first turn off all power to the unit. Remove clean-out plugs, the vent connector pipe to the chimney, the burner, and the burner mounting plates. When removing the clean-out plugs, remove the screw at the 12 o'clock position. Then, pull clean-out plug straight back.
2. With access to the inside of the heat exchanger through the burner area, clean-out openings, and vent pipe connection, it is possible to use a long, flexible wire brush and an industrial type vacuum cleaner to remove any soot build-up. **NOTE:** A one inch (outside diameter) vacuum cleaner hose will fit into the radiator.

To vacuum and brush the outer radiator of the heat exchanger, go through the clean-out openings in both directions, as shown in figure 18 on the next page.

3. Reassemble the furnace to its original construction*. Remount the burner being certain that the air tube is properly inserted into the chamber opening. If heavy soot deposits were found in the heat exchanger, this may indicate the burner is out of adjustment.

*When returning clean-out plugs to their original position, insert plug and replace screw at the 12 o'clock position. This is sufficient for sealing the access tube.

Replace any damaged or corroded components. All gaskets and insulation must be inspected, and replaced, if they show any signs of damage.

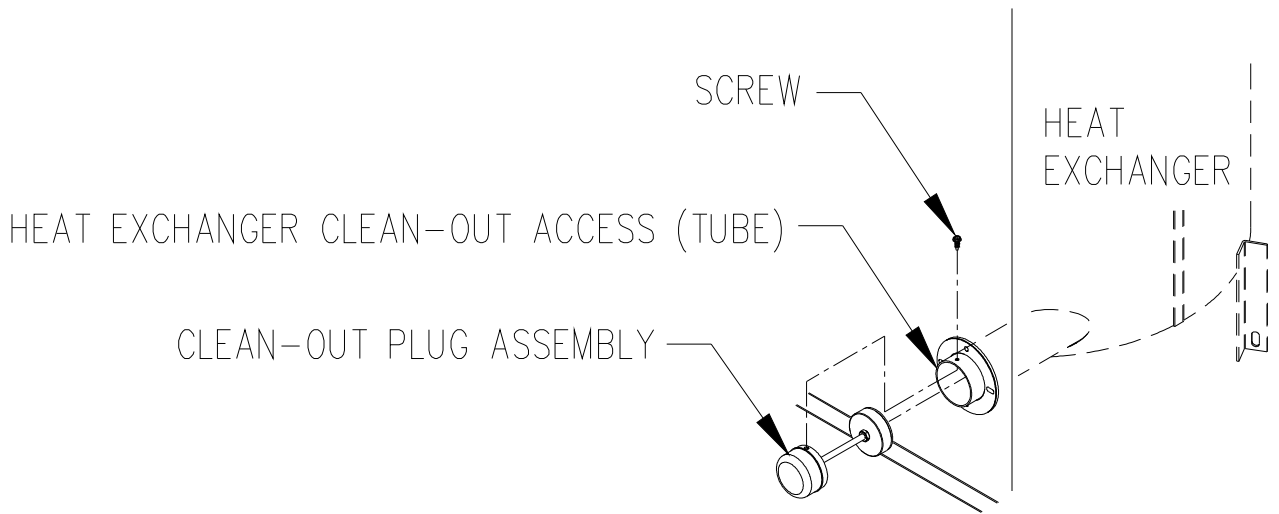
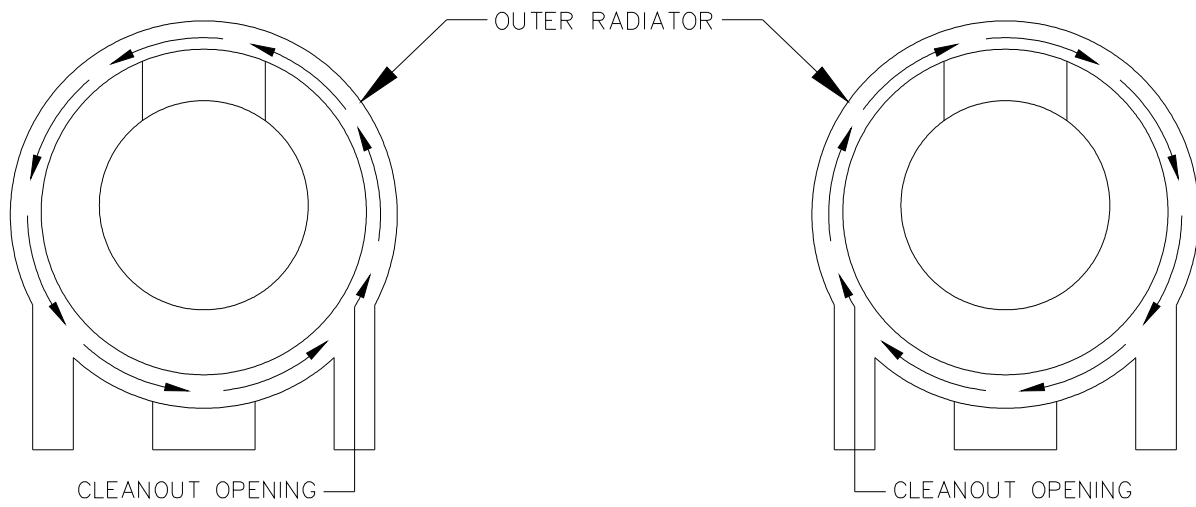

Figure 17: Heat Exchanger Clean-Outs



Vacuum Hose Length
 VH8F*, VL8F/R* 8FT

Fig. 18: Recommended method and device for cleaning inside of heat exchanger.

V. Sequence of Operations Flow Chart:

Mode of Operation

Standby
(At any time the oil valve is not energized)

Control System Action

Continous safe operation check. If flame simulation condition present, system shuts off oil valve,ignitor, and burner motor; activates fast flashing LED.

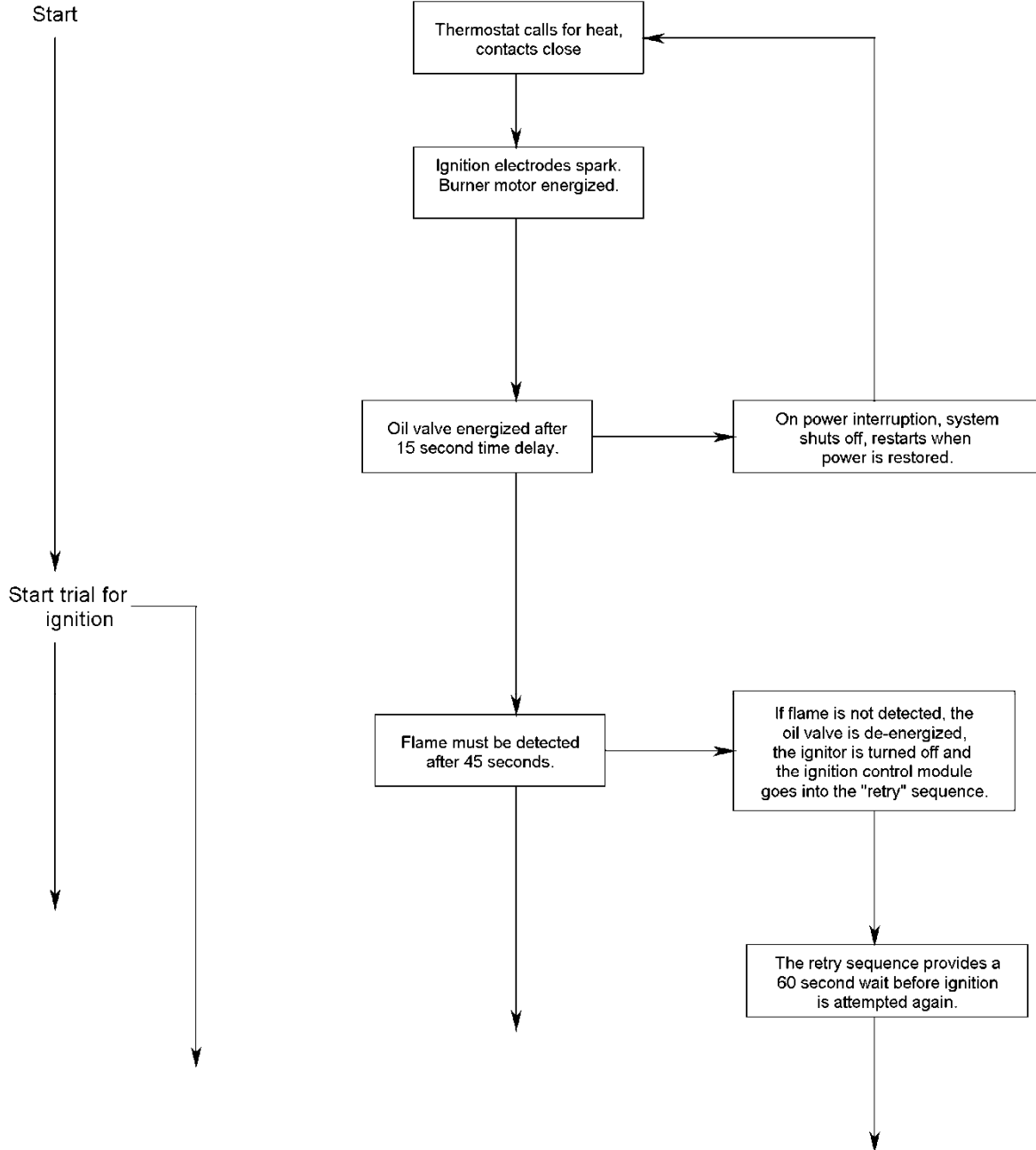

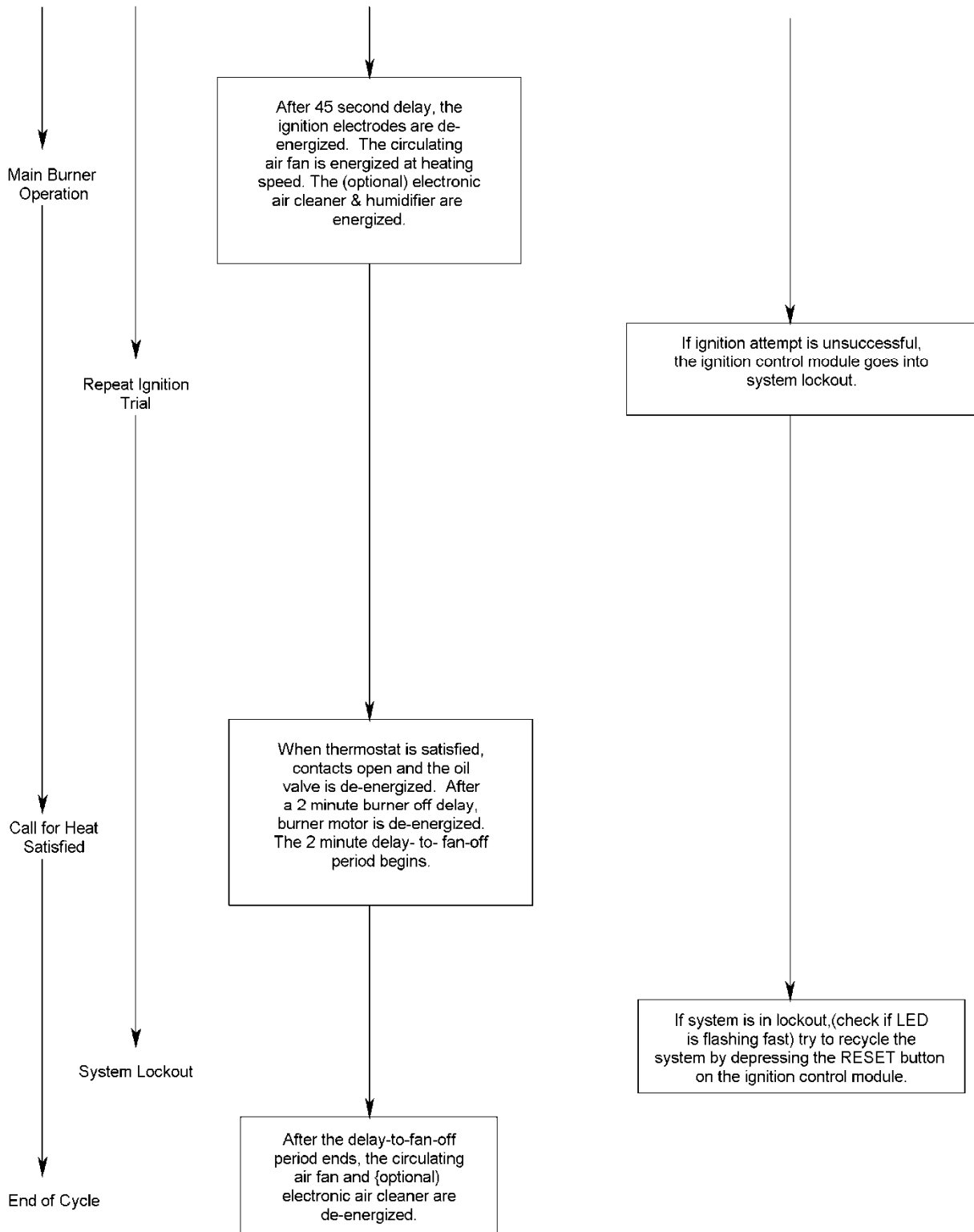

VI. Trouble Shooting Flow Chart:

Mode of Operation

Standby
(At any time the oil valve is not energized)

Control System Action

Continuous safe operation check. If flame simulation condition present, system shuts off oil valve, ignitor, and burner motor; activates fast flashing LED.

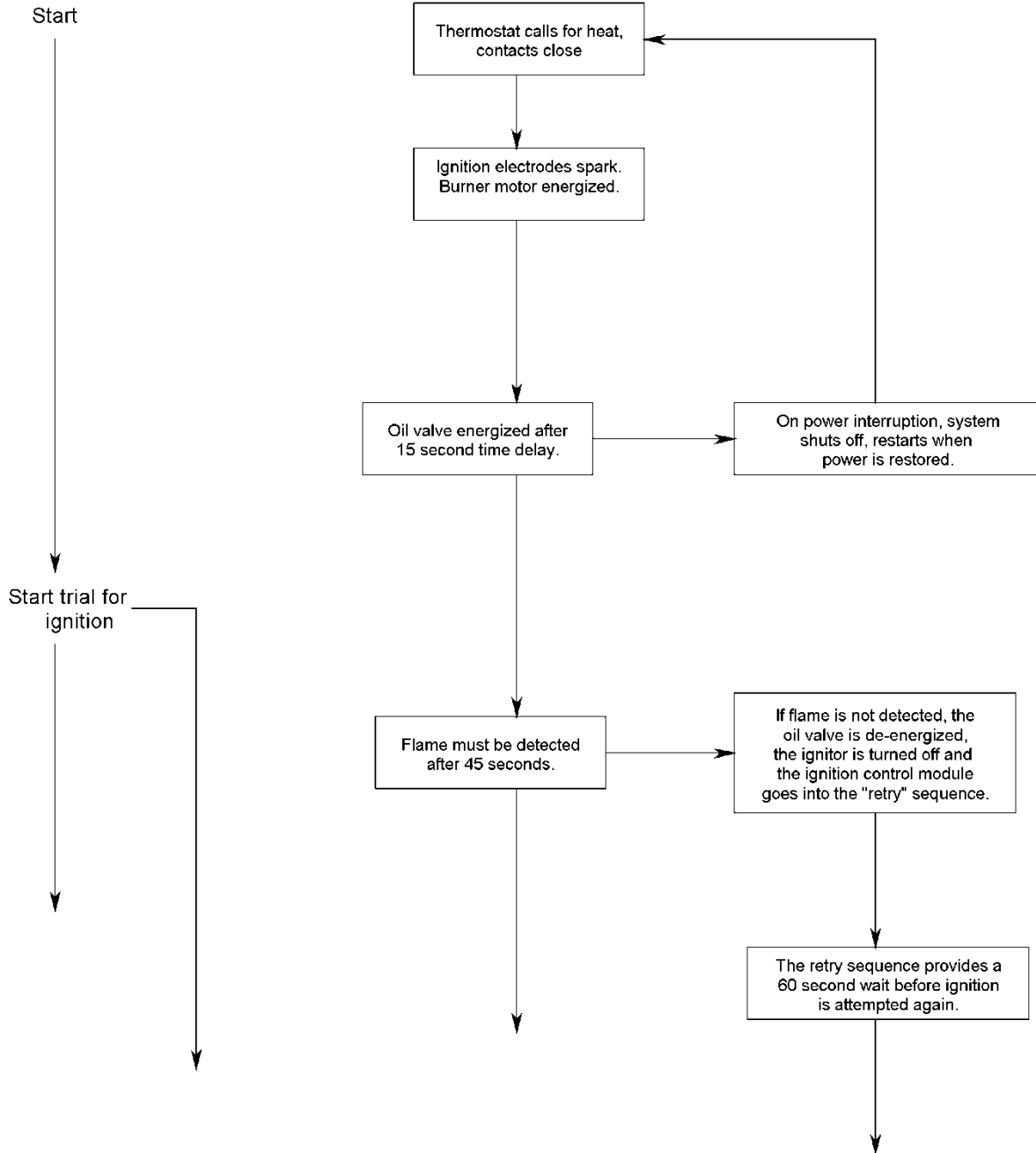

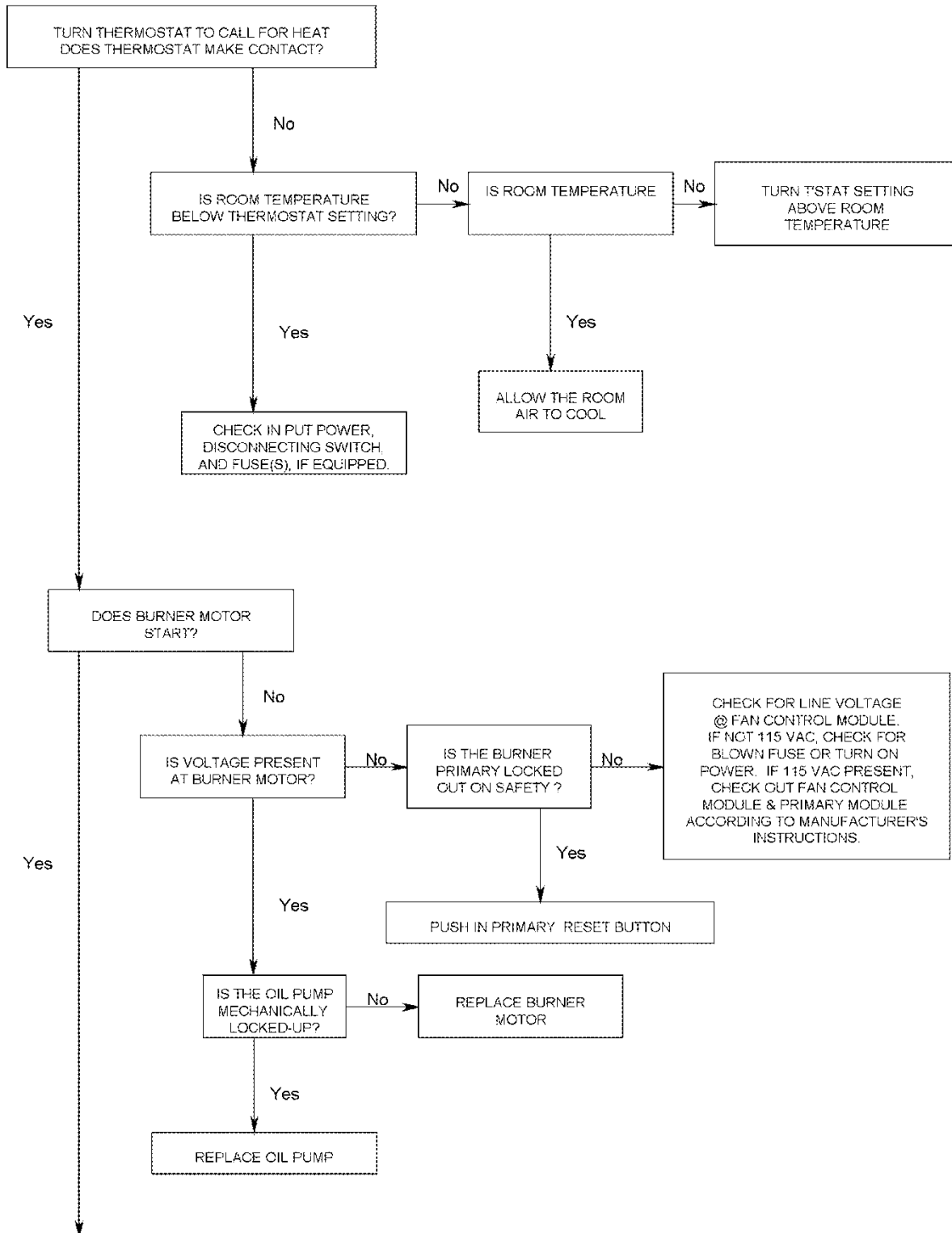

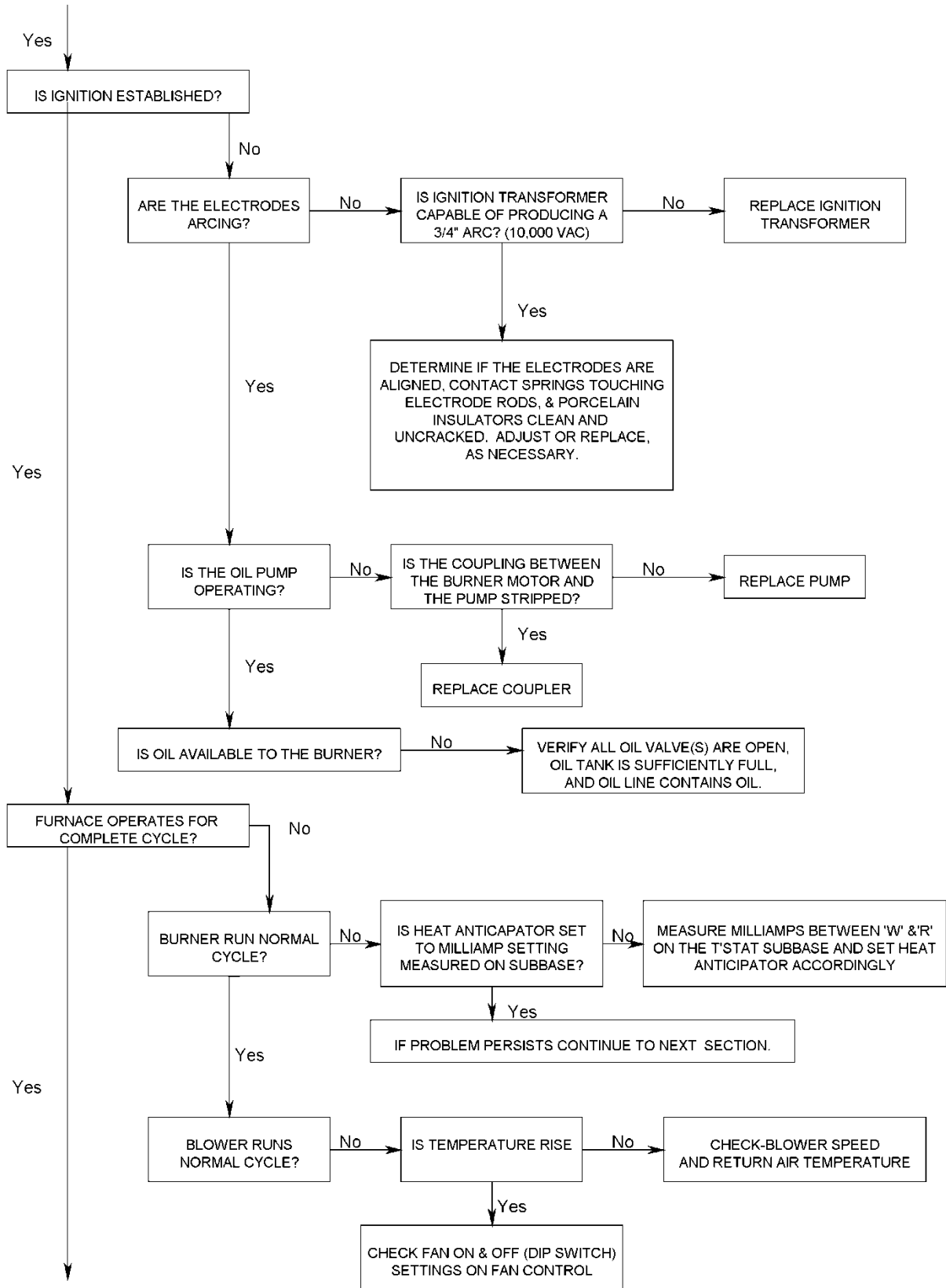

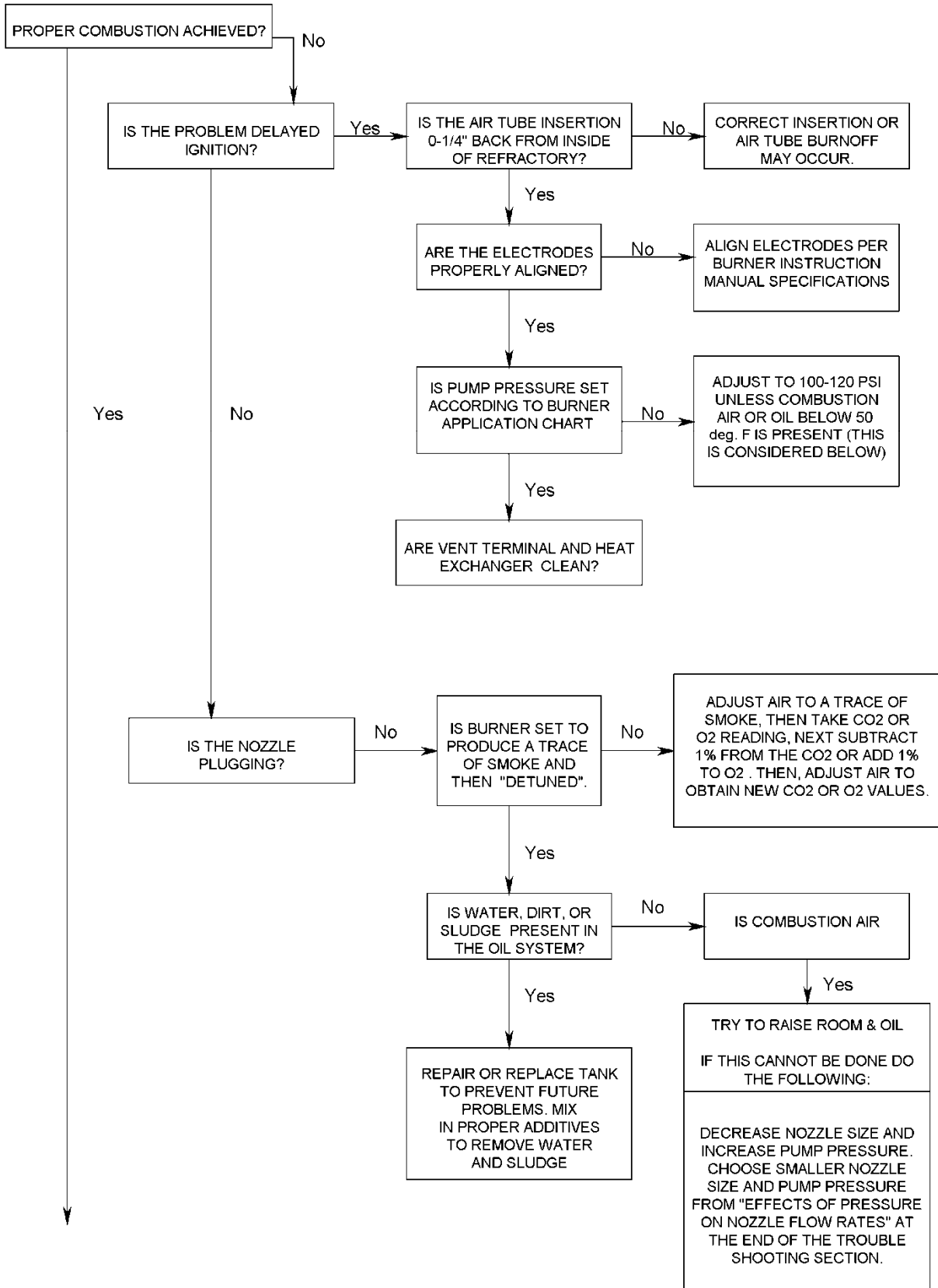

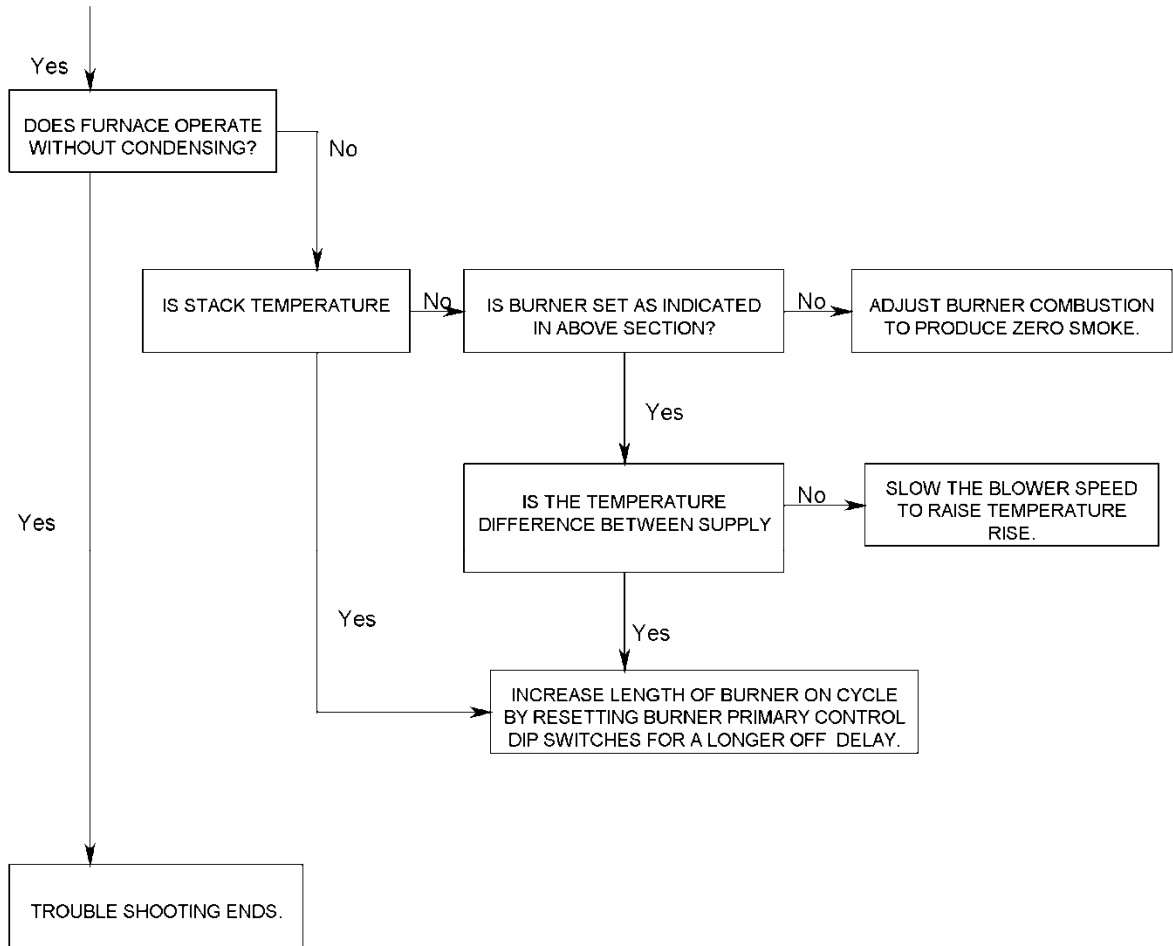

REPEAT PROCEDURE UNTIL TROUBLE FREE OPERATION IS OBTAINED.

COMBUSTION AND EFFICIENCY TESTING FOR OIL FIRED CENTRAL FURNACES.

Complete this form for each furnace installed. Read instruction manual carefully before making tests. Retain this form with furnace.

CUSTOMER	NAME				
	ADDRESS				
	CITY, STATE				
HEATING SYSTEM	BURNER MODEL NO.	BLAST TUBE LGTH.	AIR SHUTTER OPENING		
		INS.	% OF MAX. (EST)		
	COMBUSTION CHAMBER	CONDITION	MATERIAL	FURNACE MODEL	
	TYPE OF VENTING SYSTEM <input type="checkbox"/> MASONRY CHIMNEY <input type="checkbox"/> METAL CHIMNEY <input type="checkbox"/> SIDEWALL POWER VENTER <input type="checkbox"/> MASONRY CHIMNEY W/INDUCER <input type="checkbox"/> METAL CHIMNEY W/INDUCER <input type="checkbox"/> MASONRY CHIMNEY W/METAL LINER				
FUEL LINE FILTER	DRAFT CONTROL		FURNACE SERIAL NUMBER		
COMBUSTION TESTS (Operate burner at least 10 minutes before starting tests.)		INITIAL INSTALLATION	SERVICE	SERVICE	SERVICE
	CO2 in stack pipe				
	Draft Over-fire				
	Draft in stack pipe				
	Smoke number				
	Gross stack temp.				
	Furnace room temp.				
	Net stack temp. (Gross stack minus furnace room temp.)				
	Efficiency				
	Nozzle size and spray				
	Oil pump pressure				
	Operation of Controls				
	Burner Safety Controls				
	Check for oil leaks				
	Tests taken by				
	Date				
	NOTES:				
INSTALLER NAME & ADDRESS					