

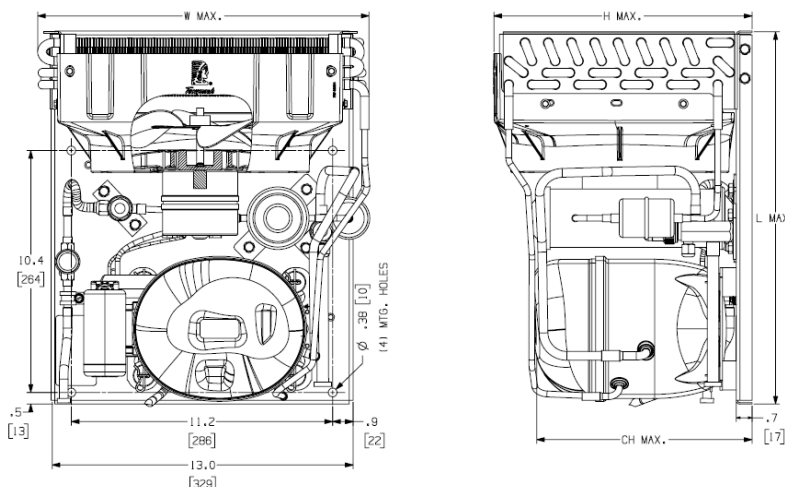

Celseon® Air Cooled Condensing Unit



Model: AE4450Z-AA1AD*
BoM: 2G225-** R-404A 1/2 HP



Model	Dimensions, inches				Line Connection*		Pumpdown	Air	Oil Ch	Gr. Wt.
	L	W	H	CH	Suction	Liquid	90 °F 90%	SCFM	Oz.	Lbs.
AE4450Z-AA1ADA	16.0	14.3	11.1	9.3	5/16" S	1/4" S	N/A	185	9.5	39
AE4450Z-AA1ADG					1/2" S	3/8" S	2.5 lbs			41
AE4450Z-AA1ADH					1/2" S	3/8" S	N/A			39
AE4450Z-AA1ADK					5/16" S	1/4" S	N/A			39
AE4450Z-AA1ADC					1/2" S	3/8" S	2.5 lbs			41
AE4450Z-AA1ADS					1/2" S	3/8" S	N/A			39
AE4450Z-AA1ADJ					1/2" S	3/8" S	2.5 lbs			41
AE4450Z-AA1ADP					1/2" S	3/8" S	2.5 lbs			41

* F = Flare, S = Solder, RF or RS = Rotolock with Flare or Solder Connections, C = Compression Fitting
Factory charge: 20 PSIG Nitrogen – **MUST BE EVACUATED**

Evaporator T,		Ambient Temperatures											
		80°F			90°F			100°F			110°F		
°F	PSIG	BTUH	Watts	Cond T	BTUH	Watts	Cond T	BTUH	Watts	Cond T	BTUH	Watts	Cond T
5	37.7	2828	549	100	2555	560	109	2281	571	118	2008	583	127
10	43.1	3110	579	102	2811	592	111	2511	604	120	2211	617	128
15	49.0	3404	610	104	3078	624	113	2751	638	122	2425	652	130
20	55.3	3709	641	107	3356	656	115	3003	672	124	2651	687	132
25	62.1	4026	672	109	3646	689	117	3267	706	126	2887	723	134
30	69.3	4353	704	111	3947	722	120	3541	740	128	3135	758	136
35	77.1	4692	735	114	4260	755	122	3827	775	130	3394	795	138
40	85.4	5043	768	116	4583	789	124	4124	810	132	3665	831	140
45	94.2	5404	800	119	4918	823	127	4432	845	134	3946	868	142
50	103.6	5777	833	122	5264	857	129	4752	881	137	---	---	---
55	113.6	6161	866	124	5622	891	132	5083	916	139	---	---	---

60 Hz Performance

Return gas temp 40°F below 20°F evaporator,
and 65°F above 20° evap, 5°F sub cooling

Electrical Diagram Page 3

