

# APOLLO

## 58A SERIES

FIXED ORIFICE, DOUBLE REGULATING AND COMMISSIONING VALVE

### GUIDE TO INSTALLATION, OPERATION AND MAINTENANCE

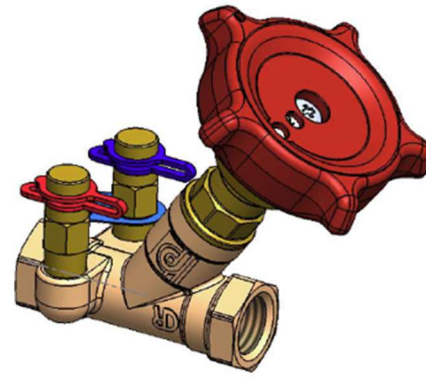

## 1. PRESSURE and TEMPERATURE RATING

CONNECTION	NON-SHOCK PRESSURE	MAXIMUM TEMPERATURE
Threaded, Solder and Press	300 CWP	250° F
Push	250 CWP	250° F

Valves can only be installed in a piping system with normal pressures and temperatures that do not exceed these indicated ratings.

The maximum allowable pressure in the valves, as specified in the standards, is for **non-shock** conditions. Water Hammer and Impact should be avoided.

If system testing will subject the valve to pressure in excess of the working pressure rating, this should be within the “shell test pressure” for the body, to a maximum of 1.5 times the pressure rating, carried out with the valve fully open.

It may be hazardous to use these valves outside their specified pressure and temperature limitations and also when not used for the correct application.

## 2. INSTALLATION

For ease of operation, adjustment, maintenance and repair, valve siting should be decided when the system is being designed. To prevent straining on the valve seat, pipework and valves must be adequately supported.

**These valves are not suitable for end of line service.**

Unpack valve and check **flow paths** and **end connections** are clean and free from debris.

Check **body markings** and **nameplate**, where fitted, to ensure the correct valve has been selected.

Check **pipework** to be connected to the valve is **free from debris** and other forms of contamination

Apollo 58A FODRV valves may be mounted in **vertical** or **horizontal** pipework.

**Flow Direction** is marked with an **arrow** on each body, the valve will only function correctly if the arrow matches up with the direction of flow in the pipework.

**Use suitable hangers** close to each end of the valve to avoid stresses transmitted by the pipe.

NOTE Severe damage can occur to stems, valves and seats by the use of hand wheels or levers larger than those originally supplied by the manufacturer, and by wheel keys

### THREADED Connections

Check **length of thread** on the connecting pipework. Excessive penetration of the pipe into the valve may cause damage or malfunction.

**Only apply jointing compound to the pipe threads** and not the valve, so any surplus will be forced outwards and not into the valve. Overuse of compound can be a factor in valve failure.

Threads should be engaged correctly when tightening the valve onto the pipe. The wrench should be fitted on the body end next to the joint being made.

### SOLDER, PRESS and PUSH Connections

Apollo 58A Series are available pre-assembled with Solder, Press and Push connections.

**Press fit** valves have **Apollopress™** direct connectors suitable for use with copper tube. The Joints are V press profile and have Leak before Press characteristics.

**Push fit** valves have **Apollopush™** direct connectors for connection to CPVC, Pex, and Copper pipe.

To create laminar flow and provide the clearest, most accurate signal for commissioning, a **straight length of pipework** equivalent to **5 x OD of the pipe**, should lead into the valve inlet.

A length of straight pipe is not required at the valve outlet.

Installation of the Apollo 58A FODRV should consider the position of the **Test Points** as well as the **Valve Control Handle**.

Sufficient space should be provided so that Manometer Probes can be connected to the test points, the Valve Control

handle can be operated without obstruction, and the Double Regulating mechanism can be set and operated easily.

Visibility of the Valve Control Handle settings would also be an advantage.

### 3. SELECTION and OPERATION

#### Valve Selection

Balancing valves should be selected based on a desired flow rate, not pipeline size. The table below shows the practical range of flow rates for each size of Apollo 58A Series FODRV.

Size		Min (GPM)	Max (GPM)
DN15	½"	0.84	1.83
DN20	¾"	2.17	3.31
DN25	1"	3.73	6.02
DN32	1¼"	6.13	12.5
DN40	1½"	9.41	18.7
DN50	2"	18.3	28.0

#### Preparing for Balancing

Before operating the system, all pipework must be thoroughly flushed to remove any remaining construction debris. Ensure the valve is **OPEN FULLY** during flushing.

To **OPEN** the valve, rotate the Control Handle **anticlockwise**. The display will increase but not reach **9 9**. To avoid seizing, when the handle reaches the upper end stop rotate clockwise approximately ½ a turn.

To **CLOSE** the valve, rotate the Control Handle **clockwise**. When the display reads **0 0** the valve should reach the seat and come to a stop at fully closed.

#### Setting a Flow - Using a Chart

1. Use CHART A to determine what **Pressure Drop corresponds to the Flow Rate** required
2. Unscrew the Caps on the Test Points and insert Manometer Probes with their corresponding colours. Ensure the Valve Control Handle is fully open. **Observe the Pressure Drop displayed**
3. Turn the Hand Wheel (close the Valve) until the desired Pressure Drop is displayed on the Manometer

#### Setting a Flow - Using Cvs Calculation

1. Connect a Manometer to the Test Points on the Valve. Observe the Pressure Drop displayed
2. Use the Manometer reading and the Cvs Value\* for the Valve with the following calculation to establish Flow Rate

3. Adjust the Control Handle and repeat the calculation with subsequent Pressure Drop values until the desired Flow Rate is achieved.

\*The Cvs value for the valve can be found on the Tag attached to the measuring point, or taken from the table below.

#### Flow Rate Calculation

$$GPM = Cvs \sqrt{\Delta P / SG}$$

GPM Flow Rate in Gallons Per Minute  
 Cvs Flow Coefficient  
 ΔP Differential Pressure in PSI  
 SG Specific Gravity of Fluid (Water = 1.0)

Model	Size	Cvs
58A203	½"	2.2
58A204	¾"	5.7
58A205	1"	9.8
58A206	1¼"	16.1
58A207	1½"	24.7
58A208	2"	48.0

#### NOTE

Greater flow setting accuracy can be achieved by using the calculation method in preference to the Look up Chart.

Using a digital manometer with a Cvs setting can speed up the setting process.

#### Setting the Maximum Flow Limit

To set the Maximum Flow Limit so the Valve Control Handle cannot exceed this setting in the future, remove the Cross-Head Screw from the centre of the handle. Insert a small, flat blade screwdriver into the aperture, engage the Setting Mechanism and rotate clockwise until it reaches a stop. Remove the screwdriver and replace the Handle Screw.

The Control Handle will now only operate between fully closed and this maximum flow setting.

**Caution:** Suitable hand protection should be worn when operating valves used in extreme temperature applications.

## CHART A

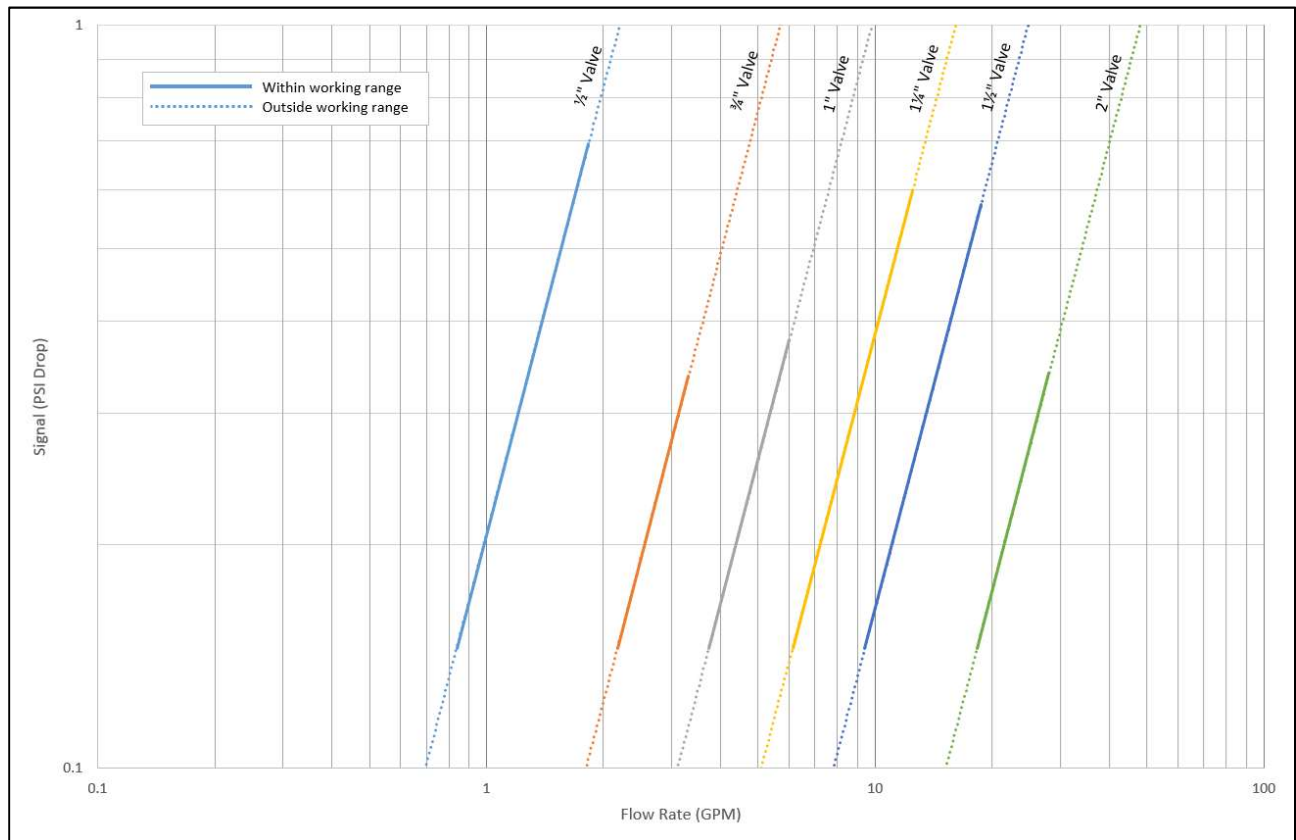

## 4. MAINTENANCE

Under normal working conditions Apollo 58A FODRV valves do not require any maintenance.

However, if the application calls for maintenance then a regular program is the most efficient method of ensuring longer-term operational efficiency of the selected valve.

Such a program would need to include a risk assessment and a planned procedure of how the maintenance will be carried out. The possibility of operational limits being exceeded and the potential hazards ensuing must be considered as part of this assessment.

Any program must include visual checks of the valve's condition as well as rudimentary checks on its operation, looking for signs of undesirable conditions developing, which could lead to failure.

The valve should be at zero pressure and ambient temperature before any valve maintenance is carried out.

The correct fitting tools and equipment should be used for valve maintenance work.

Separate means of draining the pipe work must be provided when carrying out any maintenance.

Where there may be system debris this should be collected and / or filtered by installation of the appropriate protective device.

## 5. PRODUCT LIFE

When a valve is properly selected for its service conditions it should give years of trouble-free service provided it is installed correctly and receives adequate preventative maintenance.

By not considering the compatibility of the system design and the pressure and temperature requirements the life

expectancy of the valves can be adversely affected and valve failure may occur.

The nature of the fluid being carried through the valve could also affect the valve performance and lead to premature valve failure. There may also be interactions between metals in the pipe system and the valve which need to be considered.

Appropriate flushing and cleaning of the pipework should take place when commissioning the system to maximise valve life.

It is strongly recommended to consult a commissioning engineer in conjunction with the manufacturer prior to their use.

## **6. STORAGE**

---

Valves should be stored off the ground in a clean, dry, indoor area. Where desiccant bags are included these should be changed after a period of six months.

Apollo valves are supplied in appropriate packaging to give adequate protection from damage and include end protection caps.