

Limited Warranty

This product comes with a two (2) year limited warranty on parts. The warranty provides that a replacement will be furnished for any part of the product that fails in normal use and service during the applicable warranty period specified, in accordance with the warranty's terms. The replacement part is warranted for only the unexpired portion of the original warranty.

All parts are warranted for a period of TWO (2) YEARS after the effective date. The effective date is the date of installation if properly documented. Otherwise, it is the date of manufacture plus twenty four (24) months.

STANDARD PROVISIONS AND CONDITIONS

The following terms are common to all of PROSTOCK'S individual product warranties.

THIS WARRANTY WILL NOT APPLY: a) to defects or malfunctions resulting from failure to properly install, operate or maintain the unit in accordance with the manufacturer's printed instructions; b) to damage from abuse, accident, fire, flood, and the like; c) to parts used in connection with normal maintenance, such as cleaning or replacing air filters; d) to units that are not installed in the United States of America or Canada; e) to units that are not installed in accordance with applicable local codes, ordinances and good trade practices; or f) to defects or damage caused by the use of any attachment, accessory or component not authorized by PROSTOCK.

SHIPPING COSTS: You will be responsible for the cost of shipping warranty replacement parts from our factory to our PROSTOCK distributor and from the distributor to the location of your product. You also are responsible for any shipping cost of returning the failed part to the distributor. (If in Alaska, Hawaii, or Canada, you also must pay the shipping cost of returning the failed part to the port of entry into the continental U.S.)

SERVICE LABOR RESPONSIBILITY: This Warranty does not cover any labor expenses for service, nor for removing or reinstalling parts. All such expenses are your responsibility, unless a service labor agreement exists between you and your contractor.

HOW TO OBTAIN WARRANTY PERFORMANCE: You must promptly report any failure covered by this warranty to the installing contractor or distributor. Normally, the installing contractor from whom the unit was purchased will be able to take the necessary corrective action by obtaining through his PROSTOCK distributor any replacement parts. If the contractor is not available, simply contact any other local contractor handling PROSTOCK products.

The name and location of a local contractor can usually be found in your telephone directory or by contacting a PROSTOCK distributor. If necessary, the following PROSTOCK office can advise you of the nearest PROSTOCK distributor:

P.O. Box 17010 • Fort Smith, Arkansas 72917-7010 • (479) 648-4786 • (For CA only: (866) 251-4090)

HOWEVER, ANY REPLACEMENTS ARE MADE SUBJECT TO VALIDATION BY PROSTOCK OF IN-WARRANTY COVERAGE.

An item to be replaced must be made available in exchange for the replacement.

MISCELLANEOUS: No one is authorized to make any warranties on behalf of PROSTOCK. ANY IMPLIED WARRANTIES, INCLUDING MERCHANTABILITY OR FITNESS FOR A PARTICULAR PURPOSE, SHALL NOT EXTEND BEYOND THE APPLICABLE WARRANTY PERIODS SPECIFIED ABOVE, PROSTOCK SOLE LIABILITY WITH RESPECT TO DEFECTIVE PARTS SHALL BE AS SET FORTH IN THIS WARRANTY, AND ANY CLAIMS FOR INCIDENTAL OR CONSEQUENTIAL DAMAGES ARE EXPRESSLY EXCLUDED. Some states do not allow limitations on how long an implied warranty lasts, or for the exclusion of incidental or consequential damages, so the above limitation or exclusion may not apply to you.

This Warranty gives you specific legal rights, and you may also have other rights that vary from state to state.



P.O. Box 17010 • 3900 South Zero Street • Fort Smith, Arkansas 72917-7010
Phone: (479) 648-4786 (For CA only: (866) 251-4090)



Duct Mount Media Air Cleaner

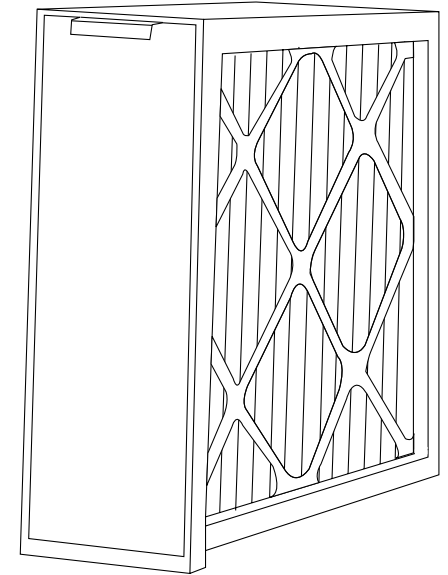

Installation • Operation • Maintenance

84-25050-01	2000 CFM	20" x 25"
84-25050-05	1400 CFM	20" x 20"
84-25050-06	1400 CFM	16" x 25"

CAUTION:
READ INSTALLATION, OPERATION, AND MAINTENANCE INSTRUCTIONS CAREFULLY FOR SAFE OPERATION.

How to Maintain Your Air Cleaner

The media filter cartridge in your air cleaner must be replaced periodically. The frequency of filter replacement is best determined by visual examination. On average, filter cartridges should be replaced every 9-12 months with normal usage.

STEPS FOR REPLACING FILTER CARTRIDGE

1. Open access door by pulling the handle. Remove door completely.
2. Pull used filter straight out of cabinet and place to side.
3. Remove new filter cartridge from plastic bag and save the bag.
4. Slide new filter cartridge into cabinet with "AIR-FLOW" arrow pointing in the direction of airflow.
5. Replace door and place used filter in plastic bag for easy disposal.

Replacement Filter Cartridges For Your Media Air Cleaner

Remember, periodic inspection and replacement of your filter will ensure high efficiency air cleaning. Contact your HVAC dealer for replacement filter cartridges.

Air Cleaner Part No.	Model (CFM)	Filter Cartridge Size	Replacement Filter Cartridge Part Number	Vendor Number	Number Per Carton
84-25050-05	1400	5 x 19 3/4" x 20 3/4"	54-25051-03	252990-103	4
84-25050-06	1400	5 x 15 3/4" x 24 1/4"	54-25051-04	252990-105	3
84-25050-01	2000	5 x 19 3/4" x 24 1/4"	54-25051-01	252990-102	3

Introduction

Your media air cleaner is a high efficiency air filtration device designed to remove dirt, dust, pollen and other microscopic particles from the air passing through it. Considering the messy dirt collecting job it performs, you will be pleased with the simplicity of its operation and care.

How the Air Cleaner Works

Dirty air enters the air cleaner by way of the return air duct system in your home. Particles are collected by the special pleated filter media. The pleats provide an exceptionally large filtering face area in a very compact space which allows maximum dirt holding capacities with minimum air flow resistance.

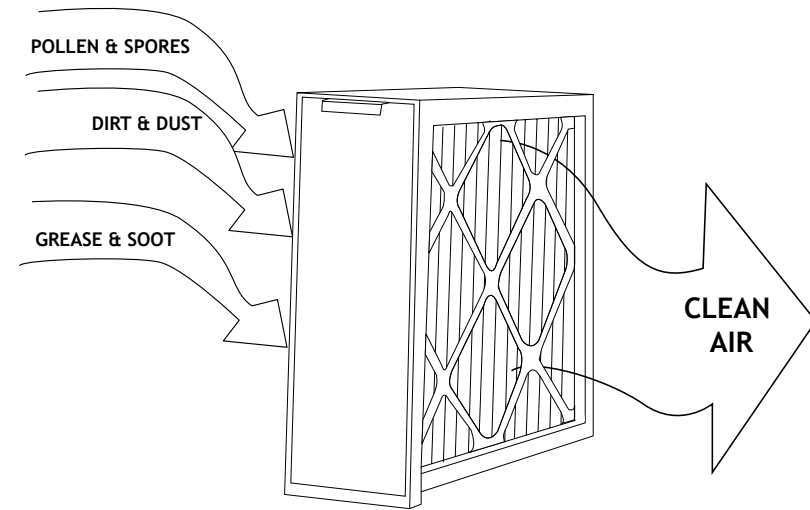

Unit Diagram

- 2000 CFM (20" x 25" x 5") 84-25050-01
- 1400 CFM (16" x 25" x 5") 84-25050-06
- 1400 CFM (20" x 20" x 5") 84-25050-05

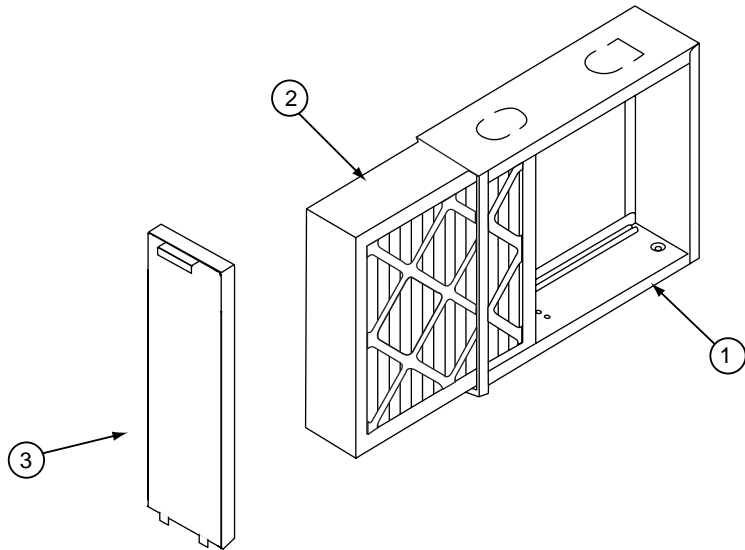

1. Cabinet
2. Filter Cartridge
3. Access Door

Capacity Selection Guide

Part Number	84-25050-05	84-25050-06	84-25050-01
Model	1400 CFM (20" x 20")	1400 CFM (16" x 25")	2000 CFM (20" x 25")
Air flow (CFM)	Resistance (Inches W.G.)		
600	.04	.04	.03
800	.08	.08	.05
1000	.12	.12	.07
1200	.18	.18	.10
1400	.24	.24	.14
1600	.	.	.18
1800	.	.	.22
2000	.	.	.27

Installation

Physical Installation

The air cleaner can be installed in any position, except with the access door facing down. The section entitled **Typical Mounting Positions** shows examples of proper air cleaner mounting with a variety of furnace installations.

Prior to installing this product . . .

1. Read rules and instructions carefully for safe operation. Failure to follow them could damage the product or cause a hazardous condition.
2. Check the ratings given on the product to make sure it is suitable for your application.
3. Remove the old furnace filter and discard.
4. The air cleaner cannot remove existing dirt from the blower and ducts. Clean the area thoroughly before beginning installation.

NOTE:

The following is a typical installation of the air cleaner on a highboy furnace. You may have to alter the installation to fit your specific application.

5. Locate the cabinet in the cold air return duct such that all of the return air flows through the unit. If the furnace and air cleaner openings are different, use a transition.
6. Mounting holes are provided in the air cleaner cabinet for ductwork attachment. The .140" diameter holes are sized for #8 sheet metal screws, or 1/8" rivets. If the adjoining ductwork is flanged, install the screws with the screw heads inside the cabinet, to prevent damage to the filter cartridge during removal and installation.
7. Remove the plastic bag from the filter cartridge and replace filter cartridge in cabinet.
8. After the unit has been secured, seal seams air tight with duct tape or caulking. Reinstall access door to ensure a tight seal.

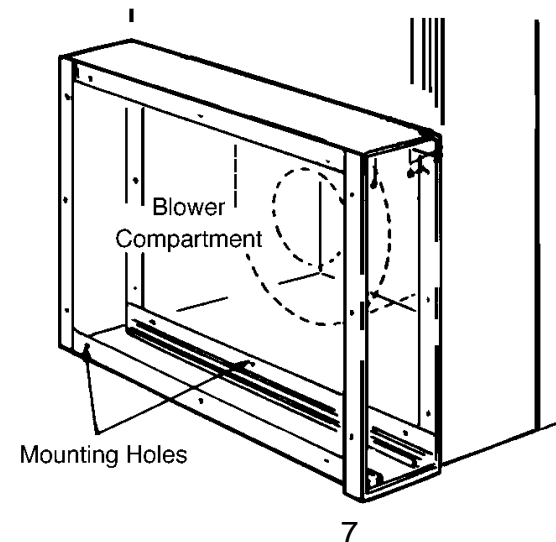

Installation

Turning Vanes

If the air cleaner is installed adjacent to a 90° duct elbow, add turning vanes inside the duct to improve the air distribution across the face of the air cleaner.

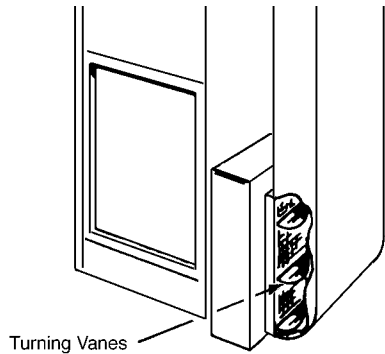

Direction of Air Flow Through the Air Cleaner

The air cleaner is set up for left to right air flow, when facing the access door. For right to left air flow remove filter cartridge, turn it around and replace in cabinet. The directional arrows on the filter cartridge must point in the direction of air flow.

Humidifiers

Location of the system humidifier is important to the operation of the air cleaner. When an evaporative type humidifier is used, it may be installed between the furnace warm air duct and the return air duct without effecting the air cleaner. Atomizing and spray type humidifiers should be installed downstream of the air cleaner. If the humidifier must be installed upstream of the furnace, allow at least 6' between the air cleaner and humidifier.

Dimensions

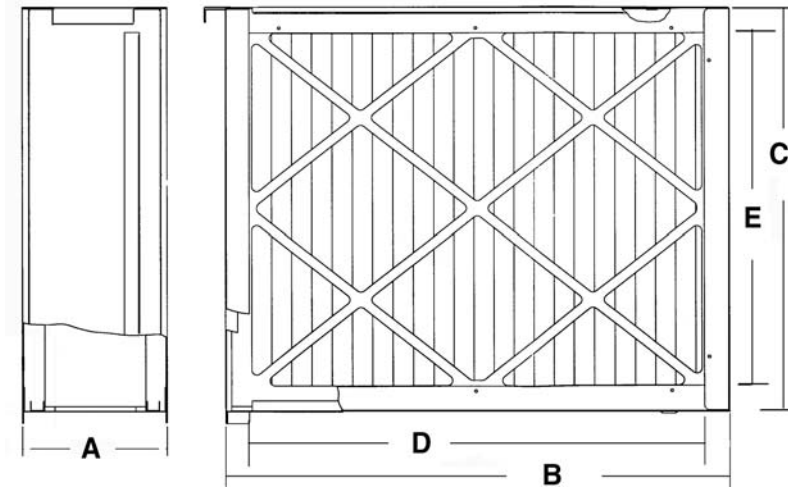

Part Number	84-25050-05	84-25050-06	84-25050-01
Model	1400 CFM	1400 CFM	2000 CFM
Filter Cartridge	20" x 20" x 5"	16" x 25" x 5"	20" x 25" x 5"
Air Flow (CFM)	600-1400	600-1400	600-2000
Dimensions			
A	7 1/8" (181mm)	7 1/8" (181mm)	7 1/8" (181mm)
B	21 3/8" (543mm)	24 7/8" (632mm)	24 7/8" (632mm)
C	20 1/4" (514mm)	16 1/4" (413mm)	20 1/4" (514mm)
Duct Opening			
D	19" (483mm)	22 1/2" (572mm)	22 1/2" (572mm)
E	17 7/8" (454mm)	13 7/8" (352mm)	17 7/8" (454mm)
Filter Cartridge Replacement	9-12 months between changes UL class 2		

TYPICAL MOUNTING POSITIONS

(Shaded illustrations are for positioning use only.)

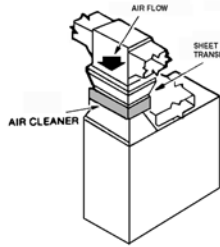

Basement Furnace (Lowboy) - Mounted horizontally in return plenum- just above the furnace.

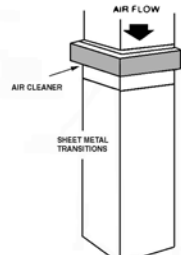

Counterflow Furnace- Mounted horizontally in return duct- just above the furnace.

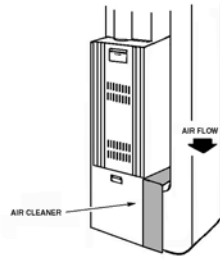

Space Saver Furnace (Highboy)- Side installation. Mounted vertically, where return air enters side inlet of furnace.

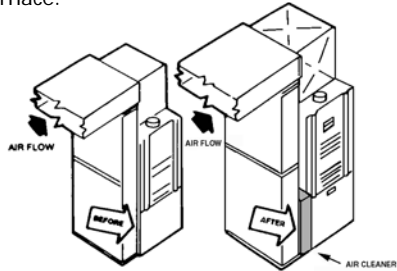

Offset Installation- If there is less than 7-in. for mounting the air cleaner between the duct and the furnace, move the return air drop.

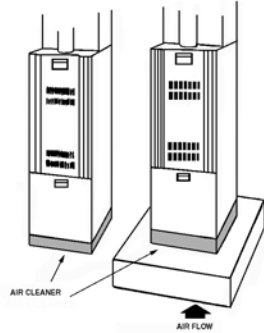

Space Saver (Highboy)- Installation beneath furnace. Cleaner mounts horizontally, where return air enters from below. Raise furnace by installing a suitable wood structure and install air cleaner.

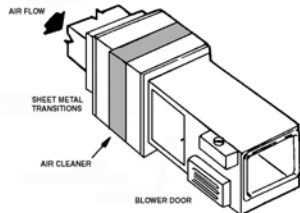

Horizontal Furnace- Mounted vertically in return duct as close to the furnace as possible.

Application

This air cleaner is used in forced air heating, cooling, and ventilating systems. The air cleaner should be installed in the system such that all the system air is circulated through the air cleaner. The air cleaner will only remove the airborne contaminants delivered to it; therefore maximum performance is obtained with the system blower set for continuous operation.

Installation Requirements

The best location for the air cleaner is in the return air duct next to the blower compartment. In this location, the blower motor and cooling coils will be kept clean. Do not install the air cleaner in the discharge air duct. Before installing the air cleaner, consider the application. If a transition between the ductwork and air cleaner is required, refer to section entitled **Transitions**. The unit must be readily accessible for periodic inspection and replacement of the filter cartridge to maintain maximum efficiency and trouble-free operation. Allow a minimum of 26" clearance in front of the access panel for filter cartridge replacement.

Air Conditioning

The air cleaner should be installed upstream of the cooling coil to keep the coil clean and reduce air conditioning coil maintenance. A clean coil will reduce utility costs by maintaining the coil's efficiency. Failure to replace filter cartridge can cause damage to the cooling system.

Transitions

If the air duct does not fit the air cleaner cabinet opening, gradual transitions are recommended to reduce air turbulence through the air cleaner and maximize efficiency. Not more than 20° (about 4" per running foot) of expansion should be used on each side of the transition fitting.

