

# spirax sarco

TI-P076-10  
 ST Issue 6

## SMC32 and SMC32Y Carbon Steel Bimetallic Steam Traps

### Description

The SMC32 and SMC32Y are carbon steel maintainable bimetallic steam traps with straight connections. The SMC32 has an integral flat strainer screen and the SMC32Y an integral, cylindrical Y-type strainer. All pressure bearing components are produced by TÜV approved suppliers in accordance with AD-Merkblatt WO/TRD 100.

### Standards

This product fully complies with the requirements of the European Pressure Equipment Directive 97/23/EC.

### Certification

This product is available with certification to EN 1024 3.1.  
**Note:** All certification/inspection requirements must be stated at the time of order placement.

### Sizes and pipe connections

½", ¾", and 1" screwed BSP or NPT.  
 ½", ¾", and 1" socket weld ends to BS 3799.  
 ½", ¾", and 1" butt weld ends to EN 12 627.  
 DN15, DN20 and DN25 standard flange to EN 1092 PN40,  
 ASME B 16.5 Class 150 and 300, JIS/KS 10K and JIS/KS 20 K.

### Pressure/temperature limits (ISO 6552)

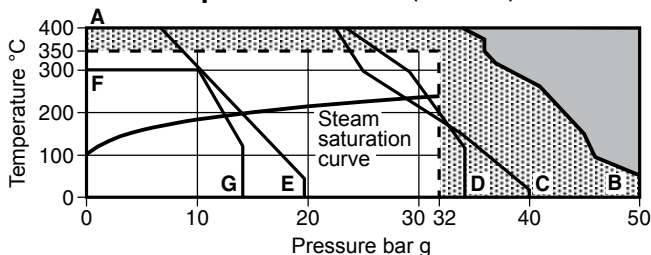

■ The product must not be used in this region.  
 ▨ The product should not be used in this region or beyond its operating range as damage to the internals may occur.

- A - B Screwed, socket weld, butt weld and flanged ASME 300.
- A - C Flanged EN 1092 PN40.
- A - D Flanged JIS/KS 20K.
- A - E Flanged ASME 150.
- F - G Flanged JIS/KS 10K.

Body design conditions	PN40
PMA Maximum allowable pressure	50 bar g @ 50°C
TMA Maximum allowable temperature	400°C @ 35 bar g
Minimum allowable temperature	-60°C
PMO Maximum operating pressure for saturated steam service	32 bar g
TMO Maximum operating temperature	350°C @ 32 bar g
Minimum operating temperature	0°C
<b>Note:</b> For lower operating temperatures consult Spirax Sarco	
Designed for a maximum cold hydraulic test pressure of 75 bar g	

### SMC32

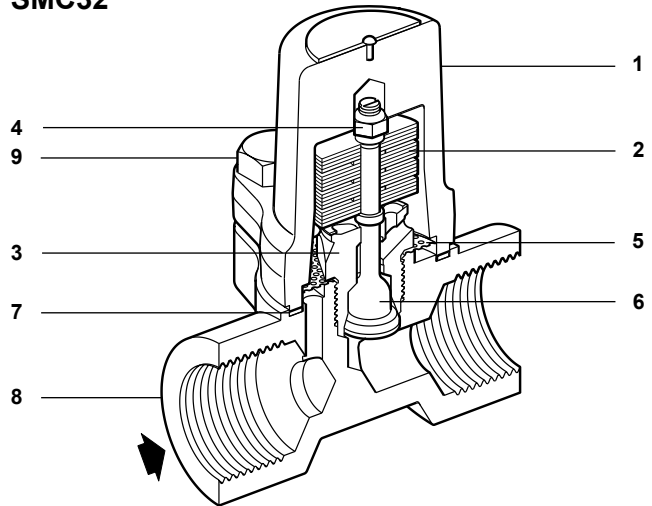

### SMC32Y

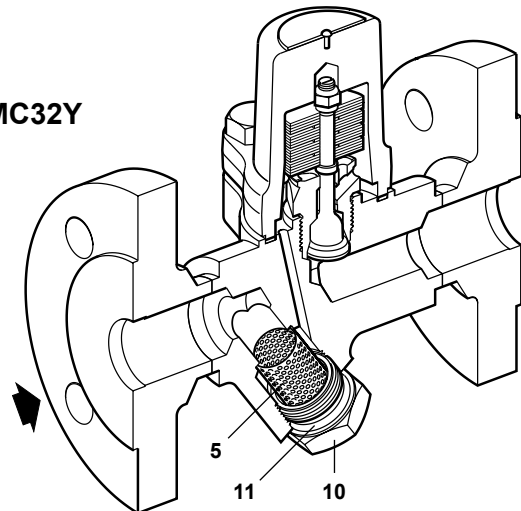

### Materials

No.	Part	Material
1	Cover	Carbon steel (W/S 1.0460) DIN 17243 C22.8 ASTM A105N
2	Bimetallic element	Corrosion resistant bimetal and stainless steel Rau Type H46
3	Valve seat	Stainless steel BS 970 431 S29
4	Locking nut	Stainless steel
5	Strainer screen	Stainless steel AIS 304
6	Valve	Stainless steel
7	Cover gasket	Stainless steel reinforced exfoliated graphite
8	Body/flanges	Carbon steel (W/S 1.0460) DIN 17243 C22.8 ASTM A105N
9	Cover bolts	Stainless steel (M10 x 30) A2 70
10	Strainer cap	Carbon steel (W/S 1.0460) DIN 17243 C22.8 ASTM A105N
11	Strainer cap gasket	Stainless steel BS 1449 304 S16

**Dimensions / weights (approximate) in mm and kg**  
**SMC32**

Size	A	A1	B	C	D	E	F	G	Weight	
									Scrd/SW/BW	Flgd
½" DN15	95	150	94	92	17	51	-	-	1.7	3.1
¾" DN20	95	150	94	92	19	51	-	-	1.7	3.7
1" DN25	95	160	94	92	23	51	-	-	1.8	4.4

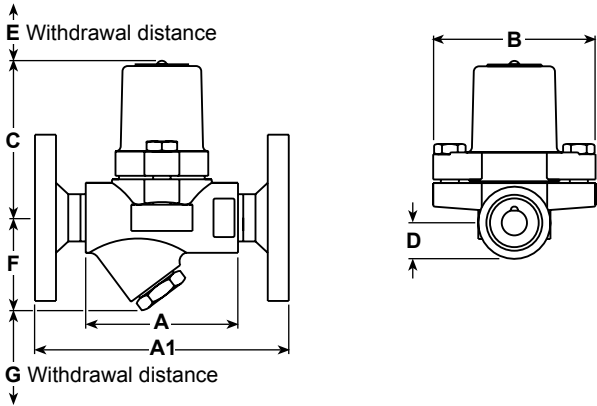

**SMC32Y**

Size	A	A1	B	C	D	E	F	G	Weight	
									Scrd/SW/BW	Flgd
½" DN15	95	150	94	92	-	51	54	28	1.7	3.1
¾" DN20	95	150	94	92	-	51	54	28	1.7	3.7
1" DN25	95	160	94	92	-	51	54	28	1.8	4.4

**Capacities**

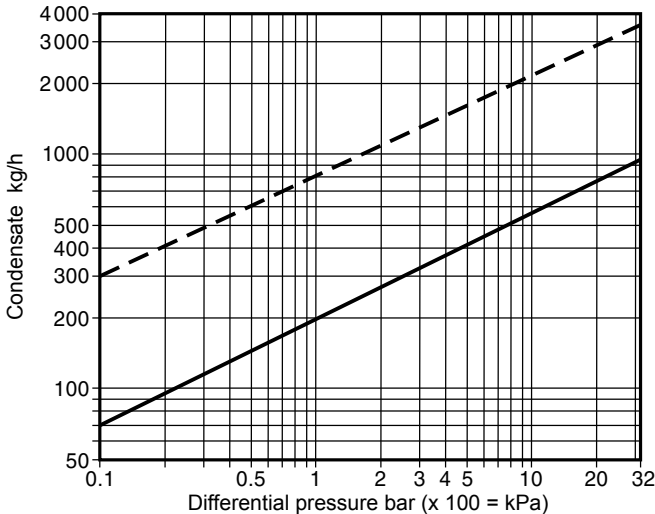

Hot water capacity ————— Cold water capacity - - - - -

**Safety information, installation and maintenance**

For full details see the Installation and Maintenance Instructions (IM-P076-09) supplied with the product.

**Installation note:**

The SMC32 and SMC32Y are designed for installation in any position, horizontal or vertical.

It is recommended that a non-return valve is fitted when discharging condensate into return lines where backpressure is experienced. It is also recommended that a diffuser is fitted when discharging to atmosphere.

Increased backpressure will reduce the temperature of condensate discharge. For further information consult Spirax Sarco.

For ease and maintenance, consideration should be given to fitting isolation valves upstream and downstream of the steam trap.

**Disposal**

These products are recyclable. No ecological hazard is anticipated with the disposal of these products, providing due care is taken.

**How to order**

**Example:** 1 off Spirax Sarco ½" SMC32 carbon steel bodied maintainable bimetallic steam trap with an integral strainer screen and screwed BSP connections.

**Spare parts**

The spare parts available are shown in solid outline. Parts drawn in broken line are not supplied as spares.

**Available spares**

Element set			<b>2, 3, 4, 6</b>
Strainer screen	SMC32	(3 off)	<b>5</b>
Strainer screen and gasket	SMC32Y	(1 off)	<b>5, 11</b>
Set of cover gaskets		(packet of 3)	<b>7</b>
Strainer cap gasket		(packet of 3)	<b>11</b>

**How to order spares**

Always order spares by using the description given in the column headed 'Available spares' and state the size and type of trap.

**Warning: Do not dismantle the element set by removing the locking nut (4) or the setting of the trap will be affected.**

**Example:** 1 - Element set for a Spirax Sarco ½" SMC32 bimetallic steam trap.

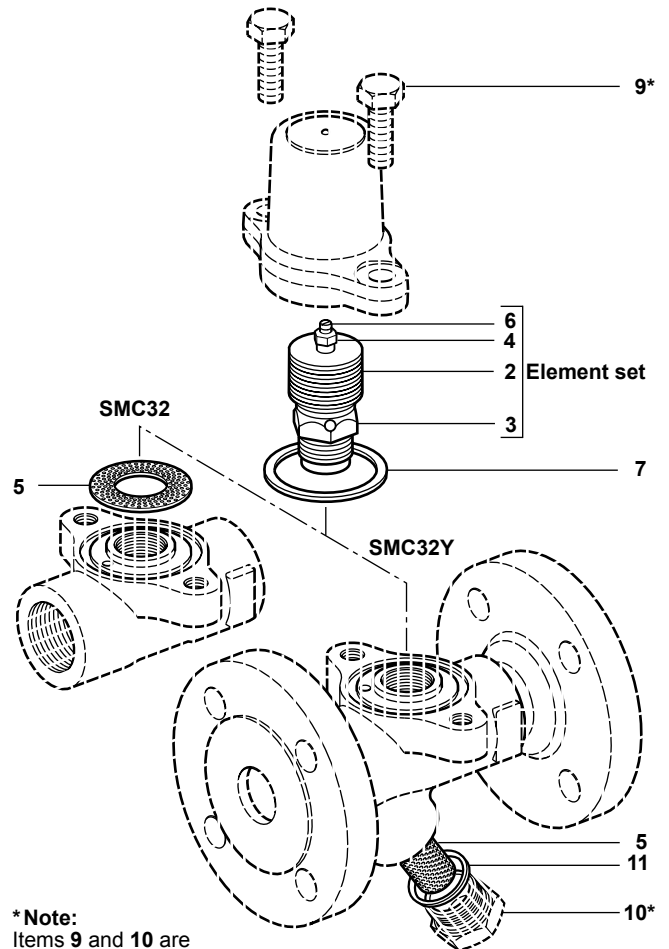

\* Note: Items 9 and 10 are not available as spares.

**Recommended tightening torques**

Item	Part	mm		N m
		or		
3	Valve seat	24 A/F		115 - 125
9	Cover bolts	16 A/F	10 x 30	23 - 27
10	Strainer cap	27 A/F		120 - 135