

in sink erator®

Evolution Series®

Grind More. Hear Less.®



Dimensions

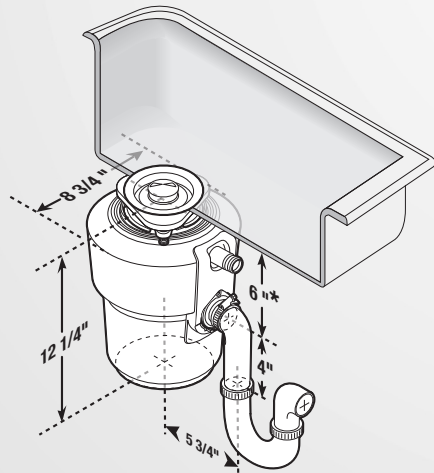

* Add 1/2" when stainless steel sinks are used.

Job Specifications

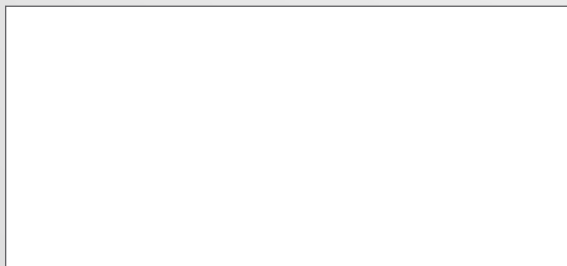

Food Waste Disposers

Evolution Essential® XTR

With SinkTop Switch™ Activation Included

Submittal Sheet

The ideal choice for a wide range of applications.

- **SoundSeal®** technology delivers quieter performance. Hold a conversation with elevated voices in the same room.
- **MultiGrind®** technology delivers 2 stages of grind vs. 1 stage in standard disposer.
- Includes Quiet Collar® sound reducing sink baffle.
- Includes SinkTop Switch accessory with Satin Nickel button and power cord for easy disposer activation.

Sample Specification

Food Waste Disposer(s) shall be InSinkErator Model Evolution Essential® XTR with MultiGrind® and SoundSeal® technologies, 3/4 HP motor, Stainless Steel Grind components, SinkTop Switch™ accessory and power cord accessory.

Warranty:

6-Year parts and in-home service.

* The complete InSinkErator warranty is included in the Care & Use Booklet packed with each unit.

Specifications

| | |
|-----------------------------|--|
| Type of Feed | Continuous |
| On/Off Control | SinkTop Switch™ |
| Motor | Single Phase |
| HP | 3/4 |
| Volts | 120 |
| HZ | 60 |
| RPM | 1725 |
| Amp. (Avg. Load) | 8.1 |
| Time Rating | Intermittent |
| Lubrication | Permanently Lubricated Upper & Lower Bearings |
| Shipping Weight (Approx.) | 20.0 lbs. |
| Unit Finish | Black Enamel Gray |
| Overall Height | 12-1/4" |
| SoundSeal Technology | Anti-Vibration Mount® Anti-Vibration Tailpipe Mount™ Quiet Collar® Sink Baffle SoundLimiter® Insulation |
| MultiGrind Technology | GrindShear Ring® |
| Grind Chamber Capacity | 34.6 oz. |
| Motor Protection | Manual Reset Overload |
| Average Water Usage | Approx. 1 Gallon Per Person Per Day |
| Average Electrical Usage | 3-4 KWh Per Year |
| Drain Connection | 1-1/2" Anti-Vibration (Hose Clamp) |
| Dishwasher Drain Connection | Yes |



Food waste disposers can provide an environmentally responsible alternative to transporting food waste to landfills. And they can help reduce greenhouse gas emissions. At capable wastewater treatment plants, food waste can be recycled to produce renewable energy. Additionally, capable wastewater treatment plants can process food waste into fertilizer. (Check the plant in your area.)

www.insinkerator.com/green



The mark of responsible forestry
BV-COC-080715
© 1996 Forest Stewardship Council A.C.



EMERSON™
Commercial & Residential Solutions

The Emerson logo is a trademark and service mark of Emerson Electric Co. The mounting collar configuration is a trademark of Emerson Electric Co.

InSinkErator may make improvements and/or changes in the specifications at any time, in its sole discretion, without notice or obligation and further reserves the right to change or discontinue models.

1-800-558-5700

www.insinkerator.com