

UPS 32-80/2, 3 ph, 208-230 V, 460 V, 575 V★, 60 Hz

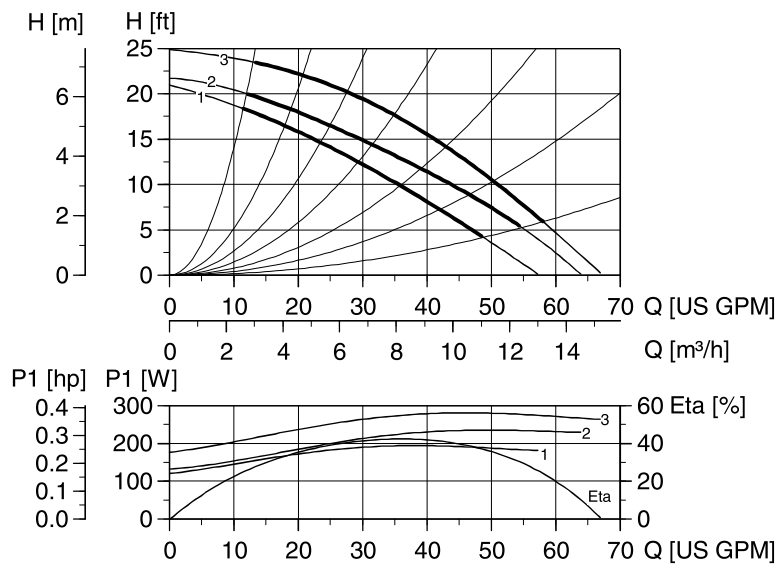

TM00 9494 0697

- Flow range: 9 - 67 gpm
- Head range: 1 - 25 ft
- Motor: 2-pole 0.50 Hp
- Max. liquid temp (Open): +140 °F
- Max. liquid temp.: +248 °F
- Min. liquid temp.: +32 °F
- Max. system pressure: 145 psi
- Net wt: 35.9 lbs (16.3 kg)
- Gross wt.: 41.1 lbs (20 kg)
- Shipping volume: 1.70 ft³ (0.048 m³)
- Net wt. bronze: 39.2 lbs (17.8 kg)
- Gross wt. bronze: 47.4 lbs (21.5 kg)
- Shipping volume bronze: 1.70 ft³ (0.048 m³)

Note: ETA is calculated as wire-to-water efficiency.

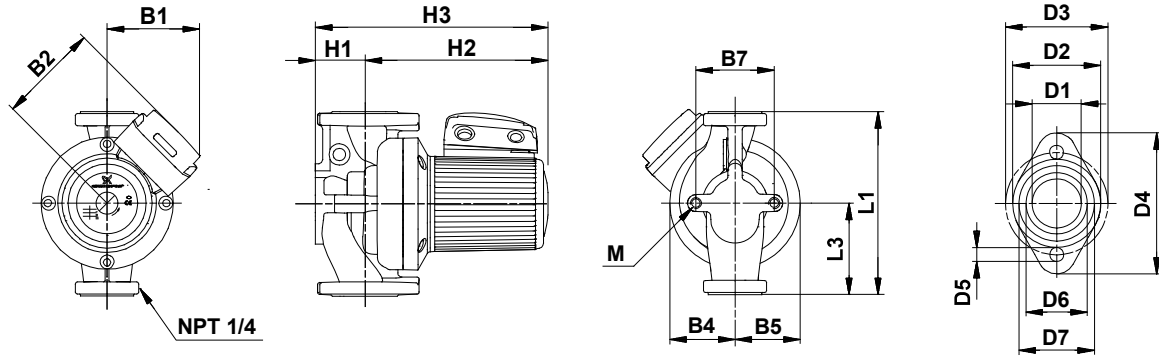

TM02 0729 5100

Dimensions

| Model | L1 | L3 | B1 | B2 | B4 | B5 | B7 | H1 | H2 | H3 | D1 | D2 | D3 | D4 | D5 | D6 | D7 | M |
|-------------|------|-------|------|------|------|------|------|------|------|------|-------|------|------|------|------|------|------|------|
| UPS 32-80/2 | [in] | 11.00 | 5.50 | 5.31 | 5.56 | 3.00 | 3.00 | 3.19 | 2.69 | 9.50 | 12.12 | 1.44 | 2.56 | 3.14 | 4.63 | 0.50 | 1.81 | 2.25 |
| | [mm] | 279 | 140 | 135 | 141 | 76 | 76 | 81 | 68 | 241 | 308 | 37 | 65 | 80 | 117 | 13 | 46 | 57 |

Product numbers

| Model type | Product number | | Voltage [V] |
|-----------------------|----------------|----------|-------------|
| | Cast Iron | Bronze | |
| UPS 32-80/2 (3 ph) | 96402710 | 96402715 | 208-230 |
| | 96402711 | 96402716 | 460 |
| | 96402712 | 96402717 | 575★ |

Connections

| Flange size | Flange type |
|--|-------------|
| 1.25" non ANSI 2 bolt w/ (2) 0.5" dia. holes | GF 15/26 |

Electrical data

| Speed | Max amps [A] | | | P Max [Watts] | Start amps [A] | | |
|-------|--------------|------|-------|---------------|----------------|------|-------|
| | 208-230V | 460V | 575V★ | | 208-230V | 460V | 575V★ |
| 3 | 1.10 | 0.55 | 0.44 | 280 | 5.00 | 2.80 | 2.20 |
| 2 | 0.72 | 0.36 | 0.29 | 235 | 3.93 | 1.96 | 1.60 |
| 1 | 0.58 | ▲ | ▲ | 195 | 3.16 | ▲ | ▲ |

▲ All 3-phase, 460V and 575V pumps are 2-speed only.
★ Canada only.