

**UPS 75-69/2, 1 ph, 230 V, 60 Hz**

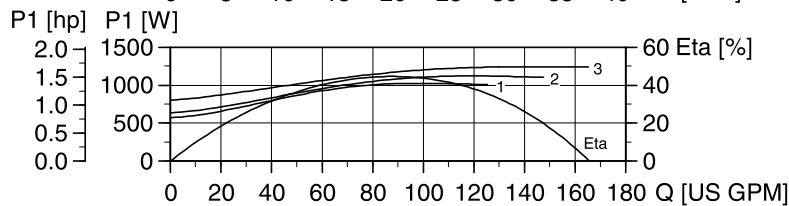
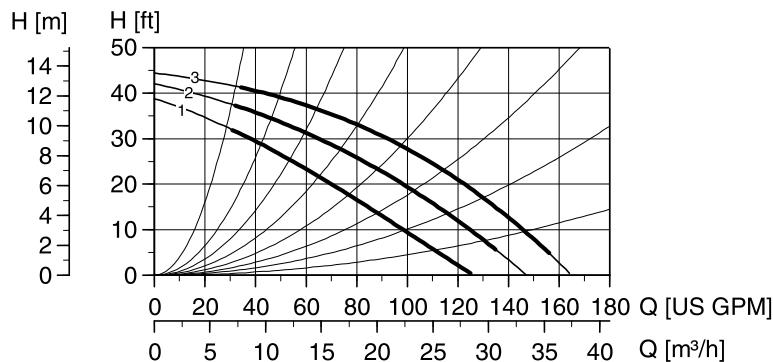

TM00 9413 0307

- Flow range: 20 - 170 gpm
- Head range: 1 - 46 ft
- Motor: 2-pole 1.25 Hp
- Max. liquid temp (Open): +140 °F
- Max. liquid temp.: +248 °F
- Min. liquid temp.: +32 °F
- Max. system pressure: 145 psi
- Net wt: 53.6 lbs (24.3 kg)
- Gross wt.: 65.7 lbs (29.8 kg)
- Shipping volume: 3.50 ft<sup>3</sup> (0.098 m<sup>3</sup>)
- Net wt. bronze: 68.3 lbs (31.0 kg)
- Gross wt. bronze: 80.5 lbs (36.5 kg)
- Shipping volume bronze: 3.50 ft<sup>3</sup> (0.098 m<sup>3</sup>)

**Note:** ETA is calculated as wire-to-water efficiency.

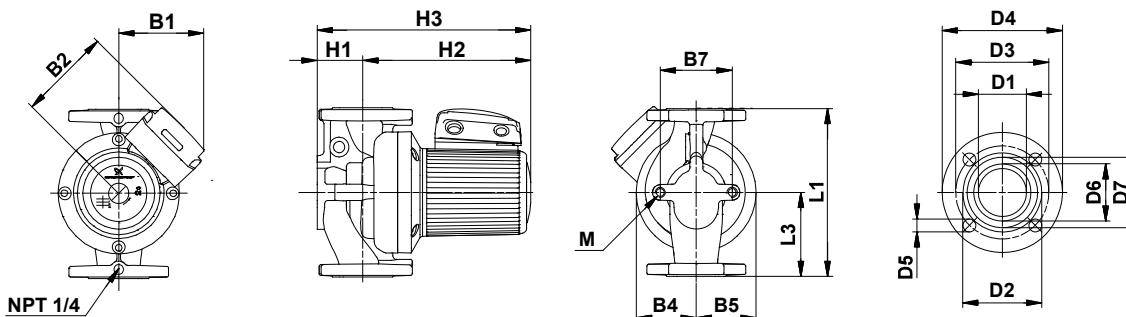

TM02 0730 5100

**Dimensions**

Model	L1	L3	B1	B2	B4	B5	B7	H1	H2	H3	D1	D2	D3	D4	D5	D6	D7	M	
UPS 75-69/2	[in]	14.25	7.13	5.69	6.68	3.94	3.94	4.50	2.94	10.81	13.78	2.94	4.31	6.00	7.50	0.75	6.50	4.00	
	[mm]	362	181	145	170	100	100	114	75	275	350	75	109	152	191	19	165	102	M12

**Product numbers**

Model type	Product number		Voltage [V]
	Cast Iron	Bronze	
UPS 75-69/2 (1 ph)	96654378	96654397	230

**Connections**

Flange size	Flange type
3" ANSI 125# R.F.	GF80

**Electrical data**

Speed	Max amps [A]	P Max [Watts]	Start amps [A]
	230V		230V
3	5.80	1250	26.50
2	5.20	1100	23.76
1	4.85	1050	22.16