

ADJUSTABLE FLASHING DRAIN

» 833 SERIES

FinishLine™

ITEM # SUBMITTED	_____
JOB NAME	_____
LOCATION	_____
ENGINEER	_____
CONTRACTOR	_____
PO#	_____ TAG _____

SPECIFICATION

Sioux Chief 833 series FinishLine adjustable above-grade flashing drain shall be used where necessary in drainage systems. Flashing drain shall allow adjustment of 1¼" before the concrete pour, and 1¼" after the concrete pour. Flashing drain shall have an invertible flashing collar and cast iron base adapter. Strainer shall meet applicable load requirements for intended use. Trap primer port shall be threaded ½" FIP for optional connection. Designed in accordance with ASME A112.6.3-2001.

MATERIALS

Ring/strainer: Nickel bronze, 301 stainless steel
Head adapter/Coring sleeve/Clamping collar: Gray ABS
Coring plug: High-impact polymer
Base adapter: Cast iron

STRAINER LOAD RATING

	Large Top:	Standard Top:
Nickel bronze (heel-proof):	750 lbs. (light duty)	1,650 lbs. (light duty)
Stainless steel (heel-proof):	1,000 lbs. (light duty)	2,000 lbs. (light duty)

STRAINER FREE AREA

	Large Top:	Standard Top:
Round Nik-Brz/Stainless:	11.75 in ²	7.5 in ²
Square Nik-Brz/Stainless:	16.4 in ²	12.75 in ²

DIMENSIONS

A: Connection size	2", 3", 4"
B: Ring/strainer diameter	
Round (Std./Large)	5½" / 6½"
Square (Std./Large)	5⅞" / 7"
C: Flange diameter	8½"
D: Base Adapter height*	4"
E: Pre-pour adjustable height*	5" – 7"
F: Post-pour adjustable height	
round/square	0" – 1¼" / ⅝" – 1¼"

* Max height noted with inverted flashing collar
 Add ⅜ for Push-Joint or Inside-Caulk connection. Subtract 1" for FIP connection



833-625NQ

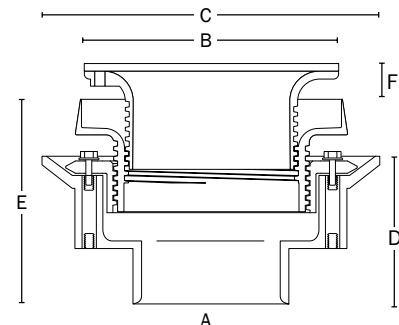

Create Item Number

833-A B C D

e.g. 833-625NQ: FinishLine 2" Push-Joint adjustable flashing drain with square nickel-bronze ring and strainer

CONNECTION TYPE **A**

- 2 = Cast iron No-Hub
- 6 = Cast iron Push-Joint
- 7 = Cast iron Inside-Caulk
- 8 = Cast iron FIP thread

CONNECTION SIZE/TOP SIZE **B**

- 2 = 2" conn./Large top
- 25 = 2" conn./Std. top
- 3 = 3" conn./Large top
- 35 = 3" conn./Std. top
- 4 = 4" conn./Large top

RING/STRAINER TYPE **C**

- NR = Round nickel bronze
- SR = Round stainless steel
- NQ = Square nickel bronze
- SQ = Square stainless steel

OPTIONS (INSTALLED) **D**

- V = Vandal-resistant strainer screws
- B = Complies with Buy American Act
- E = 1¼" extended strainer rim
- H = Hinged strainer²
- P = Sch. 40 Push-Joint gasket⁴

ACCESSORIES

- 832-S3 = Leveling shim kit for Std. top
- 832-S4 = Leveling shim kit for Large top
- 832-UM = Stainless mesh debris bucket for Large top
- 832-W = Flexible locating bristles kit
- 832-EX3 = Ductile extension adapter for Std. top⁵
- 832-EX4 = Ductile extension adapter for Large top⁵
- 863-FN = Round nickel bronze condensate funnel
- 863-FNO = Oval nickel bronze condensate funnel
- 863-FA = Round aluminum condensate funnel

- 1 FIP connection available in 2" only
- 2 Available for Large top only
- 3 Available for round NB strainers only
- 4 In place of standard gasket - not available for 2"
- 5 Extends head 2" (min) to 4" (max) above Coring Sleeve