



AQUARIUS
®

Kelvinator®

White-Westinghouse®

ILLUSTRATED PARTS BREAKDOWN

WATER COOLER MODELS

PLF7P-D100

PLF13P-100

PSF13P-100

PLF13PL-100

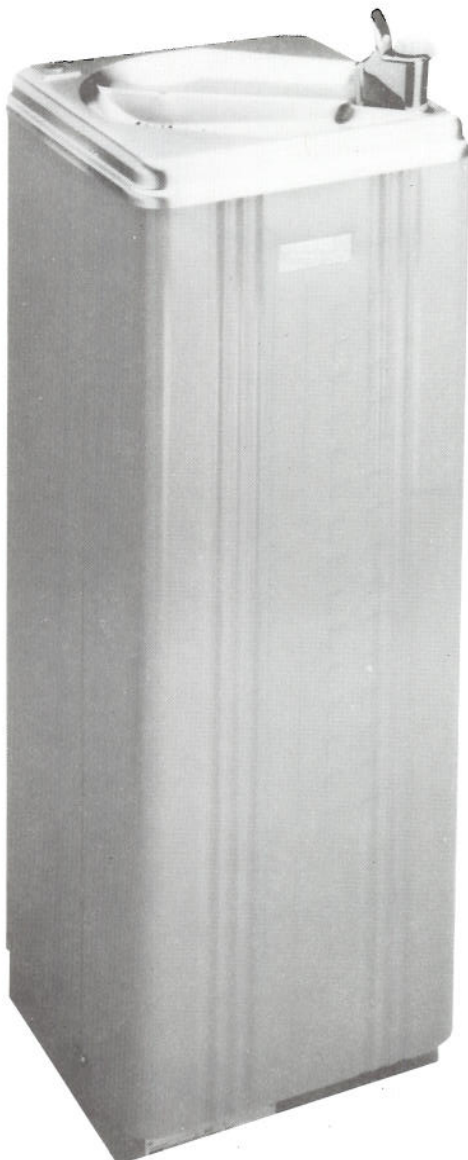

SPECIFICATIONS

7P MODELS

Voltage	115 VAC ±10%/1PH/60 Hertz
Size (Approx)	40" H., 15" W., 15" D.
Shipping Weight (Approx)	73 LBS.
Cold Water Capacity	7 GPH
Compressor	1/8 HP
Compressor Amps (Full Load)	2.5
Refrigerant	134A
Refrigerant Charge	3-3/4 OZ. (106 GRAMS)

13P MODELS

Voltage	115 VAC ±10%/1PH/60 Hertz
Size (Approx)	40" H., 15" W., 15" D.
Shipping Weight (Approx)	80 LBS.
Cold Water Capacity	13 GPH
Compressor	1/5 HP
Compressor Amps (Full Load)	5.0
Refrigerant	134A
Refrigerant Charge	4-7/8 OZ. (138 GRAMS)

13PL MODELS

Voltage	115 VAC ±10%/1PH/60 Hertz
Size (Approx)	30" H., 15" W., 15" D.
Shipping Weight (Approx)	70 LBS.
Cold Water Capacity	13 GPH
Compressor	1/5 HP
Compressor Amps (Full Load)	5.0
Refrigerant	134A
Refrigerant Charge	4-7/8 OZ. (138 GRAMS)

*A.R.I. Rating: Room Temperature 90°F; Supply Water Temperature 80°F; Drinking Water Temperature 50°F.

Specifications subject to change without notice.

PARTS LIST

ITEM NO.	DESCRIPTION	PLF7P-D	PLF13P PSF13P	PLF13PL
1	Bubbler Valve 12000A	030774-002	030774-002	030774-002
2	Valve Body Gasket	028706-006	028706-006	028706-006
3	Friction Washer	028706-013	028706-013	028706-013
4	Drain Screw	026655-002	026655-002	026655-002
5	Hole Cover	016994	016994	016994
6	Top	028845-001	028845-001	028845-001
7	Supply Spud Gasket	028706-001	028706-001	028706-001
8	Waste Gasket	027389-001	027389-001	027389-001
9	Bubbler Supply Spud	028701-002	028701-002	028701-002
10	Upper Cabinet Bracket	027407-001	027407-001	027407-001
11	Precooler Assembly	027412-001	027412-001	027412-001
12	Cooling Tank Insulation – R.H.	028660-001	028660-001	028660-001
	Cooling Tank Insulation – L.H.	028661-001	028661-001	028661-001
13	Insulated Cooling Tank	031934-003	031934-001	031934-001
14	Cold Control	027040-007	027040-007	027040-007
15	Condenser	031836-001	018252-001	018252-001
16	Front Panel – Tan	024442-005	024442-005	024442-009
	Front Panel – Stainless Steel	024442-003	024442-003	024442-011
17	Cabinet – Tan	015570-002	015570-002	015569-002
	Cabinet – Stainless Steel	015570-005	015570-005	015569-005
18	Compressor (Includes Items 19 and 20)	031530-003	031525-003	031525-003
19	Overload	---	031697-001	031697-001
20	Relay	026867	031698-001	031698-001
21	Base – Tan	028199-001	028199-001	028199-001
	Base – Stainless Steel	028199-002	028199-002	028199-002
22	Service Cord	026540-003	026540-038	026540-038
23	Fan Blade	022977	022977	022977
24	Fan Motor	027354-029	027354-027	027354-027
25	Fan Bracket	017530	017530	017530
26	Fan Shroud	029656-001	029656-001	029656-001
ACCESSORY PARTS				
	Glass Filler Installation Kit	031505-001	031505-001	031505-001
	Foot Pedal Kit	026645-014	026645-014	026645-013
	Selecto Filter (PSF13P only)	---	029681-002	---
	Refrigerant Drier	031593-005	031593-003	031593-003

ELECTRICAL DIAGRAM

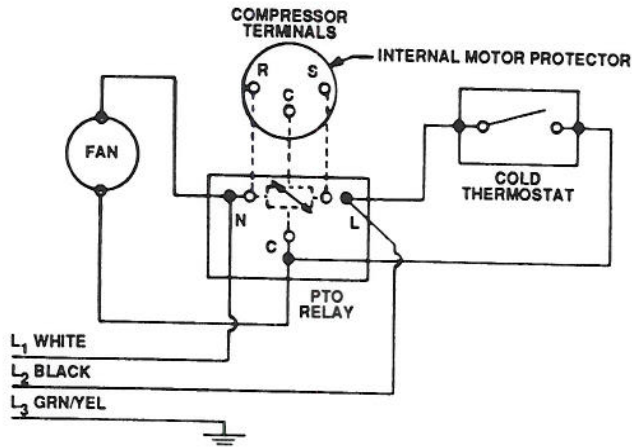

PLF7P-D

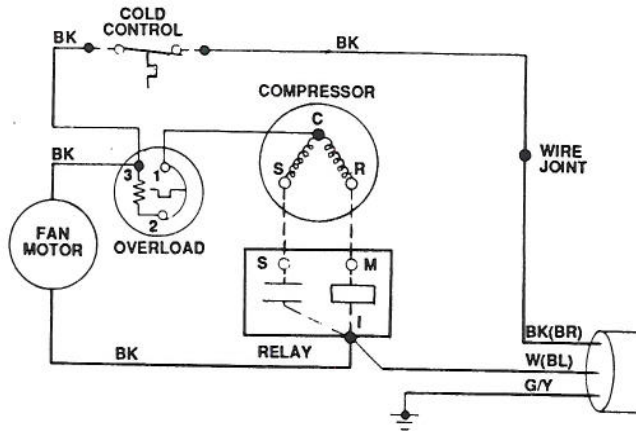

PLF13P
PLF13PL
PSF13P

OASIS® & AQUARIUS® are registered trademarks of EBCO Manufacturing Company
The trademarks Kelvinator® and White-Westinghouse® are used under license from White Consolidated Industries, Inc.

EBCO® MANUFACTURING COMPANY

265 N. Hamilton Rd. • P.O. Box 13150 • Columbus, OH 43213-0150 • 614/861-1350 • Fax: 614/861-5017

Printed in U.S.A.
Copyright 1994 EBCO Manufacturing Co.