

Maintenance

Filter

▲ WARNING: To reduce the risk of injury from accidental starting, unplug power cord before changing or cleaning filter.

1600RV and 1650RV Professional Wet/Dry Vacs are supplied with RIDGID's Qwik Lock™ Fine Dust Filter. Replacement Qwik Lock™ Filters are available where you purchased your Vac. Ask for the RIDGID Qwik Lock™ Fine Dust Filter VF5000.

NOTE: The filter is made of high quality paper designed to stop very small particles of dust. The filter can be used for wet or dry pick up. Handle the filter carefully when removing to clean or installing it. Creases in the filter pleats may occur from installation but not affect the performance of the filter.

Filter Removal and Installation of the Qwik Lock™ Filter

Filter Removal:

1. Hold the filter tabs of the Qwik Lock™ filter in each hand.
2. With one thumb on the Qwik Lock™ stud, which protrudes through the integrated filter plate, lift up on the filter tabs while pushing down on the stud.
3. This action will cause the filter to release from the filter cage. Slide filter off cage.

Filter Installation:

1. Carefully slide the Qwik Lock™ filter over the filter cage and press down on the outside edge of the filter until the rubber gasket on the bottom of the filter seats securely around the base of the filter cage and against the bottom of the drum.

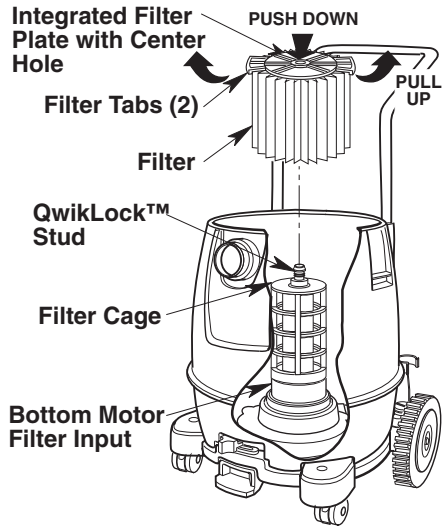

2. Align the small center hole in the top of the filter over the Qwik Lock™ stud on the filter cage. Press firmly on top of the filter near the stud to allow the filter to snap over the ball on the end of the stud. The filter is now attached.

NOTE: Failure to properly seat the bottom gasket could result in debris bypassing the filter.

IMPORTANT: To avoid damage to the blower wheel and motor, always reinstall the filter before using the Vac for dry material pick-up.

Cleaning a Dry Filter

NOTE: For best cleaning results due to accumulated dust, clean the filter in an open area. Cleaning SHOULD be done outdoors and not in the living quarters.

1. Remove filter from Vac. Gently tap filter against the inside wall of your dust drum. The debris will loosen and fall.
2. For thorough cleaning of dry filter with fine dust (no debris), run water through it as described under "Cleaning a Wet Filter".

Maintenance (Continued)

Cleaning a Wet Filter

After filter is removed, run water through the filter from a hose or spigot. Take care that water pressure is not strong enough to damage filter. Allow filter to dry out before re-installing in the vacuum.

IMPORTANT: After cleaning, check the filter for tears or small holes. Do not use a filter with holes or tears in it. Even a small hole can cause a lot of dust to come out of your Vac. If your filter is worn or damaged, replace it immediately.

Allow the filter to dry before reinstalling and storing the Vac.

Cleaning and Disinfecting the Wet/Dry Vac

To keep your Wet/Dry Vac looking its best, clean the outside with a cloth dampened with warm water and mild soap.

To clean the drum:

1. Dump debris out.
2. Wash drum thoroughly with warm water and mild soap.
3. Wipe out with dry cloth.

Before prolonged storage or as needed (i.e.; waste water pick up), the drum should be disinfected.

To disinfect the drum:

1. Pour 1 gallon of water and 1 teaspoon chlorine bleach into the drum.
2. Let solution stand for 20 minutes, carefully swishing every few minutes, making sure to wet all inside surfaces of the drum.
3. Empty drum after 20 minutes. Rinse with water until bleach smell is gone. Allow drum to dry completely before sealing the motor on the drum.

Cord Maintenance

When vacuuming is complete, unplug the cord and wrap it around the motor cover. If the power cord is damaged, it must be replaced by the manufacturer or their service agent or by similarly qualified personnel to reduce the risk of accident.

If the ALCI is preventing the vacuum from operating, then the Vac should be returned to a service center for examination and repair.

Storage

Before storing your Vac, the drum should be emptied and cleaned. The cord should be wrapped around the unit and the hose should be stored as described in this manual. Accessories should be kept in the same area as the Vac so they can be readily available. The Vac should be stored indoors.

Casters and Wheels

Should your cart squeak or become hard to roll, you should place two or three drops of general purpose oil on each wheel at the axle. If your casters are noisy, you may put a drop of oil on the roller shaft to make them quieter.

Frame and Handles

Your metal handle is painted to prevent rust, however, liquids and corrosive debris should be wiped off with a soft cloth should they come in contact with the handle.

⚠ WARNING: To assure product SAFETY and RELIABILITY, repairs and adjustments should be performed by Authorized Service Centers, always using RIDGID replacement parts.