

Liquid End Sheet

LE-155HV

When pumping solutions, make certain that all tubing is securely attached to the fittings. It is recommended that tubing or pipe lines be shielded to prevent possible injury in case of rupture or accidental damage. Always wear protective clothing and face shield when working on or near your metering pump.

Note: See parts list for materials of construction

A. INSTALLING INJECTION CHECK VALVE

1. The purpose of the injection check valve is to prevent backflow from the treated line.
2. A ½" NPT female fitting with sufficient depth will accept the injection check valve.
3. To insure correct seating of the ball inside the injection check valve, the injection check valve should be installed upwards (vertically) into bottom of the pipe.

B. CONNECTING DISCHARGE TUBING

NOTE: Cut tubing to length needed for discharge line.

1. Route tubing from the injection check valve to the metering pump, making sure it does not touch hot or sharp surfaces, or is bent so sharply that it kinks.
2. Slide the small end of the coupling nut onto tubing, then slide on the clamp ring.
3. Push tubing on the valve housing nozzle so that tubing flares out and butts up against valve housing and will not go any further.
4. Slide the clamp ring and coupling nut to the threads and engage. While pushing the tubing onto the valve housing nozzle, tighten the coupling nut by hand until tubing is held securely in place.

*Excessive force will crack or distort fittings.
DO NOT USE PIPE WRENCH.*

C. CONNECTING SUCTION TUBING

Flooded Suction (Preferred Method)

1. Mount pump 12" above the floor with the head extending beyond mounting surface so the suction tubing curves gently away from the pump to prevent kinking.
2. Install 1/2" or 3/4" NPT shut off valve, with at least 3/4" clear way through the valve, into reservoir. This is necessary to stop flow from reservoir while servicing the pump.
3. Install barbed connector (one of two [2]supplied) into the valve. Attach 15/16" O.D. Vinyl tubing to the barbed connector. Secure with the hose clamp provided (use shortest length of suction tubing necessary).

4. Connect the other end of the suction fitting at the pump and secure with the hose clamp provided.

D. CONNECTING SUCTION TUBING

Suction Lift (Pump Sitting on Barrel: Maximum Lift 3.5 ft)

1. Connect the suction tubing to the barbed suction fitting on the pump. Secure with the hose clamp provided.
2. Cut tubing so it will only reach within 1" of the bottom of the barrel.
3. If tubing curl is a problem, fabricate a 1" Polypropylene or PVC pipe as a tubing straightener (pipe should be slightly longer than the depth of the barrel for ease of removal).
4. Place the tubing straightener over the suction tubing and lower into the barrel.

E. PRIMING

1. Temporarily remove tubing from the injection check valve and hold the end of tubing so it is above the level of the pump.
2. Start pump. Set at 80% speed and 100% stroke.
3. As soon as solution is visible through translucent discharge tubing, just past the discharge valve, stop the pump.
4. The pump is now primed.
5. Reconnect tubing to the injection check valve.

NOTE:

- (a) Pump is normally self-priming if suction lift is not more than 3.5 ft (1 m), valves in the pump are wet with water (pump is shipped from factory with water in pump head) and the above steps (D. Priming) are followed.
 - (b) If the pump does not self prime, remove discharge valve housing and ball and pour water or solution slowly into discharge port until head is filled. Follow step D. Priming thereafter.
6. If difficulty is experienced on the initial prime, apply vacuum to discharge tubing by suitable means, such as a hand suction pump. Difficulty should not reoccur after pump is primed with a viscous liquid.



8 Post Office Square
Acton, MA 01720 USA
TEL: (978) 263-9800
FAX: (978) 264-9172
<http://www.lmipumps.com>



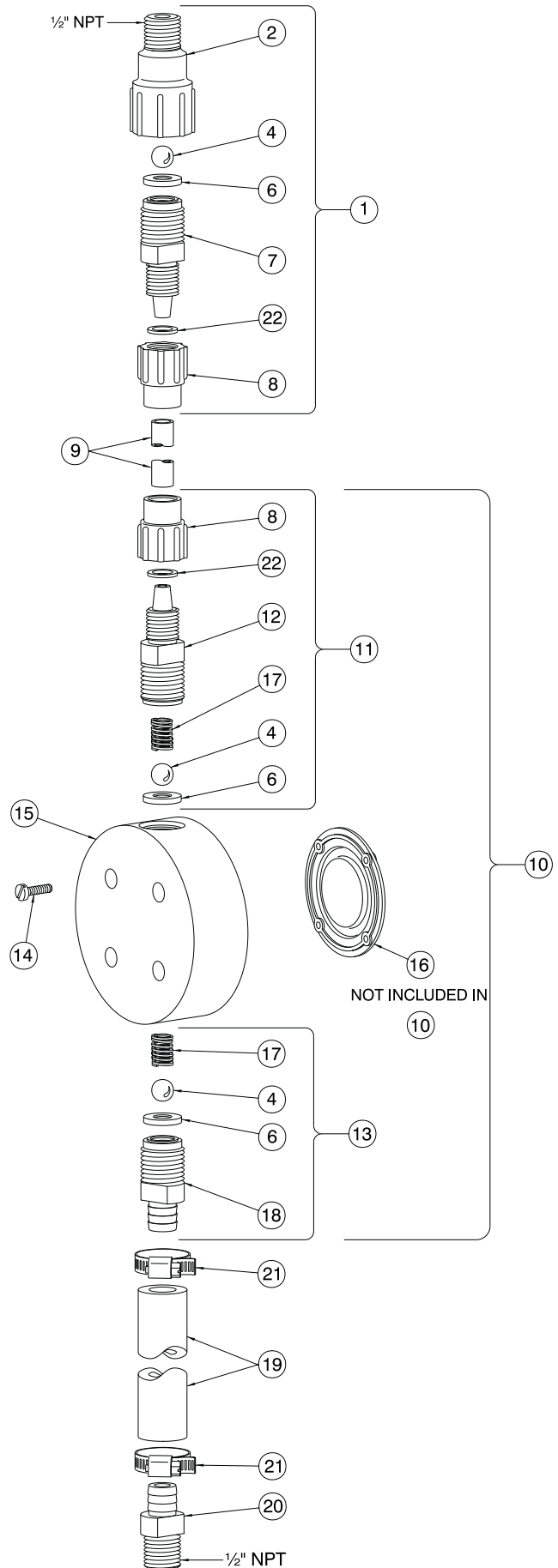

NOTE:
Threaded connections into pump head are 1"-12 straight threads. **DO NOT USE TEFLON® TAPE.** These joints are sealed by seal ring valve seats (item 7 on exploded view).

KEY NO.	PART NO.	DESCRIPTION	QTY.
1	27080	Injection Check Valve Assembly	1
2	25108	Injector Fitting, Polypropylene	1
4	25042*	Ball, Stainless Steel .500"	3
6	25128*	Seal Ring, PTFE	3
7	25106	Valve Seat, Polypropylene .500"	1
8	10411	Coupling Nut, Polypropylene	2
9	10142-10	Tubing, Polyethylene, .5" O.D.	1
10	28416	Head Assembly, LE-155HV	1
11	27052	Discharge Valve Assembly	1
12	25173	Valve Housing, Polypropylene .500"	1
13	27053	Suction Valve Assembly	1
14	10340	Screw, 10-24 x 3/4" S.S.	4
15	28391	Head, High Viscosity 0.5 S.I. PP	1
16	30916*	Liquifram™, 0.5 Fluorofilm™	1
17	25558*	Spring, Stainless Steel	2
18	25649	Valve Seat, Polypropylene, Barbed	1
19	25651-3.5	Tubing, Vinyl, .938" O.D.	1
20	25650	Connector, Barbed, 1/2" NPT	1
21	25652	Hose Clamp	2
22	37203	Clamp Ring	2

*Parts included in Spare Parts Kit No. SP-155HV.