

REPLACEMENT PARTS

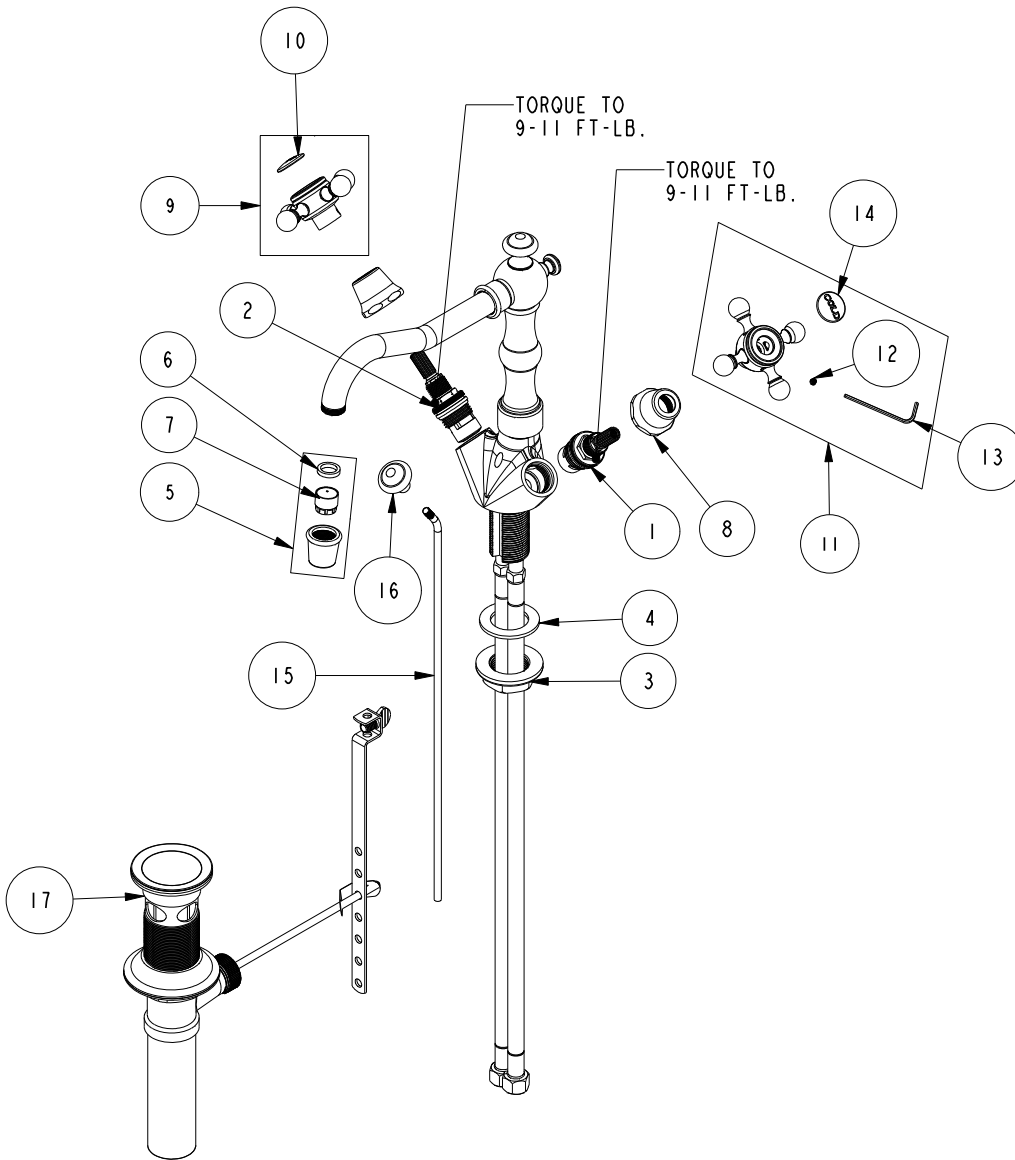

ITEM	PT/ASSY	SPECIFY FINISH	DESCRIPTION
1	1-002		W/S CARTRIDGE - HOT
2	1-001		W/S CARTRIDGE - COLD
3	91050		MOUNTING NUT - 3/4 NPSM
4	91045		WSHR, 1.0 ID X 1.56 OD X .094 THK, FLT, NEO
5	2-633	YES	AERATOR ASM
6	91265		WSHR, 11 ID X 15 OD X 2.8 MM THK, FLT, RUBBER NSF 61 APPR
7	12402		AERATOR INSERT, TT SIZE, 1.2 GPM
8	10331	YES	BONNET FOR 933, 934
9	2-141	YES	HANDLE ONLY, HOT
10	1-108		HOT BUTTON ASSEMBLY W/ ADHESIVE
11	2-142	YES	HANDLE ONLY, COLD
12	92000		SCREW 8 - 32 X 1/8 SS
13	10192		HEX KEY TOOL, #8 5/64
14	1-107		COLD BUTTON ASSEMBLY W/ ADHESIVE
15	10419	YES	BENT POP-UP
16	10539	YES	POP-UP KNOB
17	325	YES	POP UP ASSEMBLY

**SINGLE-HOLE LAVATORY FAUCET
932**

REV H EN-4740 11/28/23 APPROVED R.S.

NEWPORT BRASS.

t: 949.417.5207 | www.newportbrass.com