

4

3

2

1

## NOTES:

(N1) 1. FIT / FORM / FUNCTION SHALL FOLLOW PS-E.008.

2 APPLY LOCTITE 680.

3 CUT AND SHORTEN O-RING BY .13" TO .20" IN LENGTH BEFORE INSTALLING.

4 SLIT O-RING BEFORE INSTALLING.

5 APPLY LOCTITE 242.

(N6) 6. WATER TEST WHOLE UNIT.

7 BAG 5-007 IN A SEPARATE BAG.

8 INSTALLATION TORQUE: 8-14 LB-FT.

9 APPLY LIGHT FILM OF DOW CORNING 111 SILICONE COMPOUND.

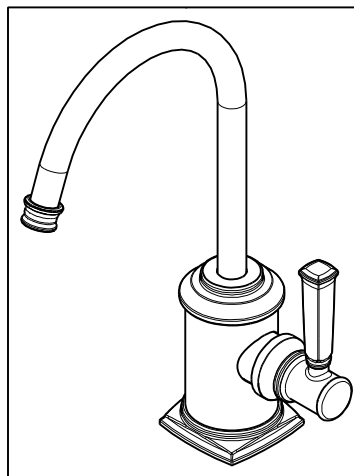

## BILL OF MATERIAL (CURRENT LEVEL)

ITEM	PT/ASSY	DESCRIPTION	TYPE	QTY.
1	20-293	ESCUTCHEON ASM	ASSEMBLY	1
2	50715	WATER DISP BODY (CONT.)	PART	1
3	50717	WATER DISP SPOUT RETAINER	PART	1
4	91023	O-RING, #2- 019, EPDM, 65-75 DURO, NSF 61	PART	1
5	50713	SPOUT, WATER DISP. (TRAD.)	PART	1
6	11733	SHELL, SPOUT, WATER DISP	PART	1
7	91382	O-RING, #2- 012, TEFLON,	PART	1
8	91017	O-RING, #2- 012, EPDM, 65-75 DURO, NSF 61	PART	2
9	12708	BODY CAP	PART	1
10	91383	O-RING, #2- 014, TEFLON, NSF 61	PART	1
11	50714	WATER DISP. CAR.T HOLDER	PART	1
12	12512	BONNET	PART	1
13	1-134	CARTR 3/8 HOT 1/4 TR	PART	1
14	12750	ADAPTER	PART	1
15	50760	NIPPLE WATER DISP	PART	1
16	5-007	1/4 COMP KIT	ASSEMBLY	1
17	10661	MOUNTING STUD	PART	1
18	91063	MOUNTING CRESCENT GASKET	PART	1
19	10514	MOUNTING CRESCENT	PART	1
20	10516	MOUNTING NUT	PART	1
21	92862	SCRW, M4 X 18 SKT FLT HD SS	PART	1
22	20-291	HANDLE HUB ASM	ASSEMBLY	1

TESTING	-	-	-
ASSEMBLY	-	-	-
PLATING	-	-	-
POLISHING	-	NEXT ASSY	USED ON
MACHINING	-	APPLICATION	
TOOLING FIXTURE #		REMOVE ALL BURRS AND SHARP EDGES	

UNITS ARE: INCHES [MM]  
TOLERANCES ARE:  
FRACTIONS DECIMALS ANGLES  
 $\pm 1/16"$  .X  $\pm .1$  [2.5]  $\pm 1^\circ$   
.XX  $\pm .06$  [1.5]

(X.XXX) DENOTES CRITICAL DIMS.  
ALL THREADS ARE CRITICAL

DRAWN JINSON 08/29/18  
CHECKED J.M. 08/29/18  
APPROVED J.M. 08/29/18

**BRASSTECH**  
INCORPORATED

2001 CARNEGIE AVE.  
SANTA ANA, CA 92705  
(949) 417-5207

WATER DISPENSER - COLD

DWG NO. 3160-5623

REV A

SCALE .300 REF. - SHEET 1 OF 3

COPYRIGHT 2005 BRASSTECH, INC.  
THESE DRAWINGS AND THE DESIGNS  
DEPICTED HEREIN ARE THE PROPRIETARY  
PROPERTY OF BRASSTECH. ANY USE  
OR REPRODUCTION IS SUBJECT TO  
THE EXPRESS APPROVAL OF BRASSTECH.  
UNAUTHORIZED USE IS STRICTLY  
PROHIBITED. ALL RIGHTS RESERVED.

ZONE	REV	DESCRIPTION	DATE	APPROVED
-	A	EN-3693	08/29/18	J.M.
-	-	EN-3229	08/21/17	J.M.

4

3

2

1

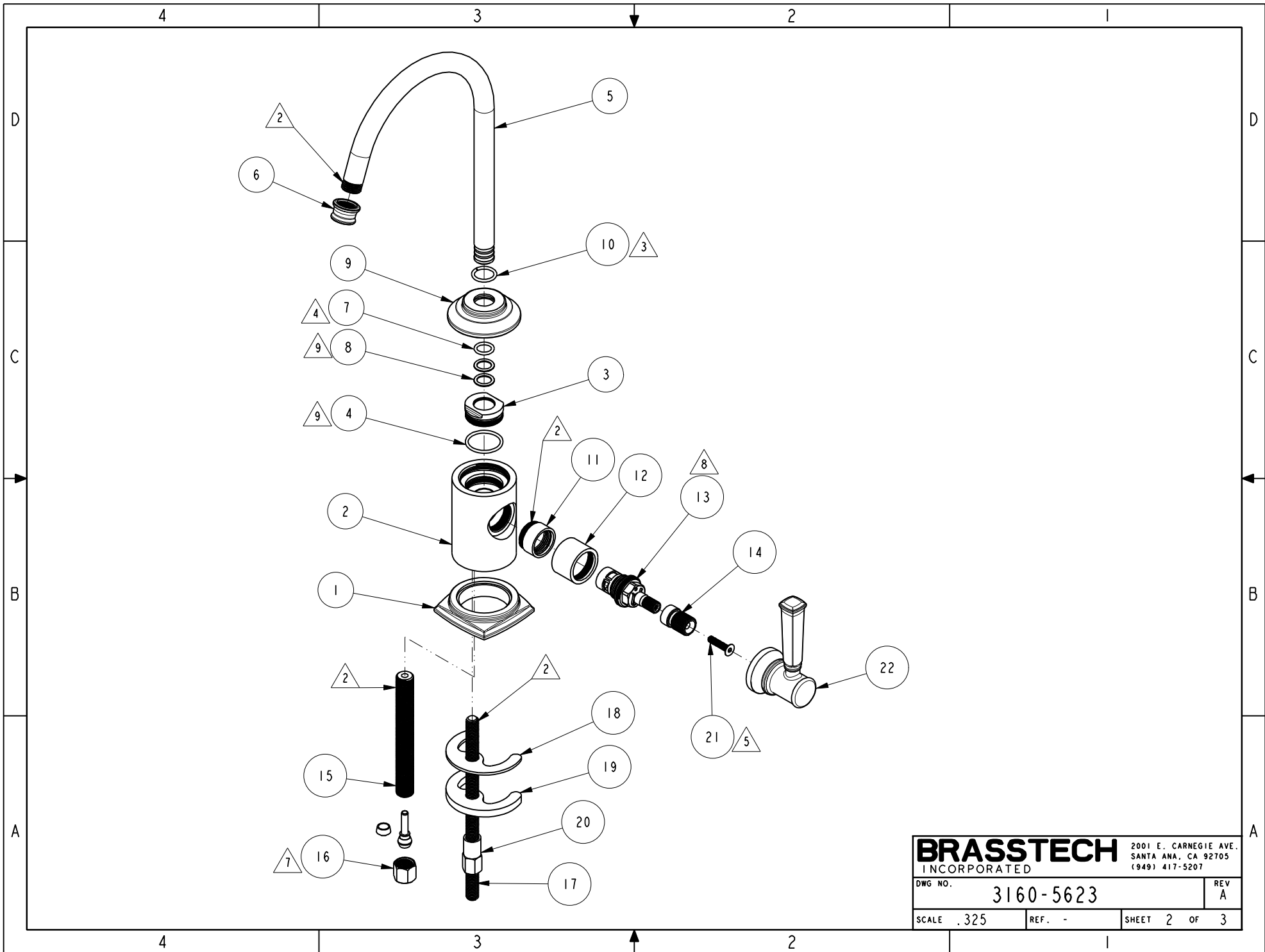

<b>BRASSTECH</b>		2001 E. CARNEGIE AVE. SANTA ANA, CA 92705 (949) 417-5207	
DWG NO.	3160-5623	REV	A
SCALE .325	REF. -	SHEET 2	OF 3

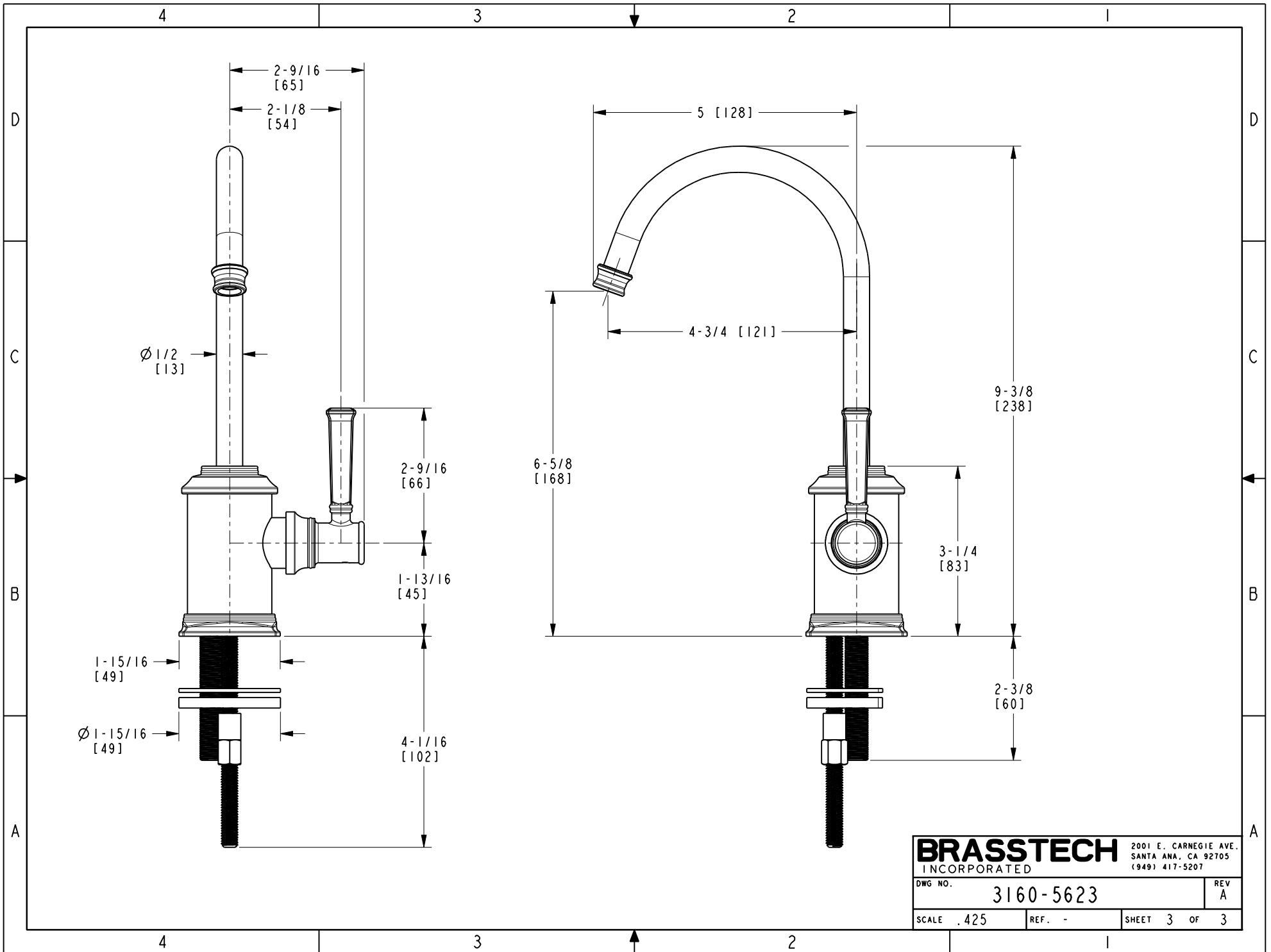

**BRASSTECH** 2001 E. CARNEGIE AVE.  
 INCORPORATED SANTA ANA, CA 92705  
 (949) 417-5207

DWG NO.	3160-5623	REV	A
SCALE	.425	REF.	-
SHEET 3		OF 3	