



NG-1 100 / NG-1 250 Installer's Manual

DOC NG-1-100-250-OM REV 1 12/2019

The power behind **your mission**



Table of Contents

1. Safety.....	2
2. System and Product Introduction.....	4
a. Dry Pipe Nitrogen Inerting	
b. Dry Pipe Nitrogen Inerting Equipment	
c. Recommended Monitoring Equipment	
3. Generator Technical Specifications.....	7
a. NG-1 100	
b. NG-1 250	
4. Operational Information.....	9
5. Start-up and Operation Procedures.....	12
a. Mounting	
b. Required System Wiring	
c. Start-Up Procedure	
d. Normal Operation	
e. Fire Sprinkler System Maintenance Procedure	
6. Sequence of Operation.....	21
7. Oxygen Removal Vent	25
a. TYCO Manual Vent	
b. TYCO SMART Vent	
8. Monitoring.....	32
a. In-Line Corrosion Detector	
b. SMART Gas Analyzer	
9. Commissioning.....	40
a. Nitrogen Generator	
b. Oxygen Removal Vents	
10. Maintenance.....	45
a. Routine Checks	
b. Nitrogen Purity and Flow Rate	
c. Filter Replacement	
d. Vent Maintenance	
e. Generator Configuration Diagram	
11. Troubleshooting.....	60
12. Wiring Diagram.....	61
13. Replacement Filters.....	67
14. Commissioning Checklist	68
15. System Summary	74
16. Inspection Testing and Maintenance Form	75

Safety

Safety Guidelines

The manual contains safety information that is important to know and understand. The information is provided for the safety of the installers, operators and users of the TYCO Nitrogen Generation Systems, as well as the nitrogen generation equipment.

The Installation and Operations Manual that is supplied with each nitrogen generation system must be read thoroughly and be completely understood prior to installing and operating TYCO Nitrogen Generation System. All appropriate safety standards for the handling of gases as determined by local, state or national laws and regulations are to be followed at all times.

General Safety Information

IMPORTANT: Read all the safety information in the manual prior to operating the equipment. Use of the equipment in a manner not specified within the manual could impair the protection provided by the nitrogen generation system and could result in an unintended release of pressure which could cause serious injury or damage. Only personnel that are qualified, and have been trained and approved by Johnson Controls can perform commissioning, servicing and repair procedures.

When handling, installing, or operating the nitrogen generation equipment, the personnel must employ safe engineering practices and observe all related local, state and national regulations, health, and safety procedures, and legal requirements for safety.

Ensure the nitrogen generation equipment is depressurized and electrically isolated, before performing any maintenance or troubleshooting instructions specified in this manual.

The warnings covered in this manual are the most known potential hazards, but by definition cannot be all-inclusive. If the user employs an operating procedure, item of equipment, or method of working that is not specifically recommended by Johnson Controls, the user must ensure that the equipment will not be damaged or become hazardous to any persons or property.

Cautions and Warnings

CAUTION: Do not install the TYCO Nitrogen Generator or Air Compressor Package in an area where ammonia, sulfur dioxide, hydrogen sulfide, mercaptans, chlorides, chlorine, oxides of nitrogen, acid fumes, solvent vent vapors, and ozone vapors or similar contaminants exist. The equipment can be damaged by ammonia and other vapors shortening membrane life.

WARNING: Do not operate the TYCO Nitrogen Generation System if damaged during shipment, handling or use. Damage could result in injury or property damage.

WARNING: Operation of the nitrogen membrane above the rated design pressure could be hazardous. Do not connect the nitrogen generation equipment to compressed air sources that can exceed the maximum rated pressure without installing pressure controls and safety relief devices in the compressed air supply line

Specific procedures must be developed for maintenance and servicing of the equipment where the nitrogen membrane is located. Appropriate labels must be continuously displayed in all areas where personnel might be exposed to a nitrogen atmosphere under normal and abnormal conditions.

WARNING: Nitrogen is nontoxic and largely inert. Rapid release of nitrogen gas into an enclosed space displaces the oxygen and can cause an asphyxiation hazard.

Maintenance and Troubleshooting Warnings

1. Nitrogen Generator includes 120 VAC 60 Hz (230 VAC 50 Hz) voltage inside cabinet – exercise caution and do not touch any wiring connections when power is applied to the unit.
2. Nitrogen Generator has hot surfaces inside cabinet when nitrogen generator is operating and after nitrogen generator has turned off – exercise caution when working on nitrogen generator while operating and after nitrogen generator has shut off. (***Wear Hand Protection, where needed***)

Lifting and Troubleshooting Instructions

Nitrogen Generators weigh in excess of 100 lbs (45 kg). When lifting and/or carrying a nitrogen generator proper lifting and carrying techniques must be considered.

1. Keep a wide base of support – Feet should be shoulder-width apart with one knee slightly in front of the other.
2. Squat down bending at hips and knees – If needed, one knee on the floor and other knee in front, bent at a right angle.
3. Keep good posture - Look straight ahead with back straight, chest out, and shoulders back.
4. Slowly lift by straightening your hips and knees (not your back) - Keep your back straight, and don't twist as you lift.
5. Hold the load as close to body as possible.
6. Use feet to change direction - Small steps.
7. Lead with hips as changing direction - Keep shoulders in line with hips as you move.
8. Set down load carefully - Squatting with the knees and hips only.

System and Product Introduction

Dry Pipe Nitrogen Inerting (DPNI)

Dry Pipe Nitrogen Inerting technology is used to control oxygen corrosion in dry and/or preaction fire sprinkler systems. DPNI is executed by employing a “fill and purge” differential pressure cycle (breathing) within the sprinkler pipe network. The “fill and purge” pressure cycle consists of venting the system pressure by 3-5 psi (.2-.3 bar), followed by replacing the vented pressure back into the system. This breathing process uses a nitrogen rich gas stream, typically 98% or greater, for a specific length of time (typically 14 days or less), until a nitrogen-rich, or inert, atmosphere exists within the sprinkler pipe network. By changing the atmosphere inside the pipe network to 98% or higher nitrogen content, the available oxygen content is reduced to a level that will not allow appreciable corrosion of the fire sprinkler pipe. With the level of oxygen corrosion reduced to near zero the effective life of the fire sprinkler system is greatly extended. Systems that implement a DPNI corrosion control strategy should never develop leaks when maintained properly.

Dry Pipe Nitrogen Inerting Equipment

Pre-Engineered Nitrogen Generator

The TYCO Pre-Engineered Nitrogen Generator is a wall mounted, “plug and play” on-site nitrogen generation system that is designed to be installed in-line to the fire sprinkler system riser(s) in dry-pipe and preaction fire protection systems. The TYCO Pre-Engineered Nitrogen Generator includes an oil-less compressor within the nitrogen generator cabinet. The cabinet includes a 3-way ball valve and outlet connection to the fire protection system(s). The 3-way valve allows for the air compressor in the nitrogen generator to be used for maintenance or sprinkler system “fast fill” needs. The TYCO Pre-Engineered Nitrogen Generator has been sized with an air compressor to meet the NFPA 13 30-minute fill requirement for dry pipe fire protection systems based on the criteria defined in the Technical Specifications Section. In applications outside of the defined criteria, a separate air compressor can be used to meet the NFPA 13 30-minute fill requirement. The TYCO Pre-Engineered Nitrogen Generator facilitates “fill and purge” breathing in the fire sprinkler system and has been paired with an TYCO Manual Vent (TAV-D) or a TYCO SMART Vent (TSV-D) installed on the fire sprinkler riser.

Nitrogen Generator Features

The TYCO nitrogen generators with the “fill and purge” breathing technology include the following features:

- Removal of corrosive oxygen from the entire sprinkler system in fourteen (14) days or less
- All equipment is installed in the sprinkler riser room for easier installation and servicing
- No refrigerated driers or nitrogen storage tanks required
- Nitrogen generation system monitoring
- Membrane separation technology with 20-year service life
- Minimal maintenance requirements

Oxygen Removal Vent

To completely remove the oxygen in a dry/preaction fire sprinkler system, it is necessary to install a vent on the main riser of each fire sprinkler system. Vents allow for a system to breathe, which requires a 3-5 psig (.2-.3 bar) pressure range to facilitate removal of oxygen gas from the system. Supervisory nitrogen gas is supplied to the system until the air maintenance device reaches the high-end pressure. The vent slowly releases the gas mixture inside the sprinkler system through the restricted orifice until the system reaches the low-end pressure at which point supervisory nitrogen is supplied to the system again. This process is repeated numerous times until the atmosphere inside the piping network reaches at least 98% nitrogen. The vent is crucial for expedient mixing of the gas and elimination of oxygen inside the system within the specified timeframe. TYCO offers two (2) DPNI vents – the TSV-D SMART Vent and the TAV-D Manual Vent. The TSV-D SMART Vent is an automated vent that when activated will open and vent for the necessary amount of time to achieve the desired inert inner pipe atmosphere, and close automatically when the process is completed. This process is initiated by depressing the “vent” pushbutton on the vent’s control panel. The TAV-D is a manual vent that requires an operator to open the vent’s isolation ball valve when venting is desired, and after a specified time (typically 14 days or less) when the breathing process is completed the operator must manually close the isolation ball valve on the vent.

Oxygen Removal Vent Features

The TYCO oxygen removal vents with the “fill and purge” breathing technology include the following features:

- Removal of corrosive oxygen from the entire sprinkler system in fourteen (14) days or less
- All equipment is installed in the sprinkler riser room for easier installation and servicing
- No support hanger required
- Backpressure regulator preventing system depressurization from vent
- In-line filter to protect restricted venting orifice from contamination

Recommended Monitoring Equipment

In-Line Corrosion Detectors

The TYCO In-Line Corrosion Detector (TILD) is designed to provide an early warning of corrosion activity within the fire sprinkler system. The TILD features a double wall construction that incorporates a thin milled section of pipe (.035” (0.9mm)) surrounded by a full thickness piece of pipe to detect and alert to the presence of corrosion activity. If corrosion occurs the milled section of the TILD will fail prior to the failure of any other section of the pipe wall. When the milled section fails it allows the system to pressurize the chamber outside the milled section of pipe which activates the attached pressure switch on the TILD. The pressure switch can be remotely monitored through a building monitoring system, or locally through the TYCO Remote Test Station (TRTI) which is included with the TILD.

The TILD is placed at strategic locations within the fire sprinkler piping network where corrosion has the highest potential of occurring.

- Wet Systems - The TILD is located in high point of the sprinkler system, typically at the air/water interface in a branch line, where air will be trapped as the system is filled with water.
- Dry Systems - The TILD is located in the supply main piping where trapped water will accumulate.

SMART Gas Analyzer

The TYCO SMART Gas Analyzer provides continuous real-time nitrogen/oxygen concentration levels within a dry/preaction fire protection system. The analyzer samples discharge gas from an adjacent TYCO Manual Vent (TAV-D) or SMART Vent (TSV-D). It is equipped with programmable outputs for one of three different oxygen concentration levels (1%, 3%, and 5%), providing early warning to a user when the nitrogen concentration within the fire protection system falls below the desired level. The TSGA is also equipped with an RS-485 port for optional remote control and monitoring and can also display either oxygen or nitrogen concentration.

Handheld Gas Analyzer

The TYCO handheld gas analyzer allows for quick, convenient reading of nitrogen gas purity levels. The gas analyzer can be connected to any of the sample ports on the TYCO devices such as the nitrogen generator or a vent. Additional sampling ports can be ordered and placed at any point on the systems where gas purity monitoring is desired.

Generator Technical Specifications

NG-1 100 / NG-250

Dimensions	24.5"(622mm)W x 36.5"(927mm)H x 9.25"(235mm)D
Weight	125 lbs (57kg)
Location	Dry Indoor Use
Altitude	Up to 6,560 ft (2,000m)
Temperature Range	40°F - 105°F (5°C - 40°C)
Pollution Degree	2
Nitrogen Generator Cabinet Power Supply	120V/1ph/60Hz (230/1 ph/50 Hz)
Power Consumption	6 Amps
Overvoltage Category	II
Nitrogen/Air Bypass Output Connection	½" NPT Female
Drain Connection	¼" NPT Female
Filter Replacement Part Number	TNGFLTW
NG-1 100	
Air Compressor Output	2.5 SCFM/150 SCFH (70.8 L/min)
Nitrogen Gas Output	0.3 SCFM/20 SCFH (8.5 L/min)
Largest Single Zone Capacity @ 40 psig (2.8 bar)	215 gallons (814 L/min)
Largest Single Zone Capacity @ 20 psig (1.4 bar)	540 gallons (2,044 L/min)
Largest Accumulative System Capacity	675 gallons (2,555 L/min)
NG-1 250	
Air Compressor Output	3.3 SCFM/198 SCFH (93.5 L/min)
Nitrogen Gas Output	0.45 SCFM/27 SCFH (12.7 L/min)
Largest Single Zone Capacity @ 40 psig (2.8 bar)	265 gallons (1,003 L/min)
Largest Single Zone Capacity @ 20 psig (1.4 bar)	590 gallons (2,233 L/min)
Largest Accumulative System Capacity	950 gallons (3,596 L/min)

Nitrogen Quality

N ₂ Purity at Discharge:	98% (maximum of 2.0% oxygen)
N ₂ Pressure at Discharge:	Min: 15 psig (1 bar); Max: feed air pressure minus 15 psig (1 bar)
N ₂ Water Dew Point:	Less than -70°F (-57°C)

FM Approved
UL Listed
CE Certification

Standard 1035
508A Industrial Control Panel

NG-1 100 / NG-1 250 Dimensions



Operational Information

System Operating Pressures

When multiple dry-pipe and/or pre-action fire sprinkler systems are connected to one nitrogen generator, the fire sprinkler systems must operate at the same supervisory gas pressure.

In applications where multiple dry-pipe and/or pre-action fire sprinkler systems are connected to one nitrogen generator and there is more than one supervisory gas pressure a TYCO Nitrogen Interface Controller (TNIC) must be included in the project.

System Operating Pressure Adjustments

The nitrogen generator operating pressure settings in conjunction with the pressure setting of the fire sprinkler system's air maintenance device(s) are established and set during the commissioning process.

- The operating pressure settings of the fire sprinkler air maintenance device(s) or the nitrogen generator must not be readjusted after the system has been commissioned by a Johnson Controls authorized representative.
- Any adjustments to the operating pressure settings of the fire sprinkler air maintenance device(s) or the nitrogen generator will have an adverse effect on the nitrogen inerting process and could damage the nitrogen generation equipment.
- **Any changes to the fire sprinkler air maintenance device(s) or nitrogen generator operating pressure settings must be authorized by and performed under the direction of Johnson Controls.**

Sprinkler System Gauge Accuracy

The accuracy of the gauges used in fire sprinkler systems can affect the operating pressure of the fire sprinkler system as well as determining the required 3-5 psig (.2-.3 bar) pressure range needed to properly remove the oxygen from a fire sprinkler system. NFPA 25 indicates that gauges in excess of $\pm 3\%$ must be replaced or recalibrated. FM Global allows the gauges used in fire sprinkler systems to be accurate within $\pm 2\%$ over the center third of its scale and $\pm 3\%$ over the remaining two-thirds of its scale. This can become paramount when operating a low-pressure valve sprinkler system with an operating pressure of 15-20 psig (1-1.4 bar).

Example: NFPA 25 – A 200 psi (14 bar) gauge with $\pm 3\%$ accuracy equates to ± 6 psi (.4 bar) variance in the actual pressure reading of the gauge. Therefore, a sprinkler system indicating a 40 psig (2.8 bar) operating pressure can actually be operating between 34 psig (2.3 bar) and 46 psig (3.2 bar).

FM Global – A 200 (14 bar) psi gauge with $\pm 2\%$ accuracy in the center third of the gauge equates to ± 4 psi (.3 bar) variance in the actual pressure reading of the gauge; and $\pm 3\%$ accuracy in the upper and lower third of the gauge equates to ± 6 psi (.4 bar) variance in the actual pressure reading of the gauge.

- A 200 psi (14 bar) gauge on a sprinkler system indicating a 100 psig (6.9 bar) (center third of the gauge) operating pressure can actually be operating between 96 psig (6.6 bar) and 104 psig (7.2 bar).

- A 200 psi (14 bar) gauge on a sprinkler system indicating a 20 psig (1.4 bar) (lower third of the gauge) operating pressure can actually be operating between 14 psig (.9 bar) and 26 psig (1.8 bar).

A sprinkler system using a low-pressure valve with a 200 psi (14 bar) gauge indicating a 15 psig (1 bar) operating pressure can actually be operating between 9 psig (.6 bar) and 21 psig (1.4 bar); which could be close to the low-air alarm/trip pressure of the sprinkler system.

The digital controller in the TYCO Nitrogen Generator used to turn-on and turn-off the nitrogen generator is accurate to $< \pm 1.5\%$.

To ensure proper operation of the sprinkler system and the nitrogen generator, calibrate the sprinkler system operating pressure to the turn-on pressure of the nitrogen generator using the Air Maintenance Device (AMD) Pressure Adjustment Procedure in the Maintenance Section of this manual.

The procedure aligns the sprinkler system operating pressure to the turn-on pressure of the nitrogen generator; reducing the potential of the nitrogen generator turn-on pressure to be set near the low-air alarm/trip pressure of the sprinkler system.

Sprinkler System Air Maintenance Device

Dry-pipe/pre-action fire sprinkler systems are to be configured to use a single air maintenance device (AMD) for each dry-pipe/pre-action fire sprinkler system in accordance with NFPA 13.

- Applications where multiple fire sprinkler systems are served with a single AMD has been known to cause nitrogen generators to short cycle due to the air restriction that the AMD imposes on the nitrogen supply line. Short cycling of the nitrogen generator can cause damage to the system components and may affect the manufacturer's warranty.

AMD operation is directly affected by the inlet pressure to the AMD. To ensure the AMD operates properly with the nitrogen generator, use the Air Maintenance Device (AMD) Pressure Adjustment Procedure in the Maintenance Section of this manual.

Fire Sprinkler System Leak Rates

The leak rate of a dry pipe or preaction fire sprinkler system will have direct effect on the nitrogen generator run frequency or on/off cycles. The maximum allowable leak rate in a fire sprinkler system as defined by NFPA-13 is 1.5 psig (.1 bar) within a 24-hour period. The design specifications of TYCO Nitrogen Generators is based on 3.0 psig (.2 bar) leak rate within a 24-hour period. Sprinkler systems with a leak rate in excess of 3.0 psig (.2 bar) within a 24-hour period will cause the nitrogen generator run frequency to increase resulting in a greater wear on system components and a potential reduction in the service life of the nitrogen generator. Sprinkler systems with a leak rate greater than 3.0 psig (.2 bar) in 24-hours must be repaired to ensure the anticipated service life of the nitrogen generator is met.

NOTES: The run frequency of the nitrogen generator in this chart is based on nitrogen generator operation outside of the 14-day nitrogen inerting process with the vent closed.

Excessive cycle count could indicate an air compressor/nitrogen generator short cycling issue. Contact Johnson Controls before proceeding – visit the CONTACT US page at www.tyco-fire.com for the contact information by location.

Sprinkler Leak Rate to TYCO Nitrogen Generator Run Cycle Comparison							
Leak Rate psig (bar)/24 Hr	Generator Cycle Time Time between cycles Hrs.	Cycles per Day	Cycles per Week	Leak Rate psig (bar)/24 Hr	Generator Cycle Time Time between cycles Hrs.	Cycles per Day	Cycles per Week
1.5 (.10) *	80	< 1	3	15.0 (1.0)	8	3	21
2.0 (.14)	60	< 1	3	15.5 (1.1)	7.7	4	22
2.5 (.17)	48	< 1	4	16.0 (1.1)	7.5	4	23
3.0 (.20) ***	40	< 1	5	16.5 (1.2)	7.3	4	23
3.5 (.24)	34.3	< 1	5	17.0 (1.2)	7.1	4	24
4.0 (.28)	30	< 1	6	17.5 (1.2)	6.9	4	25
4.5 (.31)	26.7	< 1	7	18.0 (1.2)	6.7	4	25
5.0 (.35)	24	1	7	18.5 (1.3)	6.6	4	26
5.5 (.38)	21.8	2	8	19.0 (1.3)	6.3	4	27
6.0 (.41)	20	2	9	19.5 (1.3)	6.2	4	27
6.5 (.45)	18.5	2	9	20 (1.4)	6	4	28
7.0 (.48)	17.1	2	10	21 (1.4)	5.7	5	30
7.5 (.52)	16	2	11	22 (1.5)	5.5	5	31
8.0 (.55)	15	2	12	23 (1.6)	5.2	5	33
8.5 (.59)	14.1	2	12	24 (1.7)	5	5	34
9.0 (.62)	13.3	2	13	25 (1.7)	4.8	5	35
9.5 (.66)	12.6	2	14	26 (1.8)	4.6	6	37
10.0 (.69)	12	2	14	27 (1.9)	4.5	6	38
10.5 (.72)	11.4	3	15	28 (1.9)	4.3	6	39
11.0 (.76)	10.9	3	16	29 (2.0)	4.2	6	40
11.5 (.79)	10.4	3	17	30 (2.1)	4	6	42
12.0 (.83)	10	3	17	31 (2.1)	3.9	7	43
12.5 (.86)	9.6	3	18	32 (2.2)	3.8	7	45
13.0 (.90)	9.2	3	19	33 (2.3)	3.7	7	46
13.5 (.93)	8.9	3	19	34 (2.3)	3.6	7	47
14.0 (.97)	8.6	3	20	35 (2.4)	3.5	7	48
14.5 (1.0)	8.3	3	21	36 (2.5) **	3.4	8	50

* NFPA-13 Allowable leak rate.

** NFPA-25 Allowable leak rate.

*** Allowable leak rate for TYCO Nitrogen Generators. Higher leak rates may reduce the service life of the nitrogen generator.

Start-Up and Operation Procedures

Installation Instructions

Installation of the TYCO Nitrogen Generator requires five (5) steps:

1. Mount the cabinet in the appropriate location
2. Connect the dedicated power supply to the cabinet
3. Plumb the nitrogen/air supply line to the dry/preaction sprinkler risers being served with minimum ½" line
4. Plumb the condensate drain line to floor drain or building exterior
5. Connect nitrogen generator output signals to BMS or fire alarm system, where applicable

Wire Gauge Chart

1. Ensure an appropriately rated disconnect switch and circuit breaker are installed in a suitable and accessible location in accordance with the *National Electrical Code (NFAP-70)*.
2. The circuit breaker and disconnect are to be easily identifiable as associated with the equipment.
3. Ensure the ground wire is properly connected to the ground terminal(s) of the equipment using appropriately sized ground wire.

Wire Gauge Chart							
Size (AWG)	Amperage			Diameter		Resistance	
	60° C (140° F)	75° C (167° F)	90° C (194° F)	(Inches)	(mm)	(Ohms / 1,000 ft)	(Ohms / km)
14	15	15	15	.0641	1.6281	2.525	8.282
12	20	20	20	.0808	2.0523	1.588	5.2086
10	30	30	30	.1019	2.5883	.9989	3.27639
8	36	43	48	.1285	3.2639	.6282	2.06050

Step 1: Mounting the nitrogen generator cabinet

The TYCO Nitrogen Generator is designed to be mounted directly to the wall at the appropriate location. Several factors should be considered in choosing the proper mounting location for the nitrogen generator:

- Access to required power supply (dedicated circuit)
- Access to sprinkler risers being supplied from nitrogen generator
- Access to drain for the condensate discharge line
- Clearance in front of the unit to open the cabinet door and for servicing the equipment
- Cleanliness of the environment and air intake

CAUTION: Nitrogen generator cabinet includes ventilation vents in the bottom and side. Ensure that all ventilation vents are not blocked to allow proper ventilation throughout the nitrogen generator cabinet.

The cabinet includes a wall mounting bracket with pre-punched holes using standard anchors.

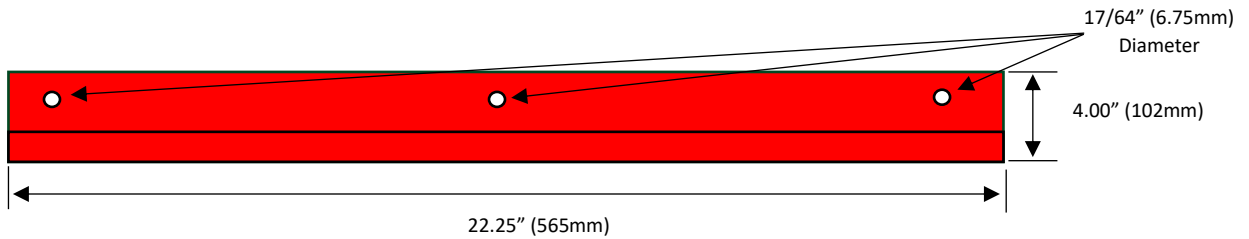

Figure 1a

NOTE: Ensure the wall is structurally sound and the cabinet is firmly anchored to a wall to support the generator cabinet

The cabinet includes anchoring holes in the lower left and lower right corners of the cabinet using standard anchors (See Figure 1b).

NOTE: Johnson Controls recommends that the nitrogen generator be anchored to the wall using the wall mounting bracket and the anchoring holes in the nitrogen generator cabinet.

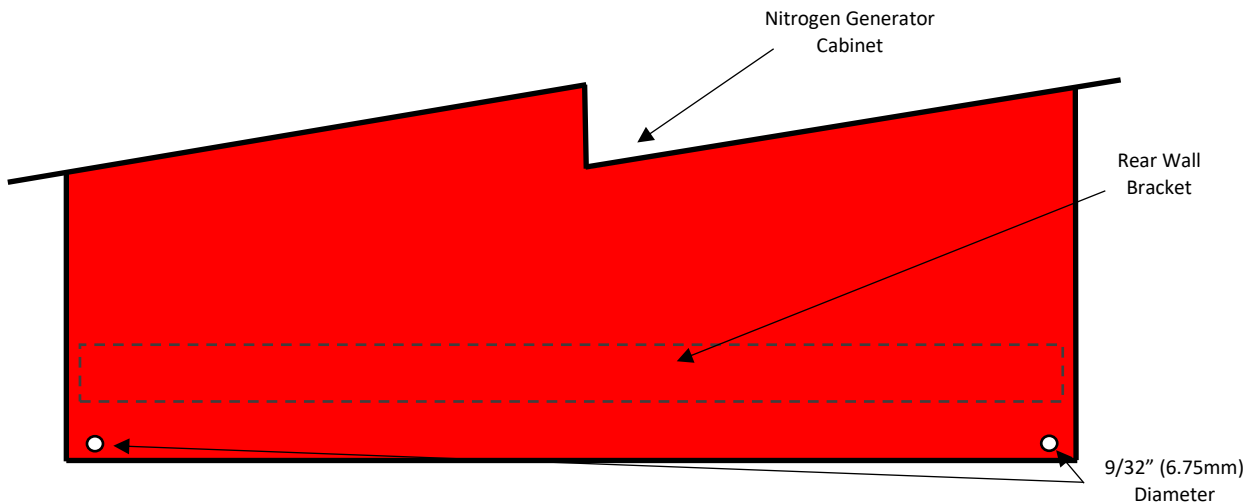

Figure 1b

Step 2: Power Supply

The TYCO Nitrogen Generator requires a dedicated power supply to prevent interaction with other equipment. The incoming power supply line is connected to the top of the terminal blocks inside the nitrogen generator cabinet. The terminal connections are labeled L1, N, and G.

Required nitrogen generator power supply: 120v/1 phase/60Hz (230v/1 phase/50Hz) dedicated 20 amp circuit.

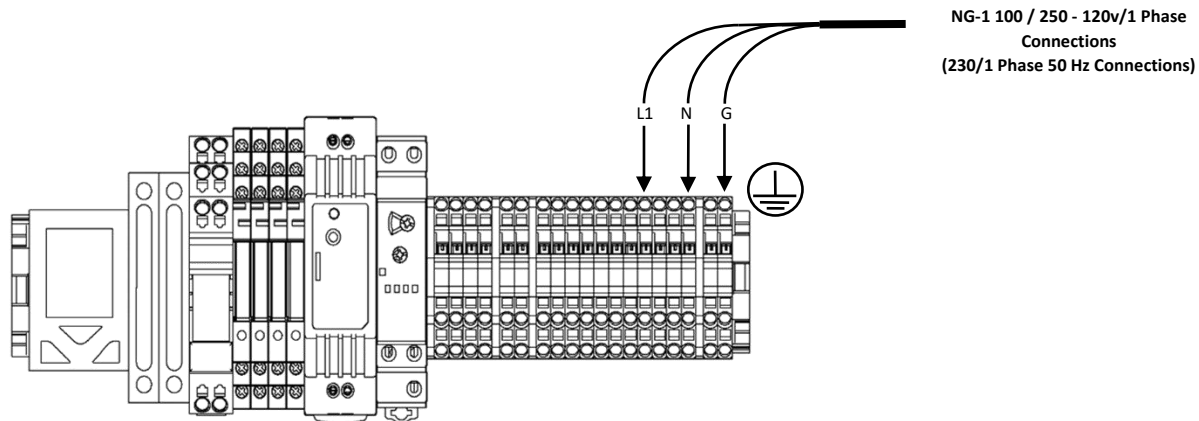

Figure 2

Step 3a: Plumb the Nitrogen/Air Supply Line – No Additional Air Compressor (Figure 3a)

The nitrogen/air discharge plumbing from the TYCO Nitrogen Generator must be connected directly to the dry or preaction valve trim using a minimum ½” black steel, galvanized steel, or copper lines. The size of the nitrogen/air supply line must be based on both the length of pipe between the nitrogen generator and fire sprinkler systems and the total volume of fire sprinkler systems being supplied.

NOTE: The TYCO Nitrogen Generator requires an in-line Air Maintenance Device (AMD) such as the TYCO AMD-1 which is equipped with an on-board field adjustable pressure regulator for each sprinkler system being served.

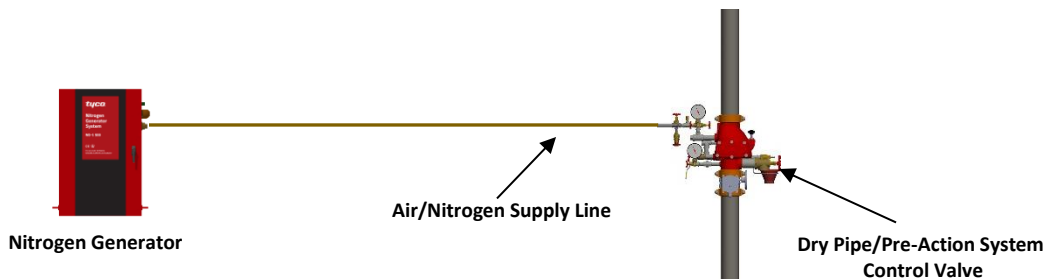

Figure 3a

Step 3b: Plumb the Nitrogen/Air Supply Line – With Separate Air Compressor (Figure 3b)

A separate air compressor can be used to meet the NFPA 13 30-minute fill requirement or as a back up to the nitrogen generator. In this application, the nitrogen/air discharge plumbing from the TYCO Nitrogen Generator and the separate air compressor are connected to the dry or preaction valve trim with isolation valves in each supply line using a minimum ½” black steel, galvanized steel, or copper lines. The size of the nitrogen/air supply line must be based on both the length of pipe between the nitrogen generator and fire sprinkler systems and the total volume of fire sprinkler systems being supplied.

NOTE: The TYCO Nitrogen Generator requires an in-line Air Maintenance Device (AMD) such as the TYCO AMD-1 which is equipped with an on-board field adjustable pressure regulator for each sprinkler system being served.

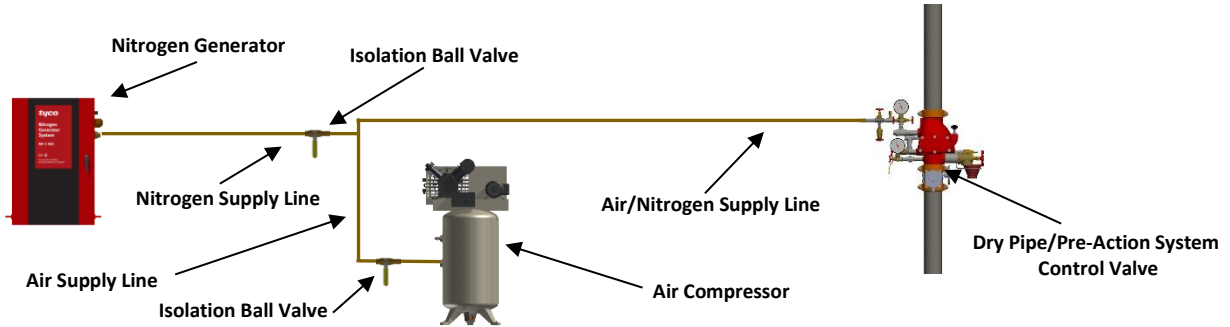

Figure 3b

Step 3c: Plumb the Nitrogen/Air Supply Line – With House/Plant Air Supply (Figure 3c)

A separate house/plant air supply can be used as a back up to the nitrogen generator. In this application, the nitrogen/air discharge plumbing from the TYCO Nitrogen Generator and the separate hose/plant air supply are connected to the dry or preaction valve trim with isolation ball valves in each supply line using a minimum ½” black steel, galvanized steel, or copper lines. The size of the nitrogen/air supply line must be based on both the length of pipe between the nitrogen generator and fire sprinkler systems and the total volume of fire sprinkler systems being supplied.

NOTE: The TYCO Nitrogen Generator requires an in-line Air Maintenance Device (AMD) such as the TYCO AMD-1 which is equipped with an on-board field adjustable pressure regulator for each sprinkler system being served.

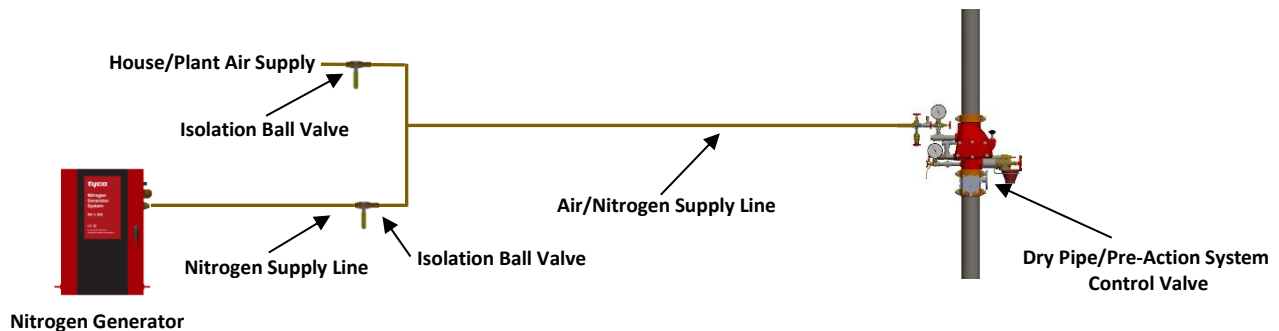

Figure 3c

Step 4: Plumb the Condensate Drain Line

The TYCO Nitrogen Generator will occasionally discharge a small amount of condensate water from the coalescing filters inside the cabinet. It is recommended that the ¼" drain connection be plumbed to a floor drain or building exterior. When plumbing to a drain is not feasible an evaporative collection chamber can be used.

Step 5: System Signals and Monitoring, where used

The nitrogen generator cabinet has two (2) system signals and five (5) outputs that can be monitored by the facility's BMS or fire alarm system.

Two (2) system signals:

- Bypass Alarm - The nitrogen generator operating in the bypass mode which is activated when the bypass valve is in the "fast fill" position to fill the fire sprinkler system and the air supplied directly from the air compressor has reached a pressure of 20 psig (1.4 bar). (Flashing amber light)
- Leak Monitor - The nitrogen generator is equipped with a leak monitor audible signal which is activated when the nitrogen generator runs excessively. (Audible signal)

Five (5) system output signals for monitoring through a building monitoring system, if desired:

- Nitrogen Generator Running Mode - Form C Contacts (Energized, LED On When Running)
- Bypass Mode Alarm - Form C Contacts (Normally De-Energized, LED Off)
- Nitrogen Generator Loss of Power - Form C Contacts (Normally Energized, LED On)
- Leak Monitoring - Form C Contacts (Normally De-Energized, LED Off)
- Nitrogen System Supply Line Pressure - Analog Signal

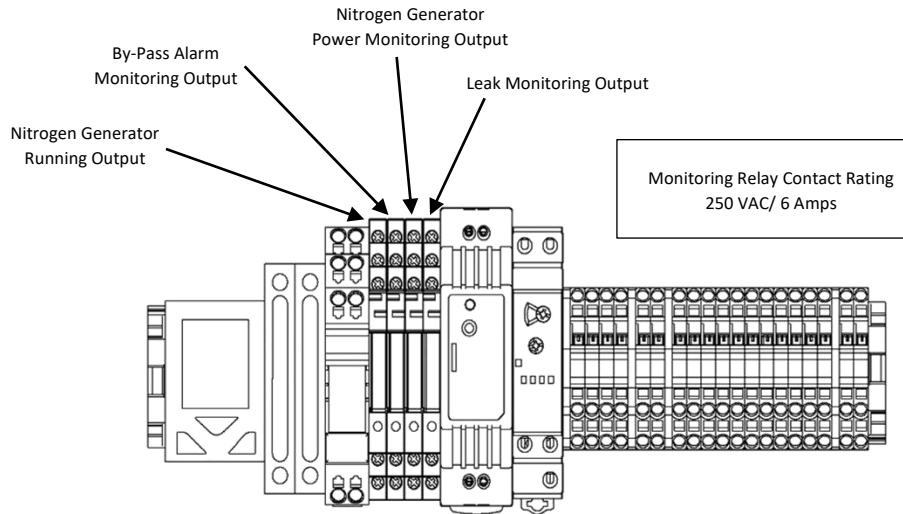
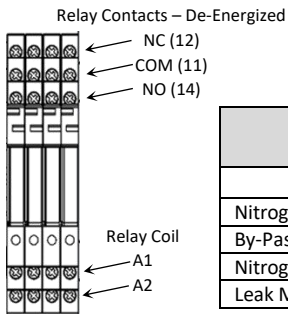

Figure 5



Description	Normally Open Contact Connections (i.e. Fire Alarm)			Normally Closed Contact Connection (i.e. B.A.S.)		
	Relay	LED	Connections	Relay	LED	Connections
Nitrogen Generator Running Output (Running)	Energized	On	11&12	Energized	On	11&14
By-Pass Alarm Monitoring Output	De-Energized	Off	11&14	De-Energized	Off	11&12
Nitrogen Generator Power Monitoring Output	Energized	On	11&12	Energized	On	11&14
Leak Monitoring Output	De-Energized	Off	11&14	De-Energized	Off	11&12

Start-Up Procedure

Only a certified Johnson Controls representative should commission the new equipment into service once it is installed. **Once the nitrogen generator has been configured, there should be no reason for re-adjusting.** To start-up the generator or to put back in service, follow these steps:

NOTE: For component locations, see Generator Configuration Diagram - Maintenance Section.

1. Verify the air maintenance devices (AMDs) have been set to the system operating or “high end” breathing pressure.
 - a. Ensure AMD is calibrated to operate with nitrogen generator pressures using the Air Maintenance Device (AMD) Pressure Adjustment Procedure in the Maintenance Section of this manual.
2. **Important** - Verify the nitrogen generator turn-on pressure is 3-5 psig (.2-.3 bar) psig **below** the air maintenance device set pressure.
3. **Important** - Verify the nitrogen generator turn-on pressure is 3-5 psig (.2-.3 bar) psig **above** the low air alarm set pressure.
4. Verify the nitrogen generation/air bypass valve is nitrogen generation position.*
* The only time the nitrogen generation/air bypass valve should need to be in the “air bypass” position is for the NFPA 13 30-min system fill time requirement
5. Turn the cabinet power switch ON. The generator will begin filling the system with nitrogen.

NOTE: The nitrogen generator incorporates an 8-second delay upon nitrogen generator start for protection of the integral air compressor.

System Filling Procedure

The sprinkler system(s) can be filled using one of two filling methods based on whether the integral air compressor of the nitrogen generator can meet the NFPA 13 30-minute fill requirement.

- Filling with Integral Air Compressor - When the sprinkler system size is within the limitations of the nitrogen generator’s integral air compressor.
- Filling with Separate Air Compressor - When the sprinkler system size exceeds the nitrogen generator’s integral air compressor limitations.

1. Filling with Integral Air Compressor
 - a. Turn the nitrogen generation/air bypass valve to the “air bypass” position.
NOTE: Bypass Alarm indicator will flash.
 - b. Open the fast fill valve and close the regulated valve of all appropriate air maintenance devices (AMDs) necessary to fill the sprinkler system(s).
 - c. Close the fast fill and regulated AMD valves on any system not being filled.
 - d. Start the nitrogen generator.
 - e. Once the sprinkler system(s) obtain the desired pressure:
 - i. Turn the nitrogen generation/air bypass valve to the “nitrogen generation” position.

NOTE: Bypass Alarm indicator will turn off.

- ii. Close the AMD fast fill valve and open the AMD regulated valve.
 - iii. Open AMD regulated valves that were previously closed on any systems not being filled.
 - f. Initiate the fourteen (14) day nitrogen inerting process (See Nitrogen Inerting Process).
 - g. Once the nitrogen inerting process is completed, the TYCO nitrogen generator will continue to automatically operate when any of the associated sprinkler systems require nitrogen.
2. Filling with Separate Air Compressor
- a. Close the nitrogen supply line ball valve from the nitrogen generator.
 - b. Open the air supply ball valve from the separate air compressor.
 - c. Open the fast fill valve and close the regulated valve of all appropriate air maintenance device (AMD)'s necessary to fill the sprinkler system(s).
 - d. Close the fast fill and regulated AMD valves on any system not being filled.
 - e. Once the sprinkler system(s) obtain the desired pressure:
 - i. Close the air supply ball valve from the separate air compressor.
 - ii. Open the nitrogen supply line ball valve from the nitrogen generator.
 - iii. Close the AMD's fast fill valve and open the AMD's regulated valve.
 - iv. Open regulated valve AMD's on any system not being filled that were previously closed.
 - f. Initiate the nitrogen inerting process - Open the valve on the TYCO Manual Vent or depress "Vent" pushbutton on the TYCO SMART Vent to initiate the fourteen (14) day nitrogen inerting process.
 - g. Completion of nitrogen inerting process - Close the valve on the TYCO Manual Vent or the TYCO SMART Vent will automatically close at the completion of the fourteen (14) day nitrogen inerting process.
 - h. The TYCO nitrogen generator will continue to automatically operate when any of the associated sprinkler systems require nitrogen.

Nitrogen Inerting Process

- 1. Manual Vents
 - a. Open the ball valve on the TYCO Manual Vent to initiate the fourteen (14) day nitrogen inerting process.
 - b. Close the ball valve on the TYCO Manual Vent at the completion of the fourteen (14) day nitrogen inerting process.
- 2. SMART Vents
 - a. Depress the "Vent" pushbutton on the TYCO SMART Vent Controller which energizes the solenoid on the SMART Vent to initiate the fourteen (14) day nitrogen inerting process.
 - b. At the completion of the fourteen (14) day nitrogen inerting process the SMART Vent Controller will automatically close the vent by de-energizing the solenoid.

Normal Operation

Once in service, the nitrogen generator requires no additional intervention to function properly. Generator settings should not be altered without first consulting with Johnson Controls and the unit should not be powered down for any reason other than maintenance. To take the generator out of service for maintenance, follow these steps:

1. Close the AMD regulated and fast fill valve on the appropriate fire sprinkler system.
2. Power off generator cabinet.

Fire Sprinkler System Maintenance Procedure

In the event the fire sprinkler system requires maintenance or repair, the following procedure ensures the nitrogen inerting process will continue to function properly.

1. Close the AMD regulated and fast fill valve on the appropriate fire sprinkler system.
2. Depressurize the fire sprinkler system.
3. Complete the maintenance or repair work on the fire sprinkler system.
4. Open the appropriate fire sprinkler system AMD to pressurize the appropriate fire sprinkler system (See System Filling Procedure).

Sequence of Operation

Once in service, the nitrogen generator requires no additional intervention to function properly. Generator settings should not be altered without consulting with Johnson Controls and the unit should not be powered down or bypassed for any reason other than a service or maintenance procedure as detailed in the Maintenance Section. The nitrogen generator operates in two (2) modes, Nitrogen Inerting Mode and Supervisory Gas Mode.

NOTE: The nitrogen generator incorporates an 8-second delay upon nitrogen generator start for protection of the integral air compressor.

Nitrogen Inerting Mode

The application of supervisory nitrogen gas to a dry or preaction fire sprinkler system using the TYCO Dry Pipe Nitrogen Inerting (DPNI) protocol is fundamentally different than the traditional application of compressed air as a supervisory gas. Because the DPNI protocol uses a process called “fill and purge breathing” it requires small (3-5 psig (.2-.3 bar)) supervisory pressure fluctuations in the fire protection system(s) to remove oxygen before it can cause corrosion.

- The nitrogen generator and compressor will cycle on to increase the pressure in all fire protection systems connected to the nitrogen generator.
- Once the high-end pressure of the breathing cycle is reached the air compressor and nitrogen generator will turn off and the fire protection system(s) are allowed to depressurize gradually through the oxygen removal vent(s).
- Once the low-end pressure of the breathing cycle is reached, the air compressor and nitrogen generator automatically turn on to repeat the process.
- The high-end/turn-off pressure is determined by the pressure setting of the fire sprinkler system(s) air maintenance device (AMD) and the low-end/turn-on pressure is determined by the nitrogen generator’s integral pressure transducer.
- The air compressor and nitrogen generator are simultaneously cycling the pressure in all fire protection system(s) by 3-5 psig (.2-.3 bar) during each cycle. This will result in longer run times of the air compressor and nitrogen generator than a traditional air compressor configured to supply supervisory gas.
- The DPNI “fill and purge breathing” protocol described above is performed for a fourteen (14) day period, during this time the system pressure will fluctuate between the high-end and low-end breathing pressures.
- Once the fourteen (14) day period is complete and the ball valve on the manual vent is closed or the SMART vent is automatically closed; and the run frequency of the air compressor and nitrogen generator is reduced.
- It is important to remember that closing the vents will not affect the runtime of the air compressor and nitrogen generator. It will only affect the frequency that the air compressor and nitrogen generator will run. The nitrogen generator and air compressor are designed to run for up to four (4) hours at a time when filling all the systems with 3-5 psig (.2-.3 bar) of high purity nitrogen. If air compressor and nitrogen generator runtimes are greater than four (4) hours, contact Johnson Controls.

TYCO Nitrogen Generator Pressure Cycling for Dry and Preaction Fire Sprinkler Systems

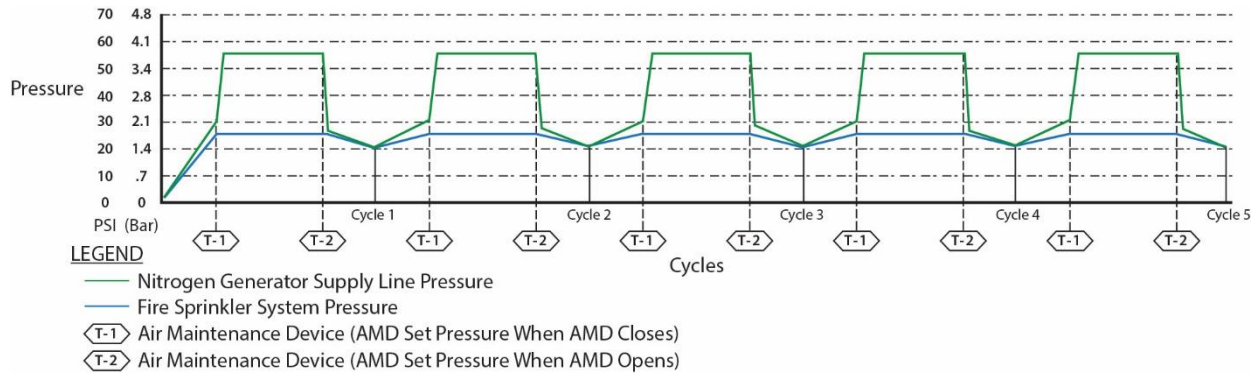

OPERATING NOTES:

1. The nitrogen generator produces nitrogen increasing the pressure in the nitrogen supply line which increases the pressure in the fire sprinkler system.
2. When the pressure in the fire sprinkler system reaches the pressure setting of the Air Maintenance Device (AMD), the AMD closes (no longer needing supervisory gas).
3. The nitrogen generator continues to produce nitrogen increasing the pressure in the nitrogen supply line until the cut-out pressure is reached and the nitrogen generator shuts off.
4. When the pressure in the fire sprinkler system decreases (inerting process or normal operation) below the pressure of the AMD, the AMD opens (needing supervisory gas).
5. The pressure in the nitrogen supply line equalizes with the pressure in the fire sprinkler system.
6. When the pressure in the nitrogen supply line and the fire sprinkler system decreases to the cut-in pressure of the nitrogen generator, the nitrogen generator turns on.
7. The nitrogen generator produces nitrogen increasing the pressure in the nitrogen supply line and the fire sprinkler system, repeating the nitrogen filling cycle.
8. The nitrogen inerting "fill & purge" process requires a 3-5 psig (.2-.3 bar) range between the cut-in pressure of the nitrogen generator and the pressure of the AMD to nitrogen inert the fire sprinkler system within 14 days.

GRAPH NOTE:

The pressures reflected in the graph are representative of the operating pressures in a typical dry pipe or pre-action fire sprinkler system. Actual operating pressures may vary.

Supervisory Gas Mode

Once the DPNI “fill and purge breathing” protocol is complete the nitrogen generator will automatically operate in the Supervisory Gas Mode. Whenever a fire protection system needs supervisory gas the nitrogen generator and compressor will automatically operate.

- The vents no longer operate to depressurize the systems.
- When the sprinkler systems reach the low-end pressure, the nitrogen generator and compressor will automatically turn on to increase the pressure in all fire protection systems connected to the nitrogen generator.
- Once the high-end pressure of the breathing cycle is reached the air compressor and nitrogen generator will automatically turn off.
- It is important to remember that closing the vents will not affect the *runtime* of the air compressor and nitrogen generator it will only affect the *frequency* of the runtime of the air compressor and nitrogen generator. The nitrogen generator and air compressor are designed to run for up to four (4) hours at a time when filling all the systems with 3-5 psig (.2-.3 bar) of high purity nitrogen.
- If air compressor and nitrogen generator runtimes are greater than four (4) hours, contact Johnson Controls.

Restart of the Nitrogen Inerting Process

Whenever the fire sprinkler system(s) are serviced and refilled with air, the TYCO DPNI protocol using the “fill and purge breathing” process must be reinitialized.

- Manual Vent:
 - Open the manual vent isolation ball valve to begin the venting process.
 - The isolation ball valve on the manual vent(s) will need to be closed after fourteen (14) days to stop the Nitrogen Inerting Mode and begin the Supervisory Gas Mode.
- SMART Vent:
 - Depress the “Vent” button on the SMART Vent control box which energizes the solenoid on the SMART Vent to begin the venting process.
 - The SMART Vent(s) will automatically close at the end of the fourteen (14) inerting period and the nitrogen generator and compressor will automatically transition from the Nitrogen Inerting Mode to the Supervisory Gas Mode.

System Power Loss

In the event of a system power loss, all programmed information in the nitrogen generator is stored in the nitrogen generator and the nitrogen generator will automatically restart once system power is restored.

- Where manual vents are installed, the system will automatically return to Nitrogen Inerting Mode or Supervisory Gas Mode, depending on which mode the nitrogen generator was in when the power loss occurred.
 - If manual vent ball valve is open (Nitrogen Inerting Mode), then the ball valve needs to be manually closed upon completion of the fourteen (14) day DPNI process. The air compressor and nitrogen generator will automatically transition to the Gas Supervisory Mode.
- Where SMART vents are installed, the system will automatically return to the Supervisory Gas Mode. When the system power loss is during the fourteen (14) day DPNI process, the DPNI process will need to be reinitialized.
 - Depress the “Vent” button on the SMART vent control box which energizes the solenoid on the SMART vent.
 - The nitrogen generator and compressor will automatically cycle on operating in the nitrogen inerting mode.
 - Upon completion of the fourteen (14) day DPNI process, the vents automatically close and the air compressor and nitrogen generator will automatically transition to the Gas Supervisory Mode.

Oxygen Removal Vent - TAV-D & TSV-D

TYCO Manual Vent - TAV-D



For use under U.S. Patents
8,720,591, 9,144,700, 9,186,533 and 9,610,466 B2

Specifications

Model Number:	TAV-D
Service Pressure:	Up to 175 PSIG (12 Bar)
System Connection:	1" NPT Male
Temperature Range:	40°F to 120°F (4.5°C to 49°C)
Dimensions:	13.5"(W) X 4.25"(D) X 7.5"(H) (343mm (W) X 108mm (D) X 191mm (H))

Support Hanger Not Required

General Description

The TYCO Manual Vent provides oxygen venting in dry pipe fire sprinkler systems. The restricted venting orifice allows oxygen to be vented from the fire sprinkler system at a controlled rate to achieve a minimum nitrogen concentration of 98%. The TYCO Manual Vent is equipped with a levered float valve that allows gas to discharge but prevents liquid water from leaking through the restricted venting orifice in the event water enters the fire sprinkler system. A backpressure regulator is also included to prevent total system depressurization from the vent assembly. A special fitting is provided to receive 5/32" tubing when the vent is used in conjunction with the TYCO SMART Gas Analyzer.

Installation Instructions

1. The TYCO Manual Vent is equipped with a ball valve to be connected to the fire sprinkler riser. The contractor must install a 1" outlet (welded or mechanical) to connect the vent assembly to the sprinkler system on the system side of the main control valve. The ball valve must remain in the closed position until the TYCO Nitrogen Generator System has been commissioned.

NOTE: The vent assembly does not require a support hanger.

2. Install the vent assembly in a level position. Recommended mounting height is 5'-10' (1.5-3m) above the finished floor.

NOTE: Piping to the vent assembly cannot be installed in a configuration that would trap water and prevent drainage to the sprinkler system; a water trap impedes the ability of the vent assembly to vent oxygen from the fire sprinkler system.

3. Inspection of the vent assembly should be performed after installation and hydrostatic testing of the fire sprinkler system. Inspection should be performed periodically thereafter in accordance with the applicable NFPA codes and standards, and/or the authority having jurisdiction.

NOTE: Inspection must include the condition of the in-line filter and checking for blockage in the “Y” strainer and the restricted venting orifice.

Operating Instructions

1. Verify the vent assembly has been equipped with a restricted venting orifice downstream of the backpressure regulator.

NOTE: If the vent assembly is not equipped with a restricted venting orifice, one will be provided by Johnson Controls during system commissioning. The restricted venting orifice must be installed before proceeding with the steps below.

2. Determine the low air alarm pressure and normal operating pressure of the fire sprinkler system
3. Choose a pressure setting for the backpressure regulator that is 3-5 psig (.2-.3 bar) above the low air alarm pressure but below the normal operating pressure of the fire sprinkler system
4. Pull the knob out from the regulator to adjust pressure setting. Turn the knob clockwise to raise the pressure, counter-clockwise to lower the pressure.
5. Close the ball valve and allow device to depressurize through restricted venting orifice to pressure setting. Make adjustment to pressure setting using the knob, then open ball valve to pressurize device and close ball valve again to check pressure setting. Repeat process until desired pressure setting is achieved.

NOTE: This process can only be performed when fire sprinkler system is at normal operating pressure.

6. Push knob back into regulator until it clicks into place.
7. Once the TYCO Nitrogen Generator System has been commissioned, open the isolation ball valve on the vent assembly. The TYCO Manual Vent is now open and actively venting oxygen from the fire sprinkler system. It should remain open for approximately 14 days or less, until the system nitrogen concentration reaches 98% or greater. Use a TYCO Handheld Gas Analyzer to verify the gas concentration inside the fire sprinkler system.
8. Close the isolation ball valve. Failure to close the manual ball valve after fourteen (14) days or less, once fire sprinkler system nitrogen concentration reaches 98% will result in additional oxygen corrosion damage to the system and unnecessary run time of the air compressor and nitrogen generator.
9. If the sprinkler system actuates or another event introduces oxygen to the sprinkler system the manual ball valve must be opened again for a period of fourteen (14) days to vent oxygen from the system.

TYCO Manual Vent Components

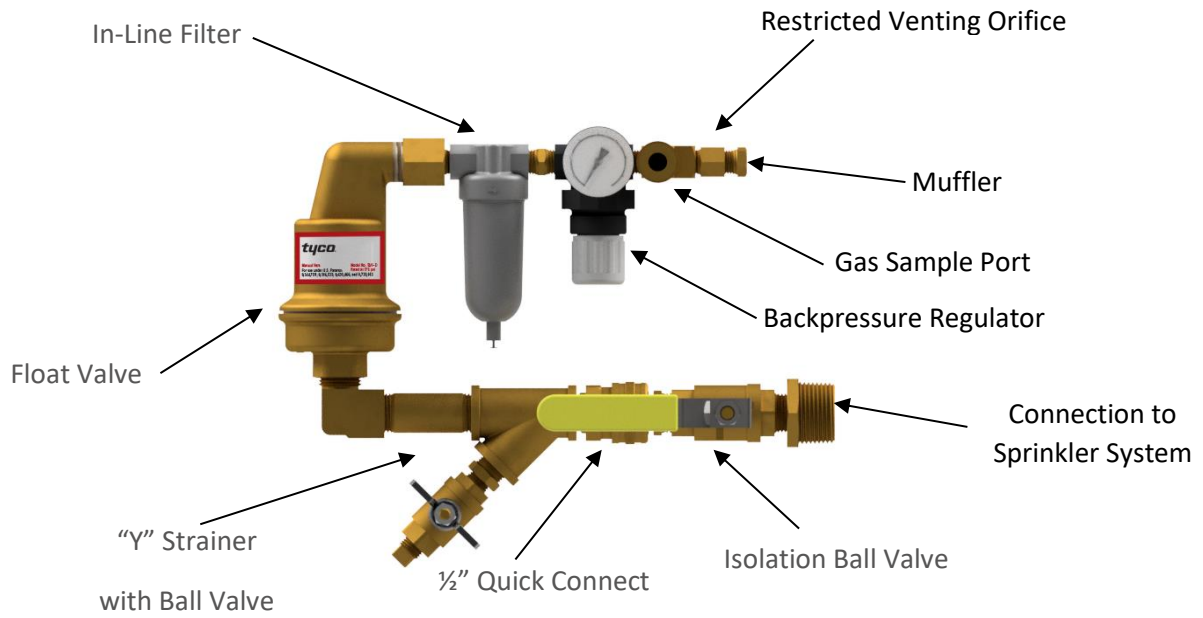

TYCO Manual Vent Installation Schematic

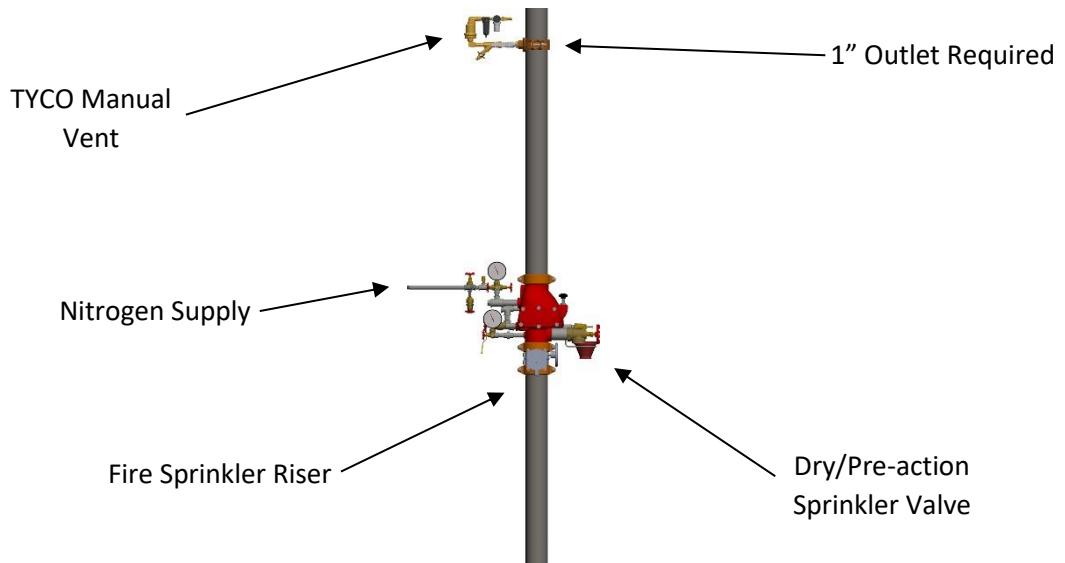

TYCO SMART Vent - TSV-D

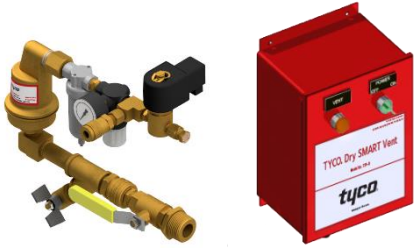

For use under U.S. Patents
8,720,591, 9,144,700, 9,186,533 and 9,610,466

Specifications

Model Number:	TSV-D
Service Pressure:	Up to 175 PSIG (12 Bar)
System Connection:	1" NPT Male
Temperature Range:	40°F to 120°F (4.5°C to 49°C)
Dimensions:	
Vent Assembly:	13.5"(W) X 4.25"(D) X 7.5"(H) (343mm (W) X 108mm (D) X 191mm (H))
Control Box:	9"(W) X 7"(D) X 10"(H) (229mm (W) X 178mm (D) X 254mm (H))

Support Hanger Not Required

General Description

The TYCO SMART Dry Vent provides automatic oxygen venting in dry pipe fire sprinkler systems. The restricted venting orifice allows oxygen to be vented from the fire sprinkler system at a controlled rate to achieve a minimum nitrogen concentration of 98%. The TYCO SMART Dry Vent is equipped with a levered float valve that allows gas to discharge but prevents liquid water from leaking through the restricted venting orifice in the event water enters the fire sprinkler system. A backpressure regulator is also included to prevent total system depressurization from the vent assembly. A special fitting is provided to receive 5/32" tubing when the vent is used in conjunction with the TYCO SMART Gas Analyzer.

The TYCO SMART Dry Vent is equipped with an electronic solenoid valve that must be wired to the electric control box (conductors not included). The control box will automatically close the vent once the desired nitrogen concentration has been reached. The control box is equipped with an on/off switch and a vent button to provide a means to restart of the venting process should oxygen be reintroduced into the fire sprinkler system.

Installation Instructions

1. The TYCO SMART Dry Vent includes two (2) separate components. The first component is the vent assembly equipped with a ball valve to be connected to the fire sprinkler riser. The contractor must install a 1" outlet (welded or mechanical) to connect the vent assembly to the sprinkler system on the system side of the main control valve. The isolation ball valve must remain in the closed position until the TYCO Nitrogen Generator System has been commissioned.

NOTE: The vent assembly does not require a support hanger.

2. Install the vent assembly in a level position. Recommended mounting height is 5'-10' (1.5-3m) above the finished floor.

NOTE: Piping to the vent assembly cannot be installed in a configuration that would trap water and prevent drainage to the sprinkler system; a water trap impedes the ability of the vent assembly to vent oxygen from the fire sprinkler system.

3. The second component of the TYCO SMART Dry Vent is the electric control box. The control box must be installed on a wall or vertical surface adjacent to the vent assembly installation location.
4. Provide conductors from 120VAC/60Hz (230VAC/50Hz) power supply to designated terminals in the electric control box in accordance with the National Electrical Code (NFPA 70) and any local requirements. The device draws less than 2 amps. Contractor must drill hole in the control box to provide access for the 120VAC/60Hz (230VAC/50Hz) power supply conductors.
5. Provide conductors to connect the 120VAC/60Hz (24VDC) coil leads of the electronic solenoid valve on the vent assembly to the designated terminals in the electric control box in accordance with the National Electrical Code (NFPA 70) and any local requirements. Contractor must drill hole on side or top of the control box to provide access.
6. The green power switch on the electric control box must remain in the OFF position until the TYCO Nitrogen Generator has been commissioned.
7. Inspection of the vent assembly should be performed after installation and hydrostatic testing of the fire sprinkler system. The inspection should be performed periodically thereafter in accordance with the applicable NFPA codes and standards, and/or the authority having jurisdiction.

NOTE: Inspection must include verifying the condition of the inline filter and checking for blockage in the “Y” strainer and the restricted venting orifice.

Operating Instructions

1. Verify the vent assembly has been equipped with a restricted venting orifice downstream of the backpressure regulator.

NOTE: If the vent assembly is not equipped with a restricted venting orifice, one will be provided by Johnson Controls during system commissioning. The restricted venting orifice must be installed before proceeding with the steps below.

2. Determine the low air alarm pressure and normal operating pressure of the fire sprinkler system
3. Choose a pressure setting for the backpressure regulator that is 3-5 psig (.2-.3 bar) above the low air alarm pressure but below the normal operating pressure of the fire sprinkler system.

NOTE: This process can only be performed when the solenoid on the vent is energized (power on and VENT button depressed), and fire sprinkler system is at normal operating pressure.

4. Pull the knob out from the regulator to adjust pressure setting. Turn the knob clockwise to raise the pressure, counter-clockwise to lower the pressure.
5. Close the isolation ball valve and allow device to depressurize through restricted venting orifice to pressure setting. Make adjustment to pressure setting using the knob, then open the isolation ball valve to pressurize device and close the isolation ball valve again to check pressure setting. Repeat process until desired pressure setting is achieved.

6. Push knob back into regulator until it clicks into place.
7. Verify the timer settings inside the electric control box. The settings should be as follows: mode set to 'E', scale set to '20, 30, 40, 50, 60', range set to '10h', and timer knob set to '35'. If needed, a small flathead screwdriver can be used to make the timer setting adjustments.
8. Once the TYCO Nitrogen Generator System has been commissioned, open the isolation ball valve on the vent assembly, turn the green power switch on the electric control box to the ON position and push the orange VENT button. The button should now be illuminated.
9. The TYCO SMART Dry Vent is now open and actively purging oxygen from the fire sprinkler system. It will remain open for approximately fourteen (14) days. The orange VENT button will turn off when the vent is closed.
10. If the sprinkler system actuates or another event introduces oxygen to the sprinkler system press the orange VENT button to restart the purging cycle.

TYCO Dry SMART Vent Control Box

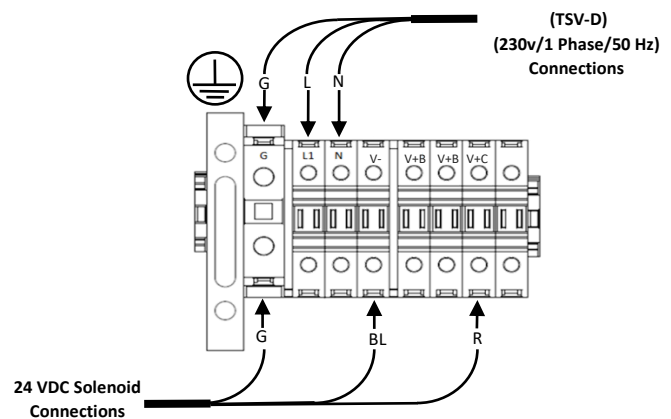
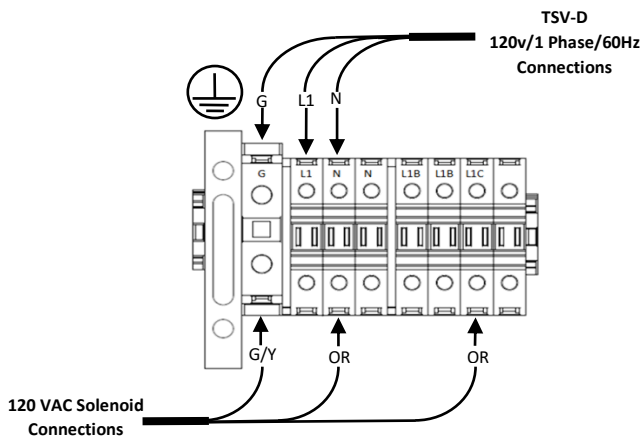
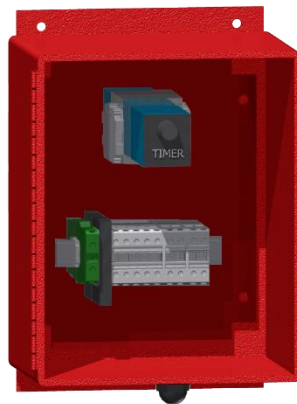

TYCO Dry SMART Vent Assembly

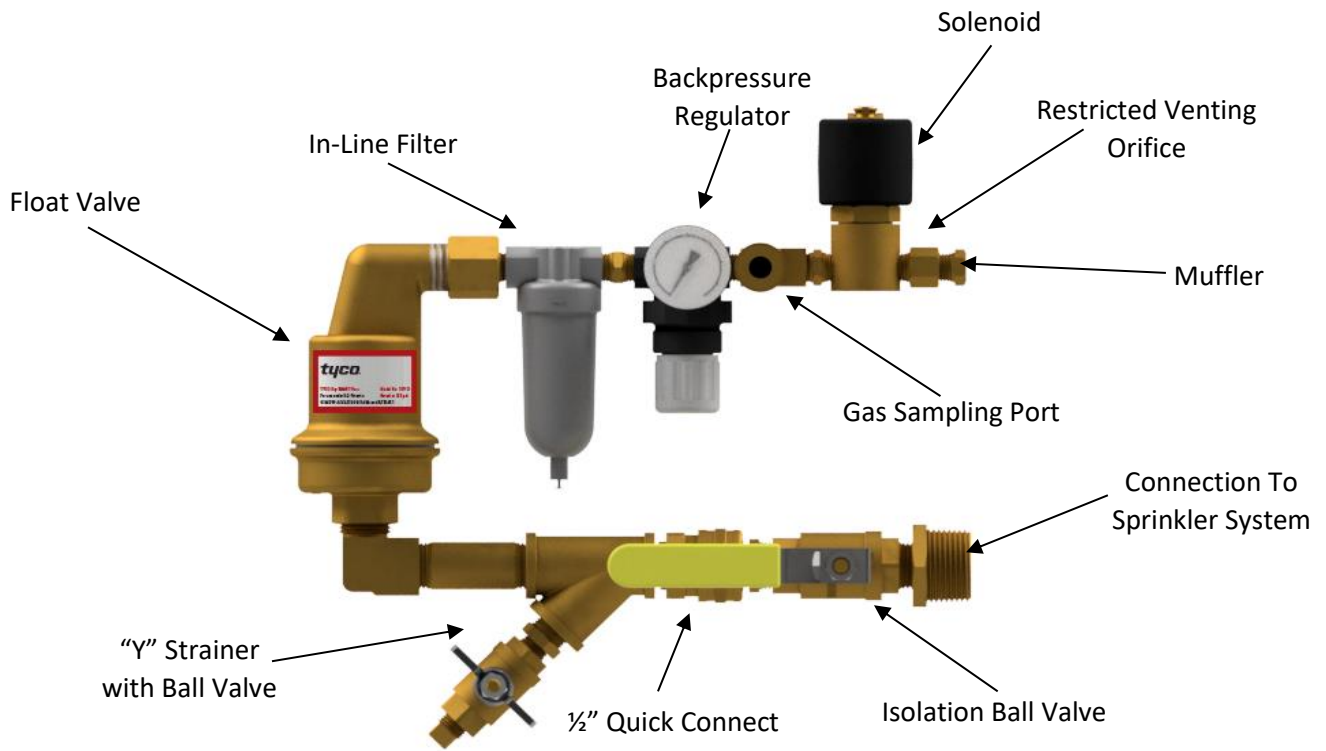

In-Line Filter Assembly

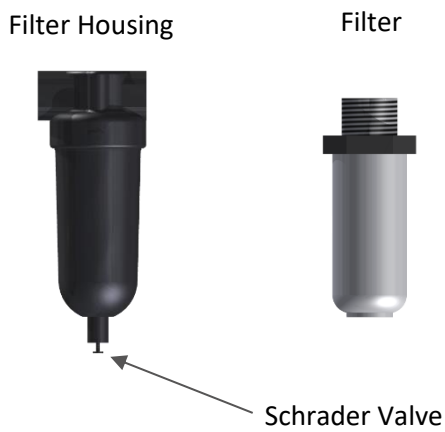

TYCO SMART Dry Vent Installation Schematic

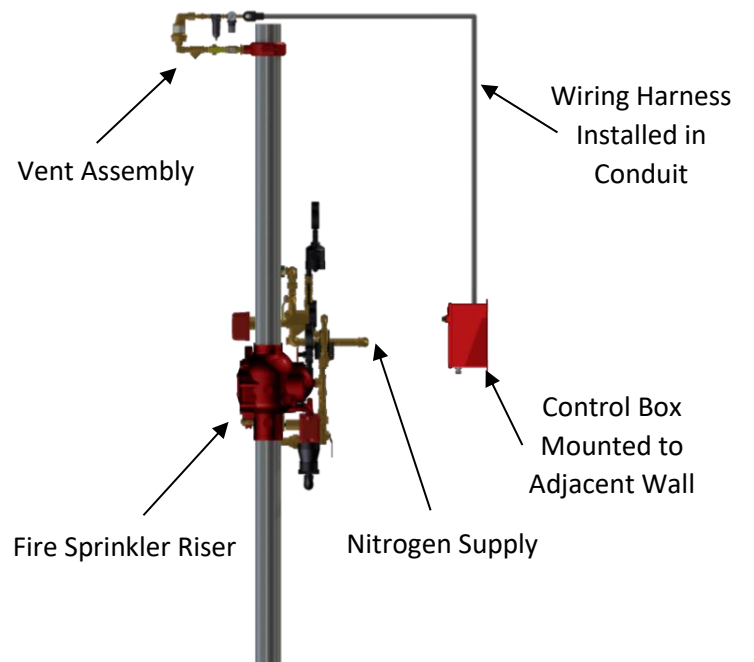

Monitoring – TILD & TSGA

TYCO In-Line Corrosion Detector (TILD)

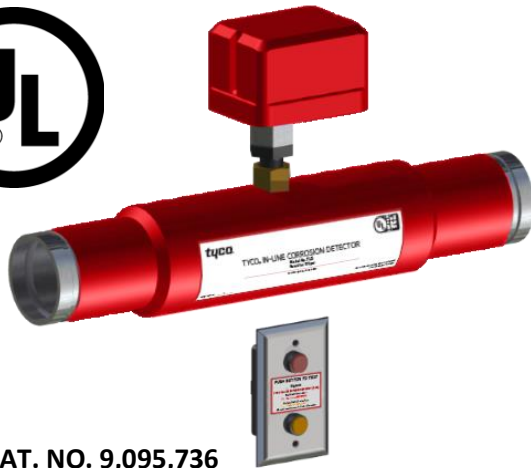

US. PAT. NO. 9,095,736

Specifications

Model Number:	TILD
Service Pressure:	175 psi
Temp. Rating:	-40°F to 120°F (-40°C to 49°C)
Elec. Connection:	dry contact
Pipe Size:	1.25" - 6"
Pipe Schedule:	Sch. 10 or Sch. 40
Pipe Material:	Black Steel or Galvanized

General Description

The TYCO In-Line Corrosion Detector (TILD) is designed to provide an early warning indication of internal corrosion activity in water-based fire protection systems. The device is designed to be installed where corrosion is most likely to occur: the air/water interface. A cross-section of the device shows the two key attributes that allow for early detection of corrosion: an externally milled section of the pipe that creates a “thin wall” section and a pressure chamber created by an external sleeve welded over the pipe. The thin wall section of the device will fail before other system piping to provide an early warning indication. The TYCO In-Line Corrosion Detector is equipped with a pressure switch to monitor the pressure chamber. The TYCO In-Line Corrosion Detector can be remotely monitored through a buildings monitoring system, or locally through the TYCO Remote Test Station (TRTI), which is included with the TILD.

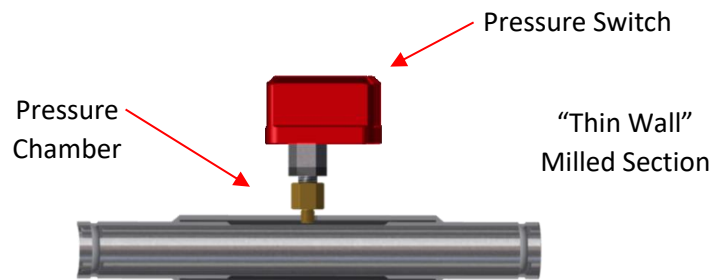

Installation Instructions

The TYCO In-Line Corrosion Detector is manufactured as a spool of piping with roll grooved ends for easy insertion into the fire sprinkler piping using grooved couplings. All models of the TYCO In-Line Corrosion Detectors are eighteen (18) inches in length. The variety of pipe schedules and metal are listed in the table under ordering information.

Step 1: Contact Johnson Controls to determine a location within the sprinkler system where corrosion is likely to occur. In wet pipe systems locate on a high point at the air/water interface and in dry pipe systems locate on the mains in an area with trapped water.

Step 2: At the chosen location in the fire sprinkler piping remove an eighteen (18) inch pipe section from the fire sprinkler system.

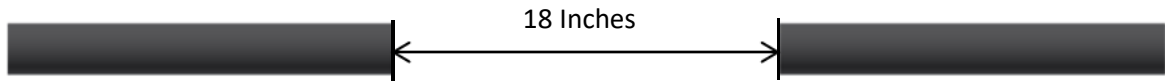

Step 3: Roll groove the remaining ends of the fire sprinkler system piping to receive a standard grooved coupling.

Step 4: Install the TYCO In-Line Corrosion Detector of matching pipe material, diameter and schedule into the section space that has been created with the removal of the eighteen (18) inch pipe section. Orient the TYCO In-Line Corrosion Detector so that the pressure switch is accessible for maintenance. Tighten the mechanical couplings as per the manufacturer’s specifications.

Step 5: OPTIONAL: Connect the wiring from the monitoring system to the pressure switch (dry contact) in accordance with the manufacturer’s wiring instructions. Activation of the TYCO In-Line Corrosion Detector should be identified as a supervisory signal.



TYCO Remote Test Station (TRTI) Installation Instructions

1. The TYCO Remote Test Station mounts to a 2" x 4" x 2 1/8" minimum depth handy box (Raco model 670RAC or approved equal) in an accessible location near the In-Line Corrosion Detector.
2. Recommended mounting height 72" AFF
3. Connect 2-conductor, in accordance with NFPA 70, between the In-Line Detector and the Remote Test Station (Recommended 18 AWG cable).
4. Provide any required raceway or mechanical protection, as required.
5. Connect the terminals of the Remote Station to the common (COM) and normally open (A) of the pressure switch.

Model EPS10-2 Pressure Switch Electrical Connections

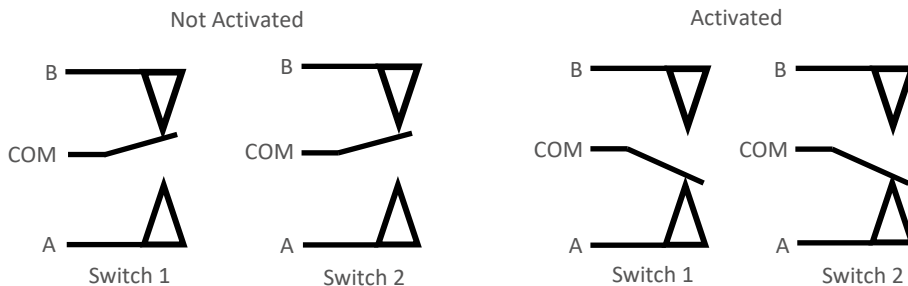

TYCO Remote Test Station (TRTI)

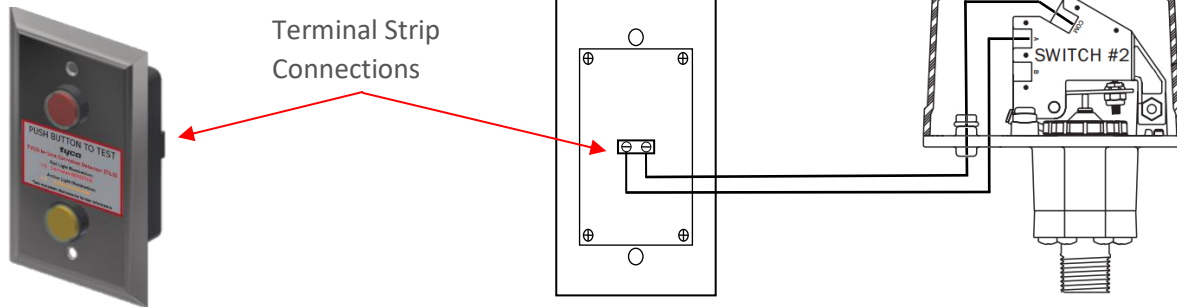

TYCO Remote Test Station Operation Flowchart

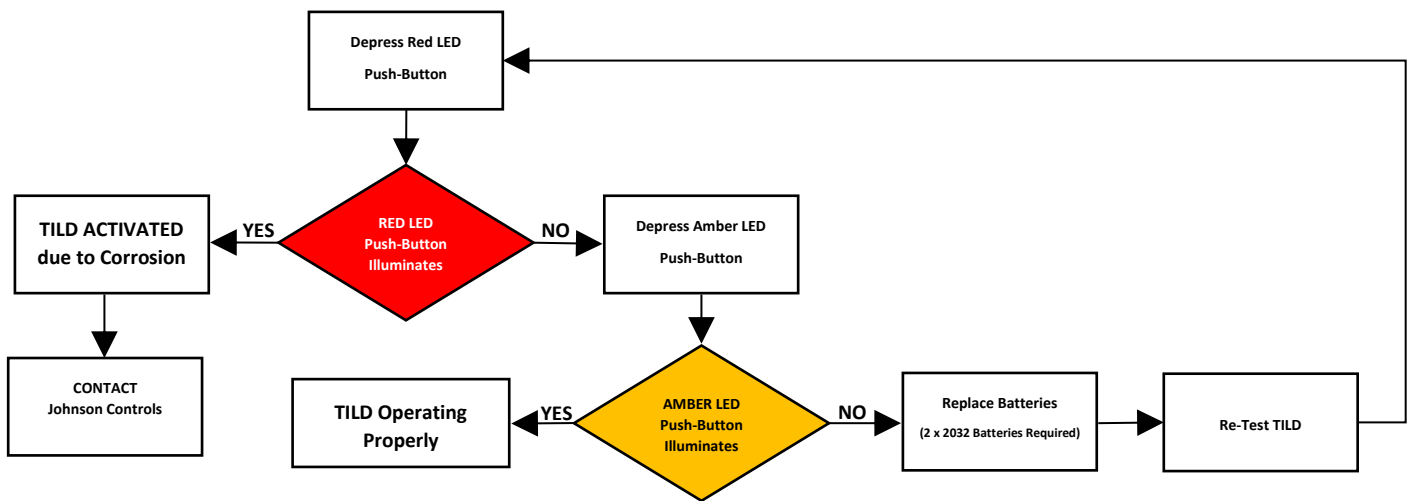

Response to Device Activation

Activation of the pressure switch indicates that the thin wall section of the device has failed and the pressure chamber is exposed to system pressure. Contact Johnson Controls for instructions regarding replacement and testing of the failed In-Line Corrosion Detector.

Battery Test and Replacement

1. Depress Amber LED Push Button. If Amber LED does not illuminate, battery replacement is required.
2. Remove Remote Test Station from electrical mounting box, remove four (4) back cover screws, remove two (2) 2032 batteries from battery holder.
3. Replace Battery with two (2) Energizer Part No. CR2032 Only*, re-install battery holder in backbox, reinstall back cover with four (4) screws and reinstall Remote Test Station in electrical mounting box.

* Use Of Another Battery May Present A risk Of Fire Or Explosion.

CAUTION: Battery May Explode if Mistreated. Do Not Recharge, Disassemble Or Dispose Of In Fire

These cells are intended for use at ordinary temperatures where anticipated high temperature excursions are not expected to exceed 100° C (212° F)

TYCO SMART Gas Analyzer (TSGA)



For use under U.S. Patent 9,144,700
and 9,186,533

Specifications

Model Number:	TSGA
Sensor Type:	Zirconium Dioxide
Electrical Connection:	120VAC, 60 Hz/0.5A 230VAC, 50 Hz/0.5A 24VDC/2A
Signal Output:	0-5VDC linear output 4-20mA linear output
Output Display:	%O ₂ or %N ₂
Resolution:	1dp (nn.n%)
Accuracy:	1%
Sample Connection:	5/32" nylon tubing quick connect
Dimensions:	8"(W) X 3.5"(D) X 8"(H) (203mm (W) X 89mm (D) X 203mm (H))

General Description

The TYCO SMART Gas Analyzer provides a continuous real-time monitoring of nitrogen/oxygen concentration levels within a dry/preaction fire protection system. The analyzer samples discharge gas from an adjacent TYCO Manual Vent (TAV-D) or SMART Vent (TSV-D). The gas flows out of a restricted orifice on the vent through pressure-rated tubing to provide slow, controlled flow to the analyzer. One TSGA analyzer is recommended with each TYCO Nitrogen Generation System.

The TSGA has many different functions. It is equipped with a programmable contact closure for one of three different oxygen concentration levels (1%, 3%, and 5%), which will provide early warning to a user when the nitrogen concentration within the fire protection system falls below the desired level. The TSGA is also equipped with an RS-485 port for optional remote control and monitoring. The TSGA can also display either oxygen or nitrogen concentration.

The TSGA is equipped to protect itself from damage, and also let the user know if the sensor is in poor health. Five minutes after the sensor is powered on, it begins a self-diagnostic protocol. If at this time the O₂ level is below 0.3%, the alarm relay will energize, and the sensor will automatically shut itself down. It will reboot automatically after 24 hours and resume reading gas concentration levels. Pumping at extremely low oxygen levels can eventually cause damage to the sensor. If the sensor detects rapid deviation in oxygen content it will signal an error and energize the alarm relay without shutting down.

Installation Notes

1. When connecting the TSGA Gas Analyzer to a fire protection system using the TAV-D Manual Vent, a dedicated TAV-D Manual Vent is required to provide a continuous gas stream to analyze. The muffler in the TAV-D must be removed and replaced with a 5/32" push-connect fitting.

- When connecting the TSGA Gas Analyzer to a fire protection system using the TSV-D SMART Vent, the quick disconnect sampling port in the TSV-D must be removed and replaced with a 5/32" push-connect fitting.

Installation Instructions

- Mount the TYCO SMART Gas Analyzer on a wall adjacent to the TAV-D Manual Vent or the TSV-D SMART Vent (not included).
- Once mounted, connect the 5/32" tubing to the push-connect fitting on the top of the TSGA.
- Connect the opposite end of the tubing to the push-connect fitting on the outlet of the TAV-D or TSV-D Vent.

TYCO SMART Gas Analyzer with TAV-D Dry Manual Vent Assembly

5/32" Push Fitting

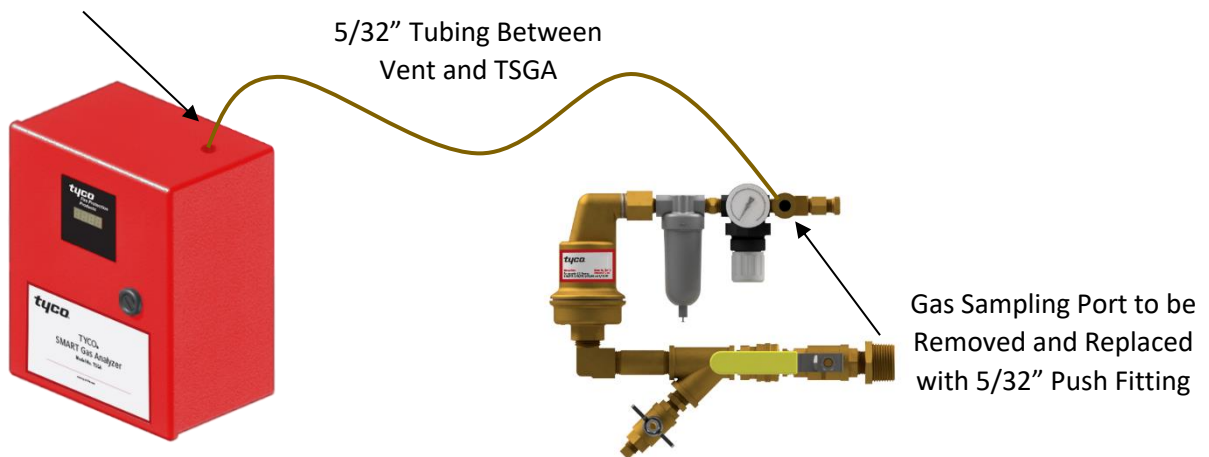

TYCO SMART Gas Analyzer with TSV-D Dry SMART Vent Assembly

5/32" Push Fitting

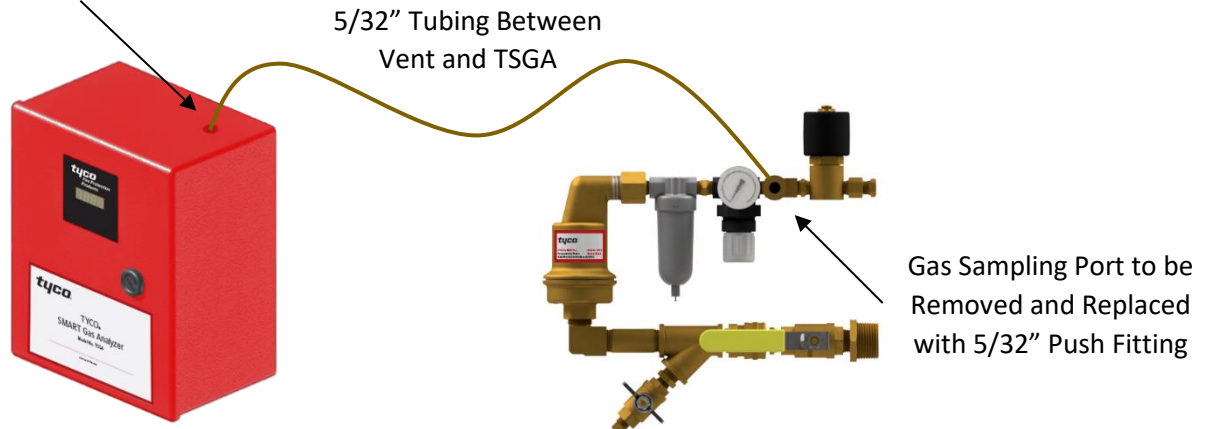

4. With the incoming power off, connect the incoming 120 VAC/60 Hz (230VAC/50 HZ) power supply to block "J6".
5. Select the appropriate gas concentration level to be displayed on the SGA-1/(SGA-1E) using Dip 1 of Switch 1. Nitrogen (N₂) or Oxygen (O₂).
Note: N₂ is recommended
6. When monitoring and a (N.O.) contact closure required, connect to the "Over" contacts on block J5 (J5-1 & J5-2).
 - a. If a LOW Nitrogen (N₂)/HIGH Oxygen (O₂) percentage alarm is desired, select the corresponding O₂ concentration level using dip 2, 3 or 4 of Switch 1 to energize the "OVER" relay output.
 - b. Dip 2 of Switch 1 (5%) is recommended.
7. When monitoring and an analog output is required, connect positive lead to AOUT+ (J4-1) and negative lead to AOUT- (J4-2).
 - a. Turn on Dip 1 of Switch 2 to select 4-20mA output.
 - b. Use Dip 2 of Switch 2 to select 5V (for 0-5V) or 10V (for 0-10V).
8. If RS-485 remote control/monitoring is desired, connect RS-485 leads to D+ (J4-4), D- (J4-5) and DGND (J4-6).

Alarm Bypass While Nitrogen Inerting Feature

The "Over" contacts can be bypassed from transmitting a low nitrogen signal to the building monitoring system during the 14-day nitrogen inerting process when the TSGA is used in conjunction with the TSV-D SMART Vent.

1. Connect the spare normally closed (NC) contacts (terminals 8 and 11) in the TSV-D SMART Vent Controller with the normally open (NO) contacts of the TSGA-Terminals J5-1 and J5-2.
2. Connect the output of the TSGA and TSV-D to the building monitoring system.
3. Connect the building monitoring system's end-of-line supervision device (if needed)

Operating Instructions

1. Once unit is verified to be wired correctly, power unit on. The status LED light will repeatedly flash green two times quickly for two (2) minutes. The sensor heater is warming up during this period.
2. After the two-minute warm-up period, the sensor and status LED light will flash green one time repeatedly indicating normal operation. At this time, the display will show the current average concentration of the feed gas.

PC Board Wiring Diagram

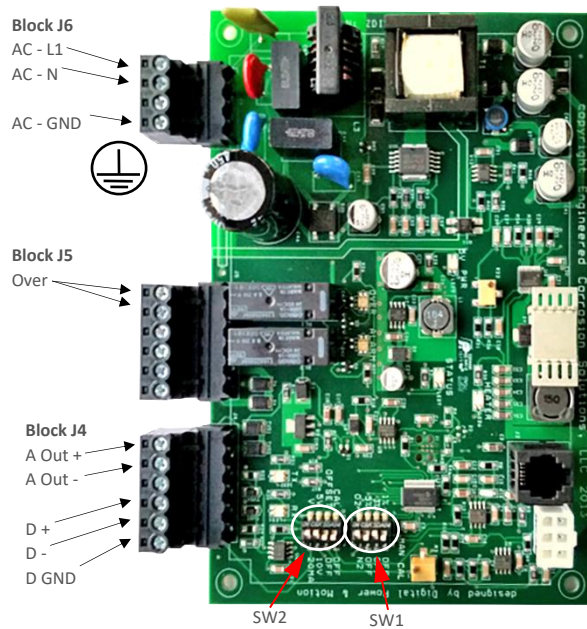

Inerting Bypass Wiring Diagram

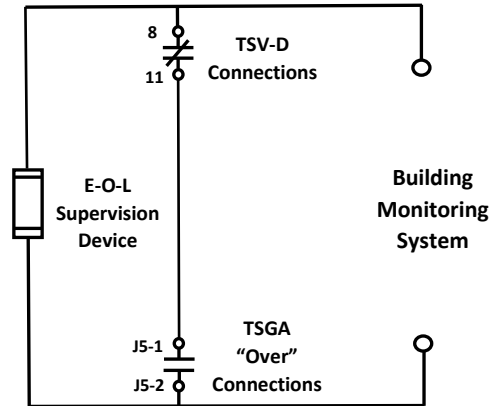

Calibration

The TYCO Model TSGA SMART Gas Analyzer is factory calibrated to read a 20.9% oxygen level. As elevation increases, the density of the Oxygen molecules in the air decreases. Decreased Oxygen molecules in the air can cause the SMART Gas Analyzer to display slight inaccuracies in the displayed Oxygen/Nitrogen percentage concentration value.

Note: Please contact Johnson Controls before any calibration adjustment

To recalibrate the SMART Gas Analyzer:

1. Verify the SMART Gas Analyzer is connected to a sprinkler system that is pressurized with fresh compressed air.
2. Verify the SMART Gas Analyzer is sampling fresh compressed air for a minimum of 10 minutes.
3. Switch the N2/O2 switch (SW1 DIP1) to the O2 position, if the digital display is not reading approximately 20.9%, switch the "CAL" switch (SW2 DIP4) to the "CAL" position.
4. Allow the SMART Gas Analyzer to remain in the "Calibrate Mode" and sample the gas for 10 minutes to allow the TSGA to re-calibrate.
5. Switch the "CAL" switch (SW2 DIP4) to the "Off" position.
6. Verify the digital display is reading approximately 20.9%.
7. Switch the N2/O2 switch (SW1 DIP1) to the N2 position.

PC Board – LED Locations

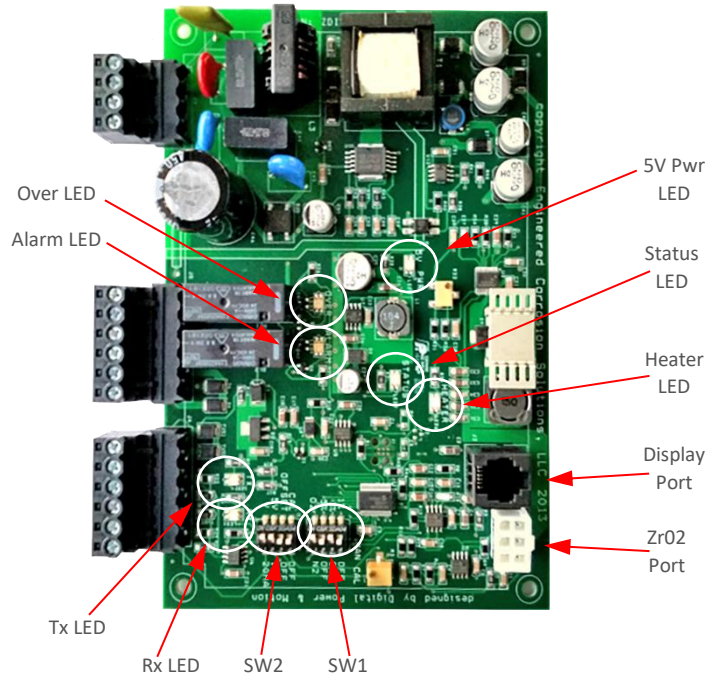

LED Identification Chart

STATUS LED Color	Flash Code	Condition
Red	1	ERROR: Low O ₂ Level (<.3%)
Red	2	ERROR: Assymetry >5%
Green	1	Normal Operation
Green	2	Heater Warming Up
Green	3	Averaging Calibration Value
Green	4	Set Calibration Value w/ Cal Pot if Desired

Commissioning

SAFETY WARNING

Commissioning of nitrogen generator is to be performed by qualified personnel. Prior to any system commissioning on the nitrogen generator, ensure that the nitrogen generator is isolated from all system risers. Failure to do so can result in system damage and/or personal injury.

Nitrogen Generator Pressure Settings

Prior to setting the cut-in and cut-out pressures of the nitrogen generator, identify the following sprinkler system pressures:

1. Sprinkler system operating pressure/Air Maintenance Device (AMD) pressure.

NOTE: When the nitrogen generator is connected to multiple dry pipe/preaction systems, the AMD pressures must be the same for all the sprinkler systems.

2. Sprinkler system low air alarm pressure.
3. Sprinkler system trip pressure.

Once the sprinkler system pressures have been identified, determine the cut-in and cut-out pressures of the nitrogen generator.

1. The nitrogen generator cut-in pressure is to be 3-5 psig (.2-.3 bar) below the operating/AMD pressure of the sprinkler system(s).
2. The nitrogen generator cut-in pressure needs to be 3-5 psig (.2-.3 bar) above the low air alarm pressure of the sprinkler system(s).
3. The nitrogen generator cut-out pressure is preset from the factory at 60 psig (4.1 bar) which should be adequate for most applications. Should a higher cut-out pressure be needed, adjust the cut-out pressure using the cut-out pressure adjustment procedure.

Sprinkler System Air Maintenance Device (AMD) Pressure

The proper operation of the nitrogen generator and the dry pipe nitrogen inerting (DPNI) process is dependent on the sprinkler system's air maintenance device (AMD) pressure setting. Sprinkler system AMD pressure settings less than 3 psig (.2 bar) above the nitrogen generator cut-in pressure or greater than 5 psig (.3 bar) above the nitrogen generator cut-in pressure will have an adverse effect on the service life of the nitrogen generator.

Verify the AMD pressure setting using the Air Maintenance Device (AMD) Pressure Adjustment Procedure in the Maintenance Section of this manual.

Nitrogen Generator Pressure Adjustments

The nitrogen generator cut-in and cut-out pressure settings are established and set as part of the commissioning process of the nitrogen generator and do not need to be readjusted unless the fire sprinkler system parameters change. Any adjustments to the nitrogen generator cut-in and cut-out pressure settings will affect the TYCO Manual Vent (TAV-D) or SMART Vent (TSV-D) backpressure regulator settings, which will require readjusting the backpressure regulators to coincide with the changes to the nitrogen generator cut-in and cut-out pressure settings.

NOTE: Any changes to the nitrogen generator cut-in and cut-out pressure settings or the vent backpressure regulator settings must be authorized by and under the direction of Johnson Controls.

1. Locate the Pressure Transducer in the nitrogen generator. (See Maintenance Section for Generator Configuration Diagram).
2. Adjust the nitrogen generator cut-in pressure. (See Maintenance Section for Nitrogen Generator Pressure Adjustment Procedure).
3. Adjust the nitrogen generator cut-out pressure, if needed. (See Maintenance Section for Nitrogen Generator Pressure Adjustment Procedure).

Nitrogen Generator Start Up and System Check Instructions

Once the cut-in and cut-out pressures have been determined and programmed into the Pressure Transducer, the nitrogen generator can be started to verify nitrogen production and nitrogen purity.

1. Verify the nitrogen generator is in the “nitrogen generation mode”.
2. Verify the “fast fill” valves of all appropriate air maintenance devices (AMDs) are closed.
3. Close the regulated valve of all appropriate air maintenance devices (AMDs).
4. Turn on the nitrogen generator (if nitrogen generator is not already on).
5. Partially open the nitrogen production flow meter isolation ball valve to automatically start the nitrogen generator to generate nitrogen.

NOTE: The nitrogen generator incorporates an eight (8) second delay upon nitrogen generator start for protection of the integral air compressor.

NOTE: Adjust the position of the flow meter isolation ball valve so that the pressure indicated on the Pressure Transducer remains constant between the nitrogen generator’s cut-in and cut-out pressures.

6. Allow the nitrogen generator to operate in the nitrogen production mode for approximately five (5) minutes to allow the nitrogen generator to obtain optimum operating temperature.

NOTE: Operating nitrogen generator with the door closed during initial start-up reduces time required for nitrogen generator to obtain optimum operating temperature.

7. Connect the Handheld Gas Analyzer to the quick connect gas sampling port in the nitrogen generator to verify the nitrogen purity is 98%.

NOTE: Prior to connecting the Handheld Gas Analyzer to the nitrogen generator, calibrate the Handheld Gas Analyzer using the calibration procedures. (See Maintenance Section for Nitrogen Purity Check Procedure).

8. The nitrogen purity was verified to be producing 98% nitrogen purity prior to equipment shipment from Johnson Controls. Should the purity not be 98%, contact Johnson Controls prior to making changes to the nitrogen purity.
 - a. If the nitrogen purity is above 98%, decrease the nitrogen purity by turning the Nitrogen Flow Control Valve counterclockwise in $\frac{1}{8}$ turn increments (See Generator Configuration Diagram).
 - b. If the nitrogen purity is below 98%, increase the nitrogen purity by turning the Nitrogen Flow Control Valve clockwise in $\frac{1}{8}$ turn increments (See Generator Configuration Diagram).

IMPORTANT NOTE: Nitrogen purity and nitrogen production rate are inversely proportional in the nitrogen generator. **As the nitrogen purity increases (above 98%) the nitrogen production rate decreases (lower SCFH) and as the nitrogen purity decreases (below 98%) the nitrogen production rate increases (higher SCFH).** Lower nitrogen production rates will increase system fill times resulting longer run times of the nitrogen generator.

9. Verify and document the nitrogen production rate as indicated on the flow meter in the nitrogen generator (See Maintenance Section for Nitrogen Production Flow Rate Procedure).
10. Close the nitrogen production flow meter isolation ball valve, allow the pressure to increase to the nitrogen generator's cut-out pressure and the nitrogen generator to shut off.
11. Once nitrogen generator has shutoff, monitor the pressure transducer digital display to ensure the pressure indicated remains constant and does not decrease.
 - a. If pressure decreases, a leak within the nitrogen cabinet or in the nitrogen supply line exists, leak check all piping and fittings within the nitrogen generator and repair leaks as necessary.
12. Open the regulated valve of all appropriate air maintenance devices (AMDs) and confirm the "fast fill" valves of all appropriate air maintenance devices (AMDs) are closed.
13. The nitrogen generator is ready to protect the fire sprinkler system(s).

Nitrogen Generator Leak Monitor Alarm

The nitrogen generator and air compressor are designed to run for up to four (4) hours at a time when filling all the systems with 3-5 psig (.2-.3 bar) of high purity nitrogen. If air compressor and nitrogen generator runtimes are greater than four (4) hours, the nitrogen generator activates an audible alarm and the leak monitor output contacts.

Verify the Leak Monitor Alarm is configured using the Nitrogen Generator Leak Monitor Adjustment Procedure in the Maintenance Section of this manual.

Oxygen Removal Vent Setup and Pressure Regulator Adjustment Instructions

Once the nitrogen generator has been commissioned, the oxygen removal vents can be commissioned.

1. Install the appropriate restricted venting orifice in the oxygen removal vent by removing the vent muffler downstream of the backpressure regulator, installing the restricted venting orifice and re-installing the vent muffler.
 - a. The restricted venting orifice size is determined by the sprinkler system capacity (gallons).
 - b. Consult with Johnson Controls to ensure the appropriate restricted venting orifice is installed in the appropriate oxygen removal vent.
2. Base on the nitrogen generator cut-in pressure and the sprinkler system low alarm pressure, adjust the pressure setting for the backpressure regulator.
 - a. Choose a pressure setting for the backpressure regulator that is 3-5 psig (.2-.3 bar) above the low air alarm pressure and below the cut-in pressure of the nitrogen generator.
 - b. Manual Oxygen Removal Vents:
 - i. Pull the knob out from the regulator to adjust pressure setting. Turn the knob clockwise to raise the pressure, counter-clockwise to lower the pressure.
 - ii. Close the isolation ball valve and allow device to depressurize through the restricted venting orifice to pressure setting. Make adjustment to pressure setting using the knob, then open the isolation ball valve to pressurize device and close the isolation ball valve again to check pressure setting. Repeat process until desired pressure setting is achieved.

NOTE: This process can only be performed when fire sprinkler system is at normal operating pressure.

- iii. Push knob back into regulator until it clicks into place.
- iv. Once the TYCO Nitrogen Generator System has been commissioned, open the isolation ball valve on the vent assembly. The TYCO Manual Vent is now open and actively venting oxygen from the fire sprinkler system.
- v. The isolation ball valve should remain open for approximately fourteen (14) days or until the system nitrogen concentration reaches 98% or greater.

NOTE: Use an TYCO Handheld Gas Analyzer to verify the gas concentration inside the fire sprinkler system.

- vi. At the conclusion of the oxygen venting cycle, Close the isolation ball valve.

NOTE: Failure to close the manual ball valve after 14 days or once fire sprinkler system nitrogen concentration reaches 98% will result in additional oxygen corrosion damage to the system and unnecessary run time of the air compressor and nitrogen generator.

- vii. If the sprinkler system actuates or another event introduces oxygen to the sprinkler system the manual ball valve must be opened again for a period of fourteen (14) days to vent oxygen from the system.

c. SMART Oxygen Removal Vents:

- i. Verify the timer settings inside the electric control box. The settings should be as follows: mode set to 'E', scale set to '20, 30, 40, 50, 60', range set to '10h', and timer knob set to '35'. If needed, a small flathead screwdriver can be used to adjust the timer settings.

NOTE: The green power switch on the electric control box must be in the ON position and the orange VENT button depressed with both the green power switch and the orange VENT button illuminated to adjust the vent pressure regulator.

- ii. Pull the knob out from the regulator to adjust pressure setting. Turn the knob clockwise to raise the pressure, counter-clockwise to lower the pressure.
- iii. Close the isolation ball valve and allow device to depressurize through restricted venting orifice to pressure setting. Make adjustment to pressure setting using the knob, then open the isolation ball valve to pressurize device and close the isolation ball valve again to check pressure setting. Repeat process until desired pressure setting is achieved.

NOTE: This process can only be performed when fire sprinkler system is at normal operating pressure.

- iv. Push knob back into regulator until it clicks into place.
- v. Once the TYCO Nitrogen Generator System has been commissioned, open the isolation ball valve on the vent assembly, turn the green power switch on the electric control box to the ON position and push the orange VENT button. The button should now be illuminated.
- vi. The TYCO Dry SMART Vent is now open and actively venting oxygen from the fire sprinkler system. It will remain open for approximately 14 days.
- vii. At the conclusion of the oxygen venting cycle, the orange VENT button will extinguish and the vent will automatically close.
- viii. If the sprinkler system actuates or another event introduces oxygen to the sprinkler system press the orange VENT button to automatically restart the oxygen venting cycle.

Maintenance

SAFETY WARNING

All maintenance is to be performed by qualified personnel. Prior to any system maintenance on the nitrogen generation system, ensure that the nitrogen generator is isolated from the compressed air supply and all system risers. Ensure that the nitrogen generation system and the associated piping that is to be manipulated is completely depressurized prior to performing any maintenance. Failure to do so can result in system damage and/or personal injury.

MAINTENANCE and TROUBLESHOOTING WARNINGS

1. Nitrogen Generator includes 120 VAC 60 Hz (230 VAC 50 Hz) voltage inside cabinet – exercise caution and do not touch any wiring connections when power is applied to the unit.
2. Nitrogen Generator has hot surfaces inside cabinet when nitrogen generator is operating and after nitrogen generator has turned off – exercise caution when working on nitrogen generator while operating and after nitrogen generator has shut off. (***Wear Hand Protection, where needed***)

Routine Checks

The nitrogen generators require limited maintenance; however, it is advisable to routinely check the generator to ensure functionality. The following is a checklist and schedule for routine inspection.

Check	Occurrence
Verify all valves have smooth operation - clean and un-corroded	Quarterly
Verify all manual valves fully open and close	Quarterly
Verify compressor is turning on/off at low/high pressure	Quarterly
Verify correct nitrogen purity level out of cabinet sampling port	Quarterly
Verify pressure gauges are in working order	Quarterly
Verify there are no noticeable leaks on unit	Quarterly
Check coalescing filters	Semi-annually
Check for loose connections in cabinet and control box	Semi-annually
Check compressor filter	Semi-annually
Replace coalescing filters	Annually
Verify Oxygen Removal Vent In-Line Filter and Y-Strainer are clean	Annually
Verify no air or water leaks in Oxygen Removal Vent	Annually

Nitrogen Purity Level Check Procedure

Nitrogen purity level in the fire sprinkler system can be checked by inserting the TYCO Handheld Gas Analyzer (THGA) into the nitrogen sampling port in the nitrogen generator cabinet or the gas sampling port on the TAV-D or TSV-D Vent.

1. Power On the THGA by depressing the power on button.
2. Calibrate the THGA by depressing and holding the calibration button for three (3) seconds until "CAL" is displayed.

NOTE: To calibrate analyzer, unscrew sampling hose from analyzer and move back and forth until reading is displayed.

- a. THGA must be recalibrated if nitrogen percentage displayed is above 80.1% or below 78.1% when reading normal atmosphere, not connected to the nitrogen generator cabinet or vent.
 - b. Recommended to recalibrate analyzer daily when in use.
3. Once the THGA is calibrated, insert the quick disconnect of the sampling hose into the sampling port in the nitrogen generator cabinet/vent.

NOTE: Nitrogen generator must be operating in “nitrogen production mode” to sample nitrogen in cabinet.

Vent must be open to sprinkler system pressure to sample nitrogen in sprinkler system.

4. Allow one (1) minute for the THGA to stabilize, verify and document reading on THGA (nitrogen level should be approximately 98%). If nitrogen level from generator is below 96%, contact Johnson Controls.

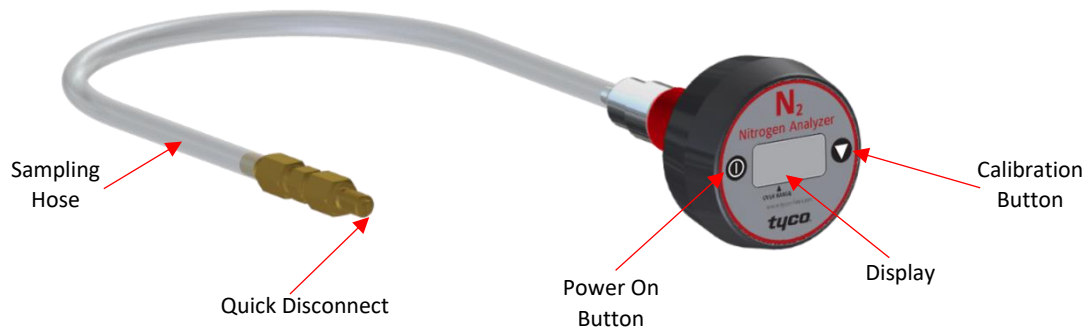

Handheld Gas Analyzer - Factors Influencing Accurate Readings

1. Elevation changes will affect the accuracy of the nitrogen purity readings. The deviation of the nitrogen purity can be approximately 1% per 250 feet of elevation.
 - a. Calibration of the instrument should be performed when elevation at which the product used changes more than 500 feet.
2. Temperature effects the accuracy of the nitrogen purity readings. The gas analyzer will hold calibration and correctly read nitrogen purity $\pm 3\%$ when thermal equilibrium within the operating temperature range. The device must be thermally stable when calibrated and allowed to thermally stabilize after experiencing temperature changes before readings are accurate.
 - a. For best results, perform the calibration procedure at a temperature close to the temperature where analysis will occur.
 - b. Allow adequate time for the sensor to equilibrate to a new ambient temperature.

CAUTION: “CAL Err St” may result from a sensor that has not reached thermal equilibrium.

Nitrogen Generator Leak Monitor Adjustment Procedure

The nitrogen generator leak monitor configuration can be verified by checking the settings of the leak monitor alarm module in the nitrogen generator cabinet (See Generator Configuration Diagram).

1. Locate the Leak Monitor (Finder) Module in the nitrogen generator
2. Verify the module scale setting (white control) is set to '24h'
3. Verify the module timer setting (blue control) is set to '4'
4. If needed, a small flathead screwdriver can be used to adjust the controls.

NOTE: If adjustment needed, turn controls fully clockwise and then counter-clockwise before setting at the identified positions.

Nitrogen Production Flow Rate Check Procedure

The production rate of the nitrogen generator can be verified using the production flow meter in the nitrogen generator cabinet (See Generator Configuration Diagram).

1. With the nitrogen generator powered and in the nitrogen production mode:
 - a. Partially open the nitrogen production flow meter isolation ball valve to automatically start the nitrogen generator.

NOTE: Adjust the position of the flow meter isolation ball valve so that the pressure indicated on the Pressure Transducer remains constant between the nitrogen generator's cut-in and cut-out pressures.

- b. Close the regulated and fast fill valves on the air maintenance device (AMD) to the fire sprinkler system(s).
 - c. Read and document the nitrogen production flow rate on the nitrogen production flow meter.
 - i. Flow rate indicated is in standard cubic feet per hour (SCFH).
 - ii. The production rate is measured using the center of the silver ball in the flow meter.
 - d. Open the regulated valve on the air maintenance device (AMD) to the fire sprinkler system(s).
 - e. Close the flow meter isolation ball valve.
 - f. Compare the nitrogen production flow rate with the nitrogen production values listed in the following chart.

Nitrogen Generator Flow Rates

Nitrogen Generator	Production Rate – SCFH (L/min)			
	Bypass Mode	Nitrogen Generation Mode		
		70 psig (4.8 bar)	100 psig (6.9 bar)	150 psig (10.3 bar)
NG-1 100 Wall Mount w/ Integral Air Compressor	150 (70.8)	20 (9.4)	N/A	N/A
NG-1 250 Wall Mount w/ Integral Air Compressor	198 (93.5)	N/A	27 (12.7)	N/A
NG-1 500 Wall Mount w/ Integral Air Compressor	342 (161.4)	N/A	N/A	44 (20.8)
NG-1 1000 Skid Mount w/ Integral Air Compressor	600 (283.2)	N/A	76 (35.9)	N/A
NG-1 1150 Stand Alone w/ 5 hp Air Compressor	858 (404.9)	N/A	130 (61.4)	240 (113.3)
NG-1 1500 Stand Alone w/ 7.5 hp Air Compressor	1,458 (688.1)	N/A	130 (61.4)	240 (113.3)
NG-1 2000 Stand Alone w/ 7.5 hp Air Compressor	1,458 (688.1)	N/A	225 (106.2)	425 (200.6)
NG-1 3000 Stand Alone w/ 10 hp Air Compressor	2,100 (991.1)	N/A	285 (134.5)	550 (259.6)

NOTE: If production flow rate is lower than flow rates in the production chart, check pressure regulator of the excess bleed off assembly.

If production flow rate identified and documented varies more than 10% of the flow rates in the production chart, contact Johnson Controls.

Air Maintenance Device (AMD) Pressure Adjustment Procedure

The sprinkler system air maintenance device (AMD) operating pressures are determined by the sprinkler system valve, system water pressure and water delivery time requirements as defined by NFPA 13. The AMD operating pressures should not need to be readjusted unless one of the above fire sprinkler system parameters change.

The following procedure has been developed to account for:

1. Tolerances of the gauges used on fire sprinkler systems
2. Inlet pressure fluctuations to the AMD resulting in pressure fluctuations of the AMD.

NOTES:

- System operating pressures for all sprinkler systems served by a nitrogen generator must be the same.
- Any changes to the AMD pressure settings must be correlated with the nitrogen generator cut-in (turn-on) and cut-out (turn-off) pressure settings; and be authorized by and under the direction of Johnson Controls.
- Accuracy of pressure gauges typically used in the fire protection industry can vary as much as 8-12 psi (.6-.8 bar) (See Operational Information - Sprinkler System Gauge Accuracy).

Step 1: Determine the operating pressure for all AMD's connected to a single nitrogen generator. The operating pressure must be the same for all AMD's.

NOTE: AMD's operating at different operating pressures will have an adverse effect on the operation and can reduce the service life of the nitrogen generator.

- Step 2:** Close the valves to all accelerators on the sprinkler systems (if installed).
- Step 3:** Temporarily set the cut-in (turn-on) pressure of the nitrogen generator to be 15 psig (1 bar) below the cut-out (turn-off) pressure of the nitrogen generator using the Nitrogen Generator Pressure Adjustment Procedure in the Maintenance Section of this manual.
- Step 4:** Relieve gas from nitrogen/air supply line to sprinkler system AMDs to allow nitrogen generator to cycle on and off.
- Step 5:** Close the all AMD valves on any system not being checked.
- Step 6:** Verify the fast fill (bypass) valve is closed and the inlet/outlet valves are open on the AMD for the system being checked.
- Step 7:** Adjust the AMD for the system being checked to the predetermined set pressure.
- Step 8:** Repeat Steps 5, 6 and 7 for each additional AMD connected to the nitrogen generator.
- Step 9:** Set the cut-in (turn-on) pressure of the nitrogen generator to the predetermined pressure 3-5 psig (.2-.3 bar) below the AMD set pressure using the Nitrogen Generator Pressure Adjustment Procedure in the Maintenance Section of this manual.
- Step 10:** Close the all AMD valves on any system not being checked.
- Step 11:** Verify the fast fill (bypass) valve is closed and the regulated valve is open on the AMD for the system being checked
- Step 12:** Relieve gas from the system until the nitrogen generator turns on. Allow the system to fill while monitoring digital display of the pressure transducer in nitrogen generator.

NOTE: Pressure increase in sprinkler system and on the pressure transducer digital display with AMD open, the pressure increase will be gradual. When the system operating pressure reaches the AMD pressure setting and the AMD closes, the pressure on the sprinkler system air gauge will stop rising and the pressure on the pressure transducer digital display will increase at a rapid pace until the nitrogen generator turns off (cut-out pressure).

- Step 13:** Compare the pressure indicated on the pressure transducer digital display at the transition of gradual to rapid increase to the pressure indicated on the AMD and/or system pressure gauges.

NOTE: The pressure indicated on the pressure transducer digital display at the transition of gradual to rapid increase will be the pressure at which the AMD pressure regulation device is currently set.

- If the pressure indicated on the pressure transducer digital display at the transition of gradual to rapid increase is the sprinkler system target pressure, proceed to **Step 15**.
- If the pressure indicated on the AMD/system pressure gauge at the transition of gradual to rapid increase is **LESS THAN** the sprinkler system target pressure, proceed to **Step 14a**.
- If the pressure indicated on the AMD/system pressure gauge at the transition of gradual to rapid increase is **MORE THAN** the sprinkler system target pressure, proceed to **Step 14b**.

- Step 14a:** If the pressure at which the AMD pressure regulating device is set is **LESS THAN** the target operating pressure, increase the pressure setting of the AMD by ¼ of a turn increment (cw) (increment can be different at discretion of operator) and return to **Step 12**.
- Step 14b:** If the pressure at which the AMD pressure regulating device is set is **MORE THAN** the target operating pressure, decrease the pressure setting of the AMD by ¼ of a turn increment (ccw) (increment can be different at discretion of operator) and return to **Step 12**.
- Step 15:** Return to **Step 12** and repeat the process to verify that the operating pressure readings are consistent. If the pressure reading is as expected mark the location of the indicator on the air pressure gauge of the system being tested (and on the AMD pressure gauge if applicable).
- Step 16a:** If there is another system being supplied by the nitrogen generator that has not had the pressure setting procedure performed then proceed to that system and return to **Step 10**.
- Step 16b:** If there are no other systems being supplied by the nitrogen generator that need the pressure setting procedure performed, proceed to **Step 17**.
- Step 17:** Determine the nitrogen generator cut-in (turn-on) pressure by subtracting 5 psig (.3 bar) from the target system operating pressure determined at the beginning of this procedure.

NOTE: If subtracting 5 psig (.3 bar) from the target operating pressure results in a pressure that is within 3 psig (.2 bar) of the low air alarm then subtract 3 psig (.2 bar) from the target operating pressure instead of 5 psig (.3 bar). If subtracting 3 psig (.2 bar) from the target operating pressure results in a pressure that is within 3 psig (.2 bar) of the low air alarm then contact Johnson Controls for direction.

- Step 18:** Program the cut-in (turn-on) pressure into the digital pressure transducer in the nitrogen generator (See Maintenance Section - Nitrogen Generator Pressure Adjustment Procedure).
- Step 19:** Slowly depressurize the sprinkler system(s) individually to the cut-in (turn-on) pressure where the generator turns on and verify:
- The pressure setting on the AMD/system pressure gauge at which the nitrogen generator turns on.
 - That a low air alarm is not received on any fire sprinkler system being supplied by the nitrogen generator prior to the nitrogen generator turning on.
 - The nitrogen generator fills the sprinkler system(s) to the appropriate operating pressure and then turns off.
- Step 20:** Confirm all AMD fast fill (bypass) valve(s) are closed and the regulated valve(s) are open on all the system AMD(s).
- Step 21:** Open all valves to the accelerators on the sprinkler systems (if installed).









END OF PROCEDURE

Nitrogen Generator Pressure Adjustment Procedure









The nitrogen generator cut-in (turn-on) and cut-out (turn-off) pressure settings are established and set during the commissioning process of the nitrogen generator and do not need to be readjusted unless the fire sprinkler system parameters change. Any adjustments to the nitrogen generator cut-in and cut-out pressure settings will affect the TYCO Manual Vent (TAV-D) or SMART Vent (TSV-D) backpressure regulator settings, which will require readjusting the backpressure regulators to coincide with the changes to the nitrogen generator cut-in and cut-out pressure settings. (Pressure Transducer Location, See Generator Configuration Diagram)

NOTE: Any changes to the nitrogen generator cut-in and cut-out pressure settings or the vent backpressure regulator settings are to be authorized by and under the direction of Johnson Controls.

Cut-In Pressure Adjustment

1. Locate the Pressure Transducer inside the nitrogen generator cabinet.
2. Depress the "DOWN"  key for a minimum of two (2) seconds to enter Programming Mode (Digital Display Flashing).
3. Scroll through the MAIN Programming Menu Functions on the LCD display using the "UP"  or "DOWN"  key until the "RP1" function is displayed on the LCD screen.
4. Depress the "ENTER"  key.
5. Using the "UP"  or "DOWN"  buttons, adjust the cut-in pressure until the desired pressure is displayed on the LCD screen.
6. Depress the "ENTER"  key.
7. Depress both the "UP"  or "DOWN"  keys simultaneously to exit the Programming Mode and return to the Display Mode.

Cut-Out Pressure Adjustment

1. Locate the Pressure Transducer inside the nitrogen generator cabinet.
2. Depress the "DOWN"  key for a minimum of two (2) seconds to enter Programming Mode (Digital Display Flashing).
3. Scroll through the MAIN Programming Menu Functions on the LCD display using the "UP"  or "DOWN"  key until the "SP1" function is displayed on the LCD screen.
4. Depress the "ENTER"  key.
5. Using the "UP"  or "DOWN"  buttons, adjust the cut-in pressure until the desired pressure is displayed on the LCD screen.
6. Depress the "ENTER"  key.
7. Depress both the "UP"  or "DOWN"  keys simultaneously to exit the Programming Mode and return to the Display Mode.

Pressure Transducer Display / Explanation					
Display	Description				Setting
SP1	Switching Point 1 (Cut-Out Pressure) Value Range MBA-MBE, Factory Setting MBE				
RP1	Resetting Point 1 (Cut-In Pressure) Value Range MBA-MBE, Factory Setting MBE – 10%				
SP2	Switching Point 2 (Not Used) Value Range MBA-MBE, Factory Setting MBE				MBE
RP2	Resetting Point 2 (Not Used) Value Range MBA-MBE, Factory Setting MBE – 10%				MBE-10%
EF	Extended Programming Functions				
Extended Programming Functions					
Display	Description	Setting	Display	Description	Setting
UNIT	Display Pressure Unit - Value Range Bar,MPA,KPA,PSI,inHG	PSI*	DISM	Display of Low/High Values in the Display Areas C & E (LoHi) - Value Range SPRP, LoHi	SPRP
OU1	Output 1 Switching Function - Value Range HNO,HNC,FNO,FNC	HNC*	DISU	Display Update - Value Range 1/2/5/10 per Second	5 Sec
RES	Rest the parameters to the factory settings (Value Range: Yes/No)	No	DISR	Electronically Invert Each Display Field - Value Range YES,NO	-
DS1	Switching Delay 1 - Value Range 0-50	1.5*	HIGH	Display of Maximum Applied Pressure - Value Range No options	MBA
DR1	Reset Delay 1 - Value Range 0-50	8*	LOW	Display of Minimum Applied Pressure - Value Range No options	MBE
DS2	Switching Delay 2 - Value Range 0-50	0	RHL	Reset High and Low Values - Value Range YES,NO	-
DR2	Reset Delay 2 - Value Range 0-50	0	PAS	Password for Display Lock - Password "0000" = No Password Entry Required- Value Range	-
P-N	Outputs Switching Logic - Value Range PNP/NPN	PNP	TAG	16 Character alphanumeric Measuring Point number - Value Range	-
END	Return to Display Mode				
OUA	Analog Output <ul style="list-style-type: none"> I – Output Signal 4-20mA INV – Inverted Output Signal 20-4 mA U – 0-10V Output Signal UINV – Inverted 0-10V Output Signal Automatic Detection Depending On Current Ohmic Load AUTO – Non-inverted Output Signals Value Range I,IINV,U,UINV,AUTO 	AUTO	DISC	Color In Display <ul style="list-style-type: none"> OD - Red when Pressure <SP (Cut-Out), Green when Pressure >SP (Cut-Out) DU - Red when Pressure >SP (Cut-Out), Green when Pressure <SP (Cut-Out) RED - Always Red GRN – Always Green OFF – Display Off (Power Saving) Value Range OD,DU,RED,GRN,OFF	OD

* Controller programming functions variations from default settings

Pressure Transducer Error and Warning Messages		
OL - OVERPRESS	Applied Pressure > End of Measuring Range	Set Pressure within the Measuring Range
UL - UNDERPRESS	Applied Pressure > Start of Measuring Range	
ERR1 - GEN.ERROR	General Error	Contact Johnson Controls
ERR2 - SHORTOUT1	Short Circuit Present Output 1	Rectify Short-Circuit and Disconnect Supply Voltage Temporarily to Return Outputs to Normal Operation
ERR2 - SHORTOUT2	Short Circuit Present Output 2	
ERR3 - OVERVOLTG	Supply Voltage >30 VDC ¹	Correct Power Supply Voltage
ERR4 - LOWVOLTG	Supply Voltage <17 VDC ¹	
ATT1 - SHIFT RP1	Switching Point is Set Below Existing Resetting Point. The Resetting Point is Automatically Set with Smallest Possible Hysteresis Below New Switching Point	Press ◊ Button to Acknowledge Message
ATT1 - SHIFT RP2		
ATT2 – ADJ>LIMIT	During Zero Point Adjustment, Applied Pressure is Outside Permissible Limits of 5% of the Range	Press ◊ Button to Acknowledge Message
LOCK - KEYLOCKED	If Key Lock is Active, System will Attempt to go into Programming Mode	Enter Password

¹ The Outputs Switch Off if the Supply Voltage Exceeds 30VDC or Falls Below 17VDC

TYCO Nitrogen Generator Filters

The wall-mount nitrogen generator models contain three (3) separate cartridge filters and a water separator. **It is recommended that each filter be replaced at a minimum as part of an annual preventative maintenance program.** Johnson Controls offers a replacement filter kit for each model. When maintained properly the nitrogen separation membrane will have an expected service life of twenty (20) years.

Differential pressure indicators are included on the center and left filter housings to provide a visual indication when the cartridge filters are dirty and need replacement. The filter housings have a “Green” area near the base of the top of the housing to indicate flow through the filter housing.

The visual indications are:

- Indicator with “Green” area displayed - Air flow through the generator filters is acceptable.
- Indicator with “Green” area NOT displayed - cartridge filters are dirty and filters need to be replaced immediately.

Johnson Controls recommends that all cartridge filters (Filters 1,2 & 3) in the nitrogen generator be replaced once a the “Green” indication is not displayed.

Filter Replacement Kit Installation Instructions

(Filter Replacement Kit for the Wall-Mount Nitrogen Generators)

Kit Contents:

Filter Description	Location	Qty.
5-Micron Coalescing Filter	Right Filter Housing - White	1
1-Micron Coalescing Filter	Center Filter Housing - White	1
.01-Micron Coalescing Filter	Left Filter Housing - White	1

**Water Separator should be inspected and cleaned during any filter change.*

NOTE: Before beginning the filter replacement process, **ensure all internal components are cool to the touch.** Components can be very hot after long run cycles and can present risk of injury.

Replacement Guide:

1. Turn off power to nitrogen generator.



2. Verify that all pressure has been drained from inlet line by examining pressure gauge on nitrogen separation membrane inlet.



3. Remove filter housing by depressing the blue housing lock and turning filter housing counter-clockwise.



4. Remove black plastic filter plate underneath filter by turning counter-clockwise. Remove the old coalescing filter from the filter housing.

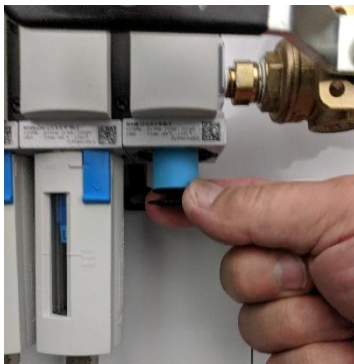

5. Replace with new 5-Micron Coalescing Filter Element, re-install black filter plate, re-install lower section of filter housing.

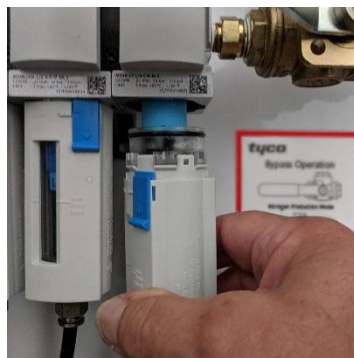

6. Repeat this process for 1-Micron and .01-Micron filters adjacent to 5-Micron filter, using the kit contents table as a guide to match the filters with the correct housings. Be very careful to do this process **one filter at a time** to ensure the filters do not get mixed in the process.

NOTE: The 1-Micron and .01-Micron Filters do not include black plastic filter plate and screw directly into the top of the housing.

.01-Micron Coalescing 1-Micron Coalescing
5-Micron Coalescing



7. Restore power to the nitrogen generator.

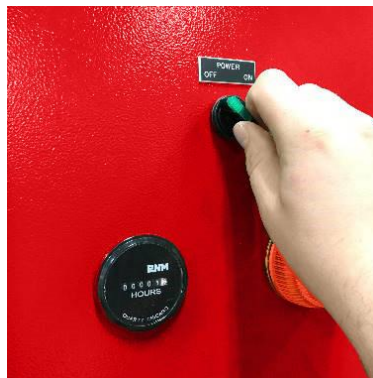

For further filter replacement orders, contact Johnson Controls. Visit the CONTACT US page at www.tyco-fire.com for the contact information by location.

TYCO Oxygen Removal Vent (TAV-D / TSV-D)

Maintenance Instructions

1. TAV-D Manual Vent - The TYCO Vents must be inspected annually at minimum. While isolation ball valve is in the open position, check for air/water leaks and ensure the pressure gauge is displaying normal system pressure.
2. TSV-D SMART Vent - The TYCO Vents must be inspected annually at minimum. While isolation ball valve is in the open position and the VENT button is illuminated, check for air/water leaks and ensure the pressure gauge is displaying normal system pressure.
3. TAV-D / TSV-D Vents - While isolation ball valve is in the closed position the inspection must include the condition of the in-line filter, and blockage in the “Y” strainer and restricted venting orifice. Depressurize the in-line filter housing by pressing the Schrader valve on the bottom of the housing. Twist the black filter housing clockwise until it can be removed to expose the filter element.
4. TAV-D / TSV-D Vents - The filter element in the in-line filter should be replaced if a visual inspection reveals a significant collection of debris.

In-Line Filter Replacement Instructions

1. Close the isolation ball valve.
2. Depressurize the housing by pressing the Schrader valve on the bottom of the in-line filter housing.
3. Remove the lower section of the in-line filter housing by turning the filter housing counterclockwise.

NOTE: A rubber o-ring/seal is located between the upper and lower sections of the filter housing.

4. Remove the old filter by turning the filter counterclockwise.
5. Replace with new filter (TVDFLT). The filter is secured to the housing by turning the filter clockwise.

NOTE: Ensure the filter is secured only finger/hand tight.

6. Install the rubber o-ring/seal on the lower section of the filter housing.
7. Re-install the filter housing by turning the filter housing clockwise.

NOTE: Ensure the filter housing is secured only finger/hand tight.

8. Open the isolation ball valve.

NG-1 100 / NG-1 250 Wall-Mount Generator Configuration

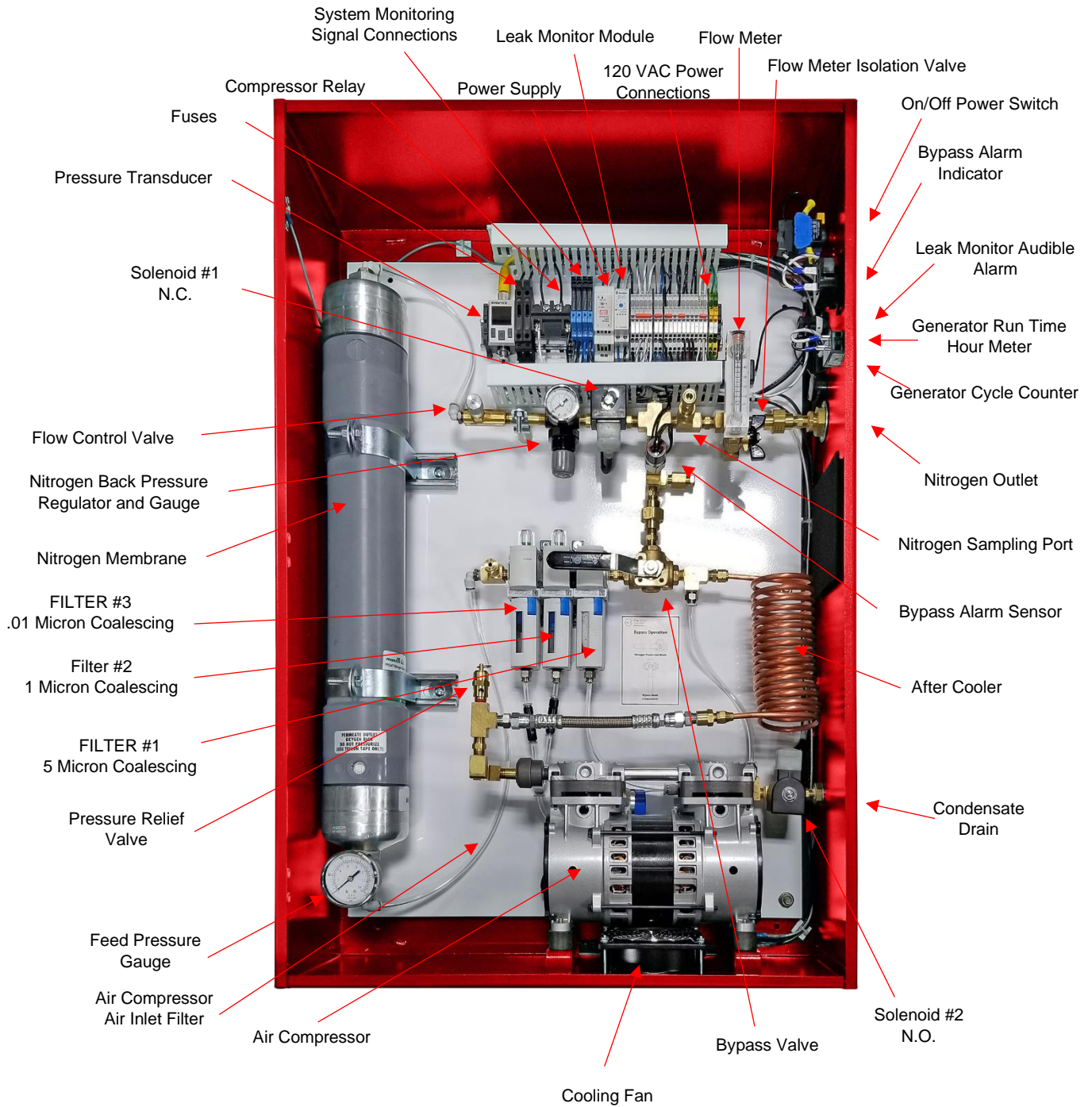

Troubleshooting

SAFETY WARNING

All troubleshooting is to be performed by qualified personnel. Prior to any system troubleshooting on the nitrogen generation system, ensure that the nitrogen generator is isolated from the compressed air supply and all system risers. Be aware of pressurized system components as some of the troubleshooting procedures require system components to be pressurized. Failure to do so can result in system damage and/or personal injury.

SYMPTOM	PROBLEM	RESOLUTION
Nitrogen generator not running	No lights or indicators on generator	Check incoming power and fuses in nitrogen generator
Nitrogen generator not running	Generator lights and indicators on	The nitrogen generator may be in the depressurizing phase of the breathing cycle. When sprinkler system reaches the generator cut-in pressure, the nitrogen generator will automatically turn on. (normal operation)
		Check status of solenoids/angle seat valves in generator. <ul style="list-style-type: none"> • Solenoids should be energized (LED on) when running • Angle Seat Valve should be energized (center pin out) when running. Check system pressure: <ul style="list-style-type: none"> ○ If system pressure above cut-in pressure of generator, reduce system pressure below cut-in pressure and check generator operation. ○ If system pressure below cut-in pressure of generator, check power to air compressor.
Nitrogen not flowing in sprinkler system	Verify nitrogen generator is not in by-pass mode	Place nitrogen generator in nitrogen generation mode.
	While the nitrogen generator running, use a gas analyzer to measure the nitrogen output quality. (See Commissioning / Maintenance Section)	If the nitrogen reading is below 97%, contact Johnson Controls.
	While the nitrogen generator running, measure generator production flow rate through flow meter. (See Commissioning / Maintenance Section)	Compare generator production rate to system commissioning documentation and/or factory test report. If significantly lower, contact Johnson Controls.
Nitrogen generator is short cycling	Pressure on generator digital display decreases after generator shuts off with sprinkler system AMD open.	Close inlet to sprinkler system AMD, if pressure continues to decrease, check for leaks in generator cabinet and supply line.
	With AMD closed, the pressure on generator digital display remains constant after generator shuts off.	<ul style="list-style-type: none"> • AMD partially opening allowing minimal nitrogen flow to sprinkler system results in generator short cycling. Adjust, repair or replace AMD as necessary. • Verify the AMD pressure is 3-5 psig (.2-.3 bar) <u>above</u> nitrogen generator cut-in pressure. Adjust as necessary • Adjust the Short Cycling Prevention Regulator
Air compressor is short cycling	Air compressor short cycles with the nitrogen generator in the standby mode	Check supply line from air compressor to nitrogen generator for leaks.
	Nitrogen generator remains on while air compressor short cycles	<ul style="list-style-type: none"> • Verify the excess air regulator pressure is set 5-10 psig (.3-.7) below air compressor cutout pressure. Adjust as necessary. Air compressor should continue to operate until nitrogen generator shuts off. (See Commissioning / Maintenance Section) • Verify production flow rate and nitrogen purity levels
Nitrogen generator running continuously or running more than 4 hours	Generator in nitrogen generation mode with AMD <u>open</u> and unable to pressurize sprinkler system.	Close AMD. If system supply line pressurizes, check sprinkler system for leaks or inoperable AMD (AMD not automatically closing).

Wiring Diagram

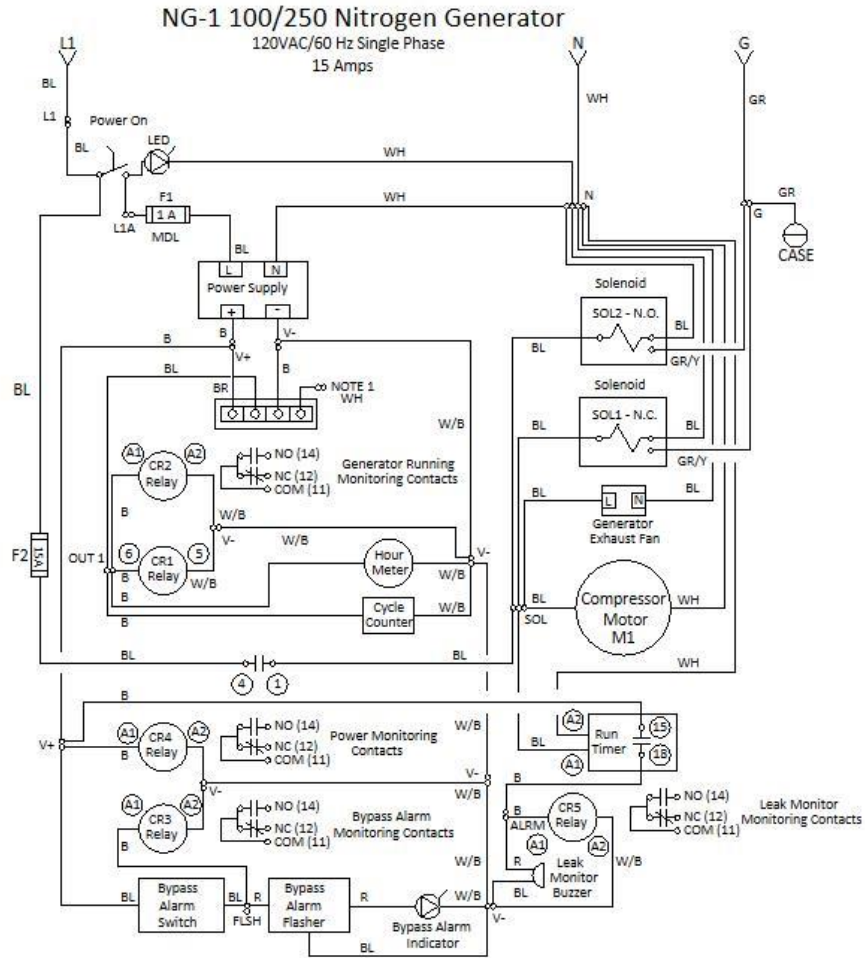

WIRING NOTES:

- AC WIRING 14 AWG. AFTER FUSE
- DC WIRING BLUE+ WHT BLUE TRACER - 16 AWG.
- GROUND GREEN
- USE COPPER CONDUCTORS ONLY
- FIELD WIRING TEMPERATURE RATING: 60° C (140° F)
- USE TERMINAL BLOCKS AS REQUIRED
- REQUIRED FIELD WIRING TERMINAL TIGHTENING TORQUE: 14 IN. LBS.
- 120 VAC/15 AMP CIRCUIT BREAKER TO BE PROVIDED BY INSTALLER AS MEANS OF BRANCH CIRCUIT PROTECTION
- BOND DOORS

WIRING COLOR LEGEND:

BL	BLACK
WH	WHITE
GR	GREEN
B	BLUE
R	RED
W/B	WHITE/BLUE
GR/Y	GREEN/YELLOW
BR	BROWN
GRY	GREY

MONITORING NOTES:

- 1 OPTIONAL 4-20 MA OR 1-10VDC OUTPUT. CONNECT BETWEEN WHITE WIRE AND V-
- 2 OPTIONAL NITROGEN GENERATOR RUNNING MONITORING OUTPUT. (CONTACTS SHOWN ENERGIZED IN NITROGEN RUNNING MODE)
- 3 OPTIONAL BYPASS ALARM MONITORING OUTPUT. (CONTACTS SHOWN ENERGIZED IN BYPASS MODE)
- 4 OPTIONAL POWER MONITORING OUTPUT. (CONTACTS SHOWN ENERGIZED)
- 5 OPTIONAL RUN TIMER MONITORING OUTPUT. (CONTACTS SHOWN DE-ENERGIZED NORMALLY)

ALARM INDICATOR OPERATION

FLASHING INDICATOR - NITROGEN GENERATOR IN BYPASS MODE
BUZZER ACTIVATED - SYSTEM LEAK MONITOR - EXCESSIVE RUN TIME

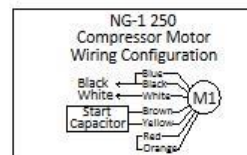
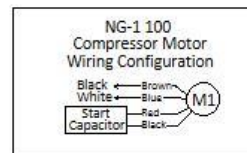

NG-1 100E/250E Nitrogen Generator

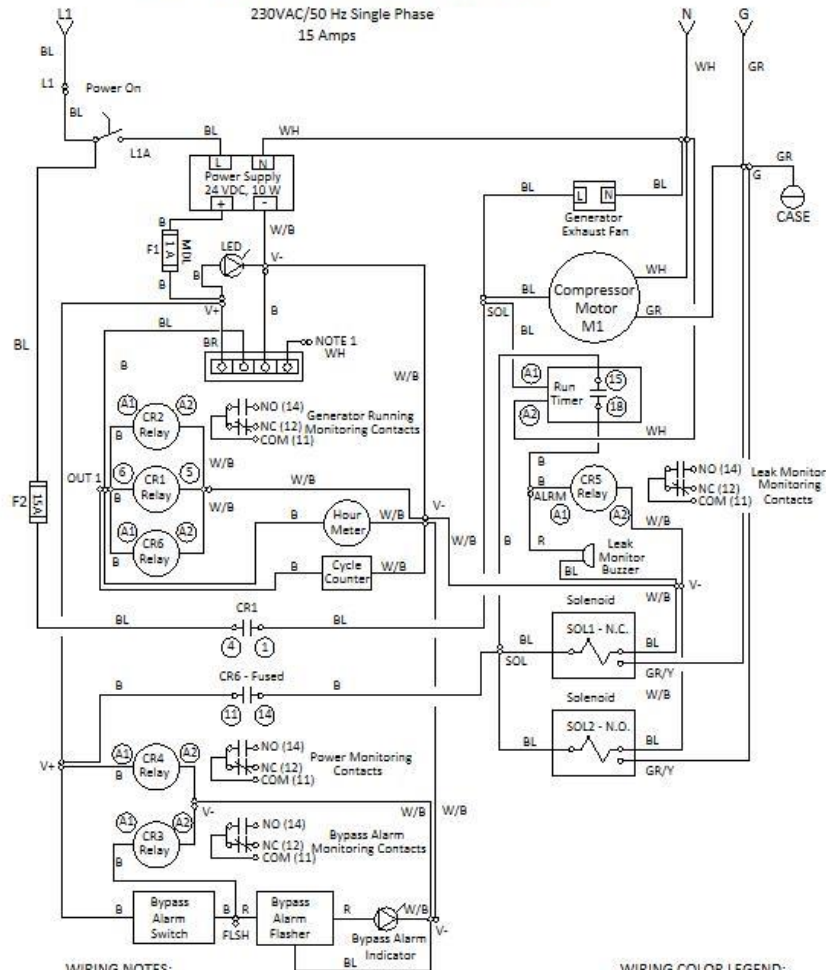

WIRING NOTES:

AC WIRING 14 AWG. AFTER FUSE
 DC WIRING BLUE+ WHT BLUE TRACER - 16 AWG.
 GROUND GREEN
 USE COPPER CONDUCTORS ONLY
 FIELD WIRING TEMPERATURE RATING: 60° C (140° F)
 USE TERMINAL BLOCKS AS REQUIRED
 REQUIRED FIELD WIRING TERMINAL TIGHTENING TORQUE: 14 IN. LBS.
 120 VAC/15 AMP CIRCUIT BREAKER TO BE PROVIDED BY INSTALLER
 AS MEANS OF BRANCH CIRCUIT PROTECTION
 BOND DOORS

MONITORING NOTES:

- 1 OPTIONAL 4-20 MA OR 1-10VDC OUTPUT.
(CONNECT BETWEEN WHITE WIRE AND V-)
- 2 OPTIONAL NITROGEN GENERATOR RUNNING MONITORING OUTPUT.
(CONTACTS SHOWN ENERGIZED IN NITROGEN RUNNING MODE)
- 3 OPTIONAL BYPASS ALARM MONITORING OUTPUT.
(CONTACTS SHOWN ENERGIZED IN BYPASS MODE)
- 4 OPTIONAL POWER MONITORING OUTPUT.
(CONTACTS SHOWN ENERGIZED)
- 5 OPTIONAL RUN TIMER MONITORING OUTPUT.
(CONTACTS SHOWN DE-ENERGIZED NORMALLY)

ALARM INDICATOR OPERATION

FLASHING INDICATOR - NITROGEN GENERATOR IN BYPASS MODE
 BUZZER ACTIVATED - SYSTEM LEAK MONITOR - EXCESSIVE RUN TIME

WIRING COLOR LEGEND:

BL	BLACK
WH	WHITE
GR	GREEN
B	BLUE
R	RED
W/B	WHITE/BLUE
GR/Y	GREEN/YELLOW
BR	BROWN
GRY	GREY

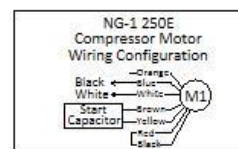
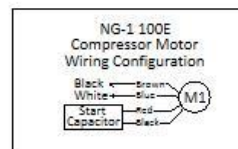

Tyco SMART Gas Analyzer

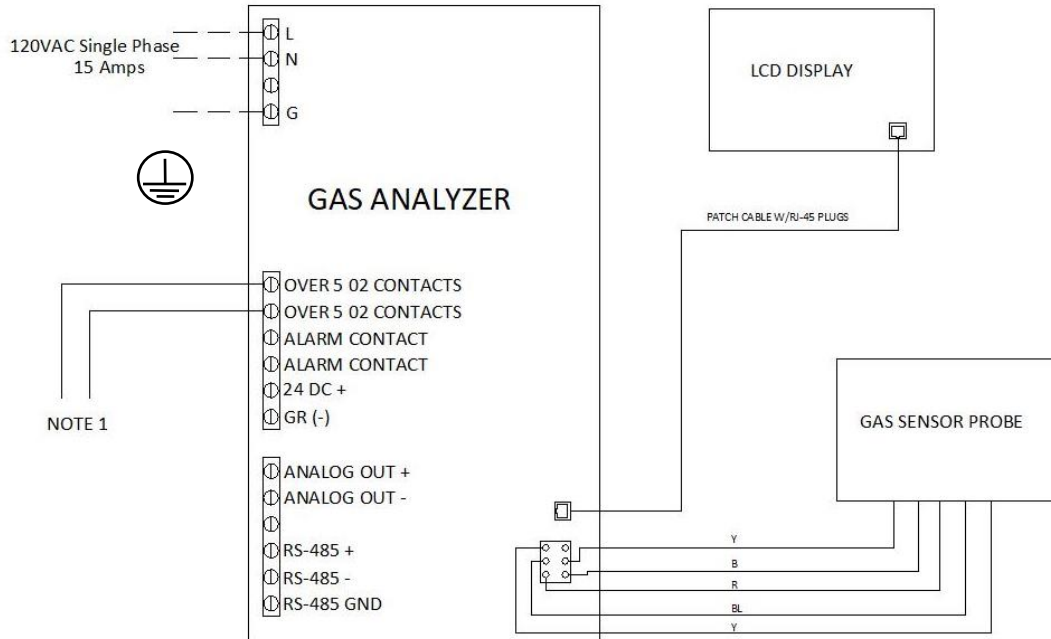

WIRING NOTES:

AC WIRING 14 AWG. AFTER FUSE
 GROUND GREEN
 USE COPPER CONDUCTORS ONLY
 FIELD WIRING TEMPERATURE RATING: 60° C (140° F)
 USE TERMINAL BLOCKS AS REQUIRED
 REQUIRED FIELD WIRING TERMINAL TIGHTENING TORQUE: 14 IN. LBS.
 120 VAC/20 AMP CIRCUIT BREAKER TO BE PROVIDED BY INSTALLER
 AS MEANS OF BRANCH CIRCUIT PROTECTION
 BOND DOORS

WIRING COLOR LEGEND:

BL	BLACK
WH	WHITE
GR	GREEN
B	BLUE
W/B	WHITE/BLUE
GR/Y	GREEN/YELLOW
BR	BROWN
GRY	GREY

INCOMING POWER SOURCE NOTE:

OPERATES AT 120 VAC 60 HZ/240 VAC 50 HZ

NOTE - WHEN TSV-D IS USED INCONJUNCTION WITH TSGA

- CONNECT TERMINALS 8 & 11 TO OUTPUT SIGNAL OF SMART GAS ANALYZER (TSGA) TO BYPASS THE LOW PURITY ALARM SIGNAL DURING THE 14 DAY NITROGEN INERTING PROCESS. (SEE INERTING BYPASS WIRING DIAGRAM)

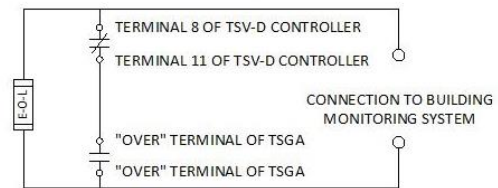

INERTING BYPASS SIGNAL WIRING DIAGRAM

Tyco SMART Gas Analyzer (E)

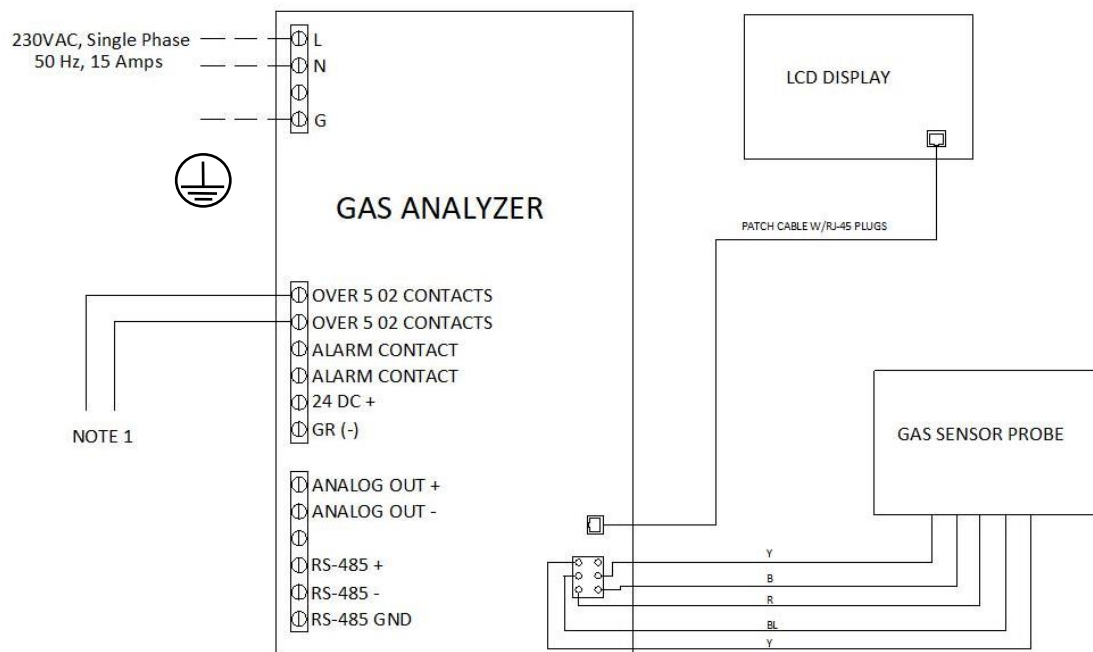

WIRING NOTES:

AC WIRING 14 AWG. AFTER FUSE
 GROUND GREEN
 USE COPPER CONDUCTORS ONLY
 FIELD WIRING TEMPERATURE RATING: 60° C (140° F)
 USE TERMINAL BLOCKS AS REQUIRED
 REQUIRED FIELD WIRING TERMINAL TIGHTENING TORQUE: 14 IN. LBS.
 120 VAC/20 AMP CIRCUIT BREAKER TO BE PROVIDED BY INSTALLER
 AS MEANS OF BRANCH CIRCUIT PROTECTION
 BOND DOORS

WIRING COLOR LEGEND:

BL	BLACK
WH	WHITE
GR	GREEN
B	BLUE
W/B	WHITE/BLUE
GR/Y	GREEN/YELLOW
BR	BROWN
GRY	GREY

INCOMING POWER SOURCE NOTE:

OPERATES AT 120 VAC 60 HZ/240 VAC 50 HZ

NOTE - WHEN TSV-DE IS USED INCONJUNCTION WITH TSGA

- CONNECT TERMINALS 8 & 11 TO OUTPUT SIGNAL OF SMART GAS ANALYZER (TSGA) TO BYPASS THE LOW PURITY ALARM SIGNAL DURING THE 14 DAY NITROGEN INERTING PROCESS. (SEE INERTING BYPASS WIRING DIAGRAM)

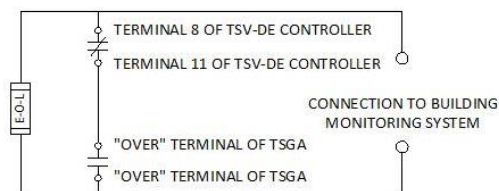

INERTING BYPASS SIGNAL WIRING DIAGRAM

Replacement Filters

PART #	REPLACEMENT FILTERS
TYCO Wall-Mount Nitrogen Generator (NG-1 100/250/500)	
TNGFLTW	TYCO Filter Maintenance Kit - Annual
TYCO Skid-Mount Nitrogen Generator (NG-1 1000) & Stand-Alone Generators (NG-1 1150/1500/2000/3000)	
TNGFLT5	TYCO Filter Maintenance Kit - Annual
TYCO Oxygen Removal Vent	
TVDFLT	Oxygen Removal Vent Filter – Clear Housing

Commissioning Checklist

Fire Sprinkler System - General

Verify and document the quantity of dry/preaction fire sprinkler systems connected to the nitrogen generator: Yes Qty. _____

Verify and document the capacity of each dry/preaction fire sprinkler systems connected to the nitrogen generator (gallons or sq. ft.): Yes

Sys. #1 _____	Sys. #9 _____	Sys. #17 _____
Sys. #2 _____	Sys. #10 _____	Sys. #18 _____
Sys. #3 _____	Sys. #11 _____	Sys. #19 _____
Sys. #4 _____	Sys. #12 _____	Sys. #20 _____
Sys. #5 _____	Sys. #13 _____	Sys. #21 _____
Sys. #6 _____	Sys. #14 _____	Sys. #22 _____
Sys. #7 _____	Sys. #15 _____	Sys. #23 _____
Sys. #8 _____	Sys. #16 _____	Sys. #24 _____

Verify and document the make and model of air maintenance device(s): _____

Verify and document the pressure settings of the air maintenance device(s): _____

Verify and document the Systems(s) High Air Alarm Pressure: _____

Verify and document the Systems(s) Low Air Alarm Pressure: _____

Verify and document the Systems(s) Trip Pressure: _____

Verify and document the make and model of accelerator: _____

Air Compressor - Existing

Verify and document the location of the air compressor: _____

Verify and document the manufacturer of the air compressor: _____

Verify and document the model number of the air compressor: _____

Verify and document the serial number of the air compressor: _____

Verify and document the air compressor on/off pressure settings: _____

Verify and document if an air compressor exists and whether the existing air compressor(s) to remain:

Yes No

If existing Yes: Primary Backup Meet NFPA 13 30-Minute Fill Requirement

Verify and document whether the fire sprinkler system(s) are supplied by house air: Yes No

If Yes, what pressure: _____

Pre-Engineered Nitrogen Generator Equipment

Verify and document the location of the nitrogen generator(s): _____

Verify and document the quantity of the nitrogen generator(s): _____

Verify and document the model number of the nitrogen generator(s): _____

Verify and document the serial number of the nitrogen generator(s): _____

Verify and document whether the nitrogen generator(s) is/are installed correctly: Yes No

If No, explain: _____

Verify and document whether the nitrogen generator(s) is/are wired correctly: Yes No

If No, explain: _____

Programming of nitrogen generator's Pressure Transducer

Turn On/Off Power Switch to the "On" position

Verify and document the cut-in or turn-on pressure of the nitrogen generator is 3-5 psig (.2-.3 bar) below operating pressure of the dry/preaction fire sprinkler systems' air maintenance device(s): Yes No

If No, change the cut-in or turn-on pressure of the nitrogen generator to be 3-5 psig (.2-.3 bar) below operating pressure of the dry/preaction fire sprinkler systems' air maintenance device(s) using the Pressure Transducer Programming Procedure.

Verify and document that the cut-in or turn-on pressure of the nitrogen generator is above the low air alarm pressure of the dry/preaction fire sprinkler system(s): Yes No

Verify and document the cut-in or turn-on pressure of the nitrogen generator: _____

Verify and document the cut-out or turn-off pressure of the nitrogen generator is 45 psig (3.1 bar) above operating pressure of the dry/preaction fire sprinkler systems' air maintenance device(s): Yes No

If No, change the cut-out or turn-off pressure of the nitrogen generator to be 45 psig (3.1 bar) above operating pressure of the dry/preaction fire sprinkler systems' air maintenance device(s) using the Pressure Transducer Programming Procedure.

Verify and document the cut-out or turn-off pressure of the nitrogen generator: _____

Verify and document that the bypass/nitrogen generation valve is operating properly: Yes No

Verify and document the nitrogen back pressure regulator is set to 80 psig (5.5 bar): Yes No

Change if needed. Document regulator setting: _____

Open the isolation ball valve to the internal flow meter.

Connect the handheld gas analyzer (THGA) to the gas sampling port of the nitrogen generator.

Allow the nitrogen generator to operate in nitrogen production mode for approximately five (5) minutes to ensure proper operating temperature of the nitrogen generator prior to adjusting nitrogen purity or measuring nitrogen production rate.

NOTE: The nitrogen generator will obtain optimum operating pressure faster if the nitrogen generator cabinet door is closed.

Adjust to Flow Control Valve in the nitrogen generator to obtain a nitrogen output purity level of 98%.

Verify and document the nitrogen output purity concentration: _____

Verify and document the nitrogen production rate as indicated on the flow meter: _____

Compare documented nitrogen output purity concentration and nitrogen production rate levels with the Shop Test Report provided in the nitrogen generator.

1. Readjust nitrogen output purity level using Flow Control Valve, as necessary, to obtain nitrogen output purity levels and nitrogen production rate comparable to the Shop Test Report, if discrepancies are significant.
2. If unable to obtain comparable nitrogen output purity levels and nitrogen production rate, contact Johnson Controls. Visit the CONTACT US page at www.tyco-fire.com for contact information by location.

Close the isolation ball valve to the internal flow meter.

Disconnect the handheld gas analyzer (THGA) from the gas sampling port of the nitrogen generator.

Leak check all plumbing throughout the nitrogen generator, include the air supply from the air compressor and the nitrogen supply to the fire sprinkler systems, repair any leaks found.

Verify and document that the no leaks exist in the nitrogen generator, air compressor supply line and fire sprinkler supply line: Yes No

Verify and document bypass/nitrogen generation ball valve in the nitrogen generator is in the nitrogen generation position: Yes No

Oxygen Removal Vents - TAV-D & TSV-D

Verify and document the appropriate orifices for each venting device are available: Yes No

NOTE: Ensure the appropriate orifice is installed in the appropriate vent for each fire sprinkler system.

The restricted venting orifice size is determined by the sprinkler system capacity (gallons). The restricted venting orifice ensures the oxygen removal process is completed in all fire sprinkler systems within the same approximate timeframe and within fourteen (14) days.

TAV-D Manual Oxygen Removal Vent

Verify and document the model and serial number of each oxygen removal vent installed: Yes No

Determine the pressure setting of the backpressure regulator of oxygen removal vent

1. The backpressure regulator setting must be below the cut-in or turn-on pressure of the nitrogen generator and 3-5 psig (.2-.3 bar) above the low air alarm pressure of the fire sprinkler system.

Verify and document the appropriate orifice in the oxygen removal vent: Yes No

Install the appropriate orifice in the oxygen removal vent.

Adjust the backpressure regulator setting on the oxygen removal vent:

1. Open and close the isolation ball valve on the oxygen removal vent to determine the pressure setting of the backpressure regulator.
2. Pull the knob out from the regulator to adjust pressure setting. Turn the knob clockwise to raise the pressure, counter-clockwise to lower the pressure.
3. Repeat process until desired pressure setting is achieved.

NOTE: This process can only be performed when fire sprinkler system is at normal operating pressure.

4. Once the desired pressure has been obtained on the backpressure regulator, push the knob onto the regulator until it clicks into place.

Verify and document the backpressure regulator set point: _____

Verify and document isolation ball valve left in open position: Yes No

TSV-D SMART Oxygen Removal Vent

Verify and document model and serial number of each oxygen removal vent installed: Yes No

Verify and document serial number of each oxygen removal vent control box installed: Yes No

Verify and document that the control box is properly installed: Yes No

If No, explain: _____

Verify and document wiring between the control box and the vent is properly installed: Yes No

If No, explain: _____

Verify the control box timer is programmed properly:

- | | | |
|----------------------------|------------------------------|-----------------------------|
| 1. Mode is set to "E" | <input type="checkbox"/> Yes | <input type="checkbox"/> No |
| 2. Scale is set to "20-60" | <input type="checkbox"/> Yes | <input type="checkbox"/> No |
| 3. Range is set to "10h" | <input type="checkbox"/> Yes | <input type="checkbox"/> No |
| 4. Dial is set to "34" | <input type="checkbox"/> Yes | <input type="checkbox"/> No |

Turn On the control box. Verify and document control box is operating properly: Yes No

If No, explain: _____

Determine the pressure setting of the backpressure regulator of oxygen removal vent.

1. The backpressure regulator setting must be below the cut-in or turn-on pressure of the nitrogen generator and 3-5 psig (.2-.3 Bar) above the low air alarm pressure of the fire sprinkler system.

Verify and document the appropriate orifice in the oxygen removal vent: Yes No

Install the appropriate orifice in the oxygen removal vent.

Adjust the backpressure regulator setting on the oxygen removal vent:

1. Turn on the power switch to the control box and depress the "Vent" button.
2. Open and close the isolation ball valve on the oxygen removal vent to determine the pressure setting of the backpressure regulator.
3. Pull the knob out from the regulator to adjust pressure setting. Turn the knob clockwise to raise the pressure, counter-clockwise to lower the pressure.
4. Repeat process until desired pressure setting is achieved.

NOTE: This process can only be performed when fire sprinkler system is at normal operating pressure.

5. Once the desired pressure has been obtained on the backpressure regulator, push the knob onto the regulator until it clicks into place.

Verify and document the backpressure regulator set point: _____

Verify and document isolation ball valve left in open position: Yes No

DPNI System Training

Sprinkler Contractor present: Yes No If Yes, Name: _____
Phone: _____
Email: _____

Owner/Owner's Rep present: Yes No If Yes, Name: _____
Phone: _____
Email: _____

Discuss the following information with individuals present:

- Description of system components
- Description of system operation
- Start-up procedure
- Johnson Controls contact information
- Basic Troubleshooting
- Re-start procedure (system trip or maintenance)
- Maintenance schedule and procedure

Miscellaneous Items

Take installation photos of the following: Yes No

- Inside of Nitrogen Generator
- Outside of Nitrogen Generator
- Plumbing Configuration
- Air Compressor
- Air Maintenance Device
- Sprinkler Valves
- Accelerator

Verify All sprinkler systems in service: Yes No

Verify the Fire alarm system in service: Yes No

Inspection, Testing, and Maintenance Report

Customer		Date	
Address		Inspector	
City		Customer No.	
State		Contract No.	
ZIP		Inspection No.	

All maintenance is to be performed by qualified personnel. Prior to any system maintenance on the nitrogen generation system, ensure that the nitrogen generator is isolated from the compressed air supply and all system risers. Ensure that the nitrogen generation system and the associated piping that is to be manipulated is completely depressurized prior to performing any maintenance. Failure to do so can result in system damage and/or personal injury.

Sprinkler System Information		(psig)	N/A	Verified
Qty of Systems		AMD Set Pressure		
AMD Manufacturer		Low Air Alarm Pressure		
AMD Model No.		System Trip Pressure		

Nitrogen Generator Air Compressor Information		Cut-In (psig)	Cut-Out (psig)	N/A	Verified
Manufacturer					
Model No.					
Serial No.					

Existing/Backup Air Compressor Information		Cut-In (psig)	Cut-Out (psig)	N/A	Verified
Manufacturer					
Model No.					
Serial No.					

Nitrogen Generator Information		Cut-In (psig)	Cut-Out (psig)	N/A	Verified
Manufacturer					
Model No.					
Serial No.					

Air Compressor – Quarterly Maintenance	Hrs.	N/A	Verified
Verify run time (hours) on air compressor (use nitrogen generator hour meter)			
Verify compressor is turning on/off at low/high pressure			
Verify pressure gauges are in working order (replace as necessary)			
Verify all manual valves fully open and close (repair or replace as necessary)			
Verify all manual valves operate smooth-clean and un-corroded (repair/replace if needed)			
Check air compressor filter(s) (clean or replace as necessary)			
Check electrical connections in control box and pressure switch (repair as necessary)			
Check air compressor and supply piping for leaks (repair as necessary)			
Air Compressor – Splash Lubricated			
Check drive belt and drive belt tension (repair or replace as necessary)			
Replace crankcase oil (3 months or 500 hours whichever comes first)			
Air Compressor – Oil-Less			
Rebuild compressor cylinders (5,000 hours)			

Nitrogen Generator – Quarterly Maintenance		Hrs.	Count:	N/A	Verified
Verify run time (hours) on nitrogen generator – Hour Meter					
Verify cycle count on nitrogen generator – Cycle Counter					
Verify nitrogen generator is turning on/off at low/high pressure					
Verify pressure gauges are in working order (replace as necessary)					
Verify all manual valves fully open and close (repair or replace as necessary)					
Verify all manual valves operate smooth-clean and un-corroded (repair/replace if needed)					
Check coalescing filter gauge(s) (replace filters as necessary)	Indication:				
Check electrical connections in cabinet, control box and pressure switch (repair if needed)					
Verify correct nitrogen purity level out of cabinet sampling port	N ₂ Purity:				
Verify nitrogen production level through cabinet flow meter	SCFH:				
Check nitrogen generator and supply piping for leaks (repair as necessary)					
Nitrogen Generator – Annual Maintenance		Hrs.	Count:	N/A	Verified
Verify run time (hours) on nitrogen generator – Hour Meter					
Verify cycle count on nitrogen generator – Cycle Counter					
Verify nitrogen generator is turning on/off at low/high pressure					
Verify pressure gauges are in working order (replace as necessary)					
Verify all manual valves fully open and close (repair or replace as necessary)					
Verify all manual valves operate smooth-clean and un-corroded (repair/replace if needed)					
Replace coalescing filters					
Check electrical connections in cabinet, control box and pressure switch (repair if needed)					
Verify correct nitrogen purity level out of cabinet sampling port	N ₂ Purity:				
Verify nitrogen production level through cabinet flow meter	SCFH:				
Check nitrogen generator and supply piping for leaks (repair as necessary)					
Nitrogen Vents – Quarterly Maintenance				N/A	Verified
Inspect “Y” strainer for dirt and debris (clean as necessary)					
Inspect vent filter dirt and debris (clean/replace as necessary)					
Verify pressure regulator and gauges are in working order (replace as necessary)					
Verify the pressure regulator closes at the determined set pressure (repair/replace if needed)					
Verify all manual valves fully open and close (repair or replace as necessary)					
Verify all manual valves operate smooth-clean and un-corroded (repair/replace if needed)					
Check electrical connections in control cabinet and solenoid (SMART Vent) (repair if needed)					
Verify correct nitrogen purity level out of vent sampling port	N ₂ Purity:				
Check vent and piping for leaks (repair as necessary)					
Corrosion Monitoring – Quarterly Maintenance				N/A	Verified
Verify corrosion detector has not activated (replace probe/detector if needed)					
Verify remote test station batteries operational (replace if needed)					
Verify all manual valves fully open and close (repair or replace if needed)					
Verify all manual valves operate smooth-clean and un-corroded (repair/replace if needed)					
Check electrical connections on corrosion detector pressure switch & monitoring equipment					
Check device and piping for leaks (repair if needed)					
Permanent Gas Analyzer – Quarterly Maintenance				N/A	Verified
Verify correct nitrogen purity level displayed on Gas Analyzer	N ₂ Purity:				
Check electrical connections in control cabinet (repair if needed)					
Check nitrogen sampling tubing for leaks (repair if needed)					