

# LOG LIGHTER VALVE

# 952 & 954 Series

Item Number  
Submitted:

## SPECIFICATION

Sioux Chief 952 & 954 Series HearthMaster™ log lighter gas ball valves shall be used for controlling fuel gas to log lighters, fire pits, barbecues and other locations where similar type valve is required. Valve shall have a cast brass valve body, chrome plated ball, and P.T.F.E. seats. Log lighter valve shall be AGA/CGA certified, manufactured in compliance with ANSI Z 21.15-92, and UPC listed.

## INSTALLATION

Product installation and system testing shall be in accordance with NFPA 54 and ANSI Z223.1 National Gas Fuel Code. Follow manufacturer's installation instructions carefully. Sioux Chief's log lighter and it's individual shut off valve must be disconnected from the gas supply piping system during any pressure testing of that system at test pressures in excess of 1/2 psig, by closing the gas supply line valve, as required by NFPA 54.

## MATERIALS:

VALVE BODY: Cast brass  
BALL: Chrome plated brass  
SEATS: Polytetrafluoroethylene (P.T.F.E.)

## APPROVED USES:

Sioux Chief HearthMaster log lighter gas ball valves are approved for use with natural gas and liquid propane gas

## CONNECTION:

VALVE INLET/OUTLET: 1/2" FIP thread  
STEM: 3/4" NPSM thread

## BTU RATING:

ANGLE PATTERN: 150,000 BTU/hr. @ 1/2 psig  
STRAIGHT PATTERN: 350,000 BTU/hr. @ 1/2 psig

## TEMPERATURE RATING

Minimum: 32° F / 0° C  
Maximum: 125° F / 51.6° C

## DIMENSIONS:

Overall Height - straight	A: 2 11/16"
Thread Height	B: 1"
Overall Width - straight	C: 2"
Top to Centerline	D: 2 1/16"
Overall Height - angle	E: 3 7/16"
Overall Width - angle	F: 1 13/16"
Side to Centerline	G: 1 5/16"
Valve stem - square	H: 5/16"

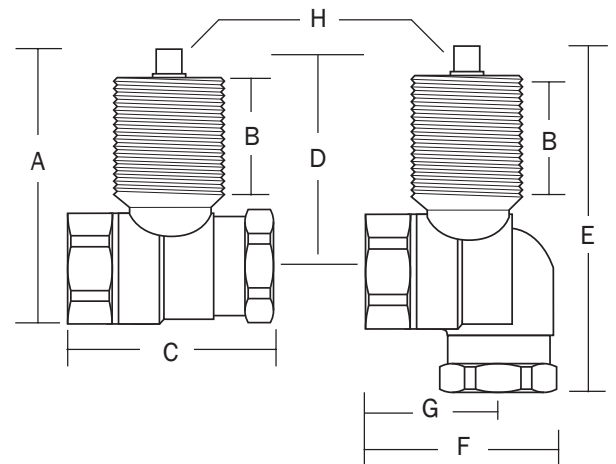
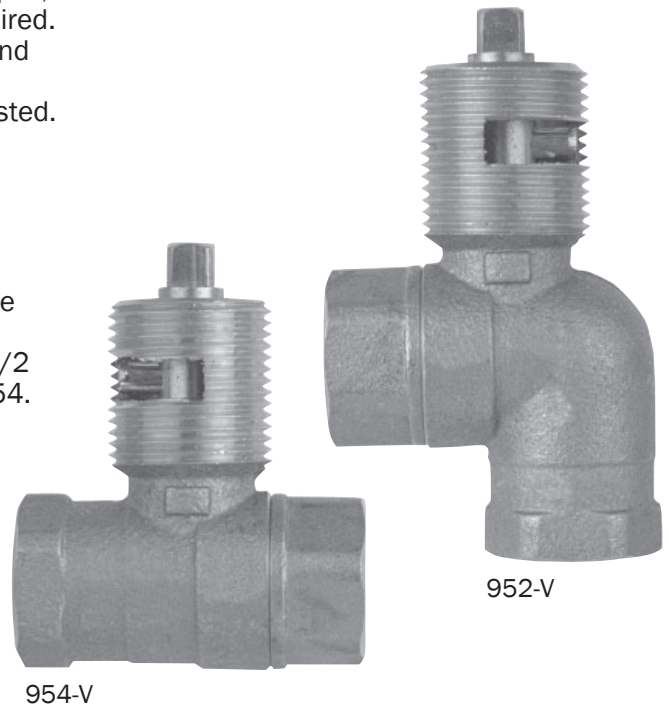

## Create Item Number Below

# 95 A

e.g. 952-V= Angle pattern log lighter gas ball valve

### A Valve pattern

- 2-V Angle pattern valve
- 4-V Straight pattern valve