

SECTION A-A - TYPICAL

H - No. and Size of Holes and Slots Equally Spaced on
 Ø J - Bolt Circle
 2 MJ Ends

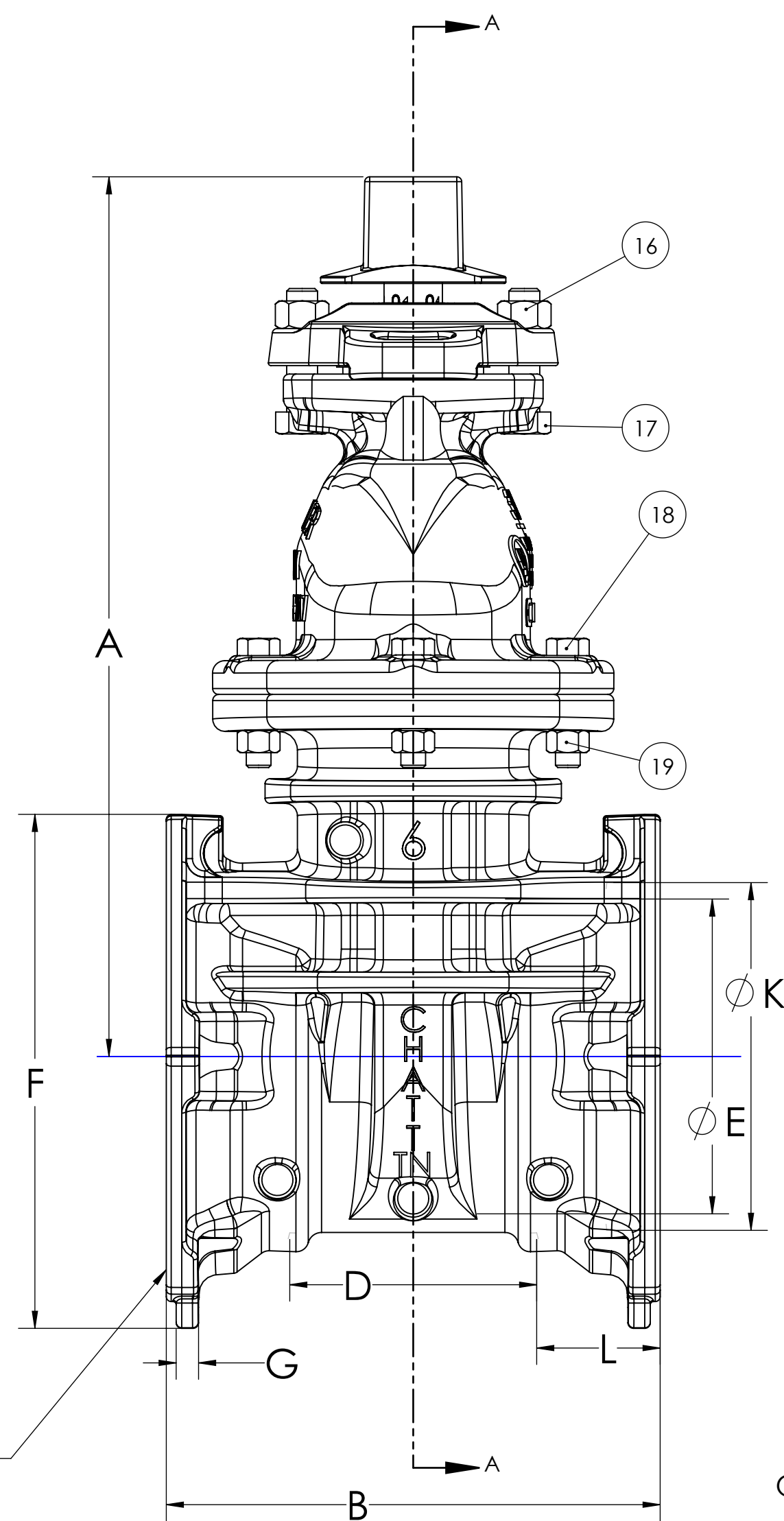

MECH JOINT ENDS - MJ x MJ

Q - No. and Size of Holes and Slots Equally Spaced on
 Ø R - Bolt Circle
 2 FL Ends

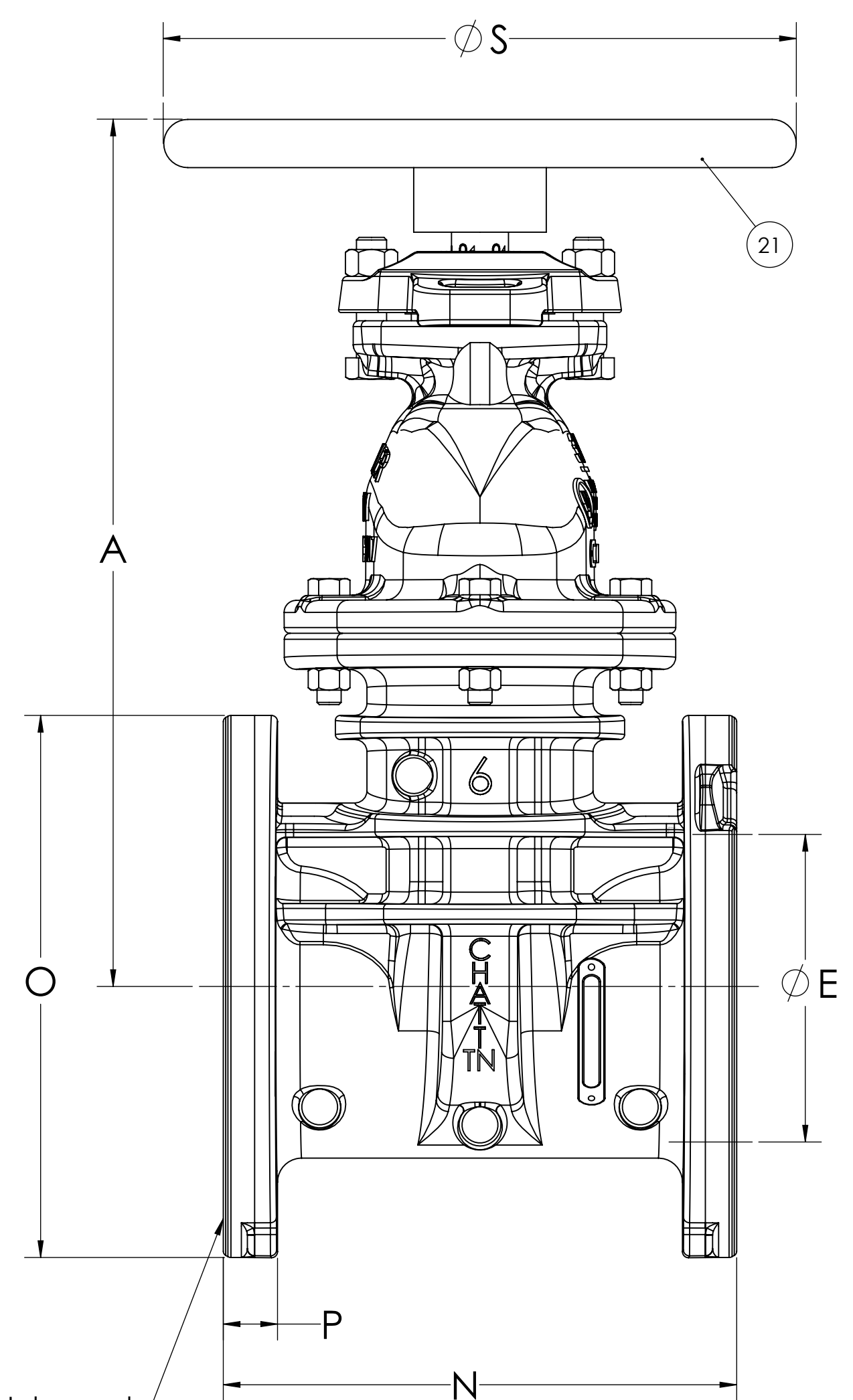

FLANGE ENDS - FL x FL

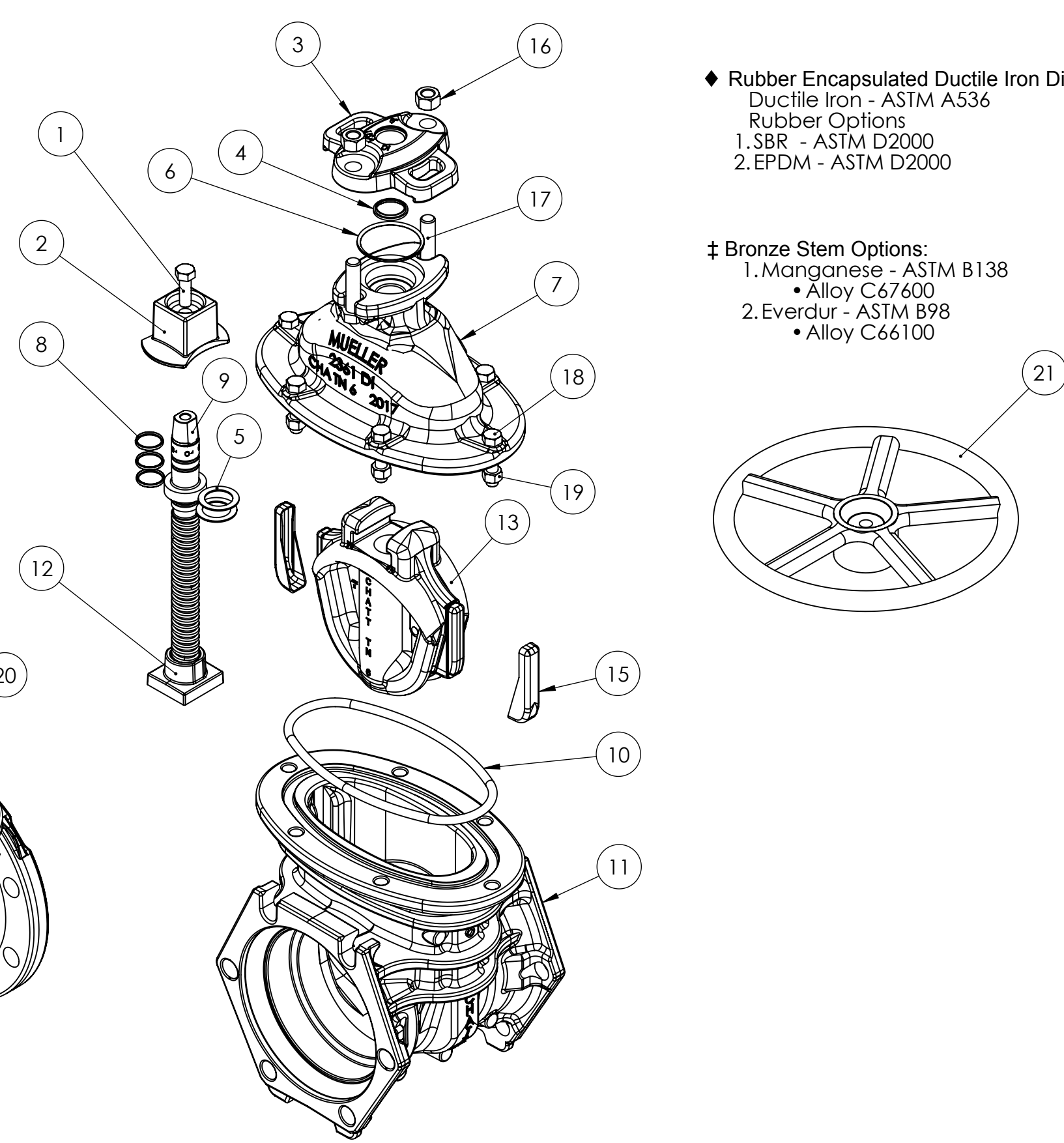

◆ Rubber Encapsulated Ductile Iron Disc
 Ductile Iron - ASTM A536
 Rubber Options
 1. SBR - ASTM D2000
 2. EPDM - ASTM D2000

‡ Bronze Stem Options:
 1. Manganese - ASTM B138
 • Alloy C67600
 2. Everdur - ASTM B98
 • Alloy C66100

ITEM NO.	DESCRIPTION	B. QTY.	MATERIAL	ASTM	NOTES
1	Cap Screw	1		F593	Group 2 - CW
2	Wrench Nut	1	Ductile Iron	A536	
3	Stuffing Box	1	Ductile Iron	A536	
4	Wiper Ring (dirt seal)	1	Thermoplastic Polyurethane	D412/ D624 D2240/D792	HY-52D
5	Anti-friction Washer	2	Acetal		
6	Stuffing Box O-Ring	1	Nitrile Rubber		R34
7	Bonnet	1	Ductile Iron	A536	
8	Stem O-ring	3	Nitrile Rubber		R34
9	Stem	1	Bronze	‡	See Note
10	Bonnet O-ring	1	Nitrile Rubber		R34
11	Body MJ Ends	1	Ductile Iron	A536	
12	Stem Nut	1	Bronze	B584	C89833 / NSF 372
13	Encapsulated Disc	1	◆	D2000	See Note
14	Disc Casting	1	Ductile Iron	A536	
15	Guide Cap	2	Acetal		
18		2	316 Stainless Steel	F594	Group 2 - CW
19	Stuffing Box Bolts	2	316 Stainless Steel	F593	Group 2 - SH
17	Bonnet Bolts	"M"	316 Stainless Steel	F593	Group 2 - SH
16	Bonnet Nuts	"M"	316 Stainless Steel	F594	Group 2 - CW
20	Body FL Ends		Ductile Iron	A536	
21	Handwheel		Ductile Iron	A536	

ECO# 2205739 **APPROVED**
 By MATTHEW SLIGER at 10:20 pm, Oct 10, 2018

Valve Size	A	B	C	D	Ø E (Thru Ø)	F	G	H	Ø J (Bolt Circle Ø)	Ø K	L	M	Turns to Open	Weight MJ x MJ	N	O	P	Q	Ø R (Bolt Circle Ø)	Ø S	Weight FL x FL
4	14.19	9.5	10.79	4.50	4.30	8.40	0.50	4-0.88	7.50	4.90	2.50	4	14	75	9.00	9.00	1.00	8-0.75	7.50	11	85
6	18.00	10	13.5	5.00	6.30	10.41	0.45	6-0.88	9.50	7.00	2.50	6	20.5	124	10.50	11.25	1.13	8-0.88	9.50	13	145
8	21.50	10.5	16.36	5.50	8.30	12.68	0.50	6-0.88	11.75	9.15	2.50	6	26.5	181	11.50	13.50	1.15	8-0.88	11.75	14	208
10	25.50	11.5	20	6.50	10.30	15.24	0.62	8-0.88	14.00	11.20	2.50	8	33	270	13.00	16.00	1.29	12-1.00	14.25	16	310
12	28.62	12	21	7.00	12.30	18.024	0.62	8-0.88	16.25	13.30	2.50	8	38.5	345	14.00	19.00	1.33	12-1.00	17.00	16	420

MUELLER CONFIDENTIAL
 TITLE TO AND OWNERSHIP OF THIS ENGINEERING DATA REMAINS IN MUELLER CO. NO USE IS TO BE MADE OF THIS DATA EXCEPT AS SPECIFICALLY AUTHORIZED BY MUELLER CO. ASSENT ON THE PART OF THE RECEIPTS TO THESE CONDITIONS IS PRESUMED.

UNLESS OTHERWISE SPECIFIED: DIMENSIONS ARE IN INCHES TOLERANCES.
 ANGULAR: ± TWO DECIMAL: ± THREE DECIMAL: ±



MATERIAL SEE TABLE
 FINISH

NAME	JMH	DATE	9/1/2016
CHECKED	AO		
ENG APPR.	MS		
MFG APPR.			
Q.A.			

DESCR. 2361 RWGV 350W w/ 316 Fasteners	
SIZE D	DWG. NO. 7334
SCALE:	WEIGHT (lbs): SEE TABLE
	SHEET 1 OF 1