

## Series TY-L — 5.6 K-factor Horizontal Sidewall Sprinklers Standard Response, Standard Coverage

### General Description

The Series TY-L, 5.6 K-factor, Horizontal Sidewall Sprinklers are standard response - standard coverage, solder type spray sprinklers designed for use in light and ordinary hazard, commercial occupancies such as banks, hotels, shopping malls, offices, etc. They are designed for installation along a wall or the side of a beam and just beneath a smooth ceiling. Horizontal sidewall sprinklers are commonly used instead of pendent or upright sprinklers due to aesthetics or building construction considerations where piping across the ceiling is not desirable.

Corrosion resistant coatings, where applicable, are utilized to extend the life of copper alloy sprinklers beyond that which would otherwise be obtained when exposed to corrosive atmospheres. Although corrosion resistant coated sprinklers have passed the standard corrosion tests of the applicable approval agencies, the testing is not representative of all possible corrosive atmospheres. Consequently, it is recommended that the end user be consulted with respect to the suitability of these coatings for any given corrosive environment. The effects of ambient temperature, concentration of chemicals, and gas/chemical velocity,

#### IMPORTANT

Always refer to Technical Data Sheet TFP700 for the "INSTALLER WARNING" that provides cautions with respect to handling and installation of sprinkler systems and components. Improper handling and installation can permanently damage a sprinkler system or its components and cause the sprinkler to fail to operate in a fire situation or cause it to operate prematurely.

should be considered, as a minimum, along with the corrosive nature of the chemical to which the sprinklers will be exposed.

#### WARNINGS

The Series TY-L Sprinklers described herein must be installed and maintained in compliance with this document, as well as with the applicable standards of the National Fire Protection Association, in addition to the standards of any other authorities having jurisdiction. **Failure to do so may impair the performance of these devices.**

The owner is responsible for maintaining their fire protection system and devices in proper operating condition. The installing contractor or sprinkler manufacturer should be contacted with any questions.

### Model/Sprinkler Identification Numbers

TY3311 - HSW 5.6K, 1/2" NPT

TY3311 is a redesignation for S1803 and G3113.

### Technical Data

#### Approvals

UL and C-UL Listed.  
FM Approved.  
(Refer to Table A for complete approval information.)

#### Maximum Working Pressure

175 psi (12,1 bar)

#### Discharge Coefficient

K = 5.6 GPM/psi<sup>1/2</sup> (80,6 LPM/bar<sup>1/2</sup>)

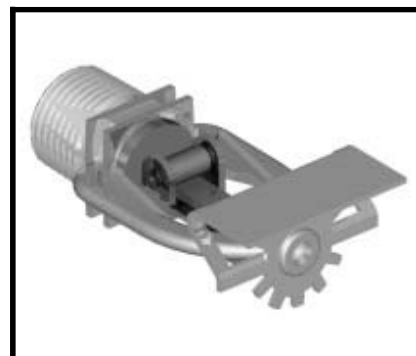

#### Temperature Ratings

Refer to Table A

#### Finishes

Sprinkler: Refer to Table A

#### Physical Characteristics

Frame . . . . .	Brass
Sealing Button . . . . .	Bronze w/Teflon†
Ejection Spring . . . . .	Stainless Steel
Fusible Element . . . . .	Solder, Copper
. . . . .	Stainless Steel
Strut . . . . .	Monel
Hook . . . . .	Bronze/Monel
Deflector . . . . .	Bronze

† DuPont Registered Trademark

### Operation

A copper tube sealed by two stainless steel balls holds a fusible alloy. When the rated temperature is reached, the alloy melts, the balls are forced toward each other releasing the tension mechanism, allowing the sprinkler to operate.

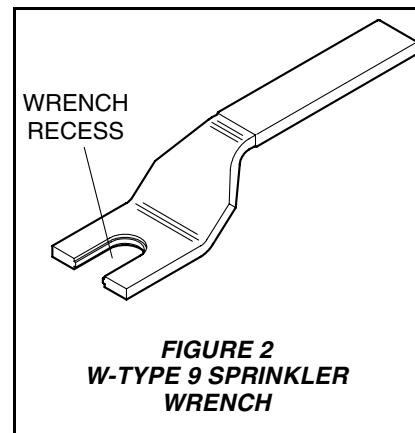
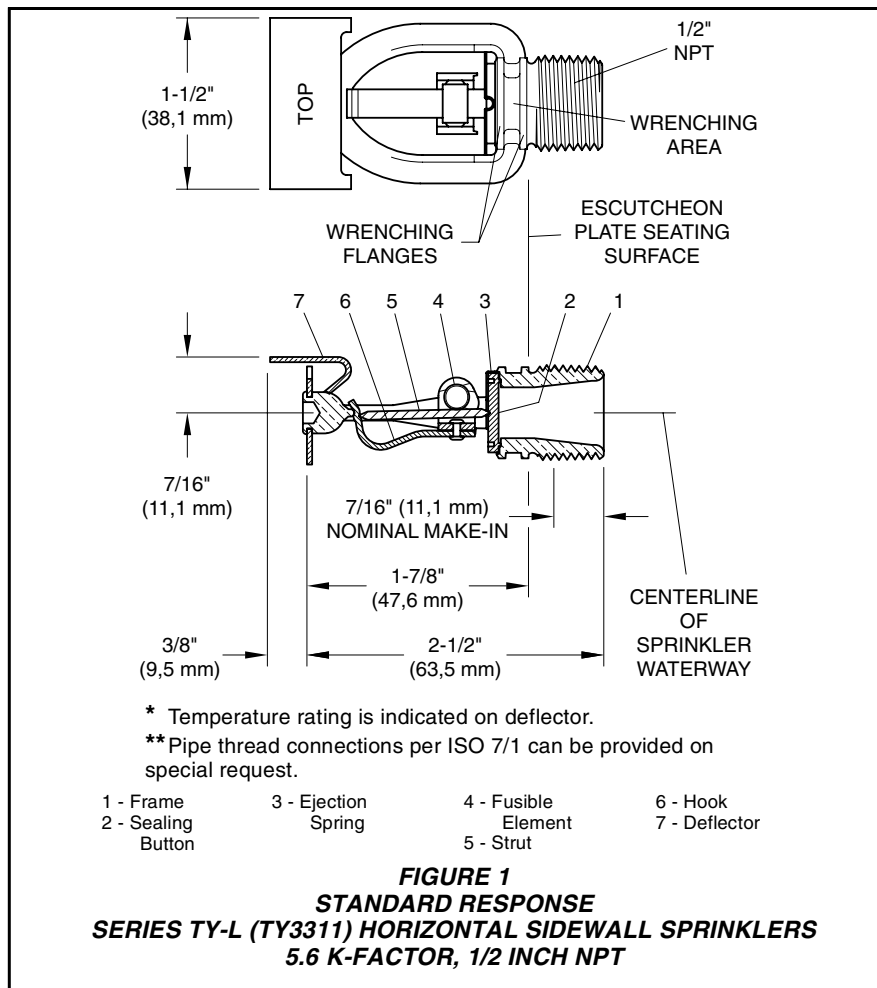

l to the ceiling and perpendicular to the back wall surface. The word "TOP" on the deflector must face upwards toward the ceiling.

**Step 2.** After installing an escutcheon (as applicable) over the sprinkler pipe threads and with pipe thread sealant applied to the pipe threads, hand tighten the sprinkler into the sprinkler fitting.

**Step 3.** Tighten the sprinkler into the sprinkler fitting using only the W-Type 9 Sprinkler Wrench (Ref. Figure 2), except that an 8 or 10 inch adjustable Crescent wrench is to be used for wax coated sprinklers. With reference to Figure 1, the W-Type 9 Sprinkler Wrench is to be applied to the wrench area, or as applicable, the adjustable Crescent wrench is to be applied to the wrenching flanges.

When installing wax coated sprinklers with the adjustable Crescent wrench, additional care needs to be exercised to prevent damage to the wax coating on the sprinkler wrench flats or frame arms and, consequently, exposure of bare metal to the corrosive environment. The jaws of the wrench should be opened sufficiently wide to pass over the wrench flats without damaging the wax coating. Before wrench tightening the sprinkler, the jaws of the wrench are to be adjusted to just contact the sprinkler wrench flats. After wrench tightening the sprinkler, loosen the wrench jaws before removing the wrench.

After installation, the sprinkler wrench flats and frame arms must be inspected and the wax coating re-touched (repaired) whenever the coating has been damaged and bare metal is exposed. The wax coating on the wrench flats can be re-touched by gently applying a heated 1/8 inch diameter steel rod to the areas of wax that have

## Design Criteria

The 5.6 K-factor, Series TY-L Horizontal Sidewall Sprinklers are intended for fire protection systems designed in accordance with the standard installation rules recognized by the applicable Listing or Approval agency (e.g., UL Listing is based on NFPA 13 requirements). The Series TY-L Horizontal Sidewall Sprinkler must be installed with a deflector to ceiling distance of 4 to 6 inches (100 to 150 mm). To meet this requirement the centerline of the sprinkler waterway must be located 4-5/16 to 6-5/16 inches (110 to 160 mm) below the ceiling. Installation of the Series TY-L Horizontal Sidewall Sprinklers in recessed escutcheons will void all manufacturer's warranties, as well as possibly void the sprinkler's Approvals and/or Listings.

## Installation

The Series TY-L Sprinklers must be installed in accordance with the following instructions:

### NOTES

*A leak tight 1/2 inch NPT sprinkler joint should be obtained with a torque of 7 to 14 ft.lbs. (9,5 to 19,0 Nm). A maximum of 21 ft. lbs. (28,5 Nm) of torque may be used to install sprinklers with 1/2 NPT connections. Higher levels of torque may distort the sprinkler inlet and cause leakage or impairment of the sprinkler.*

*Do not attempt to make-up for insufficient adjustment in the escutcheon plate by under- or over-tightening the sprinkler. Readjust the position of the sprinkler fitting to suit.*

The **Series TY-L Horizontal Sidewall Sprinklers** must be installed in accordance with the following instructions.

**Step 1.** The Series TY-L Horizontal Sidewall Sprinklers must be installed with their centerline of waterway paral-

K	TYPE	TEMP. RATING	FRAME COLOR CODE	SPRINKLER FINISH				
				NATURAL BRASS	CHROME PLATED	LEAD COATED	WAX COATED	WAX OVER LEAD COATED
5.6 1/2" NPT	HORIZONTAL SIDEWALL (TY3311)	165°F/74°C	Unpainted	1, 2, 3		1, 2		
		212°F/100°C	White					
		280°F/138°C	Blue					

**NOTES:**

1. Listed by Underwriters Laboratories, Inc. (UL) for Light or Ordinary Hazard Occupancies.
  2. Listed by Underwriters Laboratories, Inc. for use in Canada (C-UL) for Light or Ordinary Hazard Occupancies.
  3. Approved by Factory Mutual Research Corporation (FM) for Light Hazard Occupancies.
- N/A: Not Available.

**TABLE A  
LABORATORY LISTINGS AND APPROVALS**

been damaged, to smooth it back over areas where bare metal is exposed.

**NOTES**

*Only retouching of the wax coating applied to the wrench flats and frame arms is permitted, and the retouching is to be performed only at the time of the initial sprinkler installation.*

*The steel rod should be heated only to the point at which it can begin to melt the wax, and appropriate precautions need to be taken, when handling the heated rod, in order to prevent the installer from being burned.*

*If attempts to retouch the wax coating with complete coverage are unsuccessful, additional wax can be ordered in the form of a wax stick (the end of which is color coded). Only the correct color coded wax is to be used, and retouching of wrench flats and frame arms is only permitted at the time of initial sprinkler installation. With the steel rod heated as previously described, touch the rod to the area requiring additional wax with the rod angled downward, and then touch the wax stick to the rod approximately one-half inch away from the area requiring retouching. The wax will melt and run down onto the sprinkler.*

## Care and Maintenance

The Series TY-L Sprinklers must be maintained and serviced in accordance with the following instructions:

**NOTES**

*Before closing a fire protection system main control valve for maintenance work on the fire protection system that it controls, permission to shut down the affected fire protection system must be*

*obtained from the proper authorities and all personnel who may be affected by this action must be notified.*

*Absence of an escutcheon, which is used to cover a clearance hole, may delay the time to sprinkler operation in a fire situation.*

Sprinklers that are found to be leaking or exhibiting visible signs of corrosion must be replaced.

Automatic sprinklers must never be painted, plated, coated or otherwise altered after leaving the factory. Modified or over-heated sprinklers must be replaced.

Care must be exercised to avoid damage to the sprinklers - before, during, and after installation. Sprinklers damaged by dropping, striking, wrench twist/slippage, or the like, must be replaced.

Frequent visual inspections are recommended to be initially performed for corrosion resistant coated sprinklers, after the installation has been completed, to verify the integrity of the corrosion resistant coating. Thereafter, annual inspections per NFPA 25 should suffice; however, instead of inspecting from the floor level, a random sampling of close-up visual inspections should be made, so as to better determine the exact sprinkler condition and the long term integrity of the corrosion resistant coating, as it may be affected by the corrosive conditions present.

The owner is responsible for the inspection, testing, and maintenance of their fire protection system and devices in compliance with this document, as well as with the applicable standards of the National Fire Protection Association (e.g., NFPA 25), in addition to the standards of any other

authorities having jurisdiction. The installing contractor or sprinkler manufacturer should be contacted relative to any questions.

It is recommended that automatic sprinkler systems be inspected, tested, and maintained by a qualified Inspection Service in accordance with local requirements and/or national codes.

## Limited Warranty

Products manufactured by Tyco Fire Products are warranted solely to the original Buyer for ten (10) years against defects in material and workmanship when paid for and properly installed and maintained under normal use and service. This warranty will expire ten (10) years from date of shipment by Tyco Fire Products. No warranty is given for products or components manufactured by companies not affiliated by ownership with Tyco Fire Products or for products and components which have been subject to misuse, improper installation, corrosion, or which have not been installed, maintained, modified or repaired in accordance with applicable Standards of the National Fire Protection Association, and/or the standards of any other Authorities Having Jurisdiction. Materials found by Tyco Fire Products to be defective shall be either repaired or replaced, at Tyco Fire Products' sole option. Tyco Fire Products neither assumes, nor authorizes any person to assume for it, any other obligation in connection with the sale of products or parts of products. Tyco Fire Products shall not be responsible for sprinkler system design errors or inaccurate or

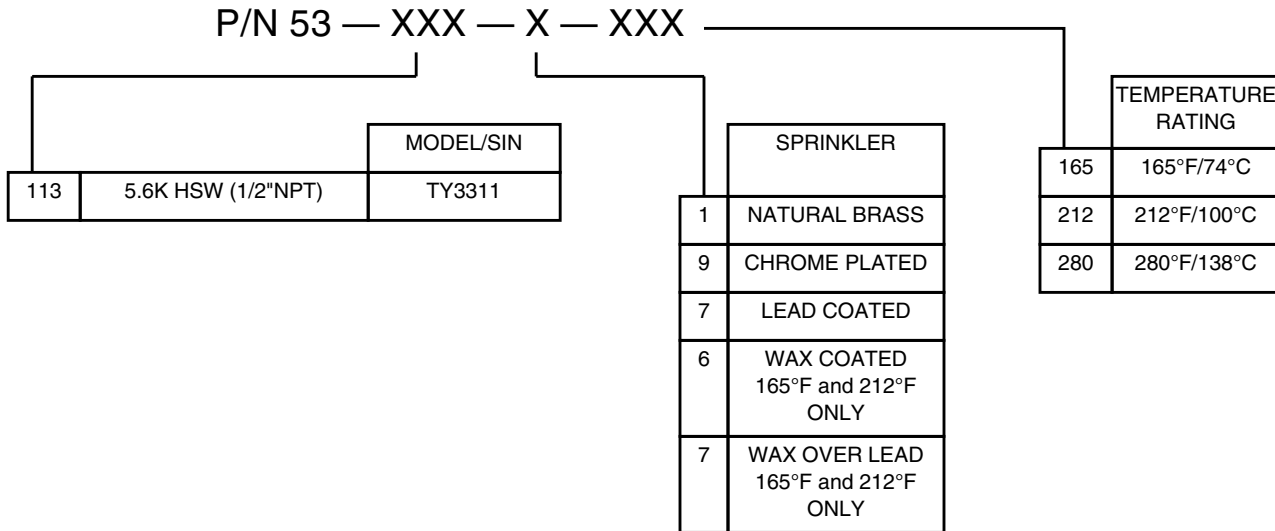

**TABLE B  
PART NUMBER SELECTION  
SERIES TY-L HORIZONTAL SIDEWALL SPRINKLERS**

incomplete information supplied by Buyer or Buyer's representatives.

IN NO EVENT SHALL TYCO FIRE PRODUCTS BE LIABLE, IN CONTRACT, TORT, STRICT LIABILITY OR UNDER ANY OTHER LEGAL THEORY, FOR INCIDENTAL, INDIRECT, SPECIAL OR CONSEQUENTIAL DAMAGES, INCLUDING BUT NOT LIMITED TO LABOR CHARGES, REGARDLESS OF WHETHER TYCO FIRE PRODUCTS WAS INFORMED ABOUT THE POSSIBILITY OF SUCH DAMAGES, AND IN NO EVENT SHALL TYCO FIRE PRODUCTS' LIABILITY EXCEED AN AMOUNT EQUAL TO THE SALES PRICE.

**THE FOREGOING WARRANTY IS MADE IN LIEU OF ANY AND ALL OTHER WARRANTIES EXPRESS OR IMPLIED, INCLUDING WARRANTIES OF MERCHANTABILITY AND FITNESS FOR A PARTICULAR PURPOSE.**

## Ordering Procedure

When placing an order, indicate the full product name. Refer to the Price List for complete listing of Part Numbers.

Contact your local distributor for availability.

### Sprinkler Assemblies with NPT

#### Thread Connections:

Specify: (Specify Model/SIN), Standard Response, (specify K-factor), (specify temperature rating), Series TY-L Horizontal Sidewall Sprinkler with (specify type of finish), P/N (specify from Table B).

#### Sprinkler Wrench:

Specify: W-Type 9 Sprinkler Wrench, P/N 56-000-1-849.

### Wax Sticks: (for retouching wrench damaged wax coating)

Specify: (Specify color) color coded Wax Stick for retouching (specify temperature rating) temperature rated Series TY-L Sprinklers, P/N (specify).

Red for 165°F . . . . . P/N 56-065-1-155  
Blue for 212°F and 280°F . . . . . P/N 56-065-1-286

### NOTES

*Each wax stick is suitable for retouching up to twenty-five sprinklers.*

*The wax used for 280°F sprinklers is the same as for 212°F sprinklers, and, therefore, the 280°F sprinkler is limited to the same maximum ceiling temperature as the 212°F sprinkler (i.e., 150°F).*