



PSP1 Plug-in Special Purpose Supervisory Switch

System Sensor's PSP1 plug-in switch is a special application supervisory switch designed for applications where no other type of listed valve supervisory switch can be used.



Features

- Monitors non-rising stem gate and ball and angle valves
- NEMA 3 rated enclosures
- 360° mounting design provides greater installation flexibility
- Adjustable length supervisory cord
- Lockout feature ensures alarm signal integrity
- Cover tamper switch factory installed
- Tamper-resistant cover screws

Application Flexibility. The PSP1 is to be used on non-rising stem gate valves and ball and angle valves. The unit is approved for Class A and Class B circuits.

Robust Construction. The PSP1 consists of a rugged rain tight metal housing. With its NEMA 3 rated housing and water-resistant cord, the PSP1 may be used in either indoor or outdoor applications.

Simplified Operation. The PSP1 features a 360° versatile mounting design and an adjustable length cord which allow more freedom to install the unit at the most desirable alignment angle.

Reliable Performance. The PSP1 employs a supervisory cord which, when pulled out, closes a set of normally open contacts. A lockout feature prevents reinsertion of the cord until the cover is removed, and the unit is reset. Removal of the cover or cutting of the cord results in an open circuit.

Agency Listings



PSP1 Specifications

Architectural/Engineering Specifications

Model shall be a model number PSP1 special purpose supervisory switch as manufactured by System Sensor. The unit is not intended or designed for ordinary usage. It is a special application device to be used for unusual conditions where no other approved or listed method of protection is available or practical, such as non-rising stem gate valves. When installed on a non-rising stem gate valve, turning the valve wheel will pull the plug out of the jack and close a set of normally open contacts. A lockout will prevent reinsertion and will require removal of the cover. Tamper-proof screws are provided for the cover. Removal of the cover, cutting of the cord, or ground faults will cause an open circuit. The device should be wired to the trouble circuit of a fire alarm control panel. The PSP1 shall be capable of operating on Class A or Class B circuits. The PSP1 shall be NEMA 3 rated for indoor/outdoor use and shall have an operating temperature range of -4°F to 149°F (-20°C to 65°C). The PSP1 shall be listed by Underwriters Laboratories and Underwriters Laboratories of Canada, Inc. and shall be Factory Mutual approved.

Physical/Electrical Specifications

Dimensions	4¾" L x 3" W x 2½" D (12 cm x 7.5 cm x 5.6 cm)
Dimensions with Bracket	8½" L (21.5 cm)
Shipping Weight	1.7 lbs. (0.8 kg)
Operating Temperature Range	-4°F to 149°F (-20°C to 65°C)
Enclosure Rating	NEMA 3 UL Indoor/Outdoor Rated
Cover Tamper Switch	Standard
Cable	2 wire, 18 gauge waterproof, 8 feet long (2.4 m)
Operating Voltage	6/12/24V AC/DC
Maximum Operating Current	250 mA
Warranty	3 years
U.S. Patent Number	6,037,867

PSP1 Wiring: Single Device Class B

Note: No other types of initiating device may be connected to the same FACP initiating circuit

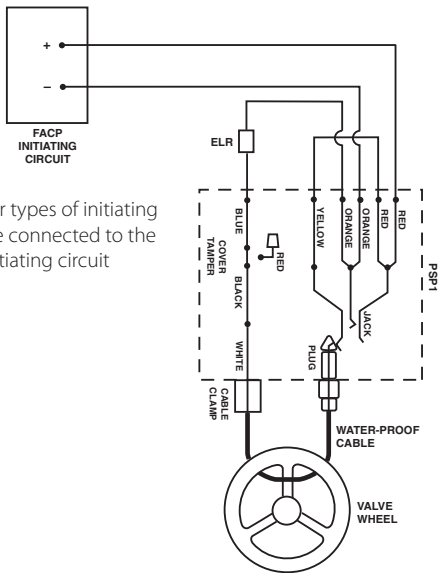

W0167-00

PSP1 Wiring: Single Device Class A

Note: No other types of initiating device may be connected to the same FACP initiating circuit

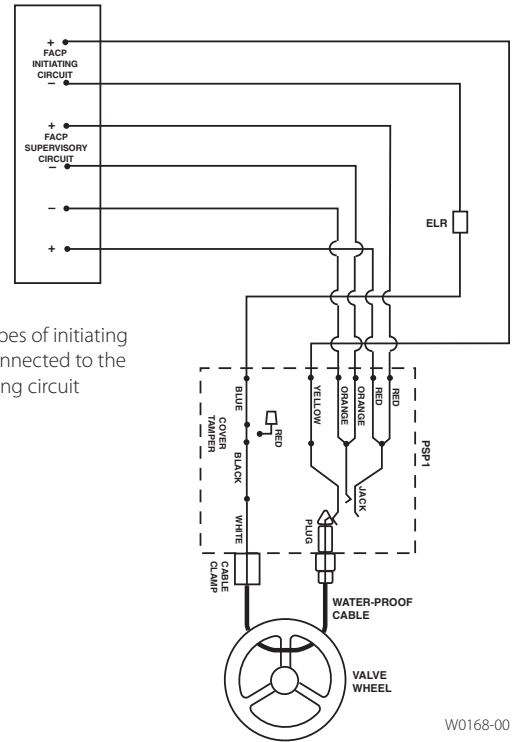

W0168-00

Ordering Information

Part No.	Description
PSP1	Plug-in Special Purpose Supervisory Switch
PSP1A	Plug-in Special Purpose Supervisory Switch (ULC model)



3825 Ohio Avenue • St. Charles, IL 60174
Phone: 800-SENSOR2 • Fax: 630-377-6495

©2007 System Sensor.
Product specifications subject to change without notice. Visit systemsensor.com for current product information, including the latest version of this data sheet.
A05-0972-005 • 3/07 • #1805