

No.	DESCRIPTION	MATERIAL
1	SPUD	CAST LOW LEAD BRASS ALLOY
2	CONN. NUT	CAST BRASS ASTM B62 ALLOY C83600
3	CTS GSKT SUB	SBR ASTM D2000 - GSKT 410ss - BAND

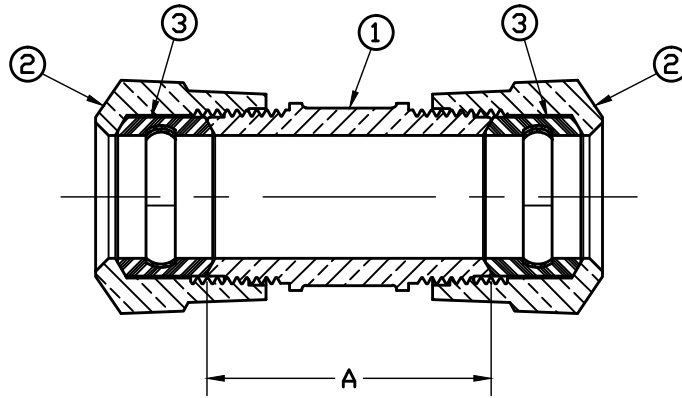

SIZE	A
3/4"	2-1/16"
1"	2-13/32"
1 x 3/4"	1-53/64"
1-1/4"	2-3/8"
1-1/2"	3-5/16"
2"	3-3/8"

FILEPATH: PRODD-ENG\JJ\SUBMITTALS\E2609SG

						DRFTR	RWB	6/9/08	JAMES JONES CO.		
						CHKR					
						ENGR					
						MGR					
							BY	DATE	UNLESS OTHERWISE NOTED	THIRD ANGLE PROJECTION	
									SURFACE PREPARATION:		
									BREAK CORNER(S) ---- .000		
									SURFACE FINISH -- XX RMS	REF. No.	SCALE
									TOLERANCE(S):		
									LINEAR ----- ± .000		
									ANGULAR ----- ± 0°00'		
									STK No:		
									MAT'L:		
									DESCR.		
									STRAIGHT 3-PART UNION SERVICE FITTING		PART NUMBER
									(110 CTS x 110 CTS)		E2609SG
REV	ECR	DESCRIPTION	DATE	BY	CHKR						

PART NUMBER
E2609SG
 JJ-MRKTG