

Installation

S59-3200

Thermostatic Mixing Valve (HL200)
with Optional Cabinet

S59-3200RE (with Recess-Mounted
Enamel Cabinet)

S59-3200RS (with Recess-Mounted
Stainless Steel Cabinet)

S59-3200SE (with Surface-Mounted
Enamel Cabinet)

S59-3200SS (with Surface-Mounted
Stainless Steel Cabinet)

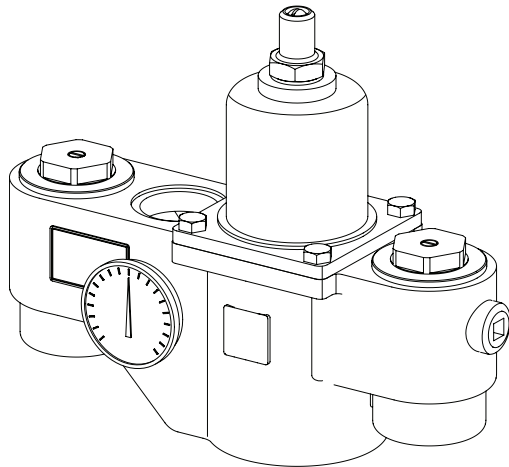

(Valve Only)

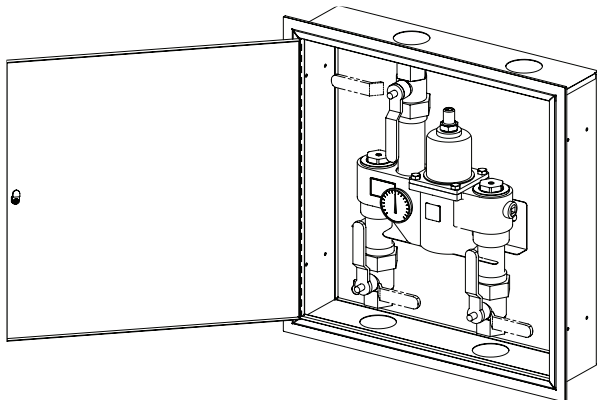

Inlet Connections: 2" NPT
Outlet Connection: 2" NPT
Temperature Range: 90–120°F
Maximum Pressure: 125 PSIG
Inlet Temperature Hot: 120–180°F
Inlet Temperature Cold: 33–80°F
Minimum Temperature Differential
(between hot supply & valve set point): 20°F

215-1299 Rev. P: ECO 20-09-011
© 2020 Bradley
Page 1 of 9 8/25/2020

Table of Contents

Safety Information	2
Supplies Recommended for Installation	3
Tools Required for Temperature Adjustment	3
Install Optional Cabinet	3
Optional Recessed / Surface Mount Cabinet Dimensions	4
Connect Supply Lines and Install Thermometer	5
Adjust Temperature with Water Running	5
Test Unit	5
Optional Water Recirculation Setup	6
Troubleshooting: Thermostatic Mixing Valve	7
Troubleshooting: Piston Disassembly and Cleaning	8
Parts Breakdown	9



Read the instructions in this manual before beginning installation. Save these instructions and refer to them for inspection, maintenance and troubleshooting information.

For questions regarding the operation, installation or maintenance of this product, visit bradleycorp.com or call 800.BRADLEY (800.272.3539).

Product warranties and parts information may also be found under "Resources" on our website at bradleycorp.com.

P.O. Box 309
Menomonee Falls, WI 53052 USA
800 BRADLEY (800 272 3539)
+1 262 251 6000
bradleycorp.com



Safety Information

To ensure proper operation:

Installation

Failure to comply with proper installation and maintenance instructions could contribute to a valve failure resulting in severe bodily injury including scalding, chilling and/or death depending upon system water pressure changes and/or supply water temperature changes.

Use this thermostatic mixing valve in accordance with ASSE standard 1017.

When installed in accordance with ASSE standard 1017, the valve is designed to be installed at or near the boiler or water heater. When installed as an ASSE 1017 valve, the valve does not function as an ASSE 1016, ASSE 1069 or ASSE 1070 valve.

This valve should not be used where ASSE standard 1016 devices are required.

This valve does not provide protection from pipe freezing.

Installation of this system must be completed by a qualified plumber in compliance with all national and local codes. Compliance and conformity to local codes and ordinances is the responsibility of the installer. Should these codes differ from the information in the manual, follow the local codes. Inquire with governing authorities for additional local requirements.

Inspection

Regular checking and cleaning of the valve's internal components and check stops is necessary for maximum life and proper product function. Periodic inspection and yearly maintenance by a licensed contractor is required. Corrosive water conditions and/or unauthorized adjustments or repairs could render the valve ineffective for its intended service. Frequency of cleaning and inspection depends upon local water conditions.

Output temperature of the valve must be checked and adjusted at initial installation and on a quarterly basis.

Water Temperature

Final temperature adjustment is the responsibility of the installer.

Supplies Recommended for Installation

- Lockable shut-off on the outlet if tempered water is supplied to one or more remote fixtures
- Lockable shut-off on the inlets/supplies
- (6) 3/8" wall anchors and fasteners for surface-mounted cabinet
- (4) 1/4" and (2) 3/8" fasteners (and wall anchors, if necessary) for recess-mounted cabinet
- Unions on all connections to facilitate removal of valve

Tools Required for Temperature Adjustment

- 5/32" Allen wrench
- Blade screwdriver

1 Install Optional Cabinet (If not installing cabinet, skip to Step 2)

Recessed Cabinet:

1. Rough-in wall opening 28-1/2" W x 28-1/2" H.
2. Insert the cabinet and secure to wall with four 1/4" fasteners properly anchored (supplied by installer.)
3. Install two 3/8" anchors and screws through the valve bracket in back of the cabinet into a secure brace (supplied by installer) or into wall. This will support the valve.
4. Install the valve nipples and one-half of the union ball valve using pipe sealant or teflon tape. Install the other half of the union ball valve onto inlet and outlet pipe.
5. Insert the valve into the bracket in the cabinet (right side goes in first). Continue with the valve installation procedure.
6. Position the wall flange tight to the wall and caulk in place.

Surface-Mounted Cabinet:

1. Measure and mark the cabinet mounting hole locations at the dimensions shown on next page. Install six 3/8" wall anchors (supplied by installer).
2. Position the cabinet onto the wall and secure into place with six 3/8" wall fasteners (supplied by installer).
3. Install the valve nipples and one-half of the union ball valve using pipe sealant or teflon tape. Then install the other half of the union ball valve onto the inlet and outlet piping.
4. Insert the valve into the bracket in the cabinet (right side of the valve goes in first). Continue with the valve installation procedure.

Optional Recessed / Surface Mount Cabinet Dimensions

(mm)

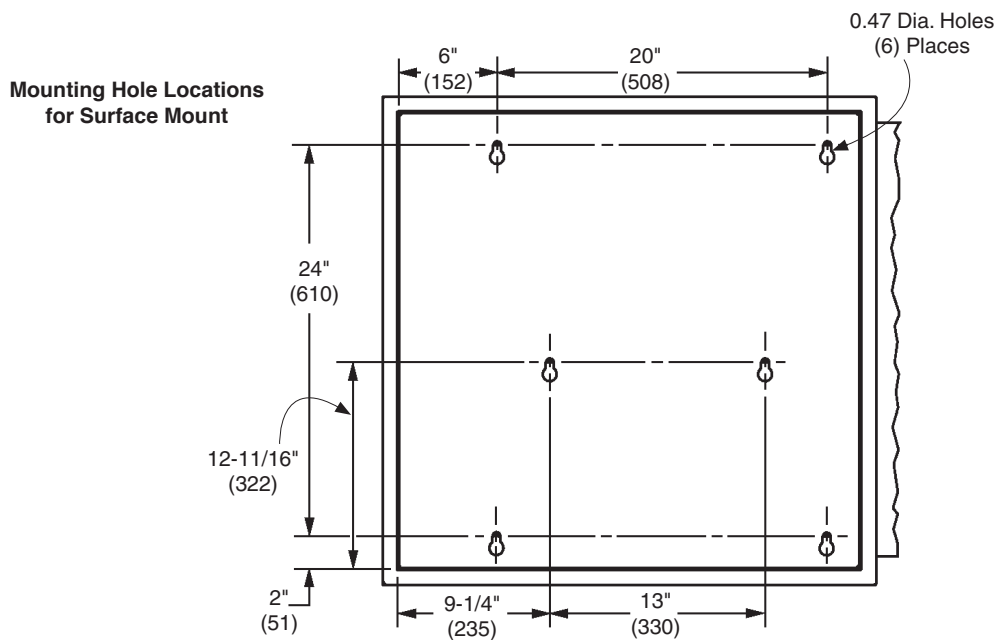
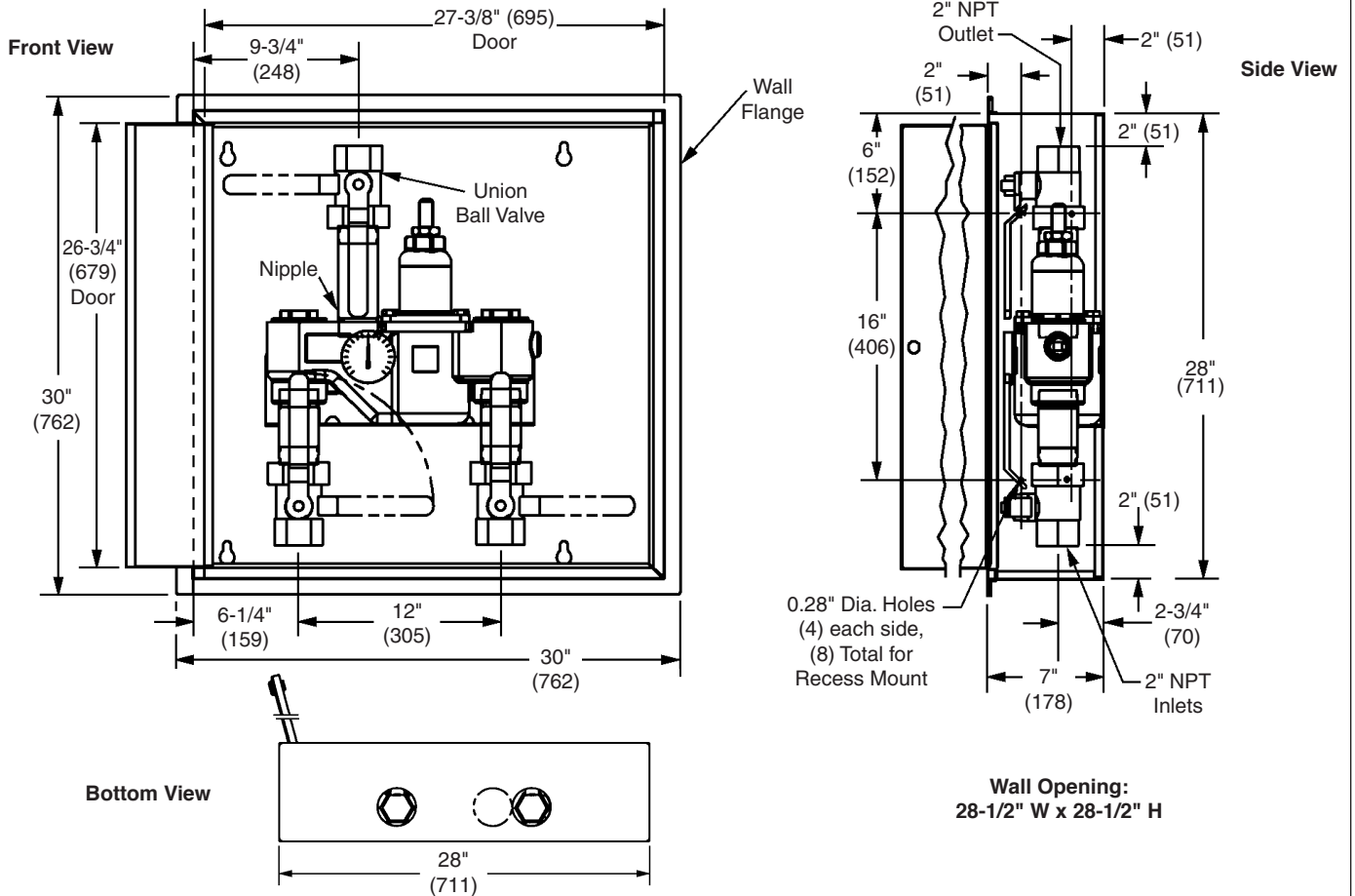

2 Connect Supply Lines and Install Thermometer

- ✓ *Flush the supply lines before beginning installation.*
- ✓ *When the check valves are in the open (operating) position, the cover screw for the stop/check stem will be flush with the valve cap.*
- ✓ *Install Optional Thermometer using pipe sealant or teflon tape.*
- ✓ *Check for leaks by pressurizing unit SLOWLY.*

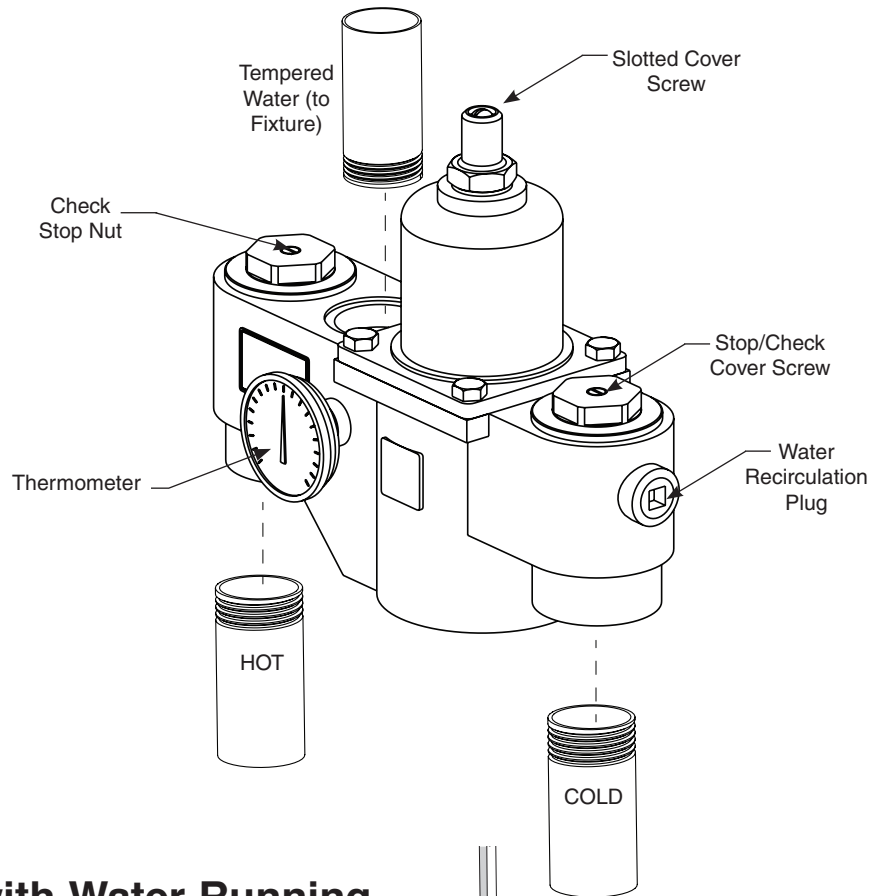

3 Adjust Temperature with Water Running

- ✓ *Check the temperature when approximately 10 GPM water flow is reached (equivalent to four standard showers).*
- ✓ *This device must be checked for final temperature and adjusted as necessary. The standard preset factory temperature setting is 105°F (40°C). [the range of the valve is 90°F – 120°F (32°C – 49°C)]. Consult proper medical and/or safety authorities for the optimum temperature recommended for your particular application.*

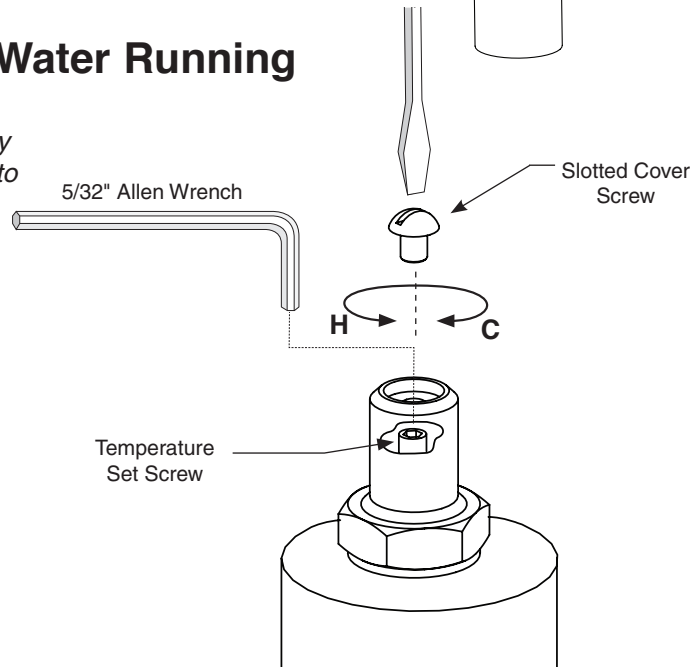

4 Test Unit **DO NOT SKIP THIS STEP!!!**

Shut the hot water supply off by closing hot water inlet valve or supply check valve. While the hot water supply is turned off, check to make sure the cold water is significantly reduced. If the cold water is reduced properly, reopen the hot water supply.

Shut the cold water supply off by closing the cold water inlet valve or supply check valve. While the cold water supply is off, check to make sure that the hot water flow has shut down. If hot water is shut down, reopen cold water supply. Test unit weekly for proper function and desired set temperature.

5 Optional Water Recirculation Setup



Recirculating the water in the system provides constant regulation of the water temperature. Flush the supply lines thoroughly after completing installation. Close off all fixtures and label them as not available for use during the recirculating process.

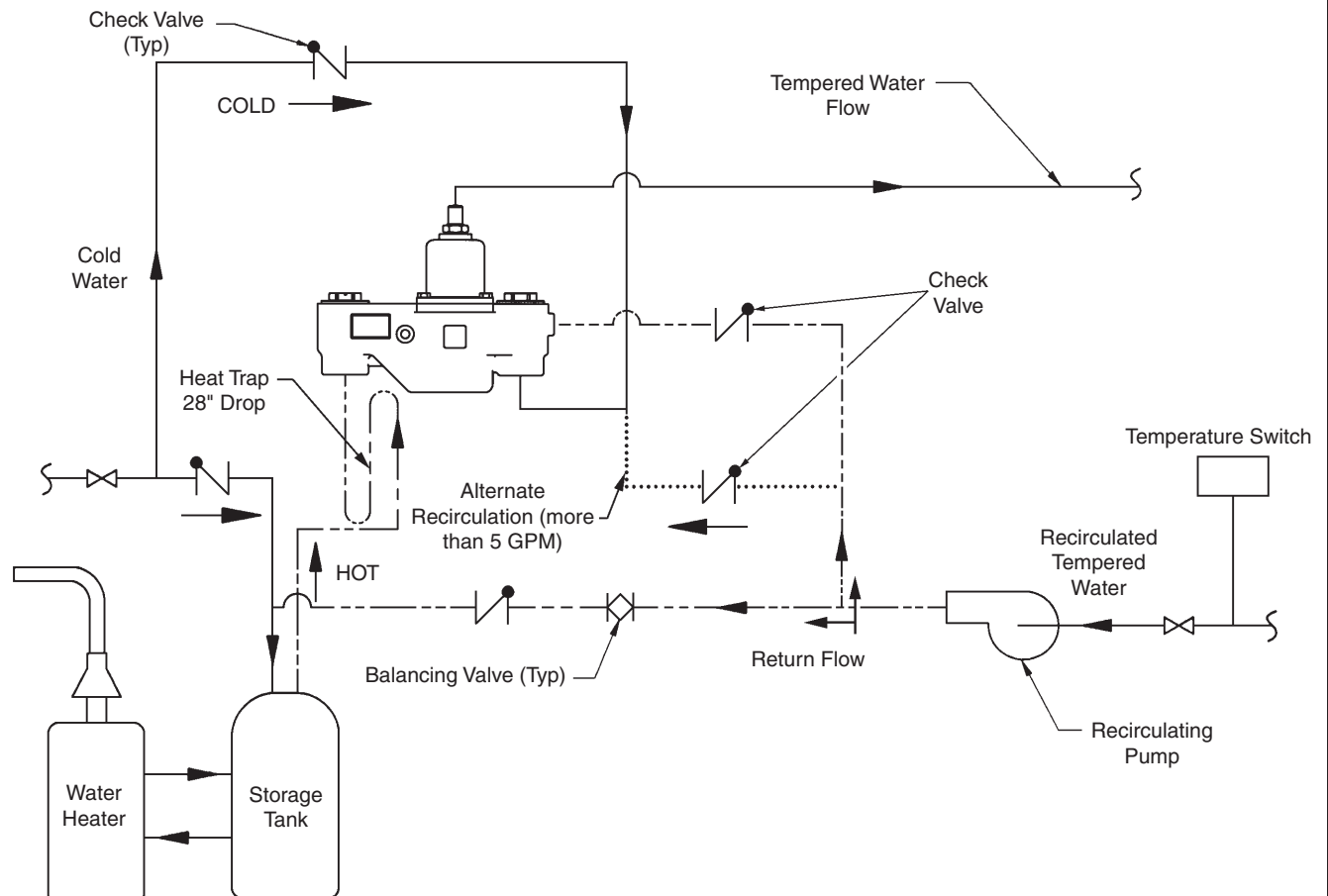

1. Turn off the recirculating pump and turn on the water supply (a water flow rate of 10-15 GPM is required).
2. Let the water run through the system until a consistent temperature is obtained. If you do not obtain the required temperature, refer to step #3 on previous page for temperature readjustment.
3. As soon as the water reaches the proper temperature, turn on the recirculating pump (make certain the proper system temperature has been achieved before proceeding).
4. Check the water temperature at the return pump. If the temperature exceeds the appropriate level by 2°F, adjust the temperature high-limit switch (this will turn off the pump). Wait until the return water temperature is 5°F below the appropriate level and adjust the low-limit switch (this will turn the pump back on).
5. Open the balancing valve completely.
6. Turn off all fixtures and make sure there is no water running through the system (the cold inlet pipe should feel warm to the touch).
7. Let the system run for 30 minutes or longer without water. If, after 30 minutes, the water temperature increases, you may readjust the temperature by slowly closing the balancing valve until the appropriate temperature is reached.

Troubleshooting: Thermostatic Mixing Valve

Before attempting to troubleshoot the valve or disassemble the components, check for the following:

- Stop/check valves are fully open (the slotted stem must be flush with the stop/check cap) and that all inlet and outlet shut-off valves are open
- Hot and cold inlet pipes are connected properly, and that there are no cross-connections or leaking stop/check valves
- Water heater output is at least 15° F above the set temperature.

Be sure to close the appropriate shut-off valves prior to disassembly of the valve and reopen the valves after inspection and repair is complete.

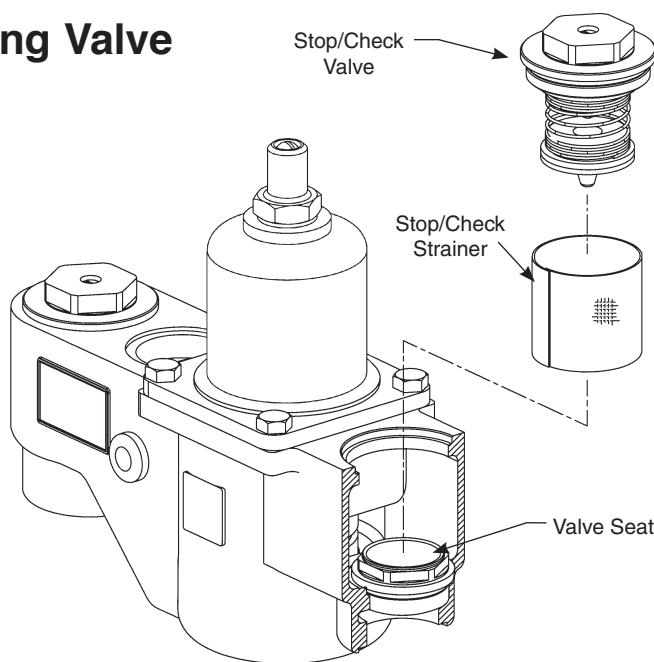

Valve appearance may differ slightly.

Problem	Cause	Solution
External leaks in the system	Either the NPT joints or the o-rings have been damaged.	Replace the NPT joints and/or o-rings where necessary. For replacement of o-rings, contact your Bradley representative and ask for O-Ring Seal Kit (S65-195).
No hot water flow (cold water flow only)	The thermostat has failed and, subsequently, the safety shut-off has engaged.	Inspect Thermostat: 1. Remove the top cap and pull out the push rod and thermostat. 2. Insert a 7/16" dia. rod into the thermostat bellows. 3. Mark the length of the thermostat bellows (at room temperature, with 10 lb. of force, the bellows length should be approx. 2-25/32" to 3-1/4"). 4. If the thermostat bellows length is not in the proper range, the thermostat must be replaced (it cannot be repaired). Contact your Bradley representative and ask for Thermostat Kit (S65-194).
Limited water flow	The inlet shut-off valve may be partially closed or there has been a significant decrease in water pressure.	
	Dirt and debris have collected on the check screen or seat, limiting the movement of the stop and checks.	Clean Stop and Check Valves: Remove the stop and checks, clean the screen and seat and reassemble the valve. Do not remove the seat. The components may be scraped with a screwdriver to remove debris. A pair of tweezers works well for pulling debris out from the seat. If the stop and checks need to be replaced, contact your Bradley representative and ask for Check/Stop Kit (S65-190).
Temperature fluctuation or improper Temperature	The stop and check sections of the valve do not move freely.	Clean Stop and Check Valves as described above.
	Thermostat is slowly failing.	Check Thermostat as described above, or replace.
	Inlet supply line to the mixing valve is being shared by other pieces of equipment that are used only periodically, such as laundry appliances or washdown stations. It may reduce the inlet pressure to the mixing valve to less than 10 PSI. The supply line size may not be large enough to supply both the valve and the other appliances.	Enlarge the supply line size, reconfigure the supply line or regulate the supply usage.
	Recirculation is not balanced.	Review recirculation set up on page 5.
	Piston does not move freely and must be cleaned.	See next page for piston disassembly and cleaning directions.

Troubleshooting: Piston Disassembly and Cleaning

WARNING! To prevent injuries, use proper protective equipment for eyes and skin when using a propane torch.

A Remove the valve's top cap and pull out the thermostat and push rod. You may use a needle-nose pliers to remove the thermostat from the valve body if desired.

B Insert a 7/16" dia. rod into the valve and into the piston overhear chamber. Mark the length of the rod inside the valve. Push the rod until the piston stops and mark the new length.

If the rod travels less than 9/16", the piston is not moving freely within the liner and they must be cleaned:

- C**
1. Remove the control section assembly, top cap and thermostat.
 2. Unthread the liner from the cap (it is glued together; the o-rings must be removed and heat should be applied to melt the glue and loosen the liner).
 3. Clean the piston and liner with any cleaner suitable for brass and stainless steel (400-grit sandpaper may be used to polish and hone the piston and liner).

D Push the mechanism up and down several times to make sure the piston moves smoothly and consistently. If it is not consistent, repeat Procedure C until it moves freely, or replace. Contact your Bradley representative and ask for Piston/Liner Kit (part number S65-196).

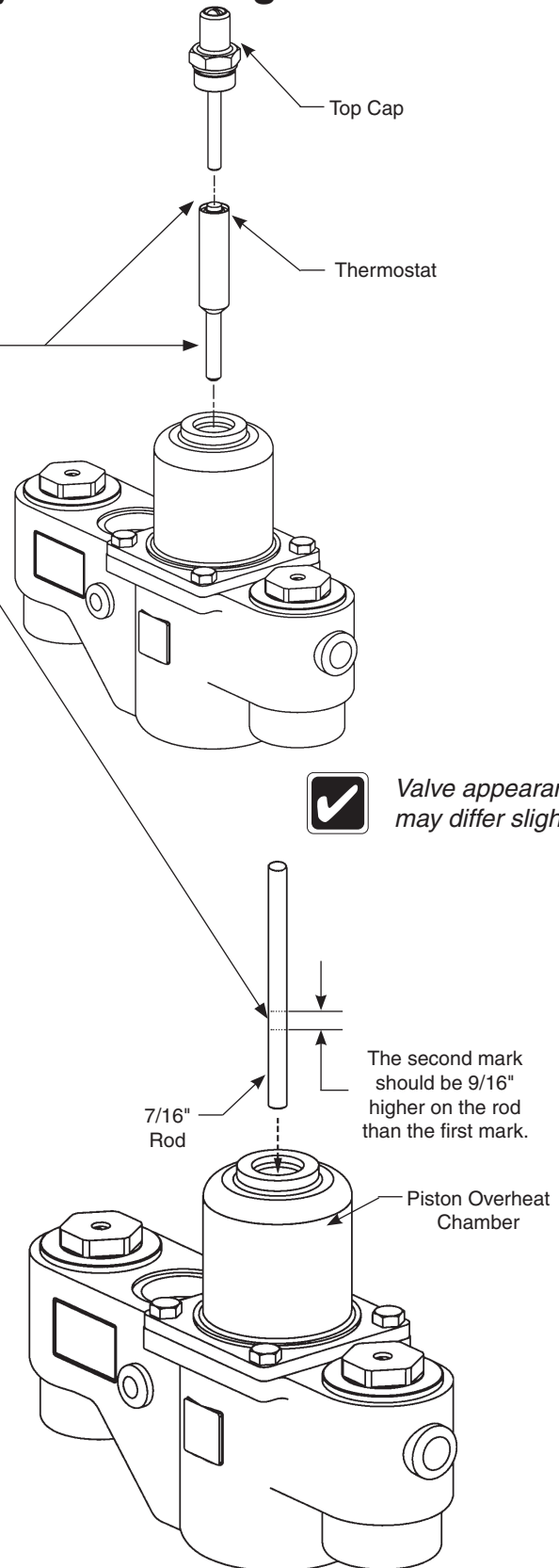

Parts Breakdown

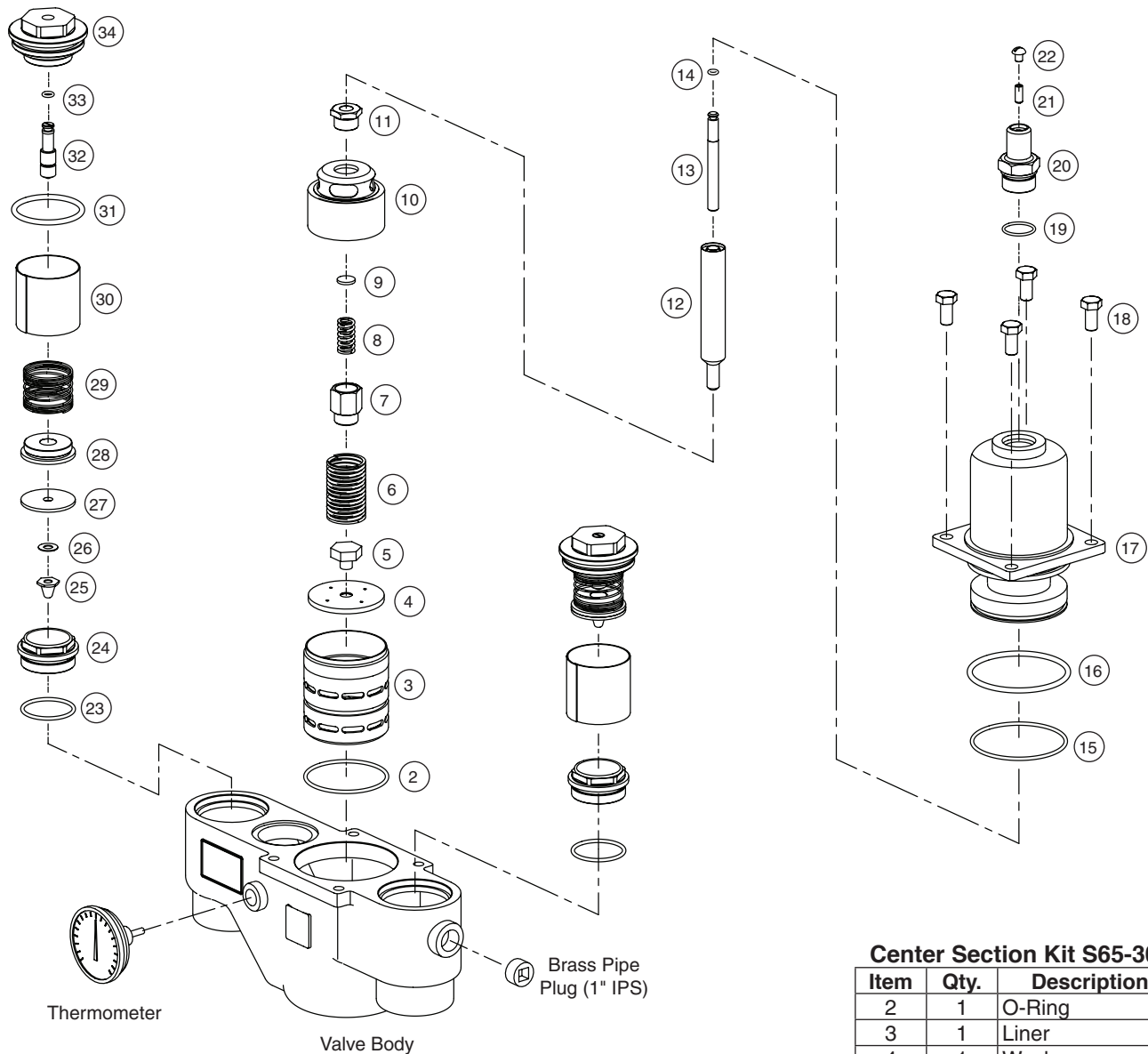

Center Section Kit S65-302

Item	Qty.	Description
2	1	O-Ring
3	1	Liner
4	1	Washer
5	1	Screw
6	1	Spring
7	1	Lower Overheat Chamber
8	1	Spring
9	1	Washer
10	1	Piston
11	1	Upper Overheat Chamber
12	1	Thermostat
13	1	Pushrod
14	1	O-Ring
15	1	O-Ring
16	1	O-Ring
17	1	Control Cap
18	4	Bolt
19	1	O-Ring
20	1	Top Cap
21	1	Set Screw
22	1	Screw

Thermostat Kit S65-194

Item	Qty.	Description
12	1	Thermostat
14	1	O-Ring
19	1	O-Ring

Washer/Seal Kit S65-321

Item	Qty.	Description
4	1	Washer
9	1	Washer
26	2	Washer
27	2	Seal

O-Ring Kit S65-195

Item	Qty.	Description
2	1	O-Ring
14	1	O-Ring
15	1	O-Ring
16	1	O-Ring
19	1	O-Ring
23	2	O-Ring
31	2	O-Ring
33	2	O-Ring

Check/Stop Kit S65-190

Item	Qty.	Description
23	2	O-Ring
24	2	Seat
25	2	Nut
26	2	Washer
27	2	Seal
28	2	Holder (for Seal)
29	2	Spring
30	2	Strainer
31	2	O-Ring
32	2	Stem
33	2	O-Ring
34	2	Cap

Piston & Liner Kit S65-196

Item	Qty.	Description
2	1	O-Ring
3	1	Liner
4	1	Washer
5	1	Screw
6	1	Spring
7	1	Lower Chamber
8	1	Spring
9	1	Washer
10	1	Piston
11	1	Upper Chamber