

REZNOR[®]

**UNIT HEATER
CATALOG**

Form RZ-NA-C-UH (Version F)

BACKGROUND

Reznor was founded in 1888 to manufacture the “Reznor” reflector heater, which used a luminous flame gas burner developed by George Reznor. This technological breakthrough was an immediate success and hastened the expansion of gas heating in residential and commercial applications. Technological development and innovation have been the hallmark of Reznor products through the years. The development of the forced air gas unit heater, the modular Thermocore® heat exchanger, and the high-efficiency, V3® Series unit heaters have kept Reznor products at the forefront of technological advances in commercial and industrial gas heating. As a result of this pioneering role in the heating, makeup air, and ventilating equipment field, the products offered today are the most advanced in engineering design to satisfy a wide variety of applications.

FACILITIES

Reznor heaters were first manufactured and sold in Mercer, Pennsylvania (70 miles north of Pittsburgh) in 1888. Over the years, the company has grown and expanded. Today, with sales worldwide, Reznor products are being manufactured at facilities throughout North America and Europe.

PRODUCT SCOPE

Well-equipped engineering laboratories for both product development and testing can be found at many of the manufacturing sites. All domestic lab sites are agency approved.

Reznor Products include a complete line of heating, makeup air and ventilating systems, using gas, oil, hot water/steam, or electric heat sources. Reznor heater catalogs are designed to aid the engineer, architect or contractor in specifying the correct equipment for all standard and special applications. Complete data is presented on unit heaters, duct furnaces, infrared heaters, makeup air systems, pre-engineered custom-designed systems, and evaporative cooling modules. Consult your local Reznor Sales Representative for further assistance in specifying Reznor Equipment for your specific application.

SERVICES

Product service requirements are handled through contractors and/or distributors, with backup from local representatives and factory-based service team. Replacement parts inventories for both warranty and non-warranty requirements are maintained at service centers throughout the country and at the manufacturing facilities.

See back cover for the Reznor Representative in your area. Or call 800-695-1901.

REZNOR®

Thomas&Betts

UNIT HEATERS

Table of Contents

	Model	Description	Page
GAS-FIRED	UDAS	Gas fired, up to 83% efficient, separated combustion unit for commercial/industrial or residential use	2
	UDAP	Gas fired, up to 83% efficient, power-vented unit for commercial/industrial or residential use	6
	UDBS	Gas fired, up to 83% efficient, separated combustion, high static unit for commercial/industrial use	10
	UDBP	Gas fired, up to 83% efficient, power-vented, high static unit for commercial/industrial use	14
	SHE	Gas fired, 93% efficient, separated combustion, condensing unit heater	18
	F	Gravity-vented, propeller fan-type	20
	B	Gravity-vented, centrifugal blower-type	22
	OH	Gravity-vented, propeller fan-type	24
	OB	Gravity-vented, centrifugal blower-type	24
	OIL-FIRED		Throw and Floor Coverage
		Sound Data	31
		Blower Charts for Model UDBP & UDBS	32
		Blower Curves and Charts for Model B with Drive Motor	36
		Blower Motor FLA Table	40
		Installation	41
		Warnings and General	41
		Venting - Optional Power Venting of Models F and B	41
		Venting - Separated-Combustion	42
		Pilot, Gas Controls, and Air Controls - Gas-Fired Units	44
OPTIONS AND ACCESSORIES		Optional Accessories	44
		Stepdown Transformers	44
		Polytube Adapter	45
		Downturn Nozzles	47
		Oil Fuel Tank - Model OT250	47
SAMPLE SPECIFICATIONS			48
WARRANTY			53
ELECTRIC UNIT HEATERS		See Electric Heating Catalog	
HYDRONIC UNIT HEATERS		See the Hydronic Unit Heater Catalog	

IMPORTANT: Specifications are subject to change without notice. This guide is intended to provide specifications and technical information only.

This guide is not intended to be an instruction manual. When installing heating and ventilating equipment, you must check and conform to all local and national building codes. Improper installation of heating and ventilating equipment could be dangerous. Consult manufacturer's installation manual for instructions and important warnings.

REZNOR®

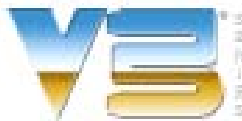

CSA 2.6b



ANSI Z83.8b

DESCRIPTION

Reznor® V3 Series Model UDAS gas-fired separated combustion unit heaters are available in 14 sizes ranging from 30,000 to 400,000 BTUH gas input. Sizes 30-125 are approved for residential application. All sizes are approved for commercial/industrial installations. Model UDAS heaters are designed for 82-83% thermal efficiency and are approved for installation in the United States and Canada by the Canadian Standards Association (CSA).

Reznor® V3 Series unit heaters have a refreshing new appearance with a glossy white cabinet finish and less visible hardware. Each size cabinet is easily suspended from either 2 or 4 suspension points. Or, an optional hanger kit for Sizes 30-125 allows for ceiling mounting. The low voltage terminal strip on the outside of the cabinet makes connecting control wiring easy with no panels to remove. The addition of a "G" terminal to the low voltage strip, along with the new design of the circuit board, allows for fan only operation (without adding relays). All units have a factory installed gas line nipple to the exterior of the cabinet for easy gas service connection.

The preeminent new internal feature is the T_{CORE}² heat exchanger and single burner combustion system. Other standard features include a single-stage gas valve, multi-try direct spark ignition with 100% lockout, pressure switch to verify vent flow, resiliently isolated venter motor, venter wheel with improved housing, resiliently isolated axial fan and motor assembly, a high temperature limit control, interlock door switch, and a built-in disconnect switch. Sizes 30-125 also include a flame rollout safety switch. Operation is controlled through an integrated circuit board. The circuit board monitors heater operation and has LED diagnostic indicator lights to identify abnormalities in control functions.

The 1ST ever separated combustion system in the commercial/industrial heating industry was introduced on a Reznor heater in the 1960's, and that proven technology is continued in this new separated combustion product. Model UDAS separated combustion units require installation of a specially designed combustion air/vent system including the unique concentric adapter box that allows for only one building penetration for both the vent and combustion air.

The new V3 Series unit heaters are designed to provide all the features you expect in a Reznor heater plus improved efficiency, easier installation, and a new look ~ **both inside and out.**

Form RZ-NA-C-UH Page 2

Model UDAS

Separated Combustion, Low Static Unit Heaters for Residential and Commercial/Industrial Use

Sizes 30-125
approved for utility applications
such as residential garages
under CSA International Requirement 10.96 U.S.

STANDARD FEATURES

- Sizes 30-125 certified for residential heating application
- Sizes 30-400 certified for commercial/industrial heating application
- 82-83% Thermal efficient ~ **TOP in its class!**
- 50-60°F Rise range
- **NEW** T_{CORE}² titanium stabilized aluminized steel heat exchanger
- **NEW** patented** T_{CORE}² single burner combustion system including a one-piece burner assembly
- 115/1/60 Supply voltage
- 115 Volt open fan motor with internal overload protection
- Transformer for 24-volt controls
- Integrated circuit board with diagnostic indicator lights
- Multi-try direct ignition with 100% lockout
- Fan relay (included on the circuit board)
- Single-stage natural gas valve (field adjustable for operation to 9,000 ft elevation)
- Vibration/noise isolated fan and venter motors
- Sealed control compartment houses all electrical components
- 2-pt **and** 4-pt Suspension ~ **standard on all sizes**
- Built-in disconnect switch (20A @ 115V Rating)
- External terminal strip for 24-volt wiring
- Sealed junction box for supply wiring
- External gas connection
- Fully gasketed door panel with safety door switch
- Full fan guard ~ **engineered for safety**
- Improved cabinet design with less visible hardware and a **NEW** Reznor appearance

OPTIONAL FEATURES - FACTORY INSTALLED

- Single-stage, propane gas valve (field adjustable for operation to 9,000 ft elevation)
- Two-stage natural gas or propane gas valve - Sizes 60-400
- 409 or 316 Stainless steel heat exchangers
- 208 or 230 Single phase voltage
- Totally enclosed fan motor (Sizes 30-250, 115V only)

ACCESSORIES - FIELD INSTALLED

- *Horizontal or Vertical Combustion Air/Vent Kit including concentric adapter
- Thermostat
- Thermostat guard with locking cover
- Vertical louvers ~ **new design**
- Downturn nozzle kits ~ **new design**
- Gas conversion kits (natural and propane)
- Master/Slave controls for zoning up to six units
- Ceiling suspension kit - Sizes 30-125
- Hanger kits for 1" pipe
- Stepdown transformer (for 230/3 & 460/3 voltage)
- Manual shutoff valves

* Selection of either a horizontal or vertical combustion air/vent kit is **required.**

** U.S. Patent No. 6,889,686

MODEL UDAS TECHNICAL DATA - Sizes 30 - 125

Size		30	45	60	75	100	125
Input Heating Capacity	BTUH	30,000	45,000	60,000	75,000	105,000	120,000
	kw/h	8.8	13.2	17.6	22.0	30.8	35.2
Thermal Efficiency (%)		82	83	83	83	83	83
Output Heating Capacity ^A	BTUH	24,600	37,350	49,800	62,250	87,150	99,600
	kw/h	7.2	11.0	14.6	18.3	25.6	29.2
Gas Connection (inches) ^B	Natural	1/2	1/2	1/2	1/2	1/2	1/2
	Propane	1/2	1/2	1/2	1/2	1/2	1/2
Vent Connection ^C (inches diameter)		4	4	4	4	4	4
Combustion Air Inlet ^C (inches diameter)		4	4	4	4	4	4
Control Amps (24 volt)		1.0	1.0	1.0	1.0	1.0	1.0
Full Load Amps (115 volt)		1.9	2.4	2.4	3.3	3.9	5.1
Maximum Over Current Protection (115V) ^D		15	15	15	15	15	15
Normal Power Consumption (watts)		109	155	155	217	276	354
Discharge Air Temperature Rise (°F)		50	55	60	60	60	60
Air Volume	CFM	456	629	769	961	1345	1537
	M ³ /minute	12.9	17.8	21.8	27.5	36.7	45.9
Discharge Air Opening Area	ft ²	0.96	0.96	1.25	1.25	2.01	2.01
	M ²	0.09	0.09	0.12	0.12	0.19	0.19
Output Velocity	FPM	475	656	616	770	668	763
	M/minute	145	200	188	238	196	245
Fan Motor HP ^E	Open	0.02	0.03	0.03	0.06	1/30	1/20
	Enclosed	N.A.	N.A.	N.A.	N.A.	1/4	1/4
Fan Motor	RPM	1550	1550	1550	1550	1050	1050
Fan Diameter	inches	10	10	12	12	16	16
Sound Level	dba @ 15 ft	40	40	40	49	54	55
Approximate Net Weight	lbs	55	60	68	73	97	102
	kg	25	27	31	33	44	46
Approximate Ship Weight	lbs	63	68	76	81	120	125
	kg	29	31	34	37	54	57

^ACSA rating for altitudes to 2000 ft.^BSize shown is for gas connection to a single stage gas valve, not supply line size.^CSmaller and/or larger vent and combustion air pipe diameters may be allowed; refer to the Venting Installation Manual for Separated Combustion Units, Form I-V-SC. If vent diameter is different from vent connection, reducer/enlargers will be field-required.^DMODP = 2.25 x (largest motor FLA) + smallest motor FLA. Answer is rounded to the nearest commercially available circuit breaker. ^EAll other information in this table is based on a heater equipped with a standard 115 volt open fan motor.**MODEL UDAS TECHNICAL DATA Sizes 150 - 400**

Size		150	175	200	225	250	300	350	400
Input Heating Capacity	BTUH	150,000	175,000	200,000	225,000	250,000	300,000	350,000	400,000
	kw/h	43.9	51.2	58.6	65.9	73.2	87.8	102.5	117.1
Thermal Efficiency (%)		83	83	83	83	83	83	83	83
Output Heating Capacity ^A	BTUH	124,500	145,250	166,000	186,750	207,500	249,000	290,500	332,000
	kw/h	36.4	42.5	48.6	54.7	60.8	72.9	85.1	97.2
Gas Connection (inches) ^B	Natural	1/2	1/2	1/2	3/4	3/4	3/4	3/4	3/4
	Propane	1/2	1/2	1/2	3/4	3/4	3/4	3/4	3/4
Vent Connection ^C (inches diameter)		5	5	5	5	5	6	6	6
Combustion Air Inlet ^C (inches diameter)		6	6	6	6	6	6	6	6
Control Amps (24 volt)		1.0	1.0	1.0	1.0	1.0	1.0	1.0	1.0
Full Load Amps (115 volt)		3.8	3.8	4.6	7.5	7.5	11.0	11.0	11.0
Maximum Over Current Protection (115V) ^D		15	15	15	15	15	20	20	20
Normal Power Consumption (watts)		392	392	491	747	747	1086	1086	1086
Discharge Air Temperature Rise (°F)		60	60	60	60	60	60	60	60
Air Volume	CFM	1921	2242	2562	2882	3202	3843	4483	5123
	M ³ /minute	54.4	63.5	72.5	81.6	90.7	108.8	126.9	145.1
Discharge Air Opening Area	ft ²	2.56	2.56	2.56	3.51	3.51	4.79	4.79	4.79
	M ²	0.24	0.24	0.24	0.33	0.33	0.45	0.45	0.45
Output Velocity	FPM	752	877	1003	820	911	802	936	1069
	M/minute	229	267	306	250	278	244	285	326
Fan Motor HP ^E	Open	1/6	1/6	1/6	1/4	1/4	1/2	1/2	1/2
	Enclosed	1/4	1/4	1/4	1/4	1/4	1/2	1/2	1/2
Fan Motor	RPM	1050	1050	1050	1050	1050	1050	1050	1050
Fan Diameter	inches	18	18	18	20	20	24	24	24
Sound Level	dba @ 15 ft	51	52	53	56	56	59	61	62
Approximate Net Weight	lbs	173	188	188	204	216	270	295	307
	kg	78	85	85	93	98	122	134	139
Approximate Ship Weight	lbs	206	221	221	247	259	323	348	360
	kg	93	100	100	112	117	147	158	163

Model UDAS - GENERAL ARRANGEMENT AND DIMENSIONS

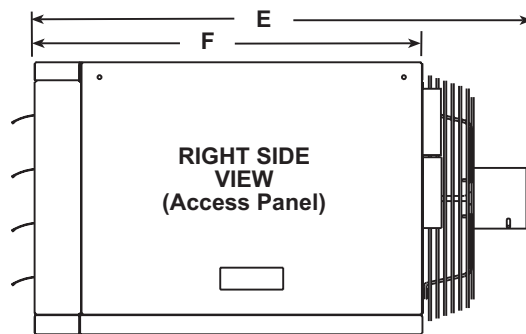
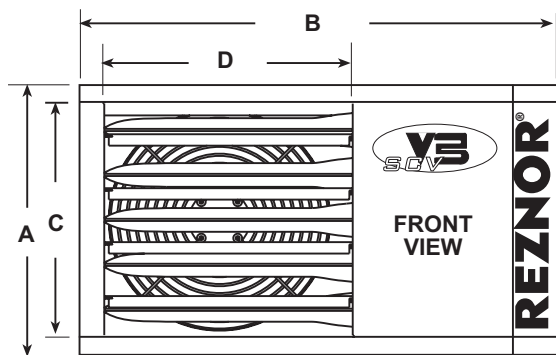
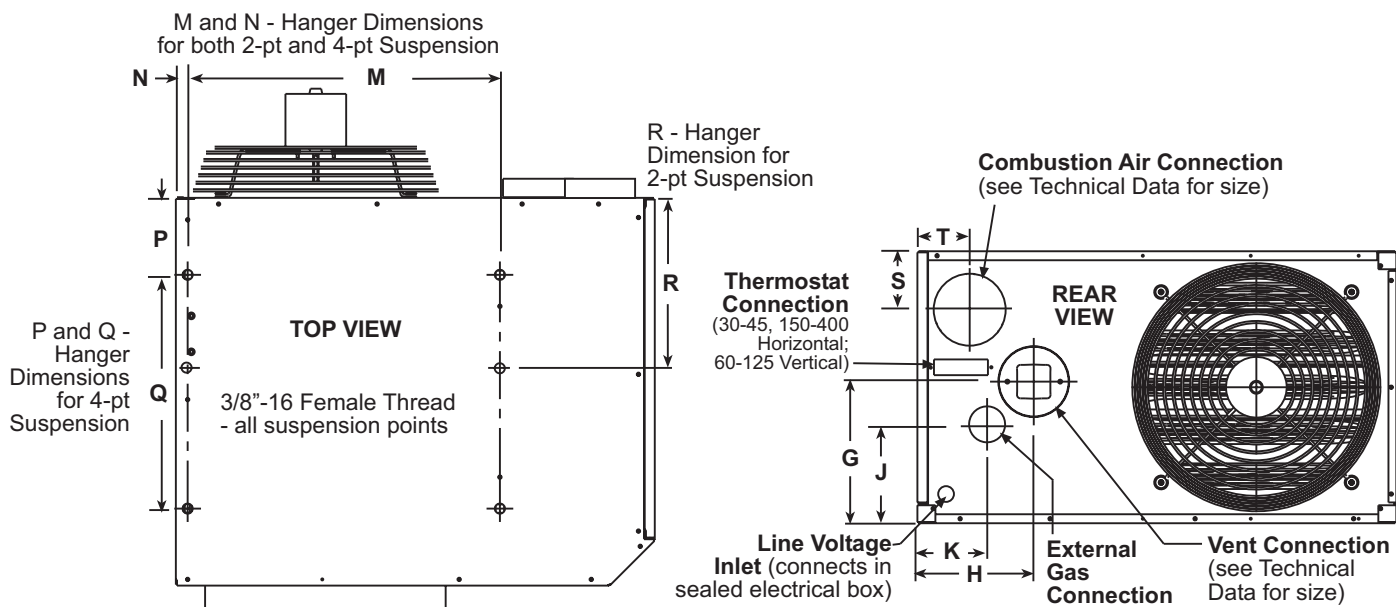

MODEL UDAS DIMENSIONS (± 1/16")

Size	A	B	C	D	E	F	G	H	J	K	M	N	P	Q	R	S	T
30, 45	12-1/8	26-5/8	10	13-13/16	26	21-9/16	5-3/16	6-1/2	2-11/16	3-7/8	17-3/8	11/16	4-5/16	13	9-9/16	2-15/16	2-15/16
60	15-1/8	26-5/8	13	13-13/16	27	21-9/16	7-7/8	6-1/2	5-1/2	3-7/8	17-3/8	11/16	4-5/16	13	10-1/2	3-1/4	2-15/16
75	15-1/8	26-5/8	13	13-13/16	27-5/8	21-9/16	7-7/8	6-1/2	5-1/2	3-7/8	17-3/8	11/16	4-5/16	13	10-1/2	3-1/4	2-15/16
100	23-1/8	26-5/8	21	13-13/16	28-5/8	21-9/16	14-1/2	6-1/2	8-3/4	3-7/8	17-3/8	11/16	4-5/16	13	10-1/2	4-5/8	2-15/16
125	23-1/8	26-5/8	21	13-13/16	29-3/8	21-9/16	14-1/2	6-1/2	8-3/4	3-7/8	17-3/8	11/16	4-5/16	13	10-1/2	4-5/8	2-15/16
150, 175, 200	20-1/8	38-3/16	16	23	42	35-3/8	8-1/2	8-1/4	5-7/16	6-1/2	25-11/16	1-3/8	8-3/16	22-3/16	16-3/8	4-1/8	8-5/16
225, 250	26-1/8	38-3/16	22	23	42	35-3/8	13-1/16	8-13/16	9	6-1/2	25-11/16	1-3/8	8-3/16	22-3/16	15-5/8	5-9/16	8-5/16
300, 350, 400	34-1/8	41	30	23	42	35-3/8	17-1/16	9	11-13/16	7-5/16	27-11/16	1-3/8	8-3/16	22-3/16	16-3/16	9-1/16	8-9/16

For Metric Dimensions, see next page.

Model UDAS - GENERAL ARRANGEMENT AND DIMENSIONS (cont'd)**MODEL UDAS DIMENSIONS (± 2mm)**

Size	A	B	C	D	E	F	G	H	J	K	M	N	P	Q	R	S	T
30, 45	308	676	254	351	660	548	132	165	68	98	441	17	110	330	243	75	75
60	384	676	330	351	686	548	200	165	140	98	441	17	110	330	267	89	75
75	384	676	330	351	702	548	200	165	140	98	441	17	110	330	267	89	75
100	587	676	533	351	727	548	368	165	222	98	441	17	110	330	267	117	75
125	587	676	533	351	746	548	368	165	222	98	441	17	110	330	267	117	75
150, 175, 200	511	970	406	584	1067	899	216	210	138	165	652	35	208	564	416	105	211
225, 250	664	970	559	584	1067	899	332	224	229	165	652	35	208	564	397	141	211
300, 350, 400	867	1041	762	584	1067	899	433	229	300	186	703	35	208	564	411	230	217

CLEARANCES

Size	Top		Flue Connector		Access Panel		Non-Access Side		Bottom*		Rear	
	inches	mm	inches	mm	inches	mm	inches	mm	inches	mm	inches	mm
30-125	1	25	6	152	18	457	1	25	1	25	18	457
150-400	4	102	6	152	18	457	2	51	1	25	18	457

*Suspend the heater so that the bottom is a minimum of 5' (1.5M) above the floor.

**Refer to page 42 & 43 for venting/inlet air
requirements for
Reznor Separated Combustion Units**

REZNOR®

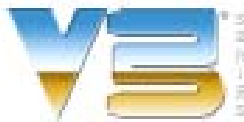

CSA 2.6b



ANSI Z83.8b



Model UDAP

Power Vented, Low Static Axial Fan Unit Heaters for Residential and Commercial/Industrial Use

Sizes 30-125

approved for utility applications

such as residential garages

under CSA International Requirement 10.96 U.S.

STANDARD FEATURES

- Sizes 30-125 certified for residential heating application
- Sizes 30-400 certified for commercial/industrial heating application
- 82-83% Thermal efficient ~ **TOP in its class!**
- 50-60°F Rise range
- **NEW** T_{CORE}²® titanium stabilized aluminized steel heat exchanger
- **NEW** patented** T_{CORE}²® single burner combustion system including a one-piece burner assembly
- 115/1/60 Supply voltage
- 115 Volt open fan motor with internal overload protection
- Transformer for 24-volt controls
- Integrated circuit board with diagnostic indicator lights
- Multi-try direct spark ignition with 100% lockout
- Fan relay (included on the circuit board)
- Single-stage natural gas valve (field adjustable for operation to 9,000 ft elevation)
- Vibration/noise isolated fan and venter motors ~ **designed for low noise operation**
- 2-pt **and** 4-pt Suspension ~ **standard on all sizes**
- External terminal strip for 24-volt wiring
- External gas connection
- Full fan guard ~ **engineered for safety**
- Improved cabinet design with less visible hardware and a **NEW** Reznor appearance

DESCRIPTION

Reznor® V3 Series Model UDAP gas-fired unit heaters are available in 14 sizes ranging from 30,000 to 400,000 BTUH gas input. Sizes 30-125 are approved for residential application. All sizes are approved for commercial/industrial installations. Model UDAP heaters are designed for 82-83% thermal efficiency and are approved for installation in the United States and Canada by the Canadian Standards Association (CSA).

Reznor® V3 Series unit heaters have a refreshing new appearance with a glossy white cabinet finish and less visible hardware. Each size cabinet is easily suspended from either 2 or 4 suspension points. Or, an optional hanger kit for Sizes 30-125 allows for ceiling mounting. The low voltage terminal strip on the outside of the cabinet makes connecting control wiring easy with no panels to remove. The addition of a "G" terminal to the strip, along with the new design of the circuit board, allows for fan only operation (without adding relays). All units have a factory installed gas line nipple to the exterior of the cabinet for easy gas service connection.

The preeminent new internal feature is the T_{CORE}²® heat exchanger and single burner combustion system. Other standard features include a single-stage gas valve, multi-try direct spark ignition with 100% lockout, pressure switch to verify vent flow, resiliently isolated venter motor, venter wheel with improved housing, resiliently isolated axial fan and motor assembly, and a high temperature limit control. Sizes 30-125 also include a flame rollout safety switch. Operation is controlled through an integrated circuit board. The circuit board monitors heater operation and has LED diagnostic indicator lights to identify abnormalities in control functions.

The new V3 Series unit heaters are designed to provide all the features you expect in a Reznor heater plus improved efficiency, easier installation, and a new look ~ **both inside and out.**

Form RZ-NA-C-UH Page 6

OPTIONAL FEATURES - FACTORY INSTALLED

- Single-stage, propane gas valve (field adjustable for operation to 9,000 ft elevation)
- Two-stage natural gas or propane gas valve - Sizes 60-400
- 409 or 316 Stainless steel heat exchangers
- 208 or 230 Single phase voltage
- Totally enclosed fan motor (Sizes 30-250, 115V only)
- Common venting with other gravity vented Category I appliance(s) (Sizes 30-100)

ACCESSORIES - FIELD INSTALLED

- Vent cap
- Thermostat
- Thermostat guard with locking cover
- Vertical louvers ~ **new design**
- Downturn nozzle kits ~ **new design**
- Gas conversion kits (natural and propane)
- Master/Slave controls for zoning up to six units
- Ceiling suspension kit - Sizes 30-125
- Hanger kits for 1" pipe
- Stepdown transformer (for 230/3 and 460/3 supply voltage)
- Manual shutoff valves

** U.S. Patent No. 6,889,686

MODEL UDAP TECHNICAL DATA - Sizes 30 - 125

Size		30	45	60	75	100	125
Input Heating Capacity	BTUH	30,000	45,000	60,000	75,000	105,000	120,000
	kw/h	8.8	13.2	17.6	22.0	30.8	35.2
Thermal Efficiency (%)		82	83	83	83	83	83
Output Heating Capacity ^A	BTUH	24,600	37,350	49,800	62,250	87,150	99,600
	kw/h	7.2	11.0	14.6	18.3	25.6	29.2
Gas Connection (inches) ^B	Natural	1/2	1/2	1/2	1/2	1/2	1/2
	Propane	1/2	1/2	1/2	1/2	1/2	1/2
Vent Connection Size ^C (inches diameter)		4	4	4	4	4	4
Control Amps (24 volt)		1.0	1.0	1.0	1.0	1.0	1.0
Full Load Amps (115 volt)		1.9	2.4	2.4	3.3	3.9	5.1
Maximum Over Current Protection (115V) ^D		15	15	15	15	15	15
Normal Power Consumption (watts)		109	155	155	217	276	354
Discharge Air Temperature Rise (°F)		50	55	60	60	60	60
Air Volume	CFM	456	629	769	961	1345	1537
	M ³ /minute	12.9	17.8	21.8	27.5	36.7	45.9
Discharge Air Opening Area	ft ²	0.96	0.96	1.25	1.25	2.01	2.01
	M ²	0.09	0.09	0.12	0.12	0.19	0.19
Output Velocity	FPM	475	656	616	770	668	763
	M/minute	145	200	188	238	196	245
Fan Motor HP ^E	Open	0.02	0.03	0.03	0.06	1/30	1/20
	Enclosed	N.A.	N.A.	N.A.	N.A.	1/4	1/4
Fan Motor RPM		1550	1550	1550	1550	1050	1050
Fan Diameter (inches)		10	10	12	12	16	16
Sound Level	dba @ 15 ft	40	40	40	49	54	55
Approximate Net Weight	lbs	54	59	67	72	96	101
	kg	24	27	30	33	44	46
Approximate Ship Weight	lbs	61	66	74	79	118	123
	kg	27	30	33	36	54	56

^ACSA rating for altitudes to 2000 ft.

^BSize shown is for gas connection to a single stage gas valve, not supply line size.

^CSmaller or larger vent pipe diameters may be allowed; refer to the Venting Installation Manual, Form I-V-PV. If vent diameter is different from vent connection, reducer/enlargers will be field-required.

^DMODP = 2.25 x (largest motor FLA) + smallest motor FLA. Answer is rounded to the nearest commercially available circuit breaker. ^EAll other information in this table is based on a heater equipped with a standard 115 volt open fan motor.

MODEL UDAP TECHNICAL DATA Sizes 150 - 400

Size		150	175	200	225	250	300	350	400
Input Heating Capacity	BTUH	150,000	175,000	200,000	225,000	250,000	300,000	350,000	400,000
	kw/h	43.9	51.2	58.6	65.9	73.2	87.8	102.5	117.1
Thermal Efficiency (%)		83	83	83	83	83	83	83	83
Output Heating Capacity ^A	BTUH	124,500	145,250	166,000	186,750	207,500	249,000	290,500	332,000
	kw/h	36.4	42.5	48.6	54.7	60.8	72.9	85.1	97.2
Gas Connection (inches) ^B	Natural	1/2	1/2	1/2	3/4	3/4	3/4	3/4	3/4
	Propane	1/2	1/2	1/2	3/4	3/4	3/4	3/4	3/4
Vent Connection Size ^C (inches diameter)		5	5	5	5	5	6	6	6
Control Amps (24 volt)		1.0	1.0	1.0	1.0	1.0	1.0	1.0	1.0
Full Load Amps (115 volt)		3.8	3.8	4.6	7.5	7.5	11.0	11.0	11.0
Maximum Over Current Protection (115V) ^D		15	15	15	15	15	20	20	20
Normal Power Consumption (watts)		392	392	491	747	747	1086	1086	1086
Discharge Air Temperature Rise (°F)		60	60	60	60	60	60	60	60
Air Volume	CFM	1921	2242	2562	2882	3202	3843	4483	5123
	M ³ /minute	54.4	63.5	72.5	81.6	90.7	108.8	126.9	145.1
Discharge Air Opening Area	ft ²	2.56	2.56	2.56	3.51	3.51	4.79	4.79	4.79
	M ²	0.24	0.24	0.24	0.33	0.33	0.45	0.45	0.45
Output Velocity	FPM	752	877	1003	820	911	802	936	1069
	M/minute	229	267	306	250	278	244	285	326
Fan Motor HP ^E	Open	1/6	1/6	1/6	1/4	1/4	1/2	1/2	1/2
	Enclosed	1/4	1/4	1/4	1/4	1/4	1/2	1/2	1/2
Fan Motor RPM		1050	1050	1050	1050	1050	1050	1050	1050
Fan Diameter (inches)		18	18	18	20	20	24	24	24
Sound Level	dba @ 15 ft	51	52	53	56	56	59	61	62
Approximate Net Weight	lbs	172	187	187	203	215	269	294	306
	kg	78	85	85	92	98	122	133	139
Approximate Ship Weight	lbs	204	219	219	245	257	321	346	358
	kg	93	100	100	111	117	146	157	163

Model UDAP - GENERAL ARRANGEMENT AND DIMENSIONS

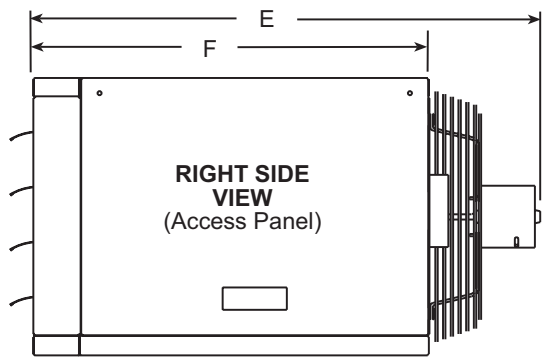
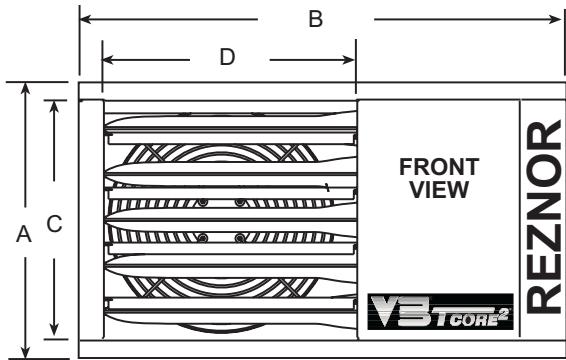
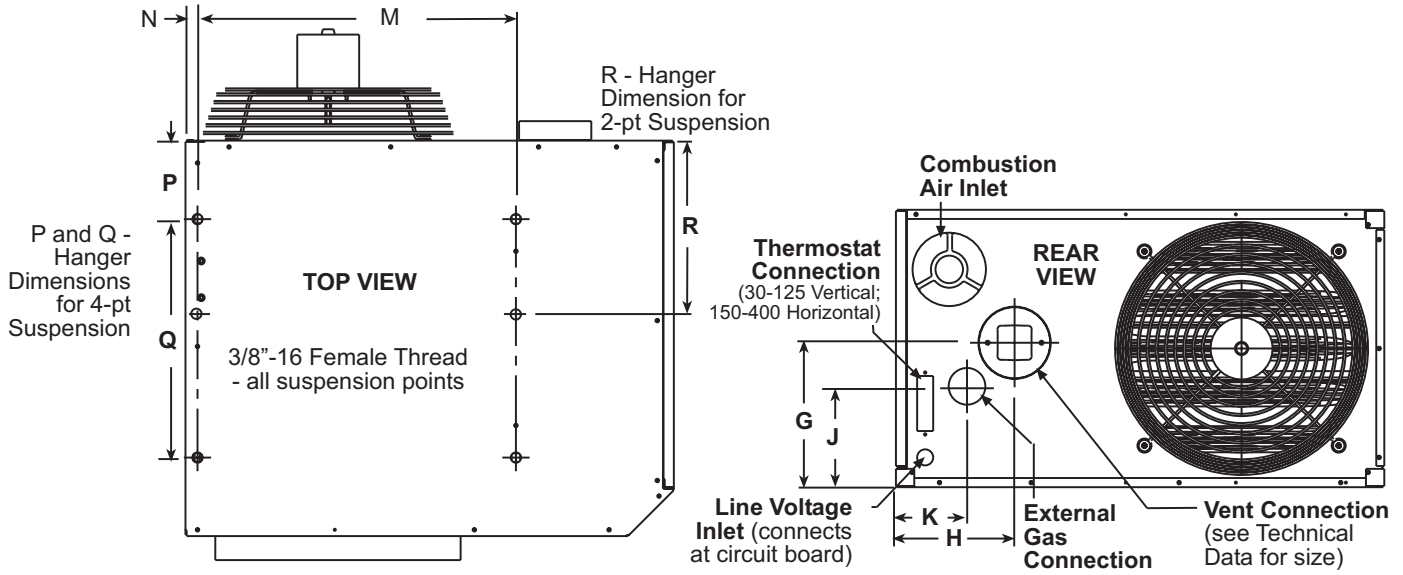

Model UDAP - GENERAL ARRANGEMENT AND DIMENSIONS (cont'd)**MODEL UDAP DIMENSIONS ($\pm 1/16"$)**

Size	A	B	C	D	E	F	G	H	J	K	M	N	P	Q	R
30, 45	12-1/8	26-5/8	10	13-13/16	26	21-9/16	5-3/16	6-1/2	2-11/16	3-7/8	17-3/8	11/16	4-5/16	13	9-9/16
60	15-1/8	26-5/8	13	13-13/16	27	21-9/16	7-7/8	6-1/2	5-1/2	3-7/8	17-3/8	11/16	4-5/16	13	10-1/2
75	15-1/8	26-5/8	13	13-13/16	27-5/8	21-9/16	7-7/8	6-1/2	5-1/2	3-7/8	17-3/8	11/16	4-5/16	13	10-1/2
100	23-1/8	26-5/8	21	13-13/16	28-5/8	21-9/16	14-1/2	6-1/2	8-3/4	3-7/8	17-3/8	11/16	4-5/16	13	10-1/2
125	23-1/8	26-5/8	21	13-13/16	29-3/8	21-9/16	14-1/2	6-1/2	8-3/4	3-7/8	17-3/8	11/16	4-5/16	13	10-1/2
150, 175, 200	20-1/8	38-3/16	16	23	42	35-3/8	8-1/2	8-1/4	5-7/16	6-1/2	25-11/16	1-3/8	8-3/16	22-3/16	16-3/8
225, 250	26-1/8	38-3/16	22	23	42	35-3/8	13-1/16	8-13/16	9	6-1/2	25-11/16	1-3/8	8-3/16	22-3/16	15-5/8
300, 350, 400	34-1/8	41	30	23	42	35-3/8	17-1/16	9	11-13/16	7-5/16	27-11/16	1-3/8	8-3/16	22-3/16	16-3/16

MODEL UDAP DIMENSIONS (± 2 mm)

Size	A	B	C	D	E	F	G	H	J	K	M	N	P	Q	R
30, 45	308	676	254	351	660	548	132	165	68	98	441	17	110	330	243
60	384	676	330	351	686	548	200	165	140	98	441	17	110	330	267
75	384	676	330	351	702	548	200	165	140	98	441	17	110	330	267
100	587	676	533	351	727	548	368	165	222	98	441	17	110	330	267
125	587	676	533	351	746	548	368	165	222	98	441	17	110	330	267
150, 175, 200	511	970	406	584	1067	899	216	210	138	165	652	35	208	564	416
225, 250	664	970	559	584	1067	899	332	224	229	165	652	35	208	564	397
300, 350, 400	867	1041	762	584	1067	899	433	229	300	186	703	35	208	564	411

CLEARANCES

Size	Top		Flue Connector		Access Panel		Non-Access Side		Bottom*		Rear	
	inches	mm	inches	mm	inches	mm	inches	mm	inches	mm	inches	mm
30-125	1	25	6	152	18	457	1	25	1	25	18	457
150-400	4	102	6	152	18	457	2	51	1	25	18	457

*Suspend the heater so that the bottom is a minimum of 5' (1.5M) above the floor.

REZNOR® **V3**

Model UDBS Separated Combustion, High Static Blower Type Unit Heaters for Commercial/ Industrial Use



ANSI Z83.8

CSA 2.6



DESCRIPTION

Reznor® **V3** Series Model UDBS gas-fired separated combustion unit heaters are available in 14 sizes ranging from 30,000 to 400,000 BTUH gas input. Model UDBS heaters are designed for 82-83% thermal efficiency and are approved for commercial/industrial installations in the United States and Canada by the Canadian Standards Association (CSA).

Reznor® **V3** Series unit heaters have a refreshing new appearance with a glossy white cabinet finish and less visible hardware. Each size cabinet is easily suspended from four suspension points. The low voltage terminal strip on the outside of the cabinet makes connecting control wiring easy with no panels to remove. The addition of a "G" terminal to the low voltage strip, along with the new design of the circuit board, allows for blower only operation (without adding relays). All units have a factory installed gas line nipple to the exterior of the cabinet for easy gas service connection.

The preeminent new internal feature is the T_{CORE}²® heat exchanger and single burner combustion system. Other standard features include a single-stage gas valve, multi-try direct spark ignition with 100% lockout, pressure switch to verify vent flow, resiliently isolated venter motor, venter wheel with improved housing, a high temperature limit control, interlock door switch, and a built-in disconnect switch. Sizes 30-125 are equipped with a centrifugal blower and direct drive motor with multispeed taps. Sizes 30 and 45 are capable of handling up to .5" w.c. of external static pressure; Sizes 60-125 will handle up to .75" w.c. of external static pressure. Sizes 150-400 are equipped with a centrifugal blower with an adjustable belt drive and motor. All units are designed for use with optional 30° and 60° downturn nozzles with horizontal and vertical louvers. Operation is controlled through an integrated circuit board. The circuit board monitors heater operation and has LED diagnostic indicator lights to identify abnormalities in control functions.

The **1ST ever separated combustion system** in the commercial/industrial heating industry **was introduced on a Reznor heater** in the 1960's, and that proven technology is continued in this new separated combustion product. Model UDBS separated combustion units require installation of a specially designed combustion air/vent system including the unique concentric adapter box that allows for only one building penetration for both the vent and combustion air.

The new **V3** Series unit heaters are designed to provide all the features you expect in a Reznor heater plus improved efficiency, easier installation, and a new look ~ **both inside and out.**

Form RZ-NA-C-UH Page 10

STANDARD FEATURES

- Certified for commercial/industrial heating applications
- 82-83% Thermal efficient ~ **TOP in its class!**
- 45-75°F Rise range - Sizes 30-350
- 50-80°F Rise range - Size 400
- **NEW** T_{CORE}²® titanium stabilized aluminized steel heat exchanger
- **NEW** patented** T_{CORE}²® single burner combustion system including a one-piece burner assembly
- 115/1/60 Supply voltage
- 115 Volt open dripproof blower motor with internal overload protection - Sizes 30-125
- 115 Volt open dripproof blower motor with internal overloads and definite purpose motor contactor - Sizes 150-400
- Direct drive blower with multispeed taps - Sizes 30-125
- Adjustable belt drive blower - Sizes 150-400
- Transformer for 24-volt controls
- Integrated circuit board with diagnostic indicator lights
- Blower relay (included on the circuit board)
- Multi-try direct spark ignition with 100% lockout
- Single-stage natural gas valve (field adjustable for operation to 6,000 ft elevation)
- Vibration/noise isolated venter motors
- Sealed compartment houses all electrical components
- 4-pt Suspension
- Built-in disconnect switch - Sizes 30-125, 20A@115V rating; Sizes 150-400 30A@115V rating
- External terminal strip for 24-volt wiring
- Sealed junction box for supply wiring
- External gas connection
- Fully gasketed door panel with safety door switch
- Improved cabinet design with less visible hardware and a **NEW** Reznor appearance

OPTIONAL FEATURES - FACTORY INSTALLED

- Equipped for propane gas
- Single stage propane gas valve (field adjustable for operation to 6,000 ft elevation)
- Two-stage (70% low fire) natural or propane gas valve - Sizes 60-400
- 409 or 316 Stainless steel heat exchanger
- 208 and 230 Single phase voltage; 208, 230, 480, and 575 Three phase voltage - Sizes 150-400 (step down transformer shipped separate for field installation for 480 and 575 units)
- Adjustable belt drive and motor for up to .5" w.c. external static pressure - Sizes 150-400
- Totally enclosed blower motor - Sizes 150-250
- Belt and blower guards

ACCESSORIES - FIELD INSTALLED

- | | |
|--|--|
| ● *Horizontal or Vertical Combustion Air/Vent Kit including concentric adapter | ● Manual shutoff valves |
| ● Thermostat | ● High altitude kits (above 6,000 ft to 9,000 ft) |
| ● Thermostat guard with locking cover | ● Master/Slave controls for zoning up to six units |
| ● Vertical louvers ~ new design | ● Duct flange |
| ● Downturn nozzle (30° or 60° deflection, with and without vertical louvers) ~ new design | ● Polytube adapters |
| ● Gas conversion kits | ● Blower and belt guards |
| | ● Hanger kits for 1" pipe |
| | ● Stepdown transformer for 230 or 460 voltage - Sizes 30-125 |

* Selection of either a horizontal or vertical combustion air/vent kit is required.

** U.S. Patent No. 6,889,686

MODEL UDBS TECHNICAL DATA - Sizes 30 - 125

Size		30	45	60	75	100	125
Input Heating Capacity	BTUH	30,000	45,000	60,000	75,000	105,000	120,000
	kw/h	8.8	13.2	17.6	22.0	30.8	35.2
Thermal Efficiency (%)		82	82	82	82	83	83
Output Heating Capacity ^A	BTUH	24,600	36,900	49,200	61,500	87,150	99,600
	kw/h	7.2	10.8	14.4	18.0	25.6	29.2
Gas Connection (inches) ^B	Natural	1/2	1/2	1/2	1/2	1/2	1/2
	Propane	1/2	1/2	1/2	1/2	1/2	1/2
Vent Connection ^C (inches diameter)		4	4	4	4	4	4
Combustion Air Inlet ^C (inches diameter)		4	4	4	4	4	4
Control Amps (24 volt)		1.0	1.0	1.0	1.0	1.0	1.0
Full Load Amps (with standard HP 115V motor)		3.7	3.7	7.1	7.1	13.0	13.0
Maximum Over Current Protection (115V) ^D		15	15	15	15	30	30
Normal Power Consumption (watts @ full load, medium speed)		215	215	447	447	537	537
Minimum Discharge Air Temperature Rise	°F	45	45	45	45	45	45
Maximum Discharge Air Temperature Rise	°F	75	75	75	75	75	75
Maximum Air Volume	CFM	506	759	1012	1265	1793	2049
	M ³ /minute	14.3	21.5	28.7	35.8	50.8	58.0
Minimum Air Volume	CFM	304	456	607	759	1076	1230
	M ³ /minute	8.6	12.9	17.2	21.5	30.5	34.8
Discharge Air Opening Area	Ft ²	0.96	0.96	1.25	1.25	2.01	2.01
	M ²	0.09	0.09	0.12	0.12	0.19	0.19
Maximum Output Velocity	FPM	527	791	810	1012	892	1020
	M/minute	159	239	239	299	267	305
Minimum Output Velocity	FPM	316	475	486	607	535	612
	M/minute	96	143	143	179	160	183
Standard Blower Motor HP		1/6	1/6	1/3	1/3	3/4	3/4
Blower Size	inches	9 X 6	9 X 6	9 X 6	9 X 6	10 X 10	10 X 10
Approximate Net Weight	lbs	72	77	89	94	131	136
	kg	33	35	40	43	59	62
Approximate Ship Weight	lbs	90	95	110	115	176	181
	kg	41	43	50	52	80	82

MODEL UDBS TECHNICAL DATA Sizes 150 - 400

Size		150	175	200	225	250	300	350	400
Input Heating Capacity	BTUH	150,000	175,000	200,000	225,000	250,000	300,000	350,000	400,000
	kw/h	43.9	51.2	58.6	65.9	73.2	87.8	102.5	117.1
Thermal Efficiency (%)		83	83	83	83	83	83	83	82
Output Heating Capacity ^A	BTUH	124,500	145,250	166,000	186,750	207,500	249,000	290,500	328,000
	kw/h	36.4	42.5	48.6	54.7	60.8	72.9	85.1	96.0
Gas Connection (inches) ^B	Natural	1/2	1/2	1/2	3/4	3/4	3/4	3/4	3/4
	Propane	1/2	1/2	1/2	3/4	3/4	3/4	3/4	3/4
Vent Connection ^C (inches diameter)		5	5	5	5	5	6	6	6
Combustion Air Inlet ^C (inches diameter)		6	6	6	6	6	6	6	6
Control Amps (24 volt)		1.0	1.0	1.0	1.0	1.0	1.0	1.0	1.0
Full Load Amps (w/std HP 115V motor)		5.9	6.3	10.5	12.7	12.7	17.7	27.3	27.3
Maximum Over Current Protection (115V) ^D		15	15	25	30	30	40	60	60
Normal Power Consumption (watts)		230	415	485	675	675	1260	1635	1635
Minimum Discharge Air Temperature Rise (°F)		45	45	45	45	45	45	45	50
Maximum Discharge Air Temperature Rise (°F)		75	75	75	75	75	75	75	80
Maximum Air Volume	CFM	2562	2989	3416	3843	4270	5123	5977	6185
	M ³ /minute	72.5	84.6	96.7	108.8	120.9	145.1	169.2	175.1
Minimum Air Volume	CFM	1537	1793	2049	2306	2562	3074	3586	4100
	M ³ /minute	43.5	50.8	58.0	65.3	72.5	87.0	101.5	116.1
Discharge Air Opening Area	Ft ²	2.56	2.56	2.56	3.51	3.51	4.79	4.79	4.79
	M ²	0.24	0.24	0.24	0.33	0.33	0.45	0.45	0.45
Maximum Output Velocity	FPM	1001	1168	1334	1095	1217	1070	1248	1291
	M/minute	305	356	407	334	371	326	380	393
Minimum Output Velocity	FPM	600	700	800	657	730	642	749	856
	M/minute	183	213	244	200	223	196	228	261
Standard Open 115V Blower Motor HP		1/4	1/2	1/2	3/4	3/4	1-1/2	2	2
Blower Size	inches	12 x 12	12 x 12	12 x 12	15 x 11	15 x 11	15 x 15	15 x 15	15 x 15
Approximate Net Weight	lbs	255	275	275	320	335	375	410	425
	kg	116	125	125	145	152	170	186	193
Approximate Ship Weight	lbs	315	335	335	400	415	475	510	525
	kg	143	152	152	181	188	215	231	238

^A CSA rating for altitudes to 2000 ft. ^B Size shown is for gas connection to a single stage gas valve, not supply line size. ^C Smaller and/or larger vent and combustion air pipe diameters may be allowed; refer to the Venting Installation Manual for Separated Combustion Units, Form I-V-SC. If vent diameter is different from vent connection, reducer/enlargers will be field-required. ^D MODP = 2.25 x (largest motor FLA) + smallest motor FLA. Answer is rounded to the nearest commercially available circuit breaker.

Model UDBS - GENERAL ARRANGEMENT AND DIMENSIONS

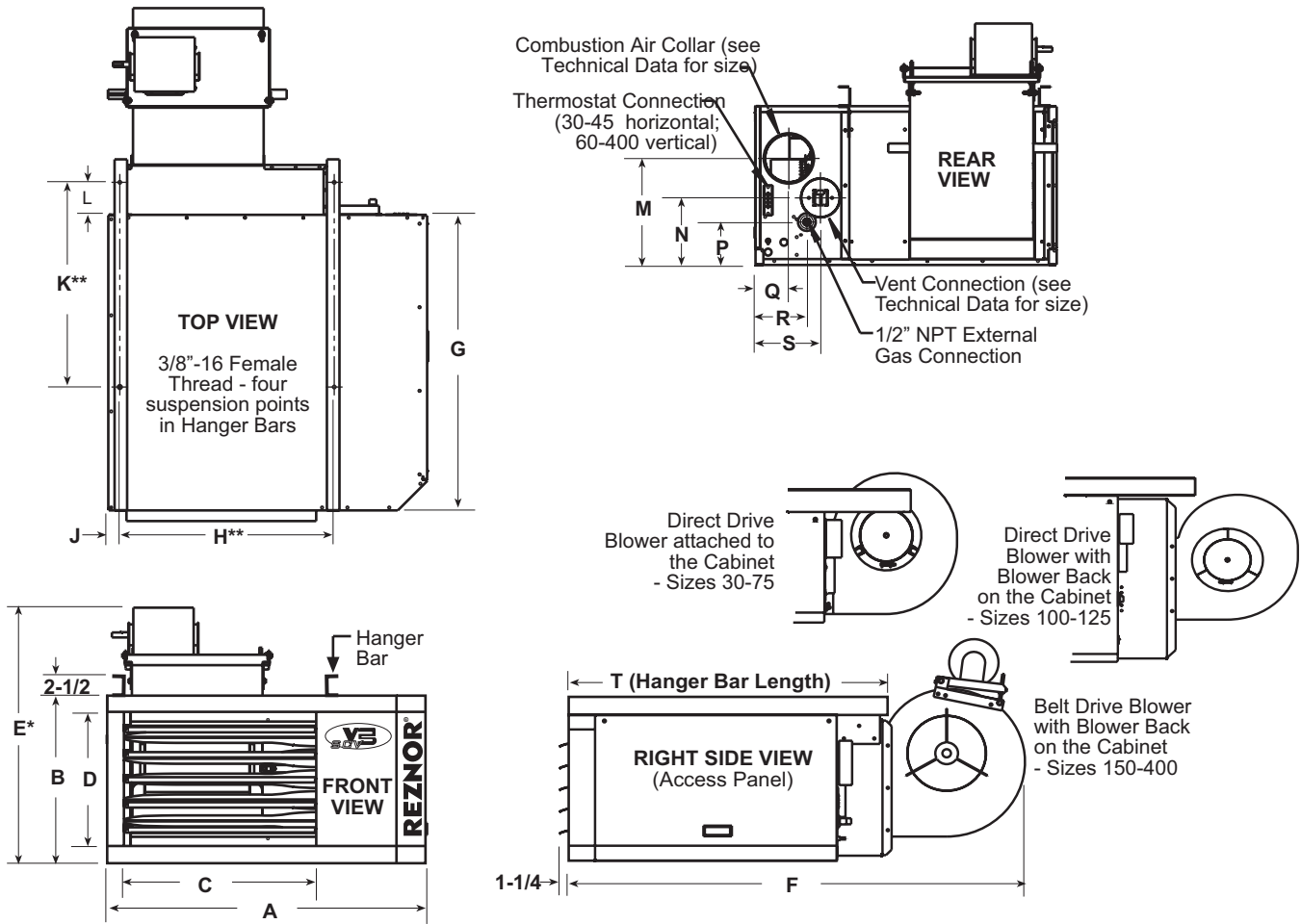

MODEL UDBS DIMENSIONS (± 1/16")

Size	A	B	C	D	E*	F	G	H**	J	K**	L	M	N	P	Q	R	S	T
30, 45	26-5/8	12-1/8	13-13/16	10	16-3/8	36-1/8	21-9/16	17-3/8	11/16	22-1/2	6-1/2	9-3/16	5-3/16	2-11/16	2-7/8	3-7/8	6-1/2	31
60	26-5/8	15-1/8	13-13/16	13	17-7/8	36-1/8	21-9/16	17-3/8	11/16	22-1/2	6-1/2	11-7/8	7-7/8	5-1/2	2-7/8	3-7/8	6-1/2	31
75	26-5/8	15-1/8	13-13/16	13	17-7/8	36-1/8	21-9/16	17-3/8	11/16	22-1/2	5-1/2	11-7/8	7-7/8	5-1/2	2-7/8	3-7/8	6-1/2	31
100	26-5/8	23-1/8	13-13/16	21	23-1/4	43-5/8	21-9/16	17-3/8	11/16	22-1/2	8-1/2	18-1/2	14-1/2	8-3/4	2-7/8	3-7/8	6-7/16	31
125	26-5/8	23-1/8	13-13/16	21	23-1/4	43-5/8	21-9/16	17-3/8	11/16	22-1/2	7-1/2	18-1/2	14-1/2	8-3/4	2-7/8	3-7/8	6-7/16	31
150, 175	38-1/8	20-1/8	23	16	30-9/16	60-1/8	35-3/8	25-5/8	1-5/16	24-1/2	3-7/8	13-1/2	8-1/2	5-7/16	4-1/4	6-1/2	8-1/4	42
200	38-1/8	20-1/8	23	16	30-9/16	60-1/8	35-3/8	25-5/8	1-5/16	24-1/2	3-7/8	14-9/16	9-9/16	5-7/16	4-5/16	6-1/2	8-5/16	42
225, 250	38-1/8	26-1/8	23	22	39-5/8	63-7/16	35-3/8	25-5/8	1-5/16	24-1/2	5-7/8	18-1/16	13-1/16	9	4-5/16	6-1/2	8-5/16	42
300, 350, 400	40-7/8	34-1/8	23	30	42-5/8	63-7/16	35-3/8	27-5/8	1-5/16	23-1/2	3-7/8	22-1/16	17-1/16	11-13/16	4-1/2	7-1/4	8-1/2	42

NOTES: * Sizes 150-400 - Dimension E varies with motor selection and belt adjustment.

** Dimensions H and K are the heater suspension points.

For Metric Dimensions, see next page.

Model UDBS - GENERAL ARRANGEMENT AND DIMENSIONS (cont'd)

MODEL UDBS DIMENSIONS (± 2mm)

Size	A	B	C	D	E*	F	G	H**	J	K**	L	M	N	P	Q	R	S	T
30, 45	676	511	351	254	416	918	548	441	17	572	165	233	132	68	73	98	165	787
60	676	384	351	330	454	918	548	441	17	572	165	302	200	140	73	98	165	787
75	676	384	351	330	454	918	548	441	17	572	140	302	200	140	73	98	165	787
100	676	587	351	533	591	1108	548	441	17	572	216	470	368	222	73	98	164	787
125	676	587	351	533	594	1108	548	441	17	572	191	470	368	222	73	98	164	787
150, 175	968	511	584	406	776	1527	899	651	33	622	98	343	216	138	108	165	210	1067
200	968	511	584	406	776	1527	899	651	33	622	98	370	243	138	110	165	211	1067
225, 250	968	664	584	559	1006	1611	899	651	33	622	149	459	332	229	110	165	211	1067
300, 350, 400	1038	867	584	762	1083	1611	899	702	33	597	98	560	433	300	114	184	216	1067

NOTES: * Sizes 150-400 - Dimension E varies with motor selection and belt adjustment.
 ** Dimensions H and K are the heater suspension points.

CLEARANCES

UDBS	Top*		Flue Connector		Access Panel		*Non-Access Side		Bottom		Rear	
	inches	mm	inches	mm	inches	mm	inches	mm	inches	mm	inches	mm
30-125	6	152	6	152	18	457	24	610	1	25	18	457
150-400	14	356	6	152	18	457	24	610	1	25	18	457

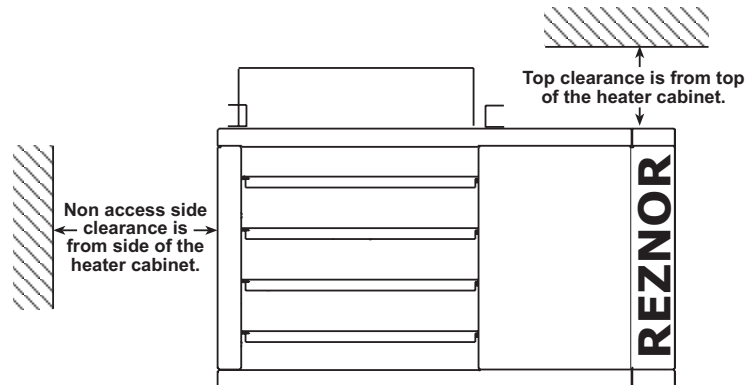

Refer to page 42 & 43 for venting/inlet air requirements for Reznor Separated Combustion Units

REZNOR®

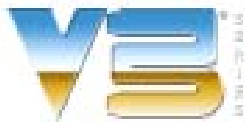

ANSI Z83.8

CSA 2.6

DESCRIPTION

Reznor® V3 Series Model UDBP gas-fired unit heaters are available in 14 sizes ranging from 30,000 to 400,000 BTUH gas input. Model UDBP heaters are designed for 82-83% thermal efficiency and are approved for commercial/industrial installations in the United States and Canada by the Canadian Standards Association (CSA).

Reznor® V3 Series unit heaters have a refreshing new appearance with a glossy white cabinet finish and less visible hardware. Each size cabinet is easily suspended from four suspension points. The low voltage terminal strip on the outside of the cabinet makes connecting control wiring easy with no panels to remove. The addition of a "G" terminal to the strip, along with the new design of the circuit board, allows for blower only operation (without adding relays). All units have a factory installed gas line nipple to the exterior of the cabinet for easy gas service connection.

The preeminent new internal feature is the TCORE²® heat exchanger and single burner combustion system. Other standard features include a single-stage gas valve, multi-try direct spark ignition with 100% lockout, pressure switch to verify vent flow, resiliently isolated venter motor, venter wheel with improved housing, and a high temperature limit control. Sizes 30-125 are equipped with a centrifugal blower and direct drive motor with multispeed taps. Sizes 30 and 45 are capable of handling up to .5" w.c. of external static pressure; Sizes 60-125 will handle up to .75" w.c. of external static pressure. Sizes 150-400 are equipped with a centrifugal blower with an adjustable belt drive and motor. All units are designed for use with optional 30° and 60° downturn nozzles with horizontal and vertical louvers. Operation is controlled through an integrated circuit board. The circuit board monitors heater operation and has LED diagnostic indicator lights to identify abnormalities in control functions.

The new V3 Series unit heaters are designed to provide all the features you expect in a Reznor heater plus improved efficiency, easier installation, and a new look ~ **both inside and out.**

Model UDBP

Power Vented, High Static Blower Type Unit Heaters for Commercial/Industrial Use

STANDARD FEATURES

- Certified for commercial/industrial heating applications
- 82-83% Thermal efficient ~ **TOP in its class!**
- 45-75°F Rise range - Sizes 30-350
50-80°F Rise range - Size 400
- **NEW** TCORE²® titanium stabilized aluminized steel heat exchanger
- **NEW** patented** TCORE²® single burner combustion system including a one-piece burner assembly
- 115/1/60 Supply voltage
- 115 Volt open dripproof blower motor with internal overload protection - Sizes 30-125
- 115 Volt open dripproof blower motor with internal overloads and definite purpose motor contactor - Sizes 150-400
- Direct drive blower with multispeed taps - Sizes 30-125
- Adjustable belt drive blower - Sizes 150-400
- Transformer for 24-volt controls
- Integrated circuit board with diagnostic indicator lights
- Blower relay (included on the circuit board)
- Multi-try direct spark ignition with 100% lockout
- Single-stage natural gas valve (field adjustable for operation to 6,000 ft elevation)
- Vibration/noise isolated venter motors ~ **designed for low noise operation**
- 4-pt Suspension
- External terminal strip for 24-volt wiring
- External gas connection
- Improved cabinet design with less visible hardware and a **NEW** Reznor appearance

OPTIONAL FEATURES - FACTORY INSTALLED

- Equipped for propane gas
- Single-stage propane gas valve (field adjustable for operation to 6,000 ft elevation)
- Two-stage (70% low fire) natural or propane gas valve - Sizes 60-400
- 409 or 316 Stainless steel heat exchangers
- 208 and 230 Single phase voltage; 208, 230, 480, and 575 Three phase voltage - Sizes 150-400 (step down transformer shipped separate for field installation for 480 and 575 units)
- Adjustable belt drive and motor for up to .5" w.c. external static pressure - Sizes 150-400
- Totally enclosed blower motor - Sizes 150-400
- Belt and blower guards

ACCESSORIES - FIELD INSTALLED

- | | |
|--|--|
| ● Vent cap | ● High altitude kits (above 6,000 ft to 9,000 ft) |
| ● Thermostat | ● Master/Slave controls for zoning up to six units |
| ● Thermostat guard with locking cover | ● Duct flange |
| ● Vertical louvers ~ new design | ● Polytube adapters |
| ● Downturn nozzle (30° or 60° deflection, with and without vertical louvers) ~ new design | ● Blower and belt guards |
| ● Gas conversion kits (natural and propane) | ● Hanger kits for 1" pipe |
| | ● Stepdown transformer for 230 or 460 voltage - Sizes 30-125 |
| | ● Manual shutoff valves |

** U.S. Patent No. 6,889,686

MODEL UDBP TECHNICAL DATA - Sizes 30 - 125

Size		30	45	60	75	100	125
Input Heating Capacity	BTUH	30,000	45,000	60,000	75,000	105,000	120,000
	kw/h	8.8	13.2	17.6	22.0	30.8	35.2
Thermal Efficiency (%)		82	82	82	82	83	83
Output Heating Capacity ^A	BTUH	24,600	36,900	49,200	61,500	87,150	99,600
	kw/h	7.2	10.8	14.4	18.0	25.6	29.2
Gas Connection (inches) ^B	Natural	1/2	1/2	1/2	1/2	1/2	1/2
	Propane	1/2	1/2	1/2	1/2	1/2	1/2
Vent Connection Size ^C (inches diameter)		4	4	4	4	4	4
Control Amps (24 volt)		1.0	1.0	1.0	1.0	1.0	1.0
Full Load Amps (with standard HP 115V motor)		3.7	3.7	7.1	7.1	13.0	13.0
Maximum Over Current Protection (115V) ^D		15	15	15	15	30	30
Normal Power Consumption (watts @ full load, medium speed)		215	215	447	447	537	537
Minimum Discharge Air Temperature Rise	°F	45	45	45	45	45	45
Maximum Discharge Air Temperature Rise	°F	75	75	75	75	75	75
Maximum Air Volume	CFM	506	759	1012	1265	1793	2049
	M ³ /minute	14.3	21.5	28.7	35.8	50.8	58.0
Minimum Air Volume	CFM	304	456	607	759	1076	1230
	M ³ /minute	8.6	12.9	17.2	21.5	30.5	34.8
Discharge Air Opening Area	FT ²	0.96	0.96	1.25	1.25	2.01	2.01
	M ²	0.09	0.09	0.12	0.12	0.19	0.19
Maximum Output Velocity	FPM	527	791	810	1012	892	1020
	M/minute	159	239	239	299	267	305
Minimum Output Velocity	FPM	316	475	486	607	535	612
	M/minute	96	143	143	179	160	183
Standard Blower Motor HP		1/6	1/6	1/3	1/3	3/4	3/4
Blower Size	inches	9 X 6	9 X 6	9 X 6	9 X 6	10 X 10	10 X 10
Approximate Net Weight	lbs	72	77	89	94	131	136
	kg	33	35	40	43	59	62
Approximate Ship Weight	lbs	90	95	110	115	176	181
	kg	41	43	50	52	80	82

MODEL UDBP TECHNICAL DATA Sizes 150 - 400

Size		150	175	200	225	250	300	350	400
Input Heating Capacity	BTUH	150,000	175,000	200,000	225,000	250,000	300,000	350,000	400,000
	kw/h	43.9	51.2	58.6	65.9	73.2	87.8	102.5	117.1
Thermal Efficiency (%)		83	83	83	83	83	83	83	82
Output Heating Capacity ^A	BTUH	124,500	145,250	166,000	186,750	207,500	249,000	290,500	328,000
	kw/h	36.4	42.5	48.6	54.7	60.8	72.9	85.1	96.0
Gas Connection (inches) ^B	Natural	1/2	1/2	1/2	3/4	3/4	3/4	3/4	3/4
	Propane	1/2	1/2	1/2	3/4	3/4	3/4	3/4	3/4
Vent Connection Size ^C (inches diameter)		5	5	5	5	5	6	6	6
Control Amps (24 volt)		1.0	1.0	1.0	1.0	1.0	1.0	1.0	1.0
Full Load Amps (w/std HP 115V motor)		5.9	9.6	10.5	12.7	12.7	17.7	27.3	27.3
Maximum Over Current Protection (115V) ^D		15	20	25	30	30	40	60	60
Normal Power Consumption (watts)		230	415	485	675	675	1260	1635	1635
Minimum Discharge Air Temperature Rise (°F)		45	45	45	45	45	45	45	50
Maximum Discharge Air Temperature Rise (°F)		75	75	75	75	75	75	75	80
Maximum Air Volume	CFM	2562	2989	3416	3843	4270	5123	5977	6185
	M ³ /minute	72.5	84.6	96.7	108.8	120.9	145.1	169.2	175.1
Minimum Air Volume	CFM	1537	1793	2049	2306	2562	3074	3586	4100
	M ³ /minute	43.5	50.8	58.0	65.3	72.5	87.0	101.5	116.1
Discharge Air Opening Area	FT ²	2.56	2.56	2.56	3.51	3.51	4.79	4.79	4.79
	M ²	0.24	0.24	0.24	0.33	0.33	0.45	0.45	0.45
Maximum Output Velocity	FPM	1001	1168	1334	1095	1217	1070	1248	1291
	M/minute	305	356	407	334	371	326	380	393
Minimum Output Velocity	FPM	600	700	800	657	730	642	749	856
	M/minute	183	213	244	200	223	196	228	261
Standard Open 115V Blower Motor HP		1/4	1/2	1/2	3/4	3/4	1-1/2	2	2
Blower Size	inches	12 x 12	12 x 12	12 x 12	15 x 11	15 x 11	15 x 15	15 x 15	15 x 15
Approximate Net Weight	lbs	255	275	275	320	335	375	410	425
	kg	116	125	125	145	152	170	186	193
Approximate Ship Weight	lbs	315	335	335	400	415	475	510	525
	kg	143	152	152	181	188	215	231	238

^A CSA rating for altitudes to 2000 ft. ^B Size shown is for gas connection to a single stage gas valve, not supply line size. ^C Smaller or larger vent pipe diameters may be allowed; refer to the Venting Installation Manual, Form I-V-PV. If vent diameter is different from vent connection, reducer/enlargers will be field-required. ^D MODP = 2.25 x (largest motor FLA) + smallest motor FLA. Answer is rounded to the nearest commercially available circuit breaker.

Model UDBP - GENERAL ARRANGEMENT AND DIMENSIONS

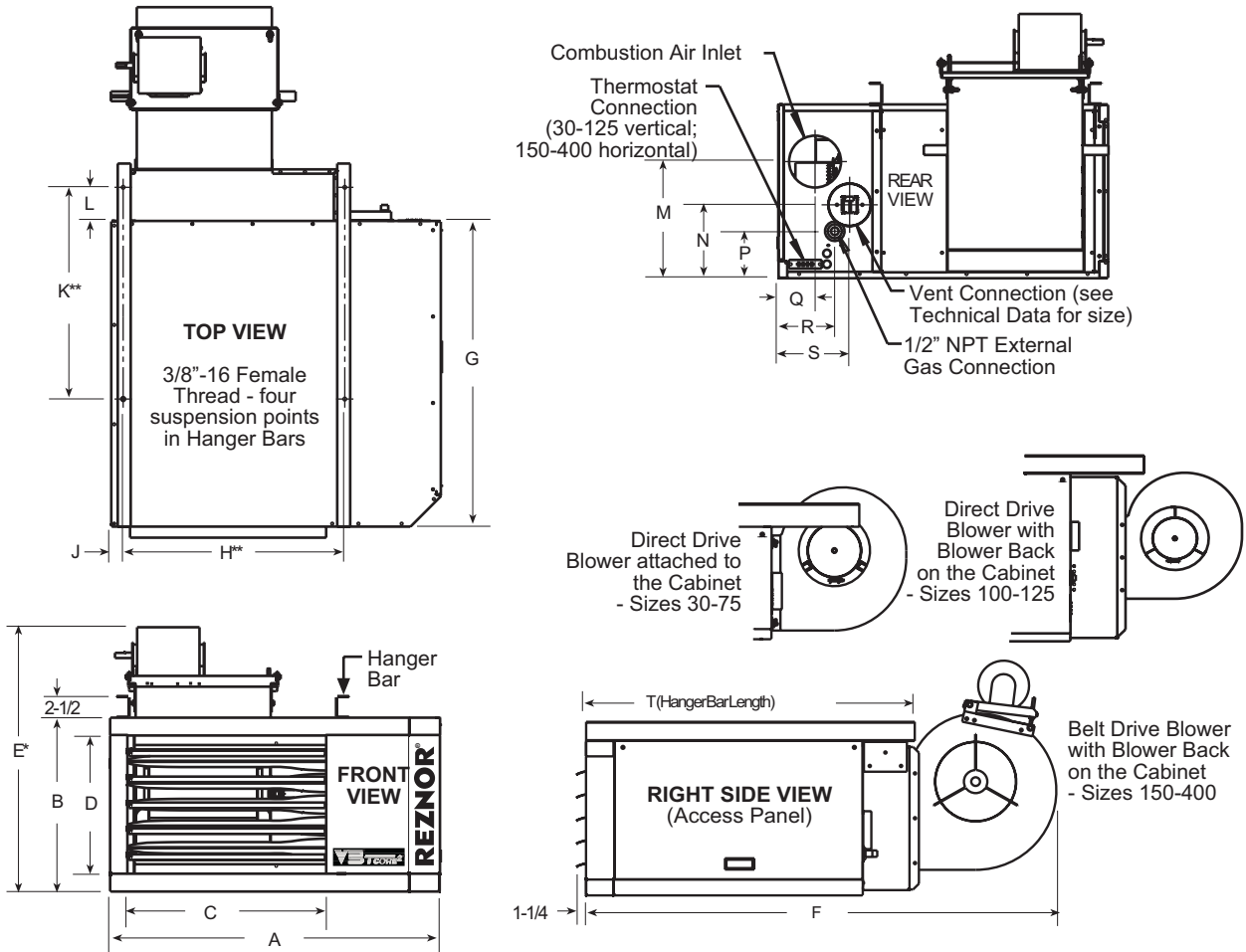

Model UDBP - GENERAL ARRANGEMENT AND DIMENSIONS (cont'd)

MODEL UDBP DIMENSIONS ($\pm 1/16"$)

Size	A	B	C	D	E	F	G	H	J	K	L	M	N	P	Q	R	S	T
30, 45	26-5/8	12-1/8	13-13/16	10	16-3/8	36-1/8	21-9/16	17-3/8	11/16	22-1/2	6-1/2	9-3/16	5-3/16	2-11/16	2-7/8	3-7/8	6-1/2	31
60	26-5/8	15-1/8	13-13/16	13	17-7/8	36-1/8	21-9/16	17-3/8	11/16	22-1/2	6-1/2	11-7/8	7-7/8	5-1/2	2-7/8	3-7/8	6-1/2	31
75	26-5/8	15-1/8	13-13/16	13	17-7/8	36-1/8	21-9/16	17-3/8	11/16	22-1/2	5-1/2	11-7/8	7-7/8	5-1/2	2-7/8	3-7/8	6-1/2	31
100	26-5/8	23-1/8	13-13/16	21	23-1/4	43-5/8	21-9/16	17-3/8	11/16	22-1/2	8-1/2	18-1/2	14-1/2	8-3/4	2-7/8	3-7/8	6-7/16	31
125	26-5/8	23-1/8	13-13/16	21	23-1/4	43-5/8	21-9/16	17-3/8	11/16	22-1/2	7-1/2	18-1/2	14-1/2	8-3/4	2-7/8	3-7/8	6-7/16	31
150, 175	38-1/8	20-1/8	23	16	30-9/16	60-1/8	35-3/8	25-5/8	1-5/16	24-1/2	3-7/8	13-1/2	8-1/2	5-7/16	4-1/4	6-1/2	8-1/4	42
200	38-1/8	20-1/8	23	16	30-9/16	60-1/8	35-3/8	25-5/8	1-5/16	24-1/2	3-7/8	14-9/16	9-9/16	5-7/16	4-5/16	6-1/2	8-5/16	42
225, 250	38-1/8	26-1/8	23	22	39-5/8	63-7/16	35-3/8	25-5/8	1-5/16	24-1/2	5-7/8	18-1/16	13-1/16	9	4-5/16	6-1/2	8-5/16	42
300, 350, 400	40-7/8	34-1/8	23	30	42-5/8	63-7/16	35-3/8	27-5/8	1-5/16	23-1/2	3-7/8	22-1/16	17-1/16	11-13/16	4-1/2	7-1/4	8-1/2	42

MODEL UDBP DIMENSIONS (± 2 mm)

Size	A	B	C	D	E*	F	G	H**	J	K**	L	M	N	P	Q	R	S	T
30, 45	676	308	351	254	416	918	548	441	17	572	165	233	132	68	73	98	165	787
60	676	384	351	330	454	918	548	441	17	572	165	302	200	140	73	98	165	787
75	676	384	351	330	454	918	548	441	17	572	140	302	200	140	73	98	165	787
100	676	587	351	533	591	1108	548	441	17	572	216	470	368	222	73	98	164	787
125	676	587	351	533	594	1108	548	441	17	572	191	470	368	222	73	98	164	787
150, 175	968	511	584	406	776	1527	899	651	33	622	98	343	216	138	108	165	210	1067
200	968	511	584	406	776	1527	899	651	33	622	98	370	243	138	110	165	211	1067
225, 250	968	664	584	559	1006	1611	899	651	33	622	149	459	332	229	110	165	211	1067
300, 350, 400	1038	867	584	762	1083	1611	899	702	33	597	98	560	433	300	114	184	216	1067

NOTES:

* Sizes 150-400 - Dimension E varies with motor selection and belt adjustment.

** Dimensions H and K are the heater suspension points.

CLEARANCES

UDBS	Top*		Flue Connector		Access Panel		*Non-Access Side		Bottom		Rear	
	inches	mm	inches	mm	inches	mm	inches	mm	inches	mm	inches	mm
30-125	6	152	6	152	18	457	24	610	1	25	18	457
150-400	14	356	6	152	18	457	24	610	1	25	18	457

*Clearances are measured from the heater cabinet.

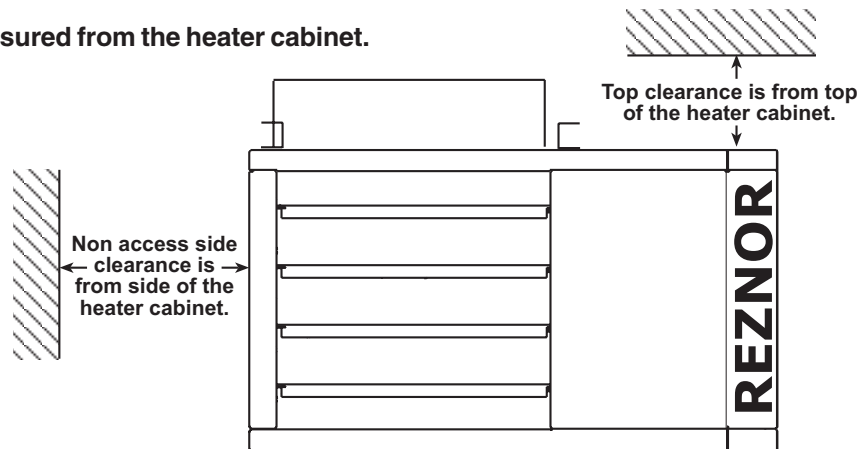

REZNOR®

MODEL SHE

GAS FIRED, HIGH EFFICIENCY SEPARATED COMBUSTION, CONDENSING UNIT HEATERS



ANSI Z83.8



CAN/CGA 2.6-M96

ISO 9001
registered by

GASTEC

DESCRIPTION

The Reznor® Model SHE Series gas-fired, power-vented, separated combustion, fan-type, high efficiency condensing unit heaters are available in three sizes -- 220,000, 304,000 and 394,000 BTUH gas input -- for use with either natural or propane gas. Model SHE unit heaters are designed to **provide better than 90% thermal efficiency**.

Standard features include an aluminized steel primary heat exchanger, a special corrosion-resistant alloy secondary heat exchanger, a burner rack assembly of die-formed burners, a power venter, a fan and motor with full fan guard, and a horizontal condensate drain connection. Standard controls include a single-stage gas valve, automatic hot surface ignition with 100% shutoff, a combustion air pressure switch, and a safety limit switch.

The heater is designed for suspension from four 3/8"-16 threaded hanger connections in the heater base. A condensate drain must be attached to the horizontal connection provided on the heater. Combustion air inlet/vent may be either vertical or horizontal using a specially designed concentric adapter/terminal.

Model SHE line of heaters is approved for installation in The United States and Canada by the Canadian Standards Association (CSA).

STANDARD FEATURES

- Orifices for natural gas
- Primary heat exchanger of aluminized steel
- Secondary heat exchanger of corrosion resistant alloy
- Aluminized steel burner rack with die-formed burners
- Hot surface ignition with 100% lockout
- Single-stage combination gas valve
- 115/1/60 supply voltage
- 115 volt fan motor with internal overload protection
- Fan and limit controls
- Pressure switch to verify vent flow
- Power venter
- 24-volt control voltage transformer
- Horizontal flue and combustion air connections
- Horizontal condensation drain connection with 1-1/2", threaded fitting
- Individually adjustable horizontal louvers
- Full safety fan guard
- 4-point 1/2"-16 threaded hangers

ACCESSORIES - Field Installed

- Horizontal or Vertical vent/combustion air intake concentric adapter/terminal, 4" or 6" (**installation required**)
- Thermostat
- Gas conversion kits

High Efficiency Operating Principle

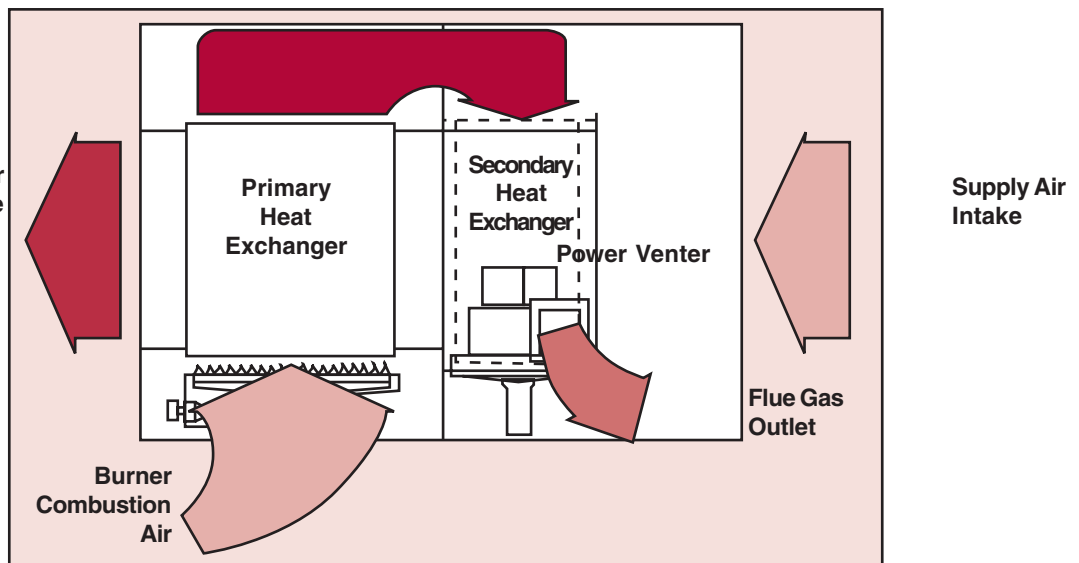

TECHNICAL DATA - Model SHE

Size	225		300		400	
Heating Input - BTUH (kW)	220,000	(64.5)	304,000	(89.1)	394,000	(115.5)
Thermal Output	205,000	(60.1)	283,000	(82.9)	365,000	(107.0)
Thermal Efficiency	93%		93%		93%	
Control Amps (24-volt)	1.1		1.1		1.1	
Full-Load Amps (115 volt)	6.6		5.8		7.8	
Motor HP	1/2		1/2		1.0	
Motor RPM	1,000		1,000		1,000	
Fian Diameter - in. (mm)	24	(610)	28	(711)	28	(711)
Air Volume - CFM (M ³ /hr)	3,320	(5,640)	4,197	(7,130)	5,656	(9,610)
Gas Connection - Natural Gas or Propane (inches)	3/4		3/4		3/4	
Condensation	0.9	(3.4)	1.2	(4.5)	1.6	(6.0)
Approximate Net Weight	375	(170)	463	(210)	595	(270)
Approximate Shipping Weight	463	(210)	563	(255)	728	(330)

DIMENSIONS, + or - 1/8" (3mm)

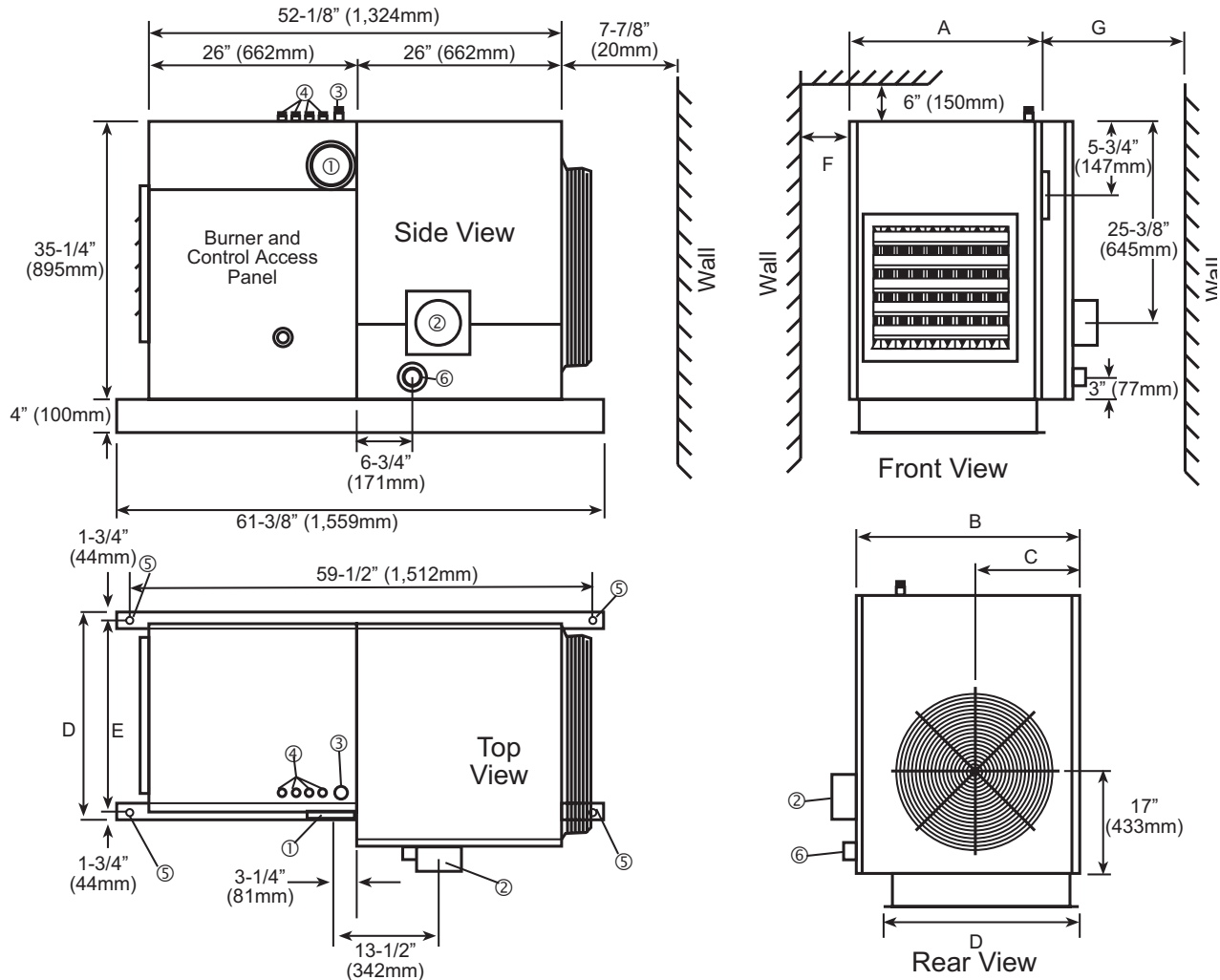

Dimensions/Key:

- 1 Combustion Air Intake Collar - 6" (170 mm) PVC Pipe
- 2 Flue Outlet Collar - 6" (170 mm) PVC Pipe
- 3 Inlet Gas Service Connection - 3/4" (19 mm)
- 4 Electrical Supply and Controls Inlets
- 5 Suspension Points 1/2" (13 mm) diameter -- E x 59-1/2" (1,512mm)
- 6 Condensation Drain Connection - 1-1/2" ID (41 mm OD)

Size	225		300		400	
	in.	mm	in.	mm	in.	mm
A - Width of heating section	34 1/4	(870)	42 1/2	(1,080)	53 9/16	(1,360)
B - Width of fan cabinet	39 7/8	(1,013)	48 1/8	(1,223)	59 3/16	(1,503)
C - Center of fan to opposite side	15 15/16	(405)	20 1/16	(510)	25 9/16	(650)
D - Width overall of base frame	34 7/16	(874)	42 11/16	(1,084)	53 11/16	(1,364)
E - Width of suspension points	30 15/16	(786)	39 3/16	(996)	50 1/4	(1,276)
F - Opposite side clearance	5 7/8	(150)	5 7/8	(150)	5 7/8	(150)
G - Minimum service clearance	35 7/16	(900)	43 5/16	(1,100)	55 1/8	(1,400)

REZNOR®**MODEL F****GAS-FIRED, GRAVITY-VENTED,
FAN-TYPE UNIT HEATER FOR
COMMERCIAL/INDUSTRIAL USE****ANSI Z83.8****CAN/CGA 2.6****DESCRIPTION**

Reznor® Series 100, Model F gas-fired, gravity-vented unit heaters are designed for 80% thermal efficiency and are designed for use with natural or propane gas, as specified, in sizes from 25,000 to 400,000 BTUH gas input. .

Model F unit heaters are designed for ceiling suspension with a propeller fan for air delivery.

Standard features include a manual match-lit pilot with 100% shutoff and a single-stage, 24-volt gas valve. A terminal strip connector facilitates field connection to a remote 24-volt thermostat for automatic operation. Each unit is provided with a fan control and all required limit safety controls, including an energy cutoff (ECO) device and a blocked vent switch.

These units are approved for installation in The United States and Canada by the Canadian Standards Association (CSA).

NOTE: Model F units for California require the addition of spark pilot Option AH2 or AH3.

STANDARD FEATURES

- Orifices for natural gas
- Aluminized steel heat exchanger
- Aluminized steel burner rack with stainless steel insert
- Manual match-lit pilot with 100% shutoff
- Single-stage combination gas valve (field adjustable for high altitude operation)
- 115/1/60 supply voltage
- 115 volt fan motor with internal overload protection
- Fan and limit safety controls
- Energy cutoff (ECO) device
- Blocked vent shutoff system
- 24-volt control voltage transformer
- Individually adjustable horizontal louvers
- Full safety fan guard

- Terminal strip connector for 24-volt field wiring
- Convenient bottom burner access
- 2-point 3/8"-16 threaded hanger connections
- Horizontal/vertical vent outlet

OPTIONAL FEATURES - Factory Installed

- Equipped for propane gas
- E-3 (409) stainless steel heat exchanger and burner
- Two-stage gas control (50% low fire) - Sizes 75-400
- Spark ignited, intermittent safety pilot with electronic flame supervision with or without timed lockout (timed lockout is required for propane gas)
- Manual summer/winter switch
- Burner air shutters
- 208/230 single phase supply voltage
- 220/240 volt/50 Hertz electrical operation
- Totally enclosed 115V motor
- Low ambient fan control relay

ACCESSORIES - Field Installed

- Power venter
- Vertical louvers
- Downturn air nozzle, 25-65° or 50-90° variable air deflector range (includes 4-point suspension kit)
- Thermostat and relay kits
- Air recirculation kits
- Manual summer/winter switch
- Multiple heater control
- 4-point suspension kit
- Unit-mounted thermostat bracket
- Step down transformer 230/115 or 460/115
- Burner air shutters
- Low ambient fan control relay kit
- Hanger kit to suspend from 1" pipe (2 or 4 point suspension)
- Single-stage and two-stage thermostats
- Thermostat guard with locking cover
- Manual shutoff valve and union
- Gas conversion kit

NOTE: Not certified for residential use.

WARNING: Gas-fired appliances are not designed for use in hazardous atmospheres containing flammable vapors or combustible dust, or atmospheres containing chlorinated or halogenated hydrocarbons.

Installations in public garages or airplane hangars are permitted when in accordance with ANSI Z223.1 and NFPA 54 Codes or CAN1-B149 Codes and enforcing authorities.

NOTE: Regulated combination redundant gas valve consists of combination pilot solenoid valve, electric gas valve, pilot filter, pressure regulator, pilot shutoff, and manual shutoff, all in one body. Gas supply pressure must not exceed 0.5 psi (8 oz. or 14" w.c.). Minimum inlet pressure for natural gas is 5" w.c.; minimum inlet pressure for propane gas is 11" w.c.

TECHNICAL DATA - Model F

Size	25		50		75		100		125		165		200		250		300		400		
Heating Input - BTUH (kW)	25,000 (7.3)	50,000 (14.7)	75,000 (22.0)	100,000 (29.3)	125,000 (36.6)	165,000 (48.4)	200,000 (58.6)	250,000 (73.3)	300,000 (87.9)	400,000 (117.2)											
Thermal Output - BTUH (kw) (80%)*	20,000 (5.9)	40,000 (11.7)	60,000 (17.6)	80,000 (23.4)	100,000 (29.3)	132,000 (38.7)	160,000 (46.9)	200,000 (58.6)	240,000 (70.3)	320,000 (93.8)											
Vent Outlet Diameter	4" Rd	4" Rd	5" Oval	6" Oval	7" Oval	8" Oval	8" Oval	10" Oval	10" Oval	12" Oval											
Gas Connection - Natural Gas**	1/2"	1/2"	1/2"	1/2"	1/2"	1/2"	1/2"	1/2"	1/2"	3/4"											
Control Amps (24-volt)	0.33	0.33	0.33	0.33	0.33	0.23	0.23	0.23	0.23	0.2											
Full-Load Amps (115 volt)	0.8	1.3	1.9	2.8	2.9	4	4	2.5	4	7											
Normal Consumption (watts)	60	95	135	195	205	275	300	280	375	565											
Throw at 8' (2.4M) Mntg Ht - ft (M)***	35 (11)	39 (12)	48 (15)	60 (18)	73 (22)	78 (24)	85 (26)	96 (29)	108 (33)	120 (37)											
Motor HP****	Standard		1/50		1/35		1/15		1/30		1/20		1/16		1/6		1/4		1/2		
	Optional Enclosed		1/50		1/35		1/15		1/30		1/20		1/16		1/6		1/4		1/2		
Motor RPM	1550		1550		1550		1050		1050		1050		1050		850		850		850		
Fan Diameter - in. (mm)	10 (254)	10 (254)	12 (305)	14 (356)	16 (406)	16 (406)	20 (508)	22 (559)	22 (559)	24 (610)											
Air Volume - CFM (M ³ /hr)	380 (646)	650 (1,104)	980 (1,665)	1,250 (2,124)	1,600 (2,718)	2,200 (3,738)	2,800 (4,757)	3,360 (5,708)	3,800 (6,456)	4,940 (8,393)											
Outlet Velocity - FPM (M/s)	423 (2.1)	853 (4.3)	1,166 (5.9)	1,358 (6.9)	1,330 (6.8)	1,100 (5.6)	1,217 (6.2)	1,182 (6.0)	1,426 (7.2)	1,420 (7.2)											
Approximate Net Wt - lbs (kg)	72 (33)	79 (36)	88 (40)	97 (44)	127 (58)	149 (68)	170 (77)	204 (93)	221 (100)	276 (125)											
Approximate Shipping Wt - lbs (kg)	89 (40)	96 (44)	107 (49)	118 (54)	150 (68)	172 (78)	196 (89)	232 (105)	249 (113)	311 (141)											

*For U.S. installations, ratings for altitudes to 2000 ft. Above 2000 ft, derate by 4% for each 1000 ft above sea level.

*For Canadian installations, ratings for altitudes to 2000 ft. High altitude units (2001-4500 ft) are derated by 10% of maximum input.

**Gas connection for propane is 1/2" for all sizes. Sizes shown are for gas connection to a single-stage gas valve; NOT gas supply line size.

***Additional mounting heights shown later in this catalog.

****All other information in this table is based on a heater equipped with a standard 115v motor. (The standard motor for a Model 25 is an enclosed motor; all other standard motors are open motors. Optional enclosed motors are available in 115v only.)

Required Clearances (inches)

Size	Top * Connector	Flue	Sides	Bottom **	Rear ***
25-125	2	6	18	12	24
165-400	6	6	18	12	24

*Measure top clearance as illustrated →

**When supplied with optional downturn nozzle, bottom clearance is 42". For service purposes on standard units, bottom clearance exceeding 12" minimum is not required but may be desirable.

***For service purposes only, rear must have 24" clearance.

DIMENSIONS + or - 1/8" (3mm)

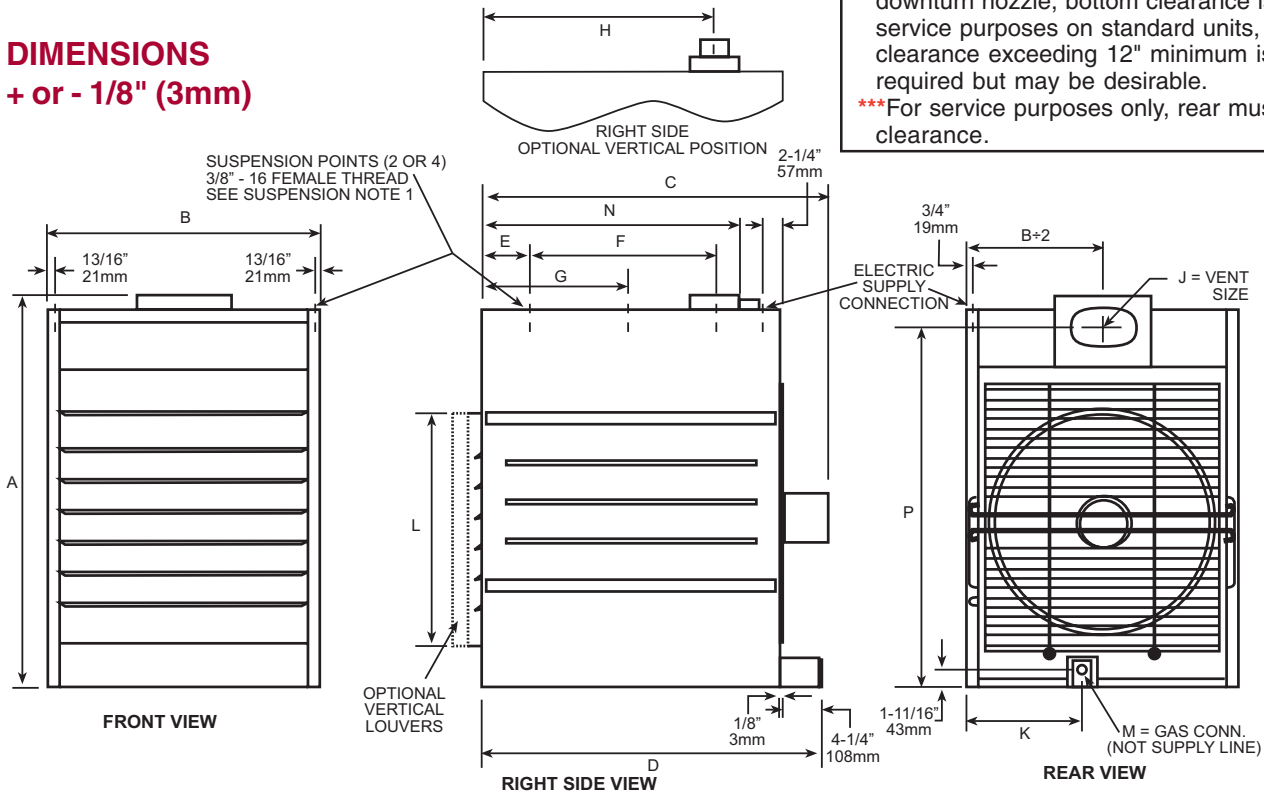

SUSPENSION NOTES:

- 1) Use dimension "G" for 2-point suspension and "E" and "F" for 4-point suspension.
- 2) Factory equipped with 2-point suspension; 4-point is optional.

Size	A		B		C		D		E		F		G		H		J		K		L		M		N		P		
	in	mm	in	mm	in	mm	in	mm	in	mm	in	mm	in	mm	in	mm	in	mm	in	mm	in	mm	Nat	Pro	in	mm	in	mm	
25,50	30 1/8	(765)	13 1/2	(343)	27	(686)	31 1/2	(800)	5 7/8	(149)	14 1/2	(368)	14	(356)	19	(483)	4 Round	10 1/4	(260)	16	(406)	1/2	1/2	21 1/2	(546)	27 5/8	(702)		
75	30 1/8	(765)	15 1/2	(394)	27	(686)	31 1/2	(800)	5 7/8	(149)	14 1/2	(368)	14	(356)	19	(483)	5 Oval	10 1/2	(267)	16	(406)	1/2	1/2	21 1/2	(546)	27 5/8	(702)		
100	30 1/8	(765)	17 1/2	(445)	30 1/2	(775)	31 1/2	(800)	5 7/8	(149)	14 1/2	(368)	14	(356)	19	(483)	6 Oval	12 7/8	(327)	16	(406)	1/2	1/2	21 1/2	(546)	27 5/8	(702)		
125	32	(813)	23 1/4	(591)	30 1/2	(775)	31 1/2	(800)	5 7/8	(149)	14 1/2	(368)	14	(356)	19	(483)	7 Oval	14 1/2	(368)	16	(406)	1/2	1/2	21 1/2	(546)	28 1/2	(724)		
165	40 1/8	(1,019)	20 1/4	(514)	35 1/2	(902)	36	(914)	4 7/8	(124)	19 1/2	(495)	15 3/4	(400)	23 3/8	(594)	8 Oval	14 1/4	(362)	24	(610)	1/2	1/2	27	(686)	36 3/4	(933)		
200	40 1/8	(1,019)	23 1/4	(591)	36 1/4	(921)	36	(914)	4 7/8	(124)	19 1/2	(495)	15 3/4	(400)	23 3/8	(594)	8 Oval	14 3/8	(365)	24	(610)	1/2	1/2	27	(686)	36 3/4	(933)		
250	43 1/2	(1,105)	28 3/4	(730)	36 1/4	(921)	36	(914)	4 7/8	(124)	19 1/2	(495)	15 3/4	(400)	21 3/4	(552)	10 Oval	12 3/8	(314)	24	(610)	1/2	1/2	27	(686)	38 3/8	(975)		
300	43 1/2	(1,105)	28 3/4	(730)	36 3/4	(933)	36	(914)	4 7/8	(124)	19 1/2	(495)	15 3/4	(400)	21 3/4	(552)	10 Oval	12 3/8	(314)	24	(610)	3/4	1/2	27	(686)	38 3/8	(975)		
400	43 1/2	(1,105)	37	(940)	37 1/4	(946)	36	(914)	4 7/8	(124)	19 1/2	(495)	15 3/4	(400)	21 3/4	(552)	12 Oval	13	(330)	24	(610)	3/4	1/2	27	(686)	38 3/8	(975)		

REZNOR®



ANSI Z83.8

CAN/CGA 2.6

DESCRIPTION

Reznor® Series 100, Model B gas-fired gravity-vented unit heaters are designed for 80% thermal efficiency and are designed for use with natural or propane gas, as specified, in sizes from 25,000 to 400,000 BTUH gas Input.

Model B unit heaters are designed for ceiling suspension with a centrifugal blower for air delivery. Sizes 25-100 are equipped with a direct drive blower motor with multi-speed taps capable of handling up to .50" w.c. of external static pressure. Sizes 125-400 are standardly equipped with a blower using an adjustable belt drive and motor capable of handling external static pressure up to .25" w.c. Optional motors and drives are available to increase the blower capability to handle up to .50" w.c. of external static pressure.

Standard features on the Model B Series units include a manual match-lit pilot with 100% shutoff and a single-stage, 24-volt gas valve. A terminal strip connector facilitates field connection to a remote 24-volt thermostat for automatic operation. Each unit is provided with a fan control and all required limit safety controls, including an energy cutoff (ECO) device and a blocked vent switch.

These units are approved for installation in The United States and Canada by the Canadian Standards Association (CSA). Canadian units require the selection of a totally enclosed motor. (An open motor may be selected for a heater to be installed in Canada only when the heater will be equipped with a Reznor® field-installed blower cabinet.)

NOTE: Model B units for California require the addition of spark pilot Option AH2 or AH3.

STANDARD FEATURES

- Orifices for natural gas
- Aluminized steel heat exchanger
- Aluminized steel burner rack with stainless steel insert
- Manual match-lit pilot with 100% shutoff
- Single-stage combination gas valve (field adjustable for high altitude operation)
- 115/1/60 supply voltage - Sizes 25-300
- 230/1/60 supply voltage - Size 400
- ODP motor with internal overload (U.S. installations)
- Totally enclosed blower motor (Canadian installations)
- Motor contactor - Sizes 300 and 400
- Direct drive blower with multi-speed taps - Sizes 25-100
- Adjustable belt drive blower - Sizes 125 - 400
- Fan and limit safety controls
- Blocked vent shutoff system
- Energy cutoff (ECO) device

NOTE: Regulated combination redundant gas valve consists of combination pilot solenoid valve, electric gas valve, pilot filter, pressure regulator, pilot shutoff, and manual shutoff, all in one body. Gas supply pressure must not exceed 0.5 psi (8 oz. or 14" w.c.). Minimum inlet pressure for natural gas is 5" w.c.; minimum inlet pressure for propane gas is 11" w.c.

Form RZ-NA-C-UH Page 22

MODEL B

GAS-FIRED, GRAVITY-VENTED, BLOWER-TYPE UNIT HEATER FOR COMMERCIAL/INDUSTRIAL USE

- 24-volt control voltage transformer
- Horizontal/Vertical vent outlet
- Horizontal louvers or Duct adapter
- Terminal strip connector for 24-volt field wiring
- Convenient bottom burner access
- 4-point 3/8"-16 threaded hanger connections

OPTIONAL FEATURES - Factory Installed

- Equipped for propane gas
- E-3 (409) stainless steel heat exchanger and burner
- Two-stage gas control (50% low fire) - Sizes 75-400
- Spark ignited, intermittent safety pilot with electronic flame supervision and with or without timed lockout (timed lockout is required for propane gas)
- Burner air shutters
- 208/230 single phase supply voltage - Sizes 125-400
- 208/230 three phase supply voltage - Sizes 125-400
- 460 three phase supply voltage - Sizes 125-400
- 575 three phase supply voltage - Sizes 125-400
- Alternate motor HP and drive - Sizes 50-400
- Totally enclosed blower motor

OPTIONS/ACCESSORIES - Field Installed

- | | |
|--|---|
| <ul style="list-style-type: none"> ● Power venter ● Vertical louvers ● Downturn air nozzle, 25-65° or 50-90° variable air deflector range ● Thermostat and relay kits ● Air recirculation kits ● Manual summer/winter switch ● Filter cabinet with 1" or 2" filters ● Polytube adapter - Models 75-400 ● Multiple heater control ● Hanger kits to suspend from 1" pipe or to use with vibration isolation suspension ● Unit-mounted thermostat bracket ● Step down transformer 230/115 or 460/115 - Sizes 25-100 | <ul style="list-style-type: none"> ● Burner air shutters ● Low ambient fan control relay kit ● Belt guard and/or blower inlet guard ● Single-stage and two-stage thermostats ● Thermostat guard with locking cover ● Manual shutoff valve and union ● Gas conversion kit |
|--|---|

NOTE: Not certified for residential use.

WARNING: Gas-fired appliances are not designed for use in hazardous atmospheres containing flammable vapors or combustible dust, or atmospheres containing chlorinated or halogenated hydrocarbons.

Installations in public garages or airplane hangars are permitted when in accordance with ANSI Z223.1 and NFPA 54 Codes or CAN1-B149 Codes and enforcing authorities.

TECHNICAL DATA - Model B

Size	25	50	75	100	125	165	200	250	300	400
Heating Input - BTUH (kW)	25,000 (7.3)	50,000 (14.7)	75,000 (22.0)	100,000 (29.3)	125,000 (36.6)	165,000 (48.4)	200,000 (58.6)	250,000 (73.3)	300,000 (87.9)	400,000 (117.2)
BTUH Thermal Output (80%)*	20,000 (5.9)	40,000 (11.7)	60,000 (17.6)	80,000 (23.4)	100,000 (29.3)	132,000 (38.7)	160,000 (46.9)	200,000 (58.6)	240,000 (70.3)	320,000 (93.8)
Vent Outlet Diameter	4" Rd	4" Rd	5" Oval	6" Oval	7" Oval	8" Oval	8" Oval	10" Oval	10" Oval	12" Oval
Gas Connection - Natural Gas**	1/2"	1/2"	1/2"	1/2"	1/2"	1/2"	1/2"	1/2"	3/4"	3/4"
Control Amps (24-volt)	0.33	0.33	0.33	0.33	0.33	0.23	0.23	0.23	0.2	0.2
Full-Load Amps (115 volt)	2.9	2.9	5.3	5.3	6	9	9	11	13	230V-9.1
Normal Consumption (watts) (60°F rise and .25" w.c. ESP)	140	175	340	430	500	710	750	1000	1320	1650
Maximum Air Volume - CFM (M ³ /hr)***	410 (697)	820 (1,393)	1,230 (2,090)	1,645 (2,795)	2,055 (3,491)	2,715 (4,613)	3,290 (5,590)	4,115 (6,991)	4,935 (8,384)	6,500 (11,043)
Minimum Air Volume - CFM (M ³ /hr)***	245 (416)	490 (832)	740 (1,257)	985 (1,673)	1,235 (2,098)	1,625 (2,761)	1,975 (3,355)	2,465 (4,188)	2,960 (5,029)	3,900 (6,626)
Standard Motor Horsepower	1/6	1/6	1/3	1/3	1/3	1/2	1/2	3/4	1	1 1/2
Blower Size (inches)	9x6	9x6	9x6	9x9	10x10	12x9	15x11	15x11	15x11	15x15
Approximate Net Wt - lbs (kg)	93 (42)	100 (45)	114 (52)	126 (57)	176 (80)	201 (91)	235 (107)	273 (124)	296 (134)	390 (177)
Approximate Shipping Wt - lbs (kg)	193 (88)	206 (93)	229 (104)	241 (109)	318 (144)	343 (156)	385 (175)	431 (196)	454 (206)	561 (254)

*For U.S. installations, ratings for altitudes to 2000 ft. Above 2000 ft, derate by 4% for each 1000 ft above sea level.

*For Canadian installations, ratings for altitudes to 2000 ft. High altitude units (2001-4500 ft) are derated by 10% of maximum input.

**Gas connection for propane is 1/2" for all sizes. Sizes shown are for gas connection to a single-stage gas valve; NOT gas supply line size.

***See Blower Chart and Blower Curve Section.

Filters for Optional Blower Cabinet

Model	Qty	*Filter Size
25-125	1	20x20
165-200	1	16x25
250-300	2	16x20
400	2	16x25
400	2	20x25

*1" or 2" permanent filters

Required Clearances

Top & Flue Connector	6"
Sides	18"
Bottom	12"
(when supplied with optional downturn nozzle, bottom clearance is 42"). For service purposes, in standard units, bottom clearance exceeding 12" minimum is not required, but may be desirable.	
Rear	24"
For service purposes the back of the unit must have 24" clearance.	

DIMENSIONS

+ or - 1/8" (3mm)

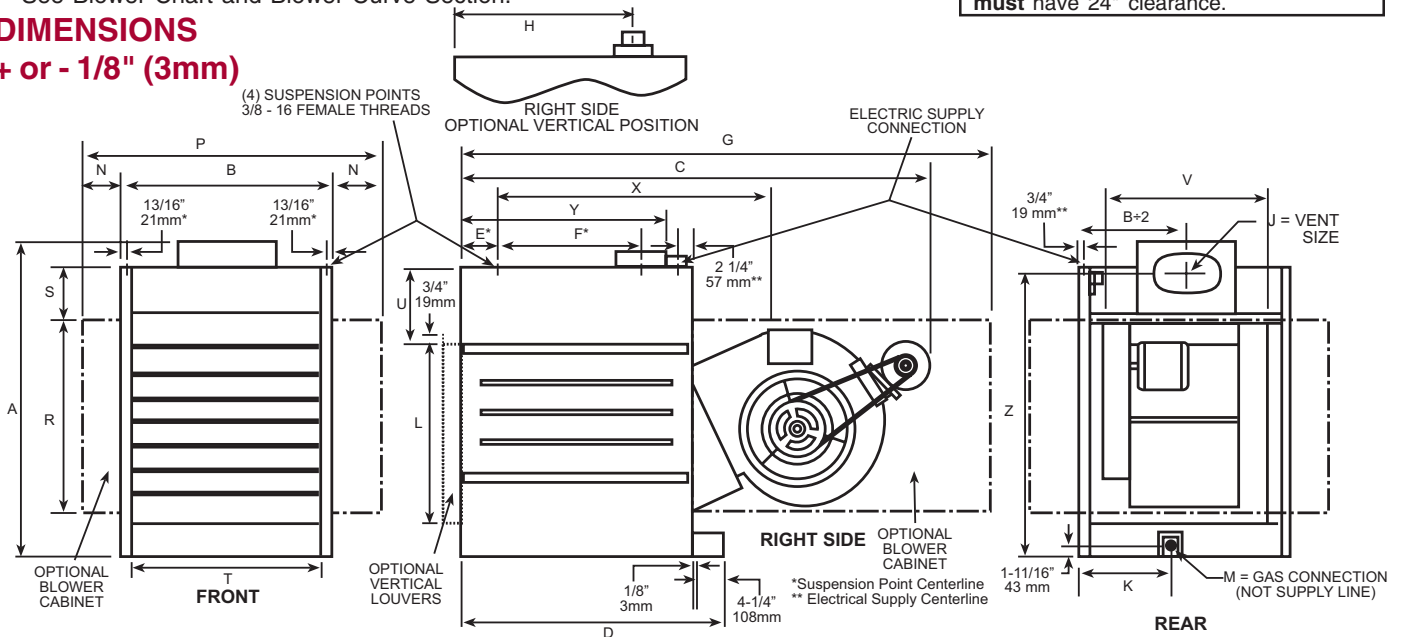

Size		A	B	C ⁸	D	E	F ⁴	G ³	H	J	K	L ^{1,2}	M		N ¹	P ¹	R ¹	S ¹	T ²	U ²	V ¹	W ¹	X ⁵	Y	Z
													Nat	Pro											
25	in	30 1/8	13 1/2	43 1/2	31 1/2	5 7/8	14 1/2	61 1/2	19	4 Rnd	10 1/4	15 7/8	1/2	1/2	3 3/4	21	17 3/4	5 1/4	10 3/4	8 1/2	14 3/4	6 1/4	31 1/4	21 1/2	27 5/8
	mm	(765)	(343)	(1,105)	(800)	(149)	(368)	(1,562)	(483)	--	(260)	(403)	--	--	(95)	(533)	(451)	(133)	(273)	(216)	(375)	(159)	(794)	(546)	(702)
50	in	30 1/8	13 1/2	50	31 1/2	5 7/8	14 1/2	61 1/2	19	4 Rnd	10 1/4	15 7/8	1/2	1/2	3 3/4	21	17 3/4	5 1/4	10 3/4	8 1/2	14 3/4	6 1/4	31 1/4	21 1/2	27 5/8
	mm	(765)	(343)	(1,270)	(800)	(149)	(368)	(1,562)	(483)	--	(260)	(403)	--	--	(95)	(533)	(451)	(133)	(273)	(216)	(375)	(159)	(794)	(546)	(702)
75	in	30 1/8	15 1/2	50	31 1/2	5 7/8	14 1/2	61 1/2	19	5 Oval	10 1/2	15 7/8	1/2	1/2	2 3/4	21	17 3/4	5 1/4	12 3/4	8 1/2	14 3/4	6 1/4	31 1/4	21 1/2	27 5/8
	mm	(765)	(394)	(1,270)	(800)	(149)	(368)	(1,562)	(483)	--	(267)	(403)	--	--	(70)	(533)	(451)	(133)	(324)	(216)	(375)	(159)	(794)	(546)	(702)
100	in	30 1/8	17 1/2	50	31 1/2	5 7/8	14 1/2	61 1/2	19	6 Oval	12 7/8	15 7/8	1/2	1/2	1 3/4	21	17 3/4	5 1/4	14 3/4	8 1/2	14 3/4	6 1/4	31 1/4	21 1/2	27 5/8
	mm	(765)	(445)	(1,270)	(800)	(149)	(368)	(1,562)	(483)	--	(327)	(403)	--	--	(44)	(533)	(451)	(133)	(375)	(216)	(375)	(159)	(794)	(546)	(702)
125	in	40 1/8	20 1/4	61	36	4 7/8	19 1/2	76 1/8	23 3/8	8 Oval	14 1/4	23 7/8	1/2	1/2	2 7/8	26	25 1/4	7 1/4	17 1/2	11 1/2	20 1/2	8	36 3/4	27	36 3/4
	mm	(1,019)	(514)	(1,549)	(914)	(124)	(495)	(1,934)	(594)	--	(362)	(606)	--	--	(73)	(660)	(641)	(184)	(445)	(292)	(521)	(203)	(933)	(686)	(933)
165	in	40 1/8	23 1/4	66 1/2	36	4 7/8	19 1/2	76 1/8	23 3/8	8 Oval	14 3/8	23 7/8	1/2	1/2	1 3/8	26	25 1/4	7 1/4	20 1/2	11 1/2	20 1/2	8	36 3/4	27	36 3/4
	mm	(1,019)	(591)	(1,689)	(914)	(124)	(495)	(1,934)	(594)	--	(365)	(606)	--	--	(35)	(660)	(641)	(184)	(445)	(292)	(521)	(203)	(933)	(686)	(933)
200	in	43 1/2	28 3/4	66 1/2	36	4 7/8	19 1/2	76 1/8	21 7/8	10 Oval	12 3/8	23 7/8	1/2	1/2	5 7/8	40 1/2	25 1/4	7 1/4	26	11 1/2	26	8	36 3/4	27	38 3/8
	mm	(1,105)	(730)	(1,689)	(914)	(124)	(495)	(1,934)	(556)	--	(314)	(606)	--	--	(149)	(1,029)	(641)	(184)	(660)	(292)	(660)	(203)	(933)	(686)	(975)
250	in	43 1/2	28 3/4	66 1/2	36	4 7/8	19 1/2	76 1/8	21 7/8	10 Oval	12 3/8	23 7/8	3/4	1/2	5 7/8	40 1/2	25 1/4	7 1/4	26	11 1/2	26	8	36 3/4	27	38 3/8
	mm	(1,105)	(730)	(1,689)	(914)	(124)	(495)	(1,934)	(556)	--	(314)	(606)	--	--	(149)	(1,029)	(641)	(184)	(660)	(292)	(660)	(203)	(933)	(686)	(975)
300	in	43 1/2	37	66 1/2	36	4 7/8	19 1/2	76 1/8	21 7/8	12 Oval	13	23 7/8	3/4	1/2	6 3/4	50 1/2	25 1/4	7 1/4	34 1/4	11 1/2	34 1/4	8	36 3/4	27	38 3/8
	mm	(1,105)	(940)	(1,689)	(914)	(124)	(495)	(1,934)	(556)	--	(330)	(606)	--	--	(171)	(1,283)	(641)	(184)	(870)	(292)	(870)	(203)	(933)	(686)	(975)

NOTES: 1) When equipped with optional blower cabinet. 2) When equipped with optional duct flange. 3) Dimension includes a 3/4" flange on rear of blower cabinet. 4) Use with 4-point suspension without blower cabinet. 5) Use with 4-point suspension with blower cabinet. 6) Contactor is standard on Models 300 & 400. 7) Contactor location with optional 3 phase motors on Models 50, 75, 100 & 125. 8) Deduct 6-5/8" on Models 50, 75 & 100 when equipped with direct drive motor.



DESCRIPTION

The Model OH/OB Series oil-fired unit heaters are available in inputs of 118,000, 173,000, and 229,000 BTUH with 82% efficiency output. These completely packaged unit heaters burn No. 2 fuel oil.

Model OH heaters are equipped with a propeller fan. The fan is enclosed in an OSHA-type full safety fan guard.

Model OB heaters are equipped with a centrifugal blower. The blower has an adjustable belt drive and is capable of handling external pressure of .25" w.c. Blower models are equipped with a belt guard and a blower inlet guard.

All units feature a low-stress, 18-gauge steel exchanger and a heavy, 13-gauge combustion chamber with large, easily accessible, service panels. The oil burner assembly has a pressure-atomizing gun type burner that provides excellent flame retention and an integral fuel pump. The burner has an electric spark ignition system with an electronic cad-cell flame safety system with manual reset. All models have a flame observation port.

Standard features include fan and limit controls. The fan control prevents circulation of cold air at start-up and provides heat dissipation while the unit is hot after the burner shuts off. The safety limit control provides unit protection from high temperature caused by an airflow restriction or motor failure. All units are wired for 115 volt, 60 Hz power supply and can be controlled with a 24V thermostat.

Model OH/OB oil-fired unit heaters are approved for installation in The United States and Canada by the Canadian Standards Association (CSA).

NOTE: Not certified for residential use.

STANDARD FEATURES

- Full automatic, thermostatically controlled operation
- Low stress, 18-gauge steel heat exchanger
- Heavy, 13-gauge steel combustion chamber
- 115/1/60 supply voltage
- 24-volt control voltage
- Atomizing power burner with single-stage fuel pump
- Electric spark ignition with cad-cell flame safety system
- Fan and limit safety controls
- Toggle disconnect switch
- Propeller fan - OH Models
Centrifugal blower with adjustable belt drive - OB Models
- Full safety fan guard - OH Models
Belt guard and blower inlet guard - OB Models
- Totally enclosed, permanently lubricated PSC motor with internal overload protection - OH Models
Total enclosed, permanently lubricated split-phase motor with internal overload protection - OB Models
- Built-in burner service tray
- Large easily accessible service panels for combustion chamber and heat exchanger maintenance
- Observation port
- Individually adjustable horizontal louvers
- 4-point suspension (1/2" threaded connectors)
- Draft regulator - CSA Models

OPTIONAL FEATURES - Field Installed

- Vertical louvers
- Atomizing burner with two-stage fuel pump
- 30 GPH booster pump assembly with motor and two-stage fuel pump
- 70 GPH booster pump assembly with motor and two-stage fuel pump
- Booster pump pressure switch - used for intermittent pump operation in pressurized system
- Oil safety valve - recommended for all systems -- prevents siphoning and over pressure
- Draft Regulator - UL listed model
- Draft inducer relay
- Hanger kit to suspend from 1" pipe
- Outside combustion air adapter (not available with CSA models)
- Thermostat, single stage, 24-volt (40-90°F)
- Thermostat guard with locking cover

A UL Listed (or equivalent) oil supply tank must be used with Reznor® oil-fired heaters.

Model OT-250 fuel tank is available from Reznor.

● UL Listed

● 250-gallon capacity

● Bench top

For additional information, refer to Options and Accessories Section.

TECHNICAL DATA - Models OH and OB

Size	OH95		OB95		OH140		OB140		OH190		OB190	
Thermal Input - BTUH (kW)	118,000	(34.6)	118,000	(34.6)	173,000	(50.7)	173,000	(50.7)	229,000	(67.1)	229,000	(67.1)
Thermal Output - BTUH (kW)	97,000	(28.4)	97,000	(28.4)	142,000	(41.6)	142,000	(41.6)	188,000	(55.1)	188,000	(55.1)
Nozzle Input - GPH (l/hr)	0.85	(3.22)	0.85	(3.22)	1.25	(4.73)	1.25	(4.73)	1.65	(6.25)	1.65	(6.25)
Full-Load Amps (115 volt)	6		11		7		11		7		16	
Fan Motor RPM	1,050		--		850		--		850		--	
Blower Motor RPM	--		1,725		--		1,725		--		1,725	
Motor HP	1/8		1/2		1/4		1/4		1/4		3/4	
Air Volume (Free Air) - CFM (M ³ /hr)	2,000	(3,398)	2,000	(3,398)	3,200	(5,437)	3,200	(5,437)	3,200	(5,437)	3,200	(5,437)
Air Volume @ .25" ESP - CFM (M ³ /hr)	--		1,450	(2,463)	--		2,140	(3,636)	--		2,140	(3,636)
Throw at 9' (3M) Mntg Ht - ft (M)	50	(15)	50	(15)	65	(20)	65	(20)	65	(20)	65	(20)
Flue Diameter - inches	7		7		8		8		8		8	
Blower Size - inches	--		12-5/8 x 9-1/2		--		15 x 11-1/8		--		15 x 11-1/8	
Fan Diameter (inches) and Pitch (°)	18 - 33		--		22 - 36		--		22 - 36		--	
Approximate Net Wt (lbs)	290	(132)	355	(161)	345	(156)	410	(186)	345	(156)	410	(186)
Approximate Shipping Wt	340	(154)	420	(191)	405	(184)	495	(225)	405	(184)	495	(225)

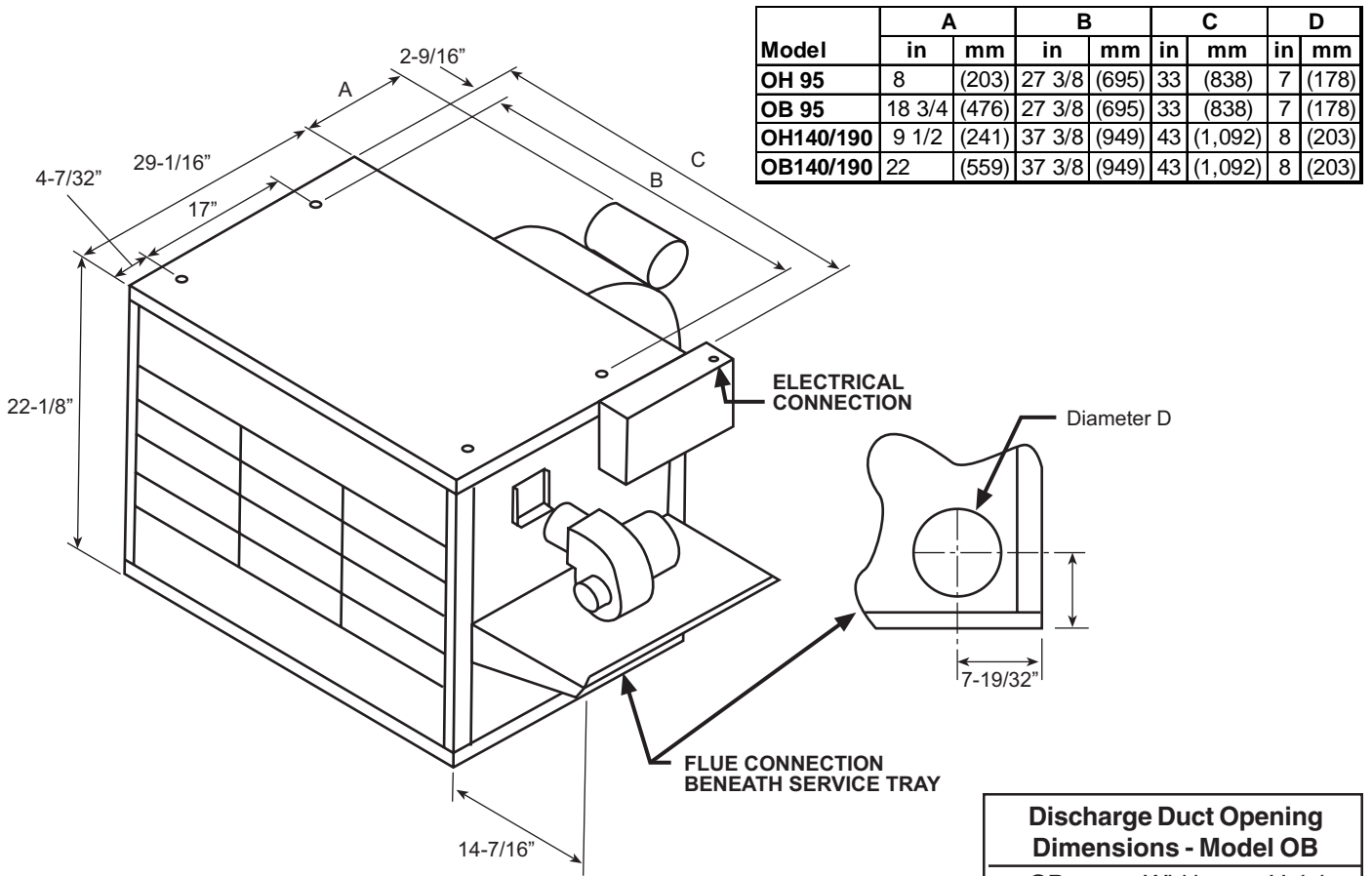

Draft Regulator Requirement - ALL Model OH/OB installations require a draft regulator (barometric draft control device) in the vent.

- Model OH/OB with a CSA Label** - A draft regulator is factory-supplied and must be installed.
- Model OH/OB with a UL Label** - a Factory-supplied draft regulator is available as an option (Option BV2 or DB1). Either the optional draft regulator or a field supplied, UL-approved draft regulator must be installed.

CLEARANCE: An 18" clearance is required from the top of the draft control to a combustible ceiling.

Required Clearances

	OH	OB
Top	2"	6"
Front	48"	48"
Burner Side (for service)	18"	18"
Side Opposite Burner (for service)	18"	18"
Rear	24"	6"
Bottom	6"	6"
Flue pipe - units with UL label	18"	18"
Flue pipe - units with CSA label	9"	9"



Throw/Floor Coverage at Various Mounting Heights

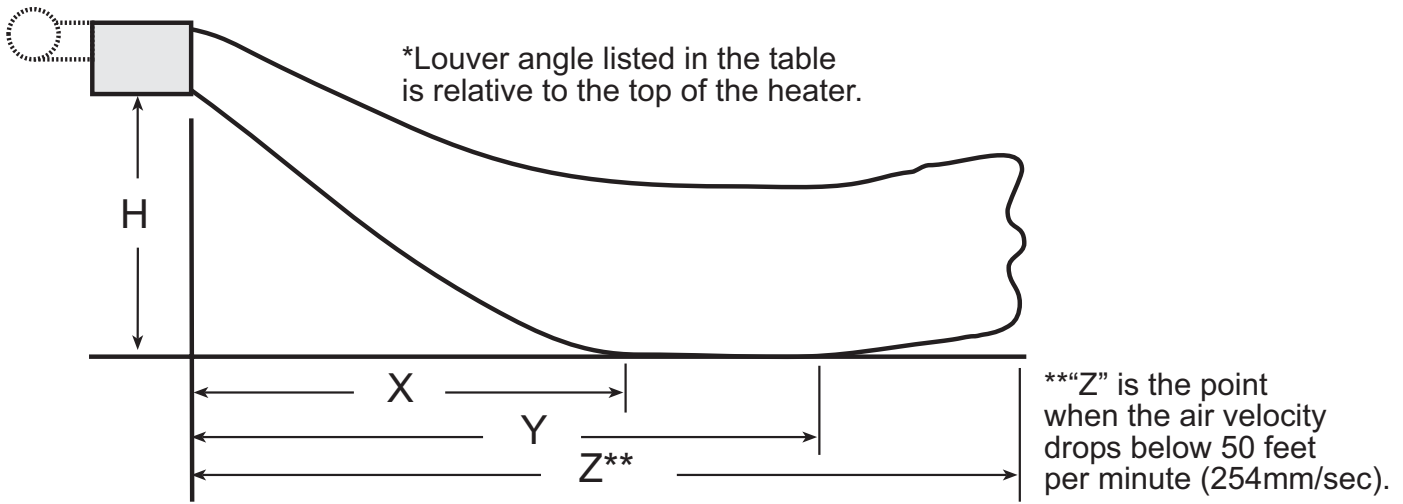

Applies to both Model UDAS and Model UDAP

Dimensions given in feet.

Size Mounting Height	30				45				60				75				100				125				150			
	X	Y	Z	Louver Angle	X	Y	Z	Louver Angle	X	Y	Z	Louver Angle	X	Y	Z	Louver Angle	X	Y	Z	Louver Angle	X	Y	Z	Louver Angle	X	Y	Z	Louver Angle
5	6	14	30	-21°	7	16	40	-20°	8	18	45	-16°	9	20	57	-14°	9	20	59	-18°	10	22	65	-14°	--	--	--	--
8	7	13	26	-39°	9	16	37	-34°	10	18	42	-29°	12	22	54	-25°	11	21	56	-28°	12	23	63	-24°	13	24	73	-26°
10	6	11	22	-52°	9	15	33	-43°	10	17	39	-37°	12	22	52	-32°	12	20	52	-36°	13	24	60	-30°	14	24	69	-32°
12	--	--	--	--	8	12	27	-55°	10	16	34	-46°	12	21	48	-39°	11	19	47	-44°	14	23	57	-36°	14	24	64	-39°
14	--	--	--	--	--	--	--	--	9	14	29	-56°	12	19	44	-46°	11	17	42	-51°	14	22	53	-43°	14	22	59	-45°
16	--	--	--	--	--	--	--	--	--	--	--	--	11	17	38	-54°	10	14	34	-58°	13	20	47	-50°	13	20	53	-51°
18	--	--	--	--	--	--	--	--	--	--	--	--	--	--	--	--	--	--	--	--	11	17	40	-57°	11	17	44	-58°

Size Mounting Height	175				200				225				250				300				350				400						
	X	Y	Z	Louver Angle	X	Y	Z	Louver Angle	X	Y	Z	Louver Angle	X	Y	Z	Louver Angle	X	Y	Z	Louver Angle	X	Y	Z	Louver Angle	X	Y	Z	Louver Angle	X	Y	Z
8	15	28	90	-22°	16	30	93	-20°	14	27	86	-24°	16	29	93	-21°	15	28	94	-24°	17	31	105	-20°	18	34	113	-17°			
10	17	29	87	-27°	17	31	91	-25°	15	27	82	-30°	17	30	90	-26°	16	28	89	-29°	18	32	103	-25°	20	35	110	-21°			
12	18	29	84	-32°	18	31	88	-30°	16	27	78	-35°	18	30	87	-31°	17	28	85	-34°	19	32	98	-30°	21	36	108	-25°			
14	18	28	79	-37°	19	30	84	-34°	16	26	73	-41°	18	30	83	-36°	17	27	80	-40°	20	32	95	-34°	23	35	105	-29°			
16	18	27	74	-42°	19	29	79	-39°	16	24	67	-47°	19	28	78	-41°	17	25	74	-45°	21	31	90	-38°	23	35	101	-33°			
18	17	26	68	-48°	19	28	74	-44°	14	22	60	-53°	18	27	72	-46°	16	24	66	-51°	20	30	85	-43°	23	35	97	-37°			

Dimensions given in meters.

Size Mounting Height	30				45				60				75				100				125				150						
	X	Y	Z	Louver Angle	X	Y	Z	Louver Angle	X	Y	Z	Louver Angle	X	Y	Z	Louver Angle	X	Y	Z	Louver Angle	X	Y	Z	Louver Angle	X	Y	Z	Louver Angle	X	Y	Z
1.5	1.8	4.3	9.1	-21°	2.1	4.9	12.2	-20°	2.4	5.5	13.7	-16°	2.7	6.1	17.4	-14°	2.7	6.1	18.0	-18°	3.0	6.7	19.8	-14°	--	--	--	--			
2.4	2.1	4.0	7.9	-39°	2.7	4.9	11.3	-34°	3.0	5.5	12.8	-29°	3.7	6.7	16.5	-25°	3.4	6.4	17.1	-28°	3.7	7.0	19.2	-24°	4.0	7.3	22.3	-26°			
3.0	1.8	3.4	6.7	-52°	2.7	4.6	10.1	-43°	3.0	5.2	11.9	-37°	3.7	6.7	15.8	-32°	3.7	6.1	15.8	-36°	4.0	7.3	18.3	-30°	4.3	7.3	21.0	-32°			
3.7	--	--	--	--	2.4	3.7	8.2	-55°	3.0	4.9	10.4	-46°	3.7	6.4	14.6	-39°	3.4	5.8	14.3	-44°	4.3	7.0	17.4	-36°	4.3	7.3	19.5	-39°			
4.3	--	--	--	--	--	--	--	--	2.7	4.3	8.8	-56°	3.7	5.8	13.4	-46°	3.4	5.2	12.8	-51°	4.3	6.7	16.2	-43°	4.3	6.7	18.0	-45°			
4.9	--	--	--	--	--	--	--	--	--	--	--	--	3.4	5.2	11.6	-54°	3.0	4.3	10.4	-58°	4.0	6.1	14.3	-50°	4.0	6.1	16.2	-51°			
5.5	--	--	--	--	--	--	--	--	--	--	--	--	--	--	--	--	--	--	--	--	3.4	5.2	12.2	-57°	3.4	5.2	13.4	-58°			

Size Mounting Height	175				200				225				250				300				350				400						
	X	Y	Z	Louver Angle	X	Y	Z	Louver Angle	X	Y	Z	Louver Angle	X	Y	Z	Louver Angle	X	Y	Z	Louver Angle	X	Y	Z	Louver Angle	X	Y	Z	Louver Angle	X	Y	Z
2.4	4.6	8.5	27.4	-22°	4.9	9.1	28.3	-20°	4.3	8.2	26.2	-24°	4.9	8.8	28.3	-21°	4.6	8.5	28.7	-24°	5.2	9.4	32.0	-20°	5.5	10.4	34.4	-17°			
3.0	5.2	8.8	26.5	-27°	5.2	9.4	27.7	-25°	4.6	8.2	25.0	-30°	5.2	9.1	27.4	-26°	4.9	8.5	27.1	-29°	5.5	9.8	31.4	-25°	6.1	10.7	33.5	-21°			
3.7	5.5	8.8	25.6	-32°	5.5	9.4	26.8	-30°	4.9	8.2	23.8	-35°	5.5	9.1	26.5	-31°	5.2	8.5	25.9	-34°	5.8	9.8	29.9	-30°	6.4	11.0	32.9	-25°			
4.3	5.5	8.5	24.1	-37°	5.8	9.1	25.6	-34°	4.9	7.9	22.3	-41°	5.5	9.1	25.3	-36°	5.2	8.2	24.4	-40°	6.1	9.8	29.0	-34°	7.0	10.7	32.0	-29°			
4.9	5.5	8.2	22.6	-42°	5.8	8.8	24.1	-39°	4.9	7.3	20.4	-47°	5.8	8.5	23.8	-41°	5.2	7.6	22.6	-45°	6.4	9.4	27.4	-38°	7.0	10.7	30.8	-33°			
5.5	5.2	7.9	20.7	-48°	5.8	8.5	22.6	-44°	4.3	6.7	18.3	-53°	5.5	8.2	21.9	-46°	4.9	7.3	20.1	-51°	6.1	9.1	25.9	-43°	7.0	10.7	29.6	-37°			



Throw/Floor Coverage at Various Mounting Heights (cont'd)

Applies to both Model UDBS and Model UDBP

See illustration on previous page.

Dimensions given in feet.

Size Mounting Height	Low Speed																75°F Rise											
	30				45				60				75				100				125				150			
	X	Y	Z	Louver Angle	X	Y	Z	Louver Angle	X	Y	Z	Louver Angle	X	Y	Z	Louver Angle	X	Y	Z	Louver Angle	X	Y	Z	Louver Angle	X	Y	Z	Louver Angle
5	7	15	38	-27°	7	17	44	-20°	11	26	78	-15°	11	24	74	-13°	10	23	74	-16°	10	22	69	-14°	--	--	--	--
8	7	13	32	-44°	9	17	40	-34°	14	26	76	-23°	13	26	72	-23°	13	25	72	-25°	12	24	65	-24°	9	16	44	-39°
10	7	11	25	-56°	9	16	37	-42°	15	27	72	-29°	15	25	69	-28°	14	25	69	-31°	13	24	62	-31°	9	14	38	-48°
12	--	--	--	--	9	14	31	-52°	16	26	70	-34°	15	25	65	-34°	14	24	66	-37°	14	23	58	-37°	7	11	30	-58°
14	--	--	--	--	--	--	--	--	16	25	65	-40°	15	24	62	-40°	14	23	62	-43°	14	21	54	-43°	--	--	--	--
16	--	--	--	--	--	--	--	--	15	24	60	-46°	15	23	56	-46°	14	21	57	-49°	12	19	47	-51°	--	--	--	--
18	--	--	--	--	--	--	--	--	14	22	53	-52°	14	21	50	-52°	12	18	51	-56°	11	17	40	-57°	--	--	--	--

Size Mounting Height	Medium Speed																60°F Rise											
	30				45				60				75				100				125				150			
	X	Y	Z	Louver Angle	X	Y	Z	Louver Angle	X	Y	Z	Louver Angle	X	Y	Z	Louver Angle	X	Y	Z	Louver Angle	X	Y	Z	Louver Angle	X	Y	Z	Louver Angle
5	7	16	43	-24°	9	21	60	-15°	12	28	91	-13°	11	27	84	-11°	11	27	86	-13°	12	29	96	-10°	--	--	--	--
8	9	16	38	-38°	11	23	57	-26°	16	30	89	-21°	15	29	82	-19°	15	28	83	-21°	16	31	94	-18°	13	24	74	-28°
10	8	14	33	-48°	13	22	54	-32°	17	30	86	-26°	16	30	79	-25°	17	29	81	-26°	18	32	92	-23°	13	22	62	-35°
12	8	12	28	-56°	13	21	51	-39°	18	31	83	-31°	17	30	77	-30°	17	29	78	-32°	19	32	89	-27°	13	21	57	-42°
14	--	--	--	--	12	20	46	-46°	18	30	79	-36°	18	29	74	-34°	18	29	74	-37°	20	32	87	-32°	12	19	51	-49°
16	--	--	--	--	11	17	40	-53°	19	29	75	-41°	18	28	70	-39°	18	27	70	-42°	20	31	83	-36°	11	16	43	-57°
18	--	--	--	--	--	--	--	--	17	28	69	-46°	18	26	65	-44°	17	26	64	-47°	20	30	78	-40°	--	--	--	--

Size Mounting Height	High Speed																45°F Rise											
	30				45				60				75				100				125				150			
	X	Y	Z	Louver Angle	X	Y	Z	Louver Angle	X	Y	Z	Louver Angle	X	Y	Z	Louver Angle	X	Y	Z	Louver Angle	X	Y	Z	Louver Angle	X	Y	Z	Louver Angle
5	8	19	51	-20°	11	28	81	-11°	13	30	105	-11°	12	30	97	-09°	13	32	110	-10°	13	33	113	-7°	--	--	--	--
8	10	19	48	-31°	15	29	79	-19°	17	33	103	-19°	17	33	95	-16°	18	34	108	-17°	19	36	111	-13°	18	32	107	-19°
10	11	19	44	-39°	16	30	78	-24°	19	34	100	-23°	19	33	94	-20°	20	36	106	-21°	21	37	109	-17°	19	34	104	-24°
12	11	17	40	-46°	17	30	75	-29°	21	35	98	-27°	20	34	92	-25°	22	36	104	-25°	23	39	107	-21°	21	34	102	-28°
14	9	15	33	-56°	18	30	72	-34°	22	34	95	-31°	21	34	89	-29°	23	36	102	-29°	24	39	105	-25°	22	34	98	-32°
16	--	--	--	--	19	29	69	-39°	23	33	91	-35°	22	33	86	-33°	24	36	99	-33°	25	40	103	-29°	22	33	94	-36°
18	--	--	--	--	18	28	64	-44°	21	33	86	-40°	22	33	83	-37°	23	36	95	-37°	26	39	101	-32°	21	33	89	-41°

Size Mounting Height	75°F Rise																80°F Rise											
	175				200				225				250				300				350				400			
	X	Y	Z	Louver Angle	X	Y	Z	Louver Angle	X	Y	Z	Louver Angle	X	Y	Z	Louver Angle	X	Y	Z	Louver Angle	X	Y	Z	Louver Angle	X	Y	Z	Louver Angle
8	12	22	69	-30°	13	24	76	-27°	13	24	82	-29°	14	27	95	-26°	12	21	70	-32°	13	25	82	-27°	15	28	95	-24°
10	12	22	65	-37°	14	24	72	-33°	12	21	66	-38°	16	27	91	-31°	12	21	65	-39°	14	25	77	-33°	16	28	92	-29°
12	13	21	59	-43°	14	23	68	-39°	12	20	60	-45°	16	27	86	-37°	12	19	58	-47°	14	24	72	-40°	17	28	88	-34°
14	11	19	52	-51°	14	22	62	-46°	11	18	53	-52°	16	25	80	-43°	10	17	50	-55°	14	22	66	-46°	17	27	82	-39°
16	--	--	--	--	12	20	53	-53°	--	--	--	--	16	23	73	-49°	--	--	--	--	13	20	57	-53°	17	26	76	-45°
18	--	--	--	--	--	--	--	--	--	--	--	--	14	21	64	-56°	--	--	--	--	--	--	--	--	16	24	69	-50°

Size Mounting Height	60°F Rise																70°F Rise											
	175				200				225				250				300				350				400			
	X	Y	Z	Louver Angle	X	Y	Z	Louver Angle	X	Y	Z	Louver Angle	X	Y	Z	Louver Angle	X	Y	Z	Louver Angle	X	Y	Z	Louver Angle	X	Y	Z	Louver Angle
8	15	29	92	-22°	16	31	100	-21°	16	29	100	-24°	19	34	127	-20°	16	28	100	-24°	18	33	119	-20°	17	31	111	-21°
10	16	29	89	-28°	18	31	97	-25°	16	30	96	-29°	20	35	123	-24°	17	29	96	-29°	19	34	116	-25°	18	32	107	-26°
12	17	29	85	-33°	19	31	93	-30°	17	30	92	-34°	21	36	120	-28°	18	29	92	-34°	21	34	113	-29°	19	32	103	-31°
14	17	28	80	-38°	20	30	89	-34°	18	28	87	-38°	22	35	116	-32°	18	28	87	-39°	22	34	109	-33°	20	31	99	-35°
16	17	27	75	-43°	20	29	84	-39°	18	27	80	-44°	23	35	111	-37°	18	27	81	-44°	22	33	104	-37°	20	31	93	-40°
18	17	25	69	-48°	19	29	79	-44°	17	26	74	-49°	23	34	106	-41°	17	25	73	-50°	22	32	98	-41°	20	29	88	-44°

Size Mounting Height	45°F Rise																50°F Rise											
	175				200				225				250				300				350				400			
	X	Y	Z	Louver Angle	X	Y	Z	Louver Angle	X	Y	Z	Louver Angle	X	Y	Z	Louver Angle	X	Y	Z	Louver Angle	X	Y	Z	Louver Angle	X	Y	Z	Louver Angle
8	22	41	146	-15°	23	43	157	-13°	23	43	168	-16°	26	48	198	-14°	21	39	146	-17°	24	45	169	-14°	24	44	169	-14°
10	24	43	144	-19°	25	46	155	-17°	26	45	166	-19°	29	50	196	-17°	23	41	143	-21°	26	47	167	-18°	26	46	167	-17°
12	26	43	141	-22°	27	47	152	-20°	28	45	163	-22°	31	52	194	-20°	25	42	140	-25°	28	48	165	-21°	28	48	165	-20°
14	28	44	137	-25°	29	48	150	-23°	30	46	160	-25°	32	54	191	-22°	26	42	137	-28°	30	49	162	-24°	31	48	162	-23°
16	29	44	134	-28°	31	48	147	-26°	31	47	157	-29°	34	53	189	-25°	27	42	133	-31°	32	48	159	-26°	32	49	159	-26°
18	29	44	131	-32°	31	49	144	-29°	31	47	153	-32°	34	54	185	-28°	28	41	129	-34°	33	49	156	-29°	32	49	156	-29°

Applies to both Model UDBS and Model UDBP

See illustration on page 26.

Dimensions given in meters.

Size Mounting Height	Low Speed																24°C Rise											
	30				45				60				75				100				125				150			
	X	Y	Z	Louver Angle	X	Y	Z	Louver Angle	X	Y	Z	Louver Angle	X	Y	Z	Louver Angle	X	Y	Z	Louver Angle	X	Y	Z	Louver Angle	X	Y	Z	Louver Angle
1.5	2.1	4.6	11.6	-27°	2.1	5.2	13.4	-20°	3.4	7.9	23.8	-15°	3.4	7.3	22.6	-13°	3.0	7.0	22.6	-16°	3.0	6.7	21.0	-14°	--	--	--	--
2.4	2.1	4.0	9.8	-44°	2.7	5.2	12.2	-34°	4.3	7.9	23.2	-23°	4.0	7.9	21.9	-23°	4.0	7.6	21.9	-25°	3.7	7.3	19.8	-24°	2.7	4.9	13.4	-39°
3.0	2.1	3.4	7.6	-56°	2.7	4.9	11.3	-42°	4.6	8.2	21.9	-29°	4.6	7.6	21.0	-28°	4.3	7.6	21.0	-31°	4.0	7.3	18.9	-31°	2.7	4.3	11.6	-48°
3.7	--	--	--	--	2.7	4.3	9.4	-52°	4.9	7.9	21.3	-34°	4.6	7.6	19.8	-34°	4.3	7.3	20.1	-37°	4.3	7.0	17.7	-37°	2.1	3.4	9.1	-58°
4.3	--	--	--	--	--	--	--	--	4.9	7.6	19.8	-40°	4.6	7.3	18.9	-40°	4.3	7.0	18.9	-43°	4.3	6.4	16.5	-43°	--	--	--	--
4.9	--	--	--	--	--	--	--	--	4.6	7.3	18.3	-46°	4.6	7.0	17.1	-46°	4.3	6.4	17.4	-49°	3.7	5.8	14.3	-51°	--	--	--	--
5.5	--	--	--	--	--	--	--	--	4.3	6.7	16.2	-52°	4.3	6.4	15.2	-52°	3.7	5.5	15.5	-56°	3.4	5.2	12.2	-57°	--	--	--	--

Size Mounting Height	Medium Speed																16°C Rise											
	30				45				60				75				100				125				150			
	X	Y	Z	Louver Angle	X	Y	Z	Louver Angle	X	Y	Z	Louver Angle	X	Y	Z	Louver Angle	X	Y	Z	Louver Angle	X	Y	Z	Louver Angle	X	Y	Z	Louver Angle
1.5	2.1	4.9	13.1	-24°	2.7	6.4	18.3	-15°	3.7	8.5	27.7	-13°	3.4	8.2	25.6	-11°	3.4	8.2	26.2	-13°	3.7	8.8	29.3	-10°	--	--	--	--
2.4	2.7	4.9	11.6	-38°	3.4	7.0	17.4	-26°	4.9	9.1	27.1	-21°	4.6	8.8	25.0	-19°	4.6	8.5	25.3	-21°	4.9	9.4	28.7	-18°	4.0	7.3	22.6	-28°
3.0	2.4	4.3	10.1	-48°	4.0	6.7	16.5	-32°	5.2	9.1	26.2	-26°	4.9	9.1	24.1	-25°	5.2	8.8	24.7	-26°	5.5	9.8	28.0	-23°	4.0	6.7	18.9	-35°
3.7	2.4	3.7	8.5	-56°	4.0	6.4	15.5	-39°	5.5	9.4	25.3	-31°	5.2	9.1	23.5	-30°	5.2	8.8	23.8	-32°	5.8	9.8	27.1	-27°	4.0	6.4	17.4	-42°
4.3	--	--	--	--	3.7	6.1	14.0	-46°	5.5	9.1	24.1	-36°	5.5	8.8	22.6	-34°	5.5	8.8	22.6	-37°	6.1	9.8	26.5	-32°	3.7	5.8	15.5	-49°
4.9	--	--	--	--	3.4	5.2	12.2	-53°	5.8	8.8	22.9	-41°	5.5	8.5	21.3	-39°	5.5	8.2	21.3	-42°	6.1	9.4	25.3	-36°	3.4	4.9	13.1	-57°
5.5	--	--	--	--	--	--	--	--	5.2	8.5	21.0	-46°	5.5	7.9	19.8	-44°	5.2	7.9	19.5	-47°	6.1	9.1	23.8	-40°	--	--	--	--

Size Mounting Height	High Speed																7°C Rise											
	30				45				60				75				100				125				150			
	X	Y	Z	Louver Angle	X	Y	Z	Louver Angle	X	Y	Z	Louver Angle	X	Y	Z	Louver Angle	X	Y	Z	Louver Angle	X	Y	Z	Louver Angle	X	Y	Z	Louver Angle
1.5	2.4	5.8	15.5	-20°	3.4	8.5	24.7	-11°	4.0	9.1	32.0	-11°	3.7	9.1	29.6	-09°	4.0	9.8	33.5	-10°	4.0	10.1	34.4	-7°	--	--	--	--
2.4	3.0	5.8	14.6	-31°	4.6	8.8	24.1	-19°	5.2	10.1	31.4	-19°	5.2	10.1	29.0	-16°	5.5	10.4	32.9	-17°	5.8	11.0	33.8	-13°	5.5	9.8	32.6	-19°
3.0	3.4	5.8	13.4	-39°	4.9	9.1	23.8	-24°	5.8	10.4	30.5	-23°	5.8	10.1	28.7	-20°	6.1	11.0	32.3	-21°	6.4	11.3	33.2	-17°	5.8	10.4	31.7	-24°
3.7	3.4	5.2	12.2	-46°	5.2	9.1	22.9	-29°	6.4	10.7	29.9	-27°	6.1	10.4	28.0	-25°	6.7	11.0	31.7	-25°	7.0	11.9	32.6	-21°	6.4	10.4	31.1	-28°
4.3	2.7	4.6	10.1	-56°	5.5	9.1	21.9	-34°	6.7	10.4	29.0	-31°	6.4	10.4	27.1	-29°	7.3	11.0	31.1	-29°	7.3	11.9	32.0	-25°	6.7	10.4	29.9	-32°
4.9	--	--	--	--	5.8	8.8	21.0	-39°	7.0	10.1	27.7	-35°	6.7	10.1	26.2	-33°	7.3	11.0	30.2	-33°	7.6	12.2	31.4	-29°	6.7	10.1	28.7	-36°
5.5	--	--	--	--	5.5	8.5	19.5	-44°	6.4	10.1	26.2	-40°	6.7	10.1	25.3	-37°	7.0	11.0	29.0	-37°	7.9	11.9	30.8	-32°	6.4	10.1	27.1	-41°

Size Mounting Height	24°C Rise																27°C Rise											
	175				200				225				250				300				350				400			
	X	Y	Z	Louver Angle	X	Y	Z	Louver Angle	X	Y	Z	Louver Angle	X	Y	Z	Louver Angle	X	Y	Z	Louver Angle	X	Y	Z	Louver Angle	X	Y	Z	Louver Angle
2.4	3.7	6.7	21.0	-30°	4.0	7.3	23.2	-27°	4.0	7.3	25.0	-29°	4.3	8.2	29.0	-26°	3.7	6.4	21.3	-32°	4.0	7.6	25.0	-27°	4.6	8.5	29.0	-24°
3.0	3.7	6.7	19.8	-37°	4.3	7.3	21.9	-33°	3.7	6.4	20.1	-38°	4.9	8.2	27.7	-31°	3.7	6.4	19.8	-39°	4.3	7.6	23.5	-33°	4.9	8.5	28.0	-29°
3.7	4.0	6.4	18.0	-43°	4.3	7.0	20.7	-39°	3.7	6.1	18.3	-45°	4.9	8.2	26.2	-37°	3.7	5.8	17.7	-47°	4.3	7.3	21.9	-40°	5.2	8.5	26.8	-34°
4.3	3.4	5.8	15.8	-51°	4.3	6.7	18.9	-46°	3.4	5.5	16.2	-52°	4.9	7.6	24.4	-33°	3.0	5.2	15.2	-55°	4.3	6.7	20.1	-46°	5.2	8.2	25.0	-39°
4.9	--	--	--	--	3.7	6.1	16.2	-53°	--	--	--	--	4.9	7.0	22.3	-49°	--	--	--	--	4.0	6.1	17.4	-53°	5.2	7.9	23.2	-45°
5.5	--	--	--	--	--	--	--	--	--	--	--	--	4.3	6.4	19.5	-56°	--	--	--	--	--	--	--	--	4.9	7.3	21.0	-50°

Size Mounting Height	16°C Rise																21°C Rise											
	175				200				225				250				300				350				400			
	X	Y	Z	Louver Angle	X	Y	Z	Louver Angle	X	Y	Z	Louver Angle	X	Y	Z	Louver Angle	X	Y	Z	Louver Angle	X	Y	Z	Louver Angle	X	Y	Z	Louver Angle
2.4	4.6	8.8	28.0	-22°	4.9	9.4	30.5	-21°	4.9	8.8	30.5	-24°	5.8	10.4	38.7	-20°	4.9	8.5	30.5	-24°	5.5	10.1	36.3	-20°	5.2	9.4	33.8	-21°
3.0	4.9	8.8	27.1	-28°	5.5	9.4	29.6	-25°	4.9	9.1	29.3	-29°	6.1	10.7	37.5	-24°	5.2	8.8	29.3	-29°	5.8	10.4	35.4	-25°	5.5	9.8	32.6	-26°
3.7	5.2	8.8	25.9	-33°	5.8	9.4	28.3	-30°	5.2	9.1	28.0	-34°	6.4	11.0	36.6	-28°	5.5	8.8	28.0	-34°	6.4	10.4	34.4	-29°	5.8	9.8	31.4	-31°
4.3	5.2	8.5	24.4	-38°	6.1	9.1	27.1	-34°	5.5	8.5	26.5	-38°	6.7	10.7	35.4	-32°	5.5	8.5	26.5	-39°	6.7	10.4	33.2	-33°	6.1	9.4	30.2	-35°
4.9	5.2	8.2	22.9	-43°	6.1	8.8	25.6	-39°	5.5	8.2	24.4	-44°	7.0	10.7	33.8	-37°	5.5	8.2	24.7	-44°	6.7	10.1	31.7	-37°	6.1	9.4	28.3	-40°
5.5	5.2	7.6	21.0	-48°	5.8	8.8	24.1	-44°	5.2	7.9	22.6	-49°	7.0	10.4	32.3	-41°	5.2	7.6	22.3	-50°	6.7	9.8	29.9	-41°	6.1	8.8	26.8	-44°

Size Mounting Height	7°C Rise																10°C Rise											
	175				200				225				250				300				350				400			
	X	Y	Z	Louver Angle	X	Y	Z	Louver Angle	X	Y	Z	Louver Angle	X	Y	Z	Louver Angle	X	Y	Z	Louver Angle	X	Y	Z	Louver Angle	X	Y	Z	Louver Angle
2.4	6.7	12.5	44.5	-15°	7.0	13.1	47.9	-13°	7.0	13.1	51.2	-16°	7.9	14.6	60.4	-14°	6.4	11.9	44.5	-17°	7.3	13.7	51.5	-14°	7.3	13.4	51.5	-14°
3.0	7.3	13.1	43.9	-19°	7.6	14.0	47.2	-17°	7.9	13.7	50.6	-19°	8.8	15.2	59.7	-17°	7.0	12.5	43.6	-21°	7.9	14.3	50.9	-18°	7.9	14.0	50.9	-17°
3.7	7.9	13.1	43.0	-22°	8.5	14.3	46.3	-20°	8.5	13.7	49.7	-22°	9.4	15.8	59.1	-20°	7.6	12.8	42.7	-25°	8.5	14.6	50.3	-21°	8.5	14.6	50.3	-20°
4.3	8.5	13.4	41.8	-25°	8.8	14.6	45.7	-23°	9.1	14.0	48.8	-25°	9.8	16.5	58.2	-22°	7.9	12.8	41.8	-28°	9.1	14.9	49.4	-24°	9.4	14.6	49.4	-23°
4.9	8.8	13.4	40.8	-28°	9.4	14.6	44.8	-26°	9.4	14.3	47.9	-29°	10.4	16.2	57.6	-25°	8.2	12.8	40.5	-31°	9.8	14.6	48.5	-26°	9.8	14.9	48.5	-26°
5.5	8.8	13.4	39.9	-32°	9.4	14.9	43.9	-29°	9.4	14.3	46.6	-32°	10.4	16.5	56.4	-28°	8.5	12.5	39.3	-34°	10.1	14.9	47.5	-29°	9.8	14.9	47.5	-29°

Throw/Floor Coverage at Various Mounting Heights (cont'd)

Applies to Model F Sizes 125-400

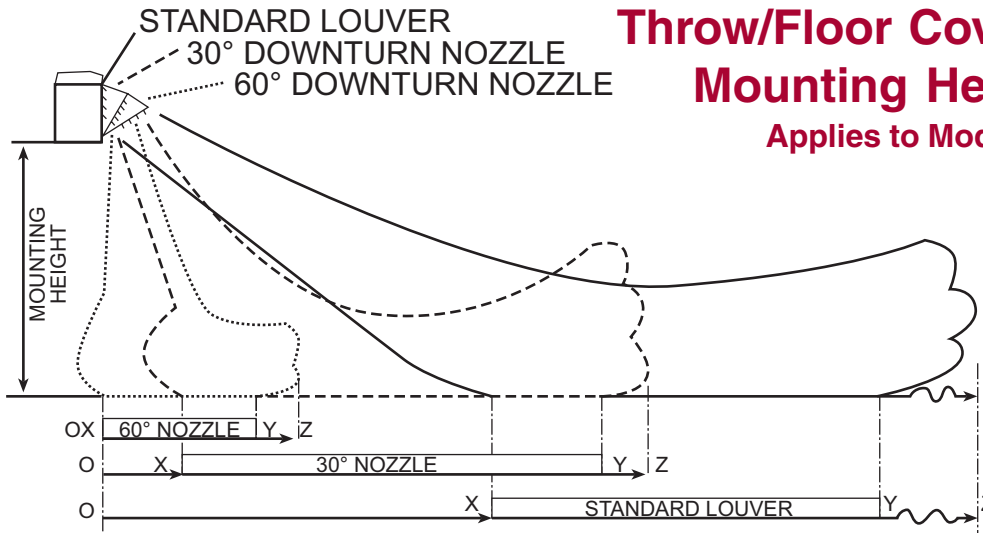

Dimension in feet.

With Standard Horizontal Louvers

Mounting Height	X	Y	Z	X	Y	Z	X	Y	Z	X	Y	Z	X	Y	Z	X	Y	Z
8	14	24	65	14	35	75	13	38	83	12	44	94	12	36	105	12	55	118
10	16	22	58	16	32	72	15	36	78	15	40	88	14	38	96	14	53	112
12	18	20	54	18	30	66	17	34	72	17	38	84	16	35	90	16	49	108
14	--	--	--	--	--	--	20	31	68	19	33	77	18	30	85	18	45	100
16	--	--	--	--	--	--	--	--	--	22	30	72	20	27	80	20	40	92
18	--	--	--	--	--	--	--	--	--	--	--	--	--	--	--	23	35	85

With Downturn Nozzle with 25-65° Range of Air Deflection (30° Nozzle)

Mounting Height	X	Y	Z	X	Y	Z	X	Y	Z	X	Y	Z	X	Y	Z	X	Y	Z
10	10	22	28	10	24	33	10	31	45	8	40	53	8	38	51	--	--	--
12	13	18	26	12	22	30	12	29	43	10	38	50	10	36	48	10	50	70
14	16	16	22	15	20	25	14	26	40	12	36	47	13	34	44	12	47	66
16	--	--	--	--	--	--	16	23	36	14	33	42	15	31	40	14	43	62
18	--	--	--	--	--	--	18	20	30	16	28	36	18	26	34	16	38	58
20	--	--	--	--	--	--	--	--	--	--	--	--	--	--	--	18	34	53
22	--	--	--	--	--	--	--	--	--	--	--	--	--	--	--	21	30	46

With Downturn Nozzle with 50-90° Range of Air Deflection (60° Nozzle)

Mounting Height	X	Y	Z	X	Y	Z	X	Y	Z	X	Y	Z	X	Y	Z	X	Y	Z
12	0	8	20	0	8	22	0	8	25	0	12	30	0	10	28	--	--	--
16	0	10	18	0	10	20	0	10	23	0	14	28	0	12	26	0	12	32
20	0	14	16	0	14	18	0	12	21	0	16	26	0	14	24	0	14	30
24	--	--	--	--	--	--	0	14	18	0	18	24	0	16	20	0	16	28
28	--	--	--	--	--	--	--	--	--	--	--	--	--	--	--	0	18	26
32	--	--	--	--	--	--	--	--	--	--	--	--	--	--	--	0	20	24
36	--	--	--	--	--	--	--	--	--	--	--	--	--	--	0	22	22	--

Dimension in meters.

With Standard Horizontal Louvers

Mounting Height	X	Y	Z	X	Y	Z	X	Y	Z	X	Y	Z	X	Y	Z	X	Y	Z
2.4	4.3	7.3	19.8	4.3	10.7	22.9	4.0	11.6	25.3	3.7	13.4	28.7	3.7	11.0	32.0	3.7	16.8	36.0
3.0	4.9	6.7	17.7	4.9	9.8	21.9	4.6	11.0	23.8	4.6	12.2	26.8	4.3	11.6	29.3	4.3	16.2	34.1
3.7	5.5	6.1	16.5	5.5	9.1	20.1	5.2	10.4	21.9	5.2	11.6	25.6	4.9	10.7	27.4	4.9	14.9	32.9
4.3	--	--	--	--	--	--	6.1	9.4	20.7	5.8	10.1	23.5	5.5	9.1	25.9	5.5	13.7	30.5
4.9	--	--	--	--	--	--	--	--	--	6.7	9.1	21.9	6.1	8.2	24.4	6.1	12.2	28.0
5.5	--	--	--	--	--	--	--	--	--	--	--	--	--	--	7.0	10.7	25.9	--

With Downturn Nozzle with 25-65° Range of Air Deflection (30° Nozzle)

Mounting Height	X	Y	Z	X	Y	Z	X	Y	Z	X	Y	Z	X	Y	Z	X	Y	Z
3.0	3.0	6.7	8.5	3.0	7.3	10.1	3.0	9.4	13.7	2.4	12.2	16.2	2.4	11.6	15.5	--	--	--
3.7	4.0	5.5	7.9	3.7	6.7	9.1	3.7	8.8	13.1	3.0	11.6	15.2	3.0	11.0	14.6	3.0	15.2	21.3
4.3	4.9	4.9	6.7	4.6	6.1	7.6	4.3	7.9	12.2	3.7	11.0	14.3	4.0	10.4	13.4	3.7	14.3	20.1
4.9	--	--	--	--	--	--	4.9	7.0	11.0	4.3	10.1	12.8	4.6	9.4	12.2	4.3	13.1	18.9
5.5	--	--	--	--	--	--	5.5	6.1	9.1	4.9	8.5	11.0	5.5	7.9	10.4	4.9	11.6	17.7
6.1	--	--	--	--	--	--	--	--	--	--	--	--	--	--	--	4.5	10.4	16.2
6.7	--	--	--	--	--	--	--	--	--	--	--	--	--	--	--	6.4	9.1	14.0

With Downturn Nozzle with 50-90° Range of Air Deflection (60° Nozzle)

Mounting Height	X	Y	Z	X	Y	Z	X	Y	Z	X	Y	Z	X	Y	Z	X	Y	Z
3.7	0.0	2.4	6.1	0.0	2.4	6.7	0.0	2.4	7.6	0.0	3.7	9.1	0.0	3.0	8.5	--	--	--
4.9	0.0	3.0	5.5	0.0	3.0	6.1	0.0	3.0	7.0	0.0	4.3	8.5	0.0	3.7	7.9	0.0	3.7	9.8
6.1	0.0	4.3	4.9	0.0	4.3	5.5	0.0	3.7	6.4	0.0	4.9	7.9	0.0	4.3	7.3	0.0	4.3	9.1
7.3	--	--	--	--	--	--	0.0	4.3	5.5	0.0	5.5	7.3	0.0	4.9	6.1	0.0	4.9	8.5
8.5	--	--	--	--	--	--	--	--	--	--	--	--	--	--	--	0.0	5.5	7.9
9.8	--	--	--	--	--	--	--	--	--	--	--	--	--	--	--	0.0	6.1	7.3
11.0	--	--	--	--	--	--	--	--	--	--	--	--	--	--	--	0.0	6.7	6.7

KEY:

O-X = Feet from heater to start of floor coverage

O-Y = Feet to end of floor coverage

O-Z = Feet to end of throw (50 ft per minute velocity)

NOTES: Data based on 80°F entering air and 60°F rise through the unit. Standard louvers set at maximum deflection are effective as indicated when ceiling height above heater is not over 4 ft. For higher mounting height or where spot heating is required, choose outlet and mounting height giving coverage to floor. Mounting close to the ceiling provides maximum heat utilization.

Throw/Floor Coverage at Various Mounting Heights (cont'd)

Applies to Model B Sizes 125-400
 Floor Coverage with 50-90 degree
 Variable Air Deflection Downturn Nozzle

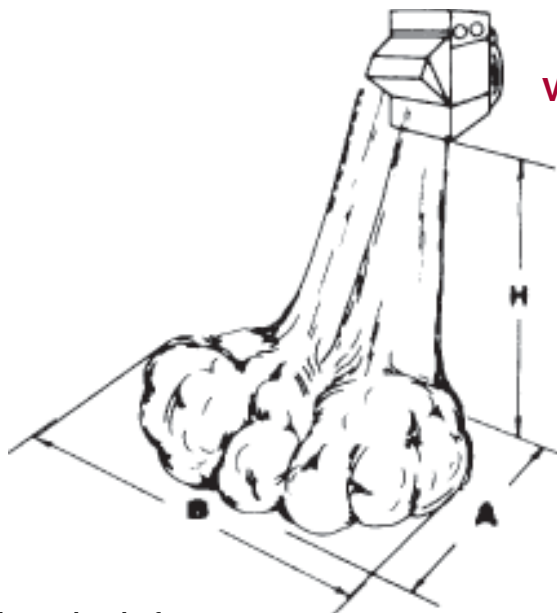

Dimension in feet.

Blower Model	CFM	Mounting Height - H															
		12 ft		16 ft		20 ft		24 ft		28 ft		32 ft		36 ft		40 ft	
		A	B	A	B	A	B	A	B	A	B	A	B	A	B	A	B
125	1545	20	22	18	20	16	18	--	--	--	--	--	--	--	--	--	--
165	2090	24	26	22	24	20	22	--	--	--	--	--	--	--	--	--	--
200	2470	--	--	26	28	24	26	20	22	--	--	--	--	--	--	--	--
250	3090	--	--	30	32	28	30	24	26	--	--	--	--	--	--	--	--
300	3710	--	--	--	--	32	34	30	32	28	30	26	28	24	26	--	--
400	4950	--	--	--	--	36	38	34	36	32	34	30	32	28	30	24	26

Dimension in meters.

Blower Model	M ³ /hr	Mounting Height - H															
		3.7M		4.9M		6.1M		7.3M		8.5M		9.8M		11.0M		12.2M	
		A	B	A	B	A	B	A	B	A	B	A	B	A	B	A	B
125	2625	6.1	6.7	5.5	6.1	4.9	5.5	--	--	--	--	--	--	--	--	--	--
165	3551	7.3	7.9	6.7	7.3	6.1	6.7	--	--	--	--	--	--	--	--	--	--
200	4196	--	--	7.9	8.5	7.3	7.9	6.1	6.7	--	--	--	--	--	--	--	--
250	5250	--	--	9.1	9.8	8.5	9.1	7.3	7.9	--	--	--	--	--	--	--	--
300	6303	--	--	--	--	9.8	10.4	9.1	9.8	8.5	9.1	7.9	8.5	7.3	7.9	--	--
400	8410	--	--	--	--	11.0	11.6	10.4	11.0	9.8	10.4	9.1	9.8	8.5	9.1	7.3	7.9

KEY:

A = Throw

B = Spread (Side to side coverage with standard louvers)

H = Mounting Height

NOTES: Data based on 80°F entering air temperature and 60°F rise through the unit. Standard horizontal louver set for maximum down deflection. Table and drawing show approximate floor coverage at various mounting heights. NOTE that throw "A" and sideward spread "B" are increased as mounting height is reduced, due to floor bounce effect. Conversely the floor coverage reduces as mounting height increases. Horizontal louvers can be used to spread throw area "A" forward from the heater, and vertical louvers can be used to increase sideward spread "B". Vertical louvers set at maximum deflection will increase spread "B" approximately 10 feet, but will reduce maximum mounting height 4 feet. EXAMPLE: B200 at 20 ft. mounting height with standard louver setting gives a floor coverage of "A" = 24' x "B" = 26'. Using vertical louvers set at maximum sideward spread, the maximum mounting height would be 16 feet, and the floor coverage would be "A" = 26' and "B" = 28' plus 10' or 38'.

Sound (in dBA) from Models UDAP and UDAS at various distances.

Size	5 Feet	10 Feet	15 Feet
	1.5 meters	3.0 meters	4.6 meters
30	59	47	40
45	59	47	40
60	59	47	40
75	69	55	49
100	N/A	58	54
125	N/A	59	55
150	N/A	55	51
175	N/A	55	52
200	N/A	56	53
225	N/A	59	56
250	N/A	59	56
300	N/A	62	59
350	N/A	64	61
400	N/A	65	62

Sound (in dBA) from Models UDBP and UDBS at a distance of 15 feet (4.6 meters).

Blower Speed	Size					
	30	45	60	75	100	125
Low	57	50	59	60	59	59
Medium	58	53	62	63	63	63
High	60	57	64	64	66	66

Temperature Rise	Size							
	150	175	200	225	250	300	350	400 *
75°F (24°C)	51	56	58	61	63	64	65	67
60°F (16°C)	56	59	62	63	66	70	72	71
45°F (7°C)	62	69	71	71	75	76	78	79

* Note: The temperature rises of the Model 400 are 80°F (27°C), 70°F (21°C), and 50°F (10°C).

Blower Curves for Sizes 30 - 45 (Direct Drive Blower Motors)

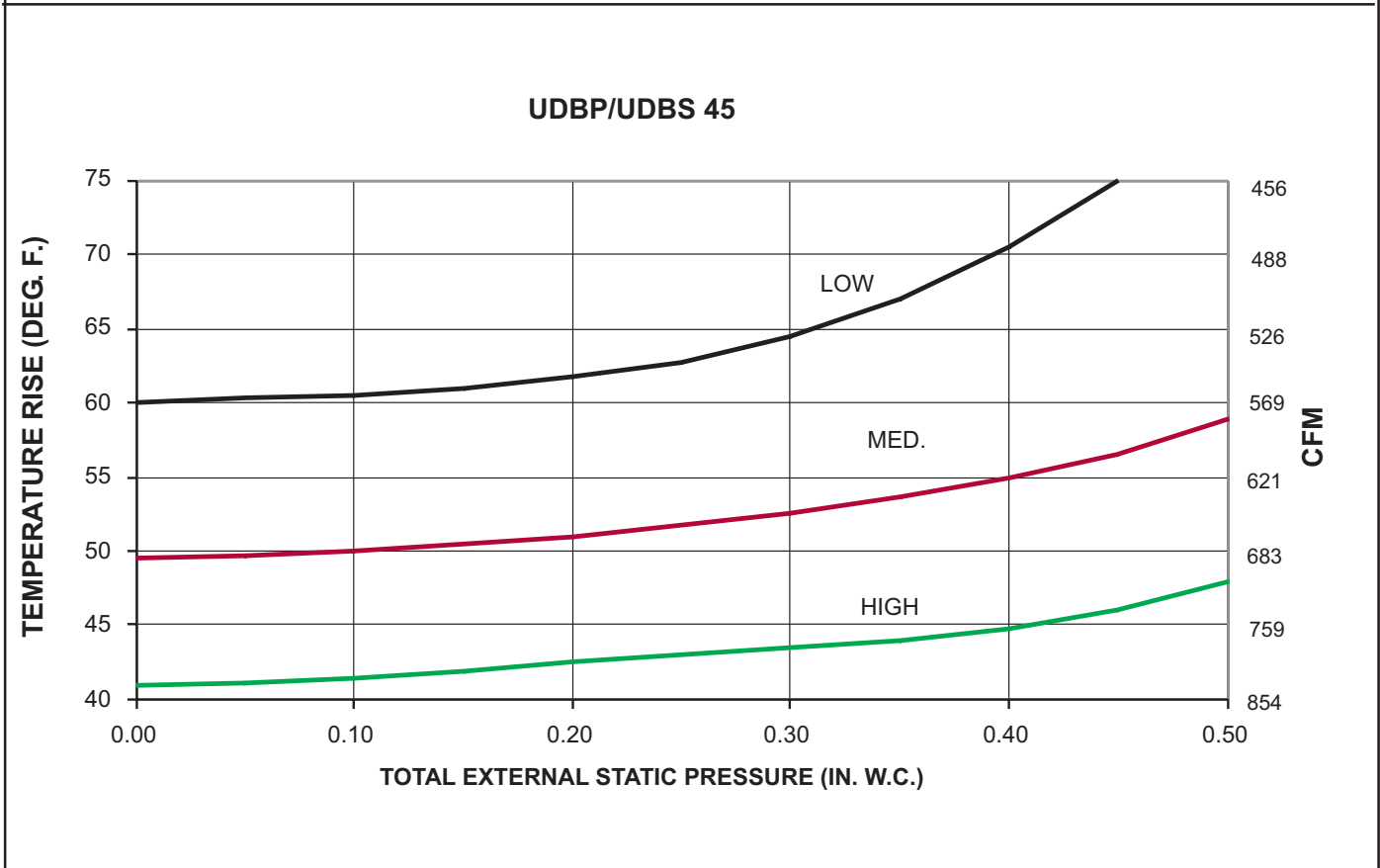
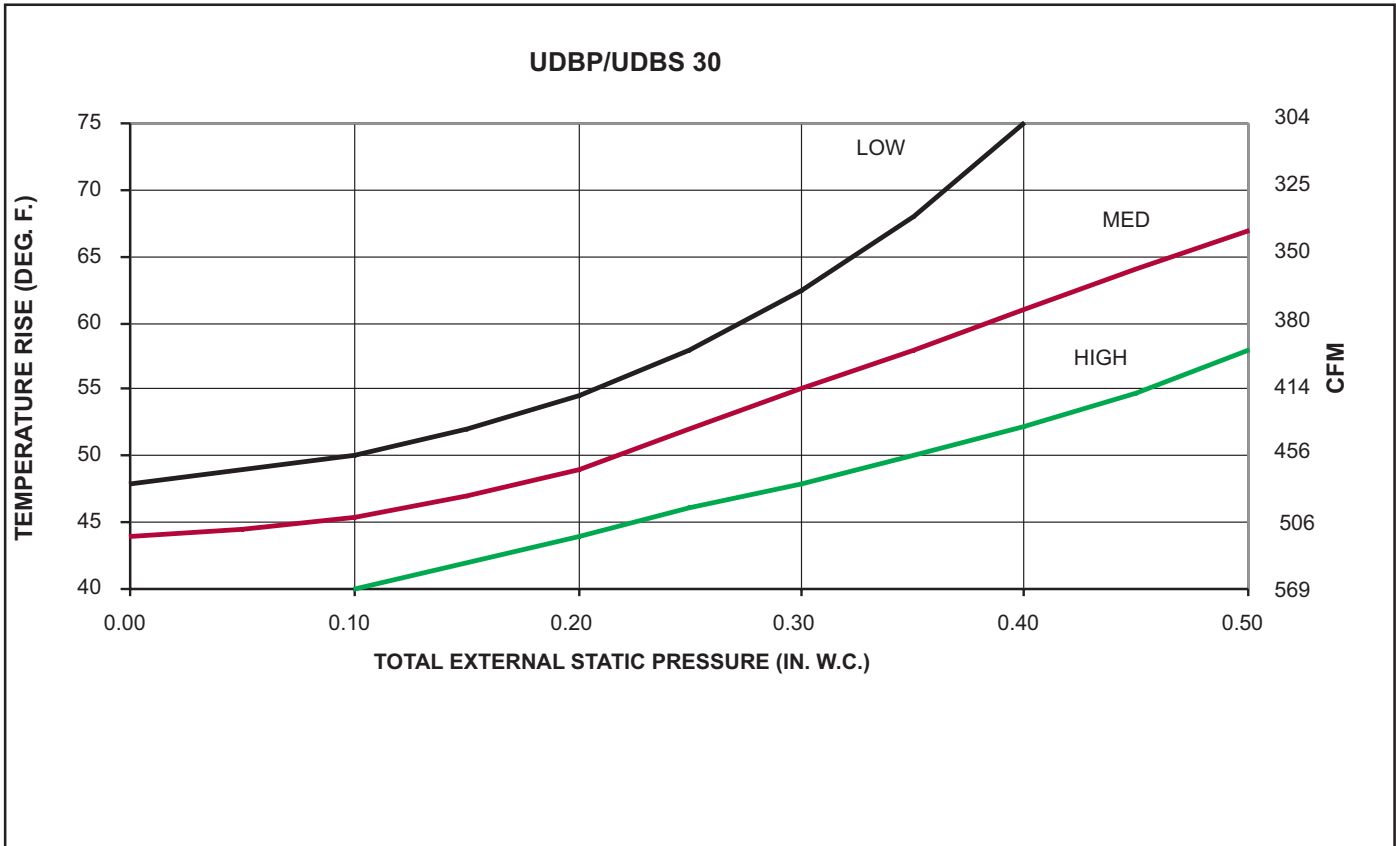

Blower Curves for Sizes 60 - 75 (Direct Drive Blower Motors)

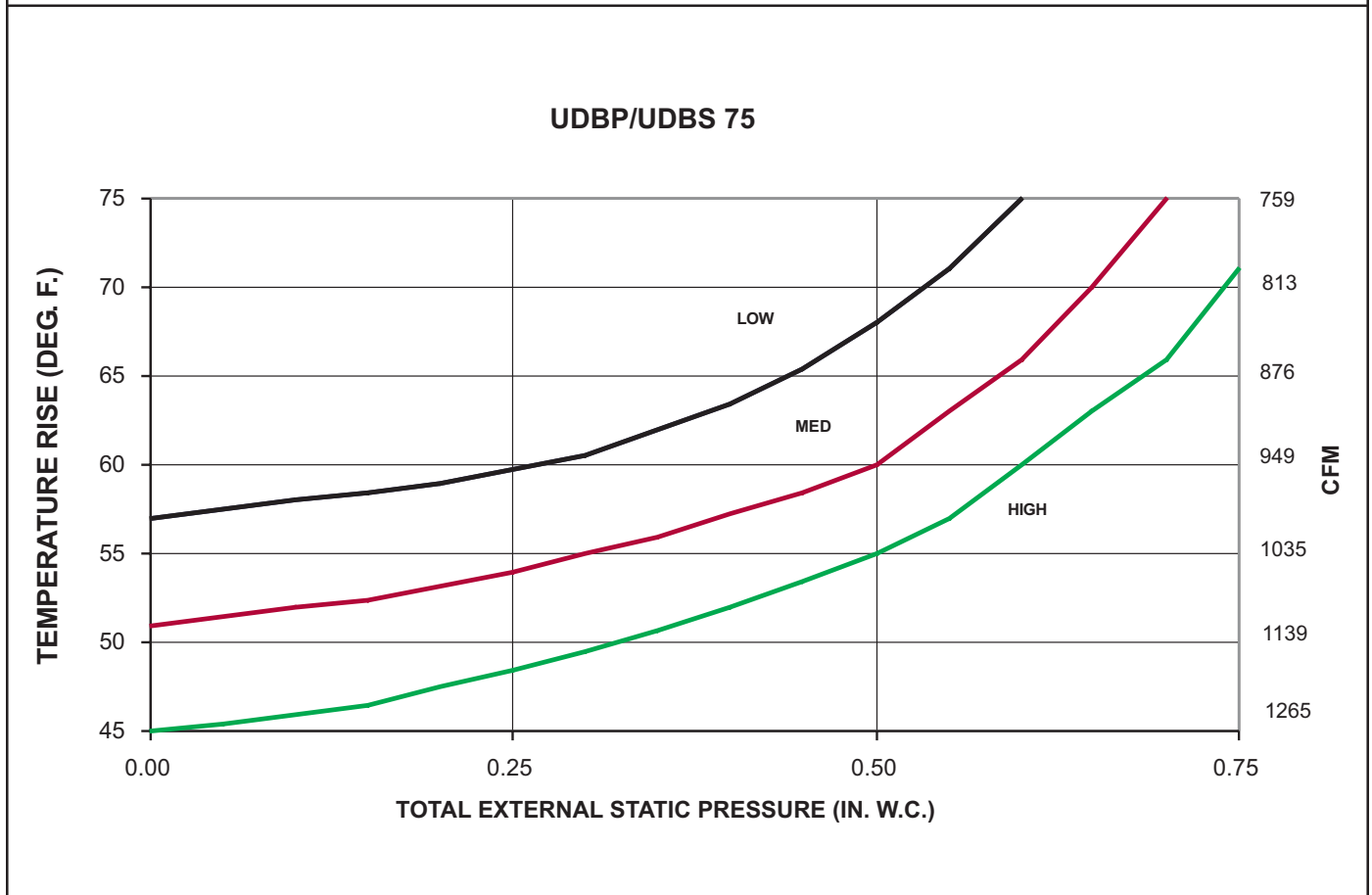
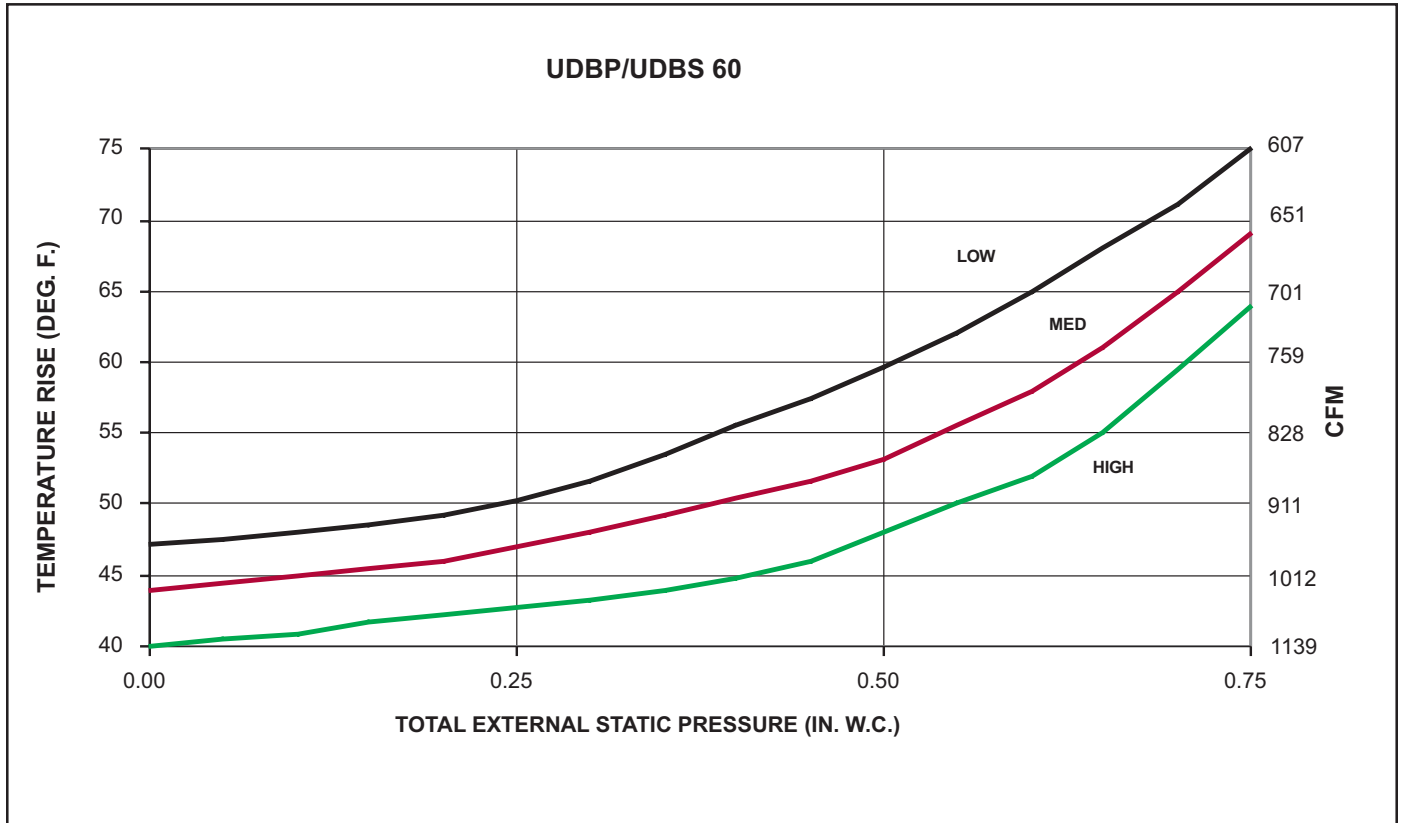



BLOWER CHARTS - Models UDBP and UDBS (cont'd)

Blower Curves for Sizes 100 - 125 (Direct Drive Blower Motors)

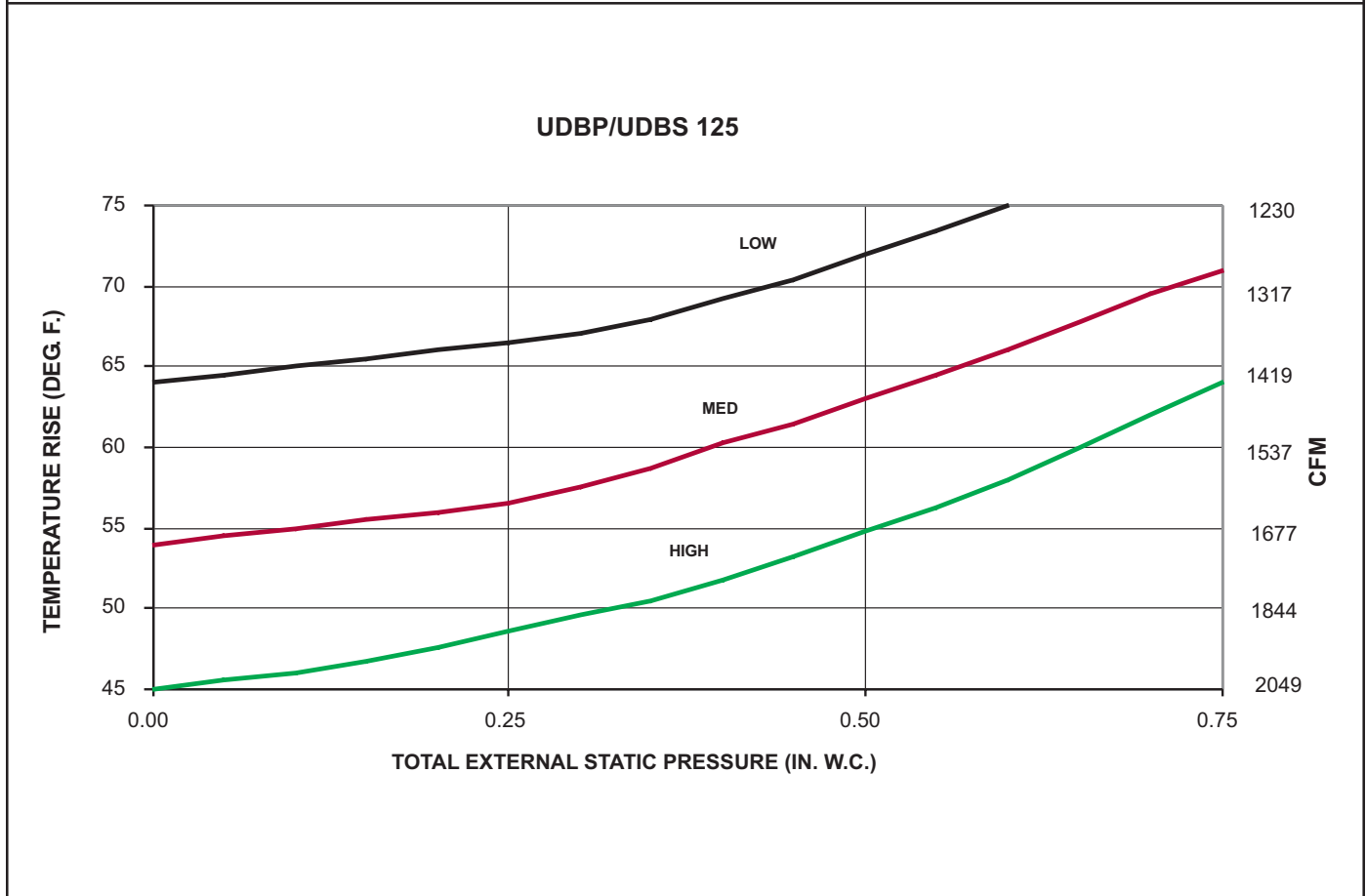
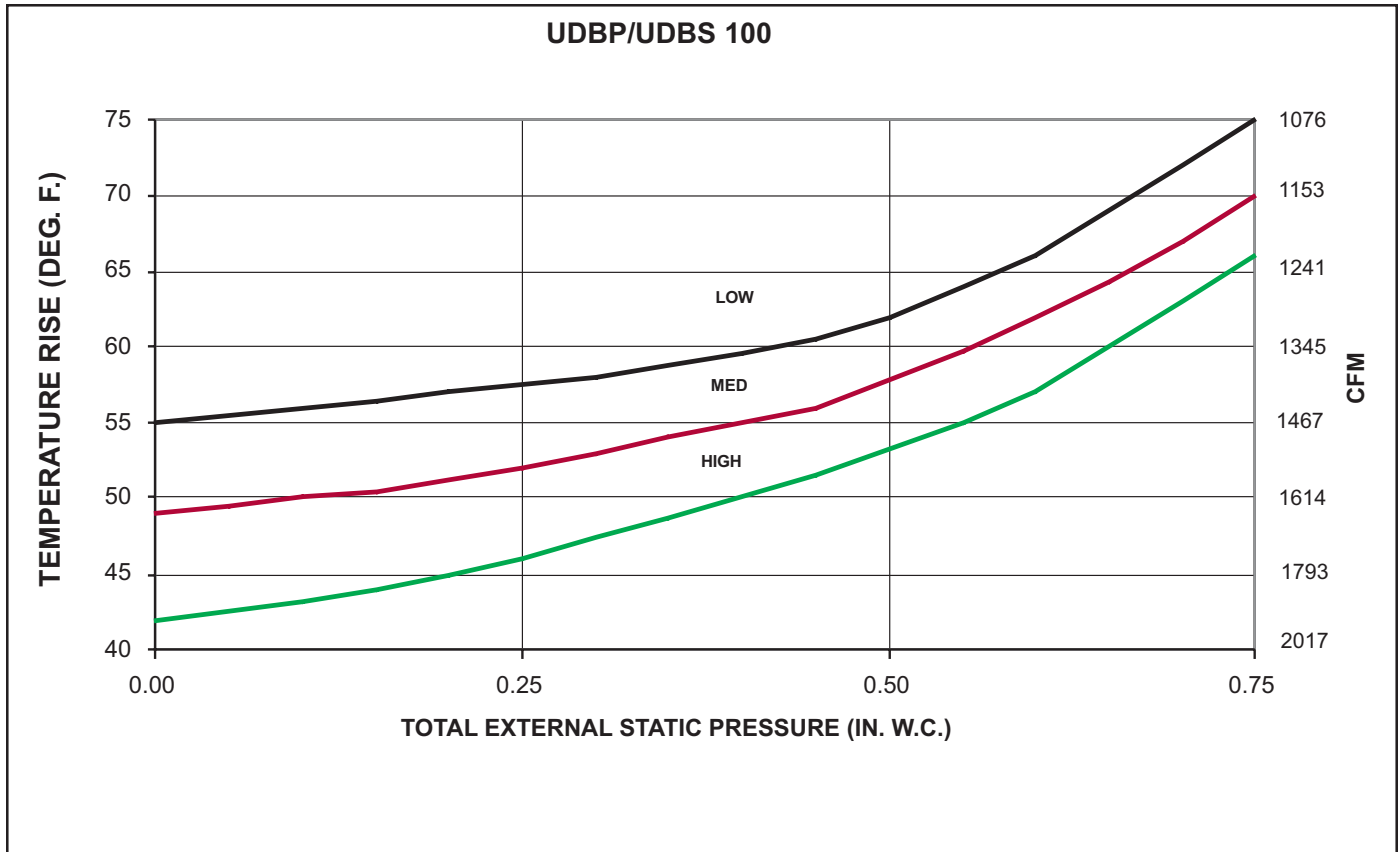

Blower Chart for Sizes 150 - 400
 Standard motor and drive shown shaded.

UDBP and UDBS	TEMP RISE °F	CFM	Nozzle Option with Louvers				EXTERNAL Static Pressure					
			30°		60°		0"		.25"		.50"	
			RPM	BHP	RPM	BHP	RPM	BHP	RPM	BHP	RPM	BHP
150	45°	2562	730	0.43	730	0.43	730	0.43	840	0.55	930	0.68
	60°	1921	520	0.25	520	0.25	520	0.25	655	0.35	780	0.43
	75°	1537	405	0.17	405	0.17	405	0.17				
175	45°	2989	910	0.68	910	0.68	910	0.68	960	0.83	1055	0.98
	60°	2242	660	0.44	660	0.44	660	0.44	775	0.51	865	0.63
	75°	1793	545	0.28	545	0.28	545	0.28	665	0.38		
200	45°	3416	1020	0.91	1020	0.91	1020	0.91	1090	1.07	1160	1.24
	60°	2562	730	0.49	730	0.49	730	0.49	885	0.63	935	0.76
	75°	2049	600	0.34	600	0.34	600	0.34	720	0.45	830	0.51
225	45°	3843	740	1.05	740	1.05	740	1.05	845	1.22	885	1.40
	60°	2882	530	0.60	530	0.60	530	0.60	670	0.74	730	0.89
	75°	2306	430	0.42	430	0.42	430	0.42	565	0.54	640	0.66
250	45°	4270	900	1.30	900	1.30	900	1.30	935	1.49	980	1.69
	60°	3202	660	0.73	660	0.73	660	0.73	730	0.88	790	1.04
	75°	2562	570	0.56	570	0.56	570	0.56	610	0.69	685	0.83
300	45°	5123	990	2.04	990	2.04	990	2.04	1020	2.29	1070	2.55
	60°	3843	735	1.29	735	1.29	735	1.29	795	1.49	865	1.71
	75°	3074	600	0.95	600	0.95	600	0.95				
350	45°	5977	1040	2.95	1040	2.95	1040	2.95	1075	3.24	1130	3.54
	60°	4483	800	1.80	800	1.80	800	1.80	850	2.04	930	2.28
	75°	3586	630	1.33	630	1.33	630	1.33	720	1.45		
400	50°	6185	1055	3.56	1055	3.56	1055	3.56	1090	3.86	1170	4.17
	70°	4392	790	1.98	790	1.98	790	1.98	875	2.17	1020	2.42
	80°	4100	675	1.76	675	1.76	675	1.76	750	1.99		

Blower Chart Model B with Belt Drive Motor

Model B and BE unit heaters are designed to handle up to .5" w.c. of static pressure with temperature rises as shown from 45°F to 75°F. The following chart indicates the CFM, the motor HP, and the optional drive required to achieve the desired temperature rise with external pressures from 0 to .5" w.c.

Drive Option Key (see chart on next page):

AM —	The "AM" drive will provide the selected CFM and temperature rise when installed with the total external static pressure listed but MAY require field-adjustment of the blower speed (CFM). Check the temperature rise and the motor amps. If adjustment is needed, follow "Blower Speed Adjustment" instructions in the heater installation manual.	STD	The standard drive as set at the factory provides the selected CFM and temperature rise when installed with the external static pressure listed.
		STD	The standard drive will provide the selected CFM and temperature rise when installed with the total external static pressure listed but REQUIRES field-adjustment of the blower speed (CFM). Follow the "Blower Speed Adjustment" instructions in the heater installation manual.
N.R.	The temperature rise and static pressure combination is not recommended for the heater size.		

NOTES: (1) Sizes 50-100 do not show a standard drive because they have a standard direct drive blower motor. For a Size 50-100 with an optional belt-driven motor and blower, an "AM" option must be selected.
 (2) If the unit includes an optional blower cabinet, see the chart below for pressure drop information.

Temp. Rise	Heater Size																			
	25		50		75		100		125		165		200		250		300		400	
	Filter Thickness																			
	1"	2"	1"	2"	1"	2"	1"	2"	1"	2"	1"	2"	1"	2"	1"	2"	1"	2"	1"	2"
75°F	0.004	0.007	0.01	0.015	0.018	0.032	0.032	0.055	0.05	0.075	0.018	0.03	0.026	0.045	0.017	0.028	0.024	0.038	0.026	0.045
70°F	0.004	0.008	0.01	0.018	0.023	0.034	0.036	0.058	0.055	0.1	0.021	0.035	0.03	0.052	0.019	0.031	0.027	0.045	0.03	0.052
65°F	0.005	0.009	0.011	0.019	0.024	0.04	0.041	0.069	0.065	0.12	0.024	0.04	0.035	0.06	0.023	0.036	0.03	0.053	0.035	0.06
60°F	0.005	0.009	0.014	0.023	0.028	0.047	0.052	0.087	0.085	0.14	0.028	0.047	0.041	0.07	0.025	0.042	0.035	0.061	0.041	0.07
55°F	0.006	0.01	0.016	0.027	0.034	0.057	0.065	0.105	0.1	0.16	0.033	0.057	0.047	0.08	0.03	0.051	0.041	0.072	0.047	0.08
50°F	0.006	0.01	0.018	0.029	0.041	0.069	0.07	0.12	0.13	N.R.	0.04	0.068	0.057	0.095	0.035	0.062	0.04	0.085	0.057	0.095
45°F	0.007	0.011	0.024	0.04	0.05	0.086	0.092	0.16	0.18	N.R.	0.049	0.082	0.07	0.14	0.043	0.074	0.065	0.12	0.07	0.14



Optional Blower/Filter Cabinet for Models B

- Shipped separately for field assembly and installation
- Filter Rack (less filters)
- Filter Rack with 1" or 2" Permanent Filters

(3) Key to Drive Options

AM1 401-450 RPM	AM6 651-700 RPM	AM10 851-900 RPM	AM14 1051-1100 RPM
AM2 451-500 RPM	AM7 701-750 RPM	AM11 901-950 RPM	AM15 1101-1150 RPM
AM3 501-550 RPM	AM8 751-800 RPM	AM12 951-1000 RPM	AM16 1151-1200 RPM
AM4 551-600 RPM	AM9 801-850 RPM	AM13 1001-1050 RPM	AM17 1201-1250 RPM
AM5 601-650 RPM			

Blower Chart - Models B with Belt Drive Motor

Model B & BE	Temp Rise °F	CFM	Total External Static Pressure ("w.c.)											
			0		0.1		0.2		0.3		0.4		0.5	
			Drive	HP	Drive	HP	Drive	HP	Drive	HP	Drive	HP	Drive	HP
Size 125	75	1235	AM4	1/3	AM4	1/3	STD	1/3	STD	1/3	AM7	1/3	AM8	1/3
	70	1320	STD	1/3	STD	1/3	STD	1/3	AM7	1/3	AM8	1/3	AM9	1/2
	60	1540	STD	1/3	STD	1/3	AM7	1/3	AM8	1/2	AM9	1/2	AM10	1/2
	50	1850	AM7	1/2	AM8	1/2	AM9	1/2	AM9	1/2	AM10	1/2	AM11	3/4
	45	2055	AM8	1/2	AM9	3/4	AM10	3/4	AM11	3/4	AM11	3/4	AM13	3/4
Size 165	75	1630	AM3	1/2	STD	1/2	STD	1/2	STD	1/2	AM7	1/2	AM8	1/2
	70	1750	AM3	1/2	STD	1/2	STD	1/2	AM6	1/2	AM7	1/2	AM8	1/2
	60	2040	STD	1/2	STD	1/2	AM7	1/2	AM7	3/4	AM8	3/4	AM8	3/4
	50	2440	AM7	3/4	AM7	3/4	AM8	3/4	AM9	3/4	AM10	1	AM11	1
	45	2715	AM9	1	AM9	1	AM10	1	AM11	1	AM11	1	AM12	1
Size 200	75	1975	STD	1/2	STD	1/2	STD	1/2	STD	1/2	AM4	1/2	AM5	3/4
	70	2115	STD	1/2	STD	1/2	STD	1/2	STD	1/2	AM4	1/2	AM5	3/4
	60	2470	STD	1/2	STD	1/2	AM3	1/2	AM4	3/4	AM5	3/4	AM6	3/4
	50	2960	AM3	3/4	AM4	3/4	AM4	3/4	AM5	1	AM6	1	AM6	1
	45	3290	AM4	1	AM4	1	AM5	1	AM6	1	AM6	1	AM7	1 1/2
Size 250	75	2470	AM2	1/2	AM2	1/2	STD	3/4	STD	3/4	AM5	3/4	AM5	3/4
	70	2645	AM2	1/2	STD	3/4	STD	3/4	STD	3/4	AM5	3/4	AM6	3/4
	60	3085	STD	3/4	STD	3/4	AM5	3/4	AM5	1	AM6	1	AM7	1
	50	3700	AM5	1	AM5	1 1/2	AM6	1 1/2	AM7	1 1/2	AM7	1 1/2	AM8	1 1/2
	45	4115	AM6	1 1/2	AM7	1 1/2	AM7	2	AM8	2	AM8	2	AM8	2
Size 300	75	2960	STD	1	STD	1	STD	1	STD	1	AM6	1	AM6	1
	70	3170	STD	1	STD	1	STD	1	STD	1	AM6	1	AM7	1 1/2
	60	3700	STD	1	STD	1	AM6	1 1/2	AM7	1 1/2	AM7	1 1/2	AM8	1 1/2
	50	4440	AM7	2	AM8	2	AM8	2	AM9	2	AM9	3	AM10	3
	45	4935	AM9	3	AM9	3	AM9	3	AM10	3	AM11	3	AM11	3
Size 400	75	3950	AM2	1 1/2	STD	1 1/2	STD	1 1/2	STD	1 1/2	STD	1 1/2	AM6	1 1/2
	70	4230	STD	1 1/2	STD	1 1/2	STD	1 1/2	STD	1 1/2	AM6	1 1/2	AM6	1 1/2
	60	4935	STD	1 1/2	STD	1 1/2	STD	1 1/2	AM6	2	AM7	2	AM7	2
	50	5925	AM7	3	AM8	3	AM8	3	AM9	3	AM9	3	AM9	3
	45	6580	AM9	5	AM9	5	AM10	5	AM11	5	AM11	5	AM12	5
B & BE Model	Rise °F Temp	CFM	Drive	HP	Drive	HP	Drive	HP	Drive	HP	Drive	HP	Drive	HP
			0		0.1		0.2		0.3		0.4		0.5	
			Total External Static Pressure ("w.c.)											



Blower Curves Model B with Direct Drive Motor

The blower curves for Models B (Sizes 25, 50, 75 and 100) with direct drive motors indicate the temperature rise available for each size of heater at a given total external static pressure. These units are designed and certified for total external static pressures up to .5" w.c. and temperature rises from 45°-75°F.

The direct drive motors are equipped with multispeed taps for speed adjustment as indicated on the curve charts. Models 25 and 75 are factory-wired to the medium speed tap; Models 50 and 100 are factory-wired to the high-speed tap.

NOTE: If the heater includes a blower cabinet, refer to appropriate pressure drop chart.

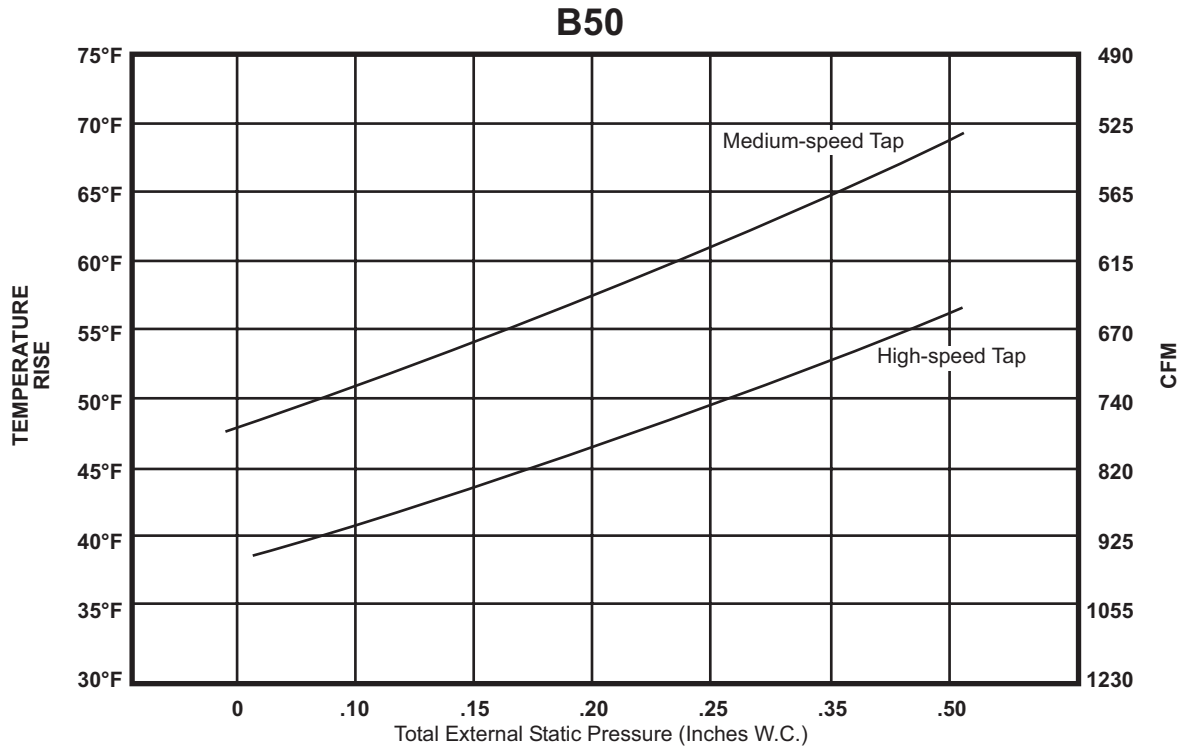
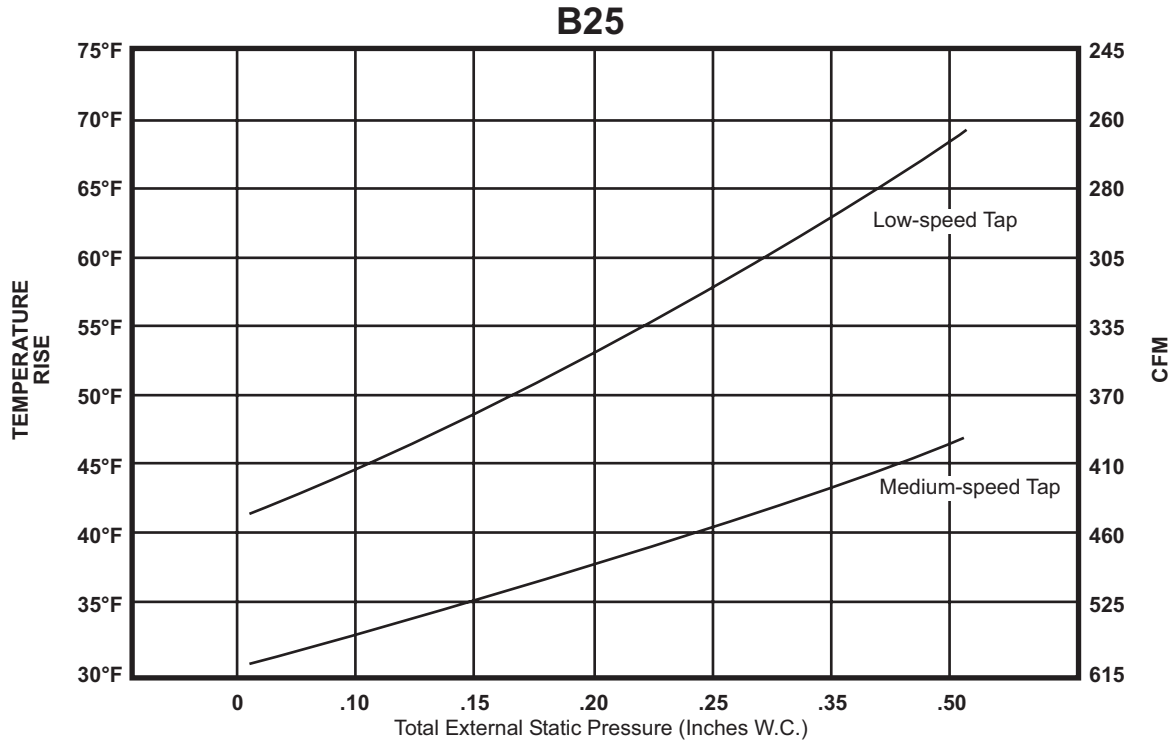

Blower Curves (cont'd)

Apply to Models B with Direct-Drive Motor

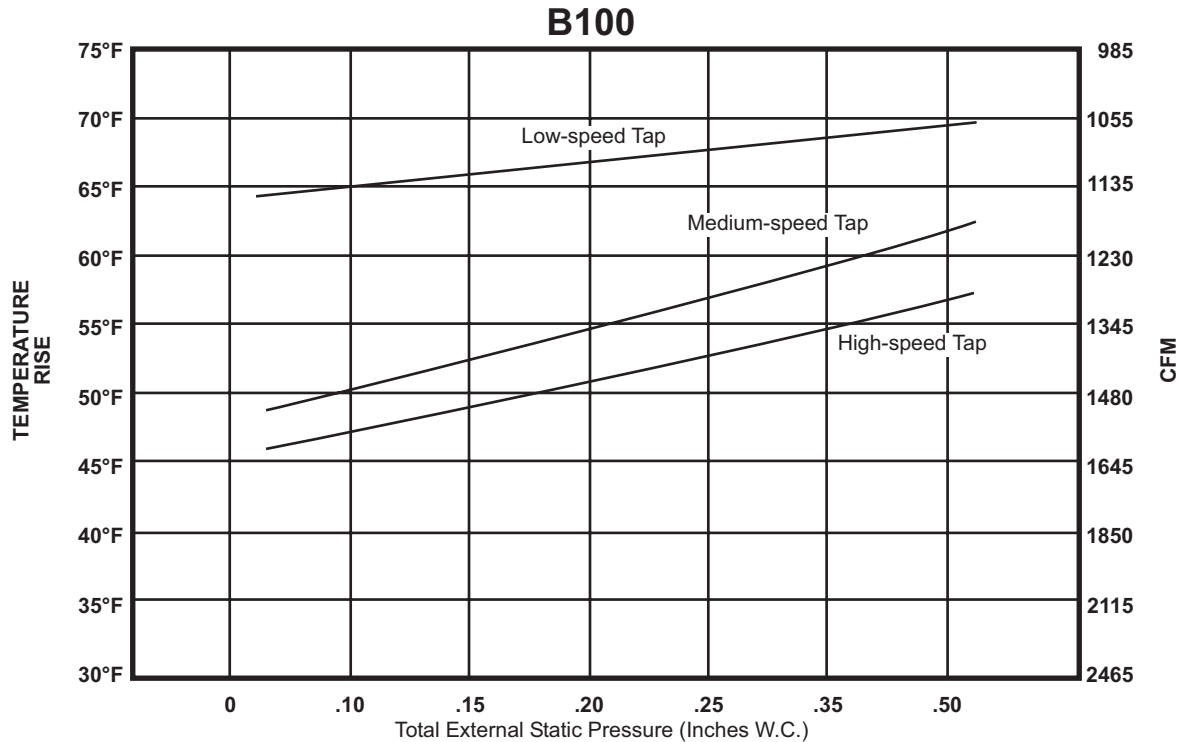
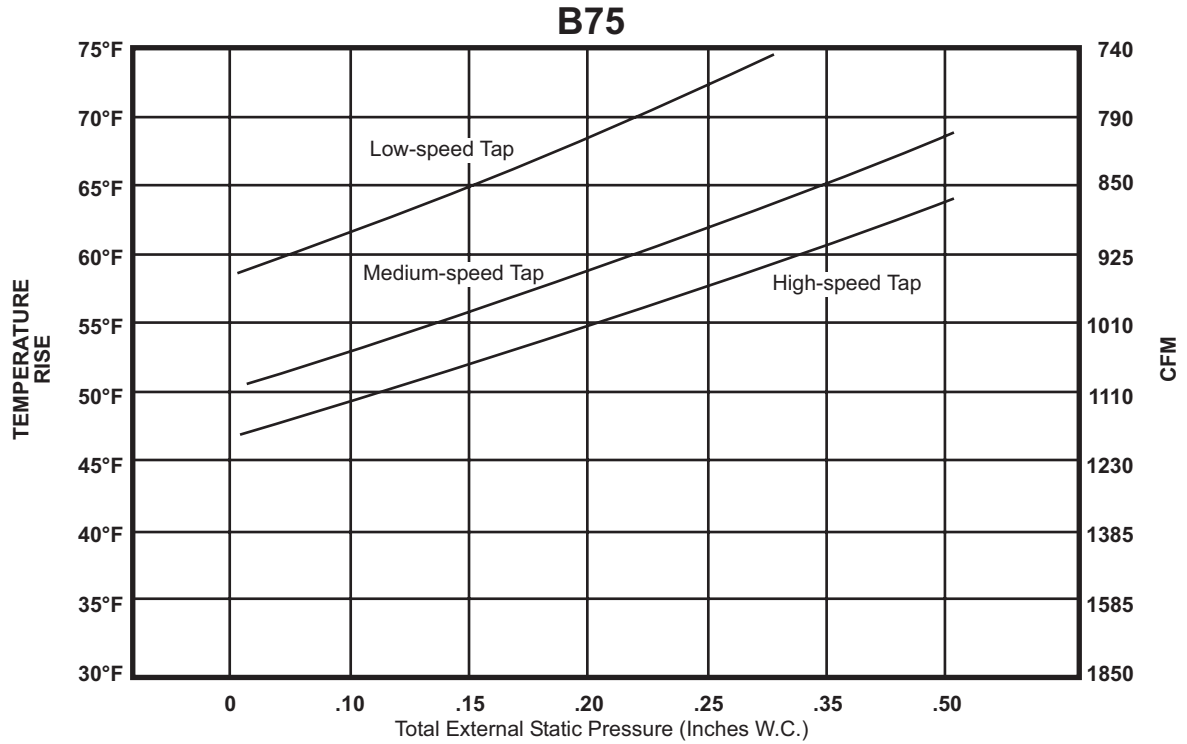

REZNOR[®] MOTOR FULL LOAD AMP TABLE

HP	Type	FLA	RPM	V	PH	HP	Type	FLA	RPM	V	PH	HP	Type	FLA	RPM	V	PH	
0.25	Open	5.1	1750	120	1	0.75	Open	1.0	1750	460	3	1.5	TEFC	2.7	1750	460	3	
		2.1	1750	208	1			0.7	1750	575	3			1.6	1750	575	3	
		2.3	1750	230	1			11.0	1750	120	1			16.4	1750	120	1	
		1.1	1750	208	3			6.3	1750	208	1			9.5	1750	208	1	
		1.4	1750	230	3			5.5	1750	240	1			8.2	1750	230	1	
		.75	1750	460	3			2.9	1750	208	3			4.3	1750	208	3	
0.25	TEFC	3.6	1750	120	1	0.75	TEFC	2.6	1750	240	3	2.0	Open	20.4	1750	120	1	
		2.2	1750	208	1			1.3	1750	460	3			10.0	1750	208	1	
		1.9	1750	230	1			11.0	1750	120	1			10.2	1750	230	1	
		1.6	1750	208	3			5.4	1750	208	1			7.0	1750	208	3	
		1.4	1750	230	3			5.5	1750	230	1			6.6	1750	230	3	
		0.7	1750	460	3			2.0	1750	208	3			3.5	1750	460	3	
0.33	Open	5.5	1750	120	1	1.0	Open	13.0	1750	120	1	2.0	TEFC	24.0	1750	120	1	
		3.2	1750	208	1			7.5	1750	208	1			12.0	1750	230	1	
		2.8	1750	230	1			6.5	1750	240	1			6.5	1750	208	3	
		1.4	1750	208	3			3.7	1750	208	3			5.8	1750	230	3	
		1.6	1750	230	3			3.2	1750	240	3			2.9	1750	460	3	
		0.8	1750	460	3			1.6	1750	460	3			2.3	1750	575	3	
0.33	TEFC	4.6	1750	120	1	1.0	TEFC	13.0	1750	120	1	3.0	Open	14.0	3600	208	1	
		2.3	1750	208	1			6.5	1750	230	1			12.4	3600	230	1	
		2.4	1750	230	1			3.3	1750	208	3			9.0	3600	208	3	
		1.2	1750	208	3			3.4	1750	230	3			8.6	3600	230	3	
		1.2	1750	230	3			1.7	1750	460	3			4.3	3600	460	3	
		0.6	1750	460	3			1.4	1750	575	3			3.6	3600	575	3	
0.50	Open	8.8	1750	120	1	1.5	Open	15.0	1750	120	1	3.0	TEFC	30.0	3600	120	1	
		5.1	1750	208	1			8.3	1750	208	1			15.0	3600	230	1	
		4.4	1750	230	1			7.5	1750	230	1			8.5	3600	208	3	
		3.0	1750	208	3			5.6	1750	208	3			8.2	3600	230	3	
		2.5	1750	230	3			5.0	1750	230	3			4.1	3600	460	3	
		1.0	1750	460	3									3.0	3600	575	3	
0.50	TEFC	7.0	1750	120	1													
		3.4	1750	208	1													
		3.5	1750	230	1													
		2.3	1750	208	3													
		2.3	1750	208	3													
		2.0	1750	230	3													

REZNOR®

Installation Procedures

WARNING: Gas-fired appliances are not designed for use in hazardous atmospheres containing flammable vapors or combustible dust, or atmospheres containing chlorinated or halogenated hydrocarbons.

Installations in public garages or airplane hangars are permitted when in accordance with ANSI Z223.1 and NFPA 54 codes or CAN1-B149 and enforcing authorities.

FOR YOUR SAFETY

What to do if you smell gas:

- **Do not try to light any appliance.**
- **Do not touch any electrical switch; do not use any phone in your building.**
- **Immediately call your gas supplier from a neighbor's phone. Follow the gas supplier's instructions.**
- **If you cannot reach your gas supplier, immediately call your fire department.**

FOR YOUR SAFETY

Do not store or use gasoline or other flammable vapors and liquids in the vicinity of this or any other appliance.

WARNING: Improper installation, adjustment, alteration, service, or maintenance can cause property damage, injury, or death. Read the installation, operation, and maintenance instructions thoroughly before installing or servicing this equipment.

Requirements for installation vary depending on the model of heater and the type of installation. Follow the manufacturer's instructions and comply with all applicable codes.

Some venting requirements that apply to specific gas-fired models are shown on the following pages.

OPTIONAL POWER VENTING OF GRAVITY VENTED UNITS - Models F and B

Use only the Reznor® power venter designed for the particular model and size of heater.

Understand the operation before installing. When a venter is used with a heater, the room thermostat turns the venter on and off, and the venter turns the gas controls on and off. When the space calls for heat, the room thermostat contacts close the circuit which starts the venter. When the venter starts, air from the venter blower closes an air switch that is built into the venter.

Closing of the air flow switch sends an electric current to the burner controls, opening the gas valve and sending gas to the burners. When the thermostat is satisfied, the thermostat turns off the venter and the gas controls. As the venter blower stops, the airflow switch resets to the open position.

REZNOR®

Venting/Inlet Air for Separated Combustion Models - Applies to Models UDAS, UDBS and SHE

Separated-combustion principles used in these Reznor® products.

- Air for combustion is mechanically induced from outside the building, preventing dirt, lint, dust or other contaminants in the indoor atmosphere from entering the burner or combustion zone of the furnace.
- The airflow is metered to provide optimum and efficient combustion that is unaffected by negative building pressure or wind.
- After combustion, the air is exhausted back to the outdoor atmosphere.

Reznor® separated combustion products provide all of these benefits while requiring only one building penetration. See the venting illustrations.

IMPORTANT NOTE: The following illustrations do not accurately picture all models, but the fundamental principle is the same. Refer to the heater installation manual for specific vent/inlet air requirements.

Typical installation of a horizontal vent/inlet air terminal and concentric adapter

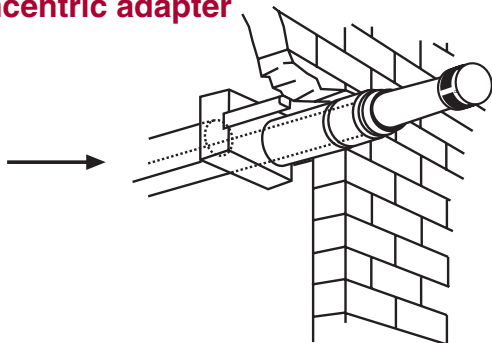

Model UDAS - VENT/COMBUSTION AIR INLET ARRANGEMENTS FOR A REZNOR® SEPARATED COMBUSTION HEATER

A Model UDAS heater **requires** installation of either the horizontal or vertical vent/combustion air arrangement illustrated below. A horizontal or vertical kit must be selected. The installer must comply with all instructions provided with the heater.

Model UDBS - VENT/COMBUSTION AIR INLET ARRANGEMENTS FOR A REZNOR® SEPARATED COMBUSTION HEATER

A Model UDBS heater **requires** installation of either the horizontal or vertical vent/combustion air arrangement illustrated below. A horizontal or vertical kit must be selected. The installer must comply with all instructions provided with the heater.

Typical installation of a vertical vent terminal and concentric adapter

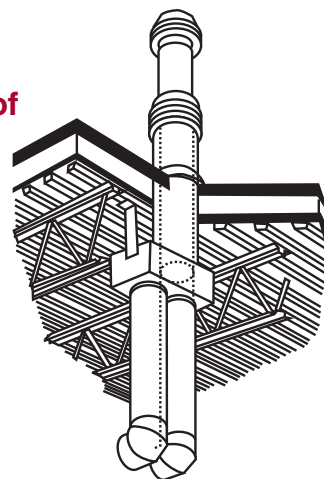

Pipe Diameter and Maximum Pipe Length from Heater to Concentric Adapter

Model	Size	Pipe Diameter				Maximum Pipe Length		Equivalent Straight Length for			
		Vent Pipe		Inlet Air Pipe		feet	M	90° Elbow		45° Elbow	
		inches	mm	inches	mm			feet	M	feet	M
UDAS/ UDBS	30	3	76	3	76	15	4.6	2	0.6	1	0.3
	45	3	76	3	76	15	4.6	2	0.6	1	0.3
	60	3	76	3	76	25	7.6	3	0.9	1.5	0.5
	75	4	102	4	102	25	7.6	3	0.9	1.5	0.5
	100	4	102	4	102	35	10.7	4	1.2	2	0.6
	125	4	102	4	102	35	10.7	4	1.2	2	0.6
	150	5	127	6	152	30	9.1	3	0.9	1.5	0.5
	175	5	127	6	152	30	9.1	3	0.9	2	0.6
	200	5	127	6	152	40	12.2	4	1.2	2	0.6
	225	5	127	6	152	40	12.2	4	1.2	2	0.6
	250	5	127	6	152	40	12.2	4	1.2	2	0.6
	300	6	152	6	152	45	13.7	4	1.2	2	0.6
SHE	225	4	102	4	102	27	8.2	5	1.5	3.5	1.1
	300	6	152	6	152	30	9.1	5	1.5	3.5	1.1
	400	6	152	6	152	30	9.1	5	1.5	3.5	1.1

REZNOR®

Venting/Inlet Air for Separated Combustion Models (cont'd)

Side View of a Horizontal Vent/Combustion Air System for a Separated Combustion Unit

A horizontal vent/combustion air kit is identified as Option CC6.

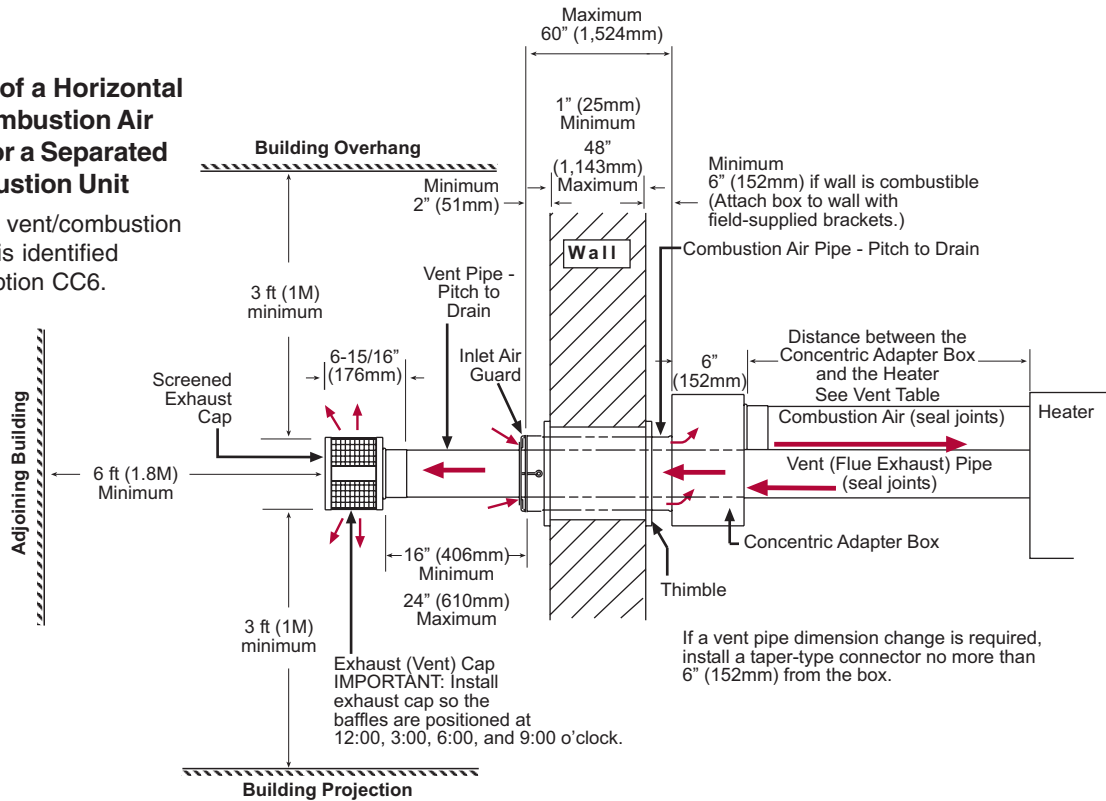

Side View of a Vertical Vent/Combustion Air System for a Separated Combustion Unit

A vertical vent/combustion air kit is identified as Option CC2.

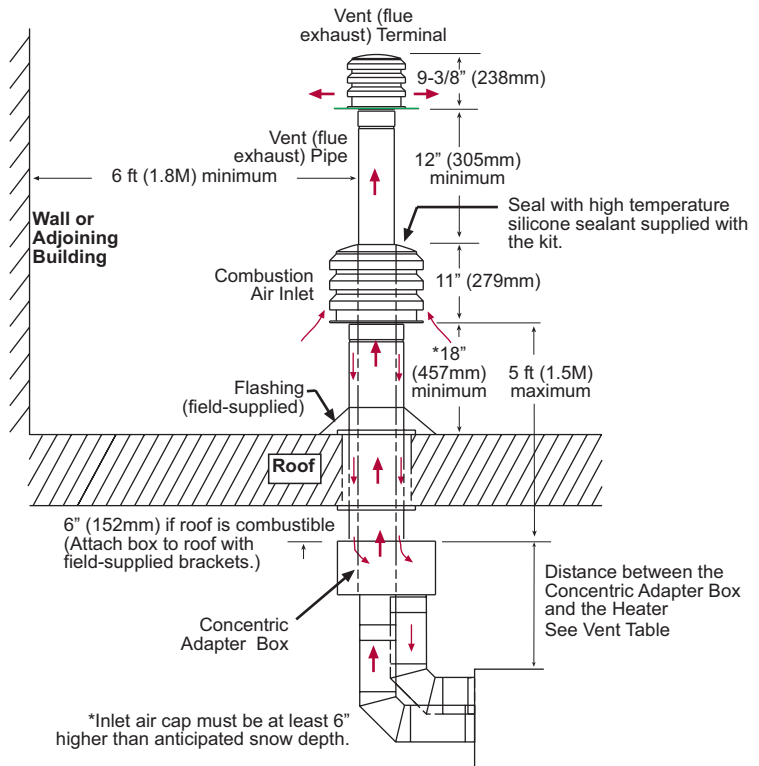

Sizes 30, 45, 60, 300, 350, and 400, install a taper-type connector no more than 6" (152mm) from the box.



Pilot, Gas Control, and Air Control Descriptions Gas-Fired Unit Heaters

PILOT IGNITION SYSTEMS

- Manual Pilot: Manual match lit pilots with 100% shutoff, pilot remains on 100% of time until pilot gas flow is shut off (**Models F & B Only**).
- Intermittent Spark Pilot: Automatic lighting of pilot with an electronic spark on a call for heat. Pilot gas flow is shutoff between heat cycles. Approved for use in the United States with the natural gas supply only on indoor and outdoor units (**Models F & B Only**).
- Intermittent Spark Pilot with Timed Lockout: Automatic lighting of pilot with an electronic spark on a call for heat. Pilot gas flow is shutoff between heating cycles. Locked device stops gas flow to the pilot if the pilot fails to light in 120 seconds. Reset of lockout requires manual interruption of the thermostat circuit. Approved for use in the United States and Canada with natural or propane gas on indoor and outdoor applications (**Models F & B Only**).
- Direct Spark Ignition with Timed Lockout: Automatic lighting of the burner with an electronic spark on a call for heat by the thermostat. There is no pilot. Trial for ignition is ten seconds after which, if flame is not sensed, the unit tries for ignition again. If ignition is not proven after three attempts the unit will lockout and then automatically retry after a one hour down period (**Models UDAP, UDAS, UDBP & UDBS Only**).

GAS CONTROL SYSTEMS

- Single Stage: Single-stage gas valve which cycles on at 100% fire on a call for heat.
- Two-Stage: Two stage gas valve which fires at 100% or 50% on Models F & B; 100% or 70% on Models UDAP, UDAS, UDBP & UDBS, as required by a remote two-stage thermostat. (**Note: Two-Stage gas valve not available on Models F & B [sizes 25 & 50 MBH] or Models UDAP, UDAS, UDBP & UDBS [sizes 30 & 45 MBH]**)

AIR CONTROL SYSTEMS

- Air Recirculation Kit (Single-stage units only): First stage control of thermostat energizes unit fan to recirculate warm stratified ceiling air. Second stage control of thermostat opens single-stage gas valve.
- Special Air Recirculation Kit (Single-stage units only): Same as the basic kit, with the addition of a manual summer switch on thermostat for summer fan operation.

Options and Accessories

Apply to Unit Heater Models as Listed

■ Optional Stepdown Transformers - Apply to Models F and B

Model	Unit Size							
	25	50	75	100	125-200	250	300	400
F (heater only)	.25	.25	.25	.50	.50	.50	.50	1.00
F with Field-installed Optional Venter	.25	.50	.50	.50	.75	.50	.75	1.00
B (heater only)	.50	.50	1.0	1.0				
B with Field-installed Optional Venter	.50	.50	1.0	1.0				



Options and Accessories (cont'd)

Apply to Unit Heater Models as Listed

Optional Polytube Outlet Adapter - Apply to Models UDBP/UDBS

Description

The optional polytube adapter is designed to adapt suspended Model UDBP and UDBS blower type unit heaters for use with polytube ductwork. Directly in line with the heater discharge, the adapter is installed on the front of the heater and is equipped with a collar for attaching the field-supplied polytube.

The most common application of polytube ductwork for distribution of tempered air is in greenhouses. Polytubes are also used in industrial buildings to improve operating efficiency by recovering stratified air and reducing the need for complete area heating.

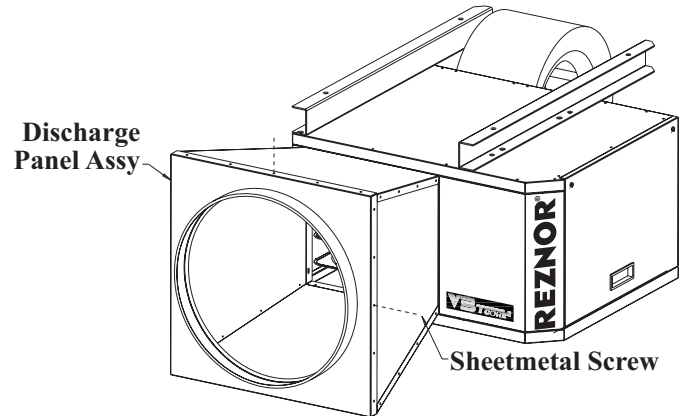

Size	CFM at 60°F Temp Rise	Polytube Diameter (inches)	Approximate Free Area (square inches)	Suggested Hole Sizes and Locations					
				Holes	Length of Polytube				
					50 Ft	75 Ft	100 Ft	125 Ft	150 Ft
75*	960	18	115	Quantity	75 pairs	75 pairs	75 pairs	75 pairs	75 pairs
				Diameter (inches)	1	1	1	1	1
				Spacing (inches)	8	12	16	20	24
100*	1345	18	160	Quantity	48 pairs	48 pairs	48 pairs	48 pairs	48 pairs
				Diameter (inches)	1 1/2	1 1/2	1 1/2	1 1/2	1 1/2
				Spacing (inches)	12 1/2	18 3/4	25	31 1/4	37 1/2
125*	1540	18	185	Quantity	50 pairs	50 pairs	50 pairs	50 pairs	50 pairs
				Diameter (inches)	1 1/2	1 1/2	1 1/2	1 1/2	1 1/2
				Spacing (inches)	12	18	24	30	36
150	1920	24	230	Quantity	40 pairs	40 pairs	40 pairs	40 pairs	45 pairs
				Diameter (inches)	2	2	2	2	1 7/8
				Spacing (inches)	15	22 1/2	30	37 1/2	40
175	2240	24	270	Quantity	50 pairs	50 pairs	80 pairs	80 pairs	80 pairs
				Diameter (inches)	1 7/8	1 7/8	1 1/2	1 1/2	1 1/2
				Spacing (inches)	12	18	15	18 3/4	22 1/2
200	2560	24	300	Quantity	50 pairs	50 pairs	50 pairs	50 pairs	50 pairs
				Diameter (inches)	2	2	2	2	2
				Spacing (inches)	12	18	24	30	36
225	2880	24	340	Quantity	42 pairs	42 pairs	42 pairs	42 pairs	42 pairs
				Diameter (inches)	2 1/4	2 1/4	2 1/4	2 1/4	2 1/4
				Spacing (inches)	14	21	28	35	42
250	3200	24	380	Quantity	50 pairs	50 pairs	50 pairs	60 pairs	60 pairs
				Diameter (inches)	2 1/4	2 1/4	2 1/4	2	2
				Spacing (inches)	12	18	24	25	30
300	3840	24	460	Quantity	60 pairs	60 pairs	75 pairs	75 pairs	75 pairs
				Diameter (inches)	2 1/4	2 1/4	2	2	2
				Spacing (inches)	10	15	16	20	24
350	4480	24	540	Quantity	50 pairs	50 pairs	50 pairs	50 pairs	50 pairs
				Diameter (inches)	2 1/2	2 1/2	2 1/2	2 1/2	2 1/2
				Spacing (inches)	12	18	24	30	36
400	5120	24	600	Quantity	60 pairs	60 pairs	75 pairs	75 pairs	75 pairs
				Diameter (inches)	2 1/2	2 1/2	2 1/4	2 1/4	2 1/4
				Spacing (inches)	10	15	16	20	24

* Required direct drive blower speed.

Size	Speed
75	Low
100	Low
125	Medium



Options and Accessories (cont'd)

Apply to Unit Heater Models as Listed

Optional Polytube Outlet Adapter - Apply to Model B

Description

The optional outlet nozzle is designed to allow the attachment of polytube-type air distribution for use in greenhouse and industrial buildings. Outlet on suspended heater may be either above, below, or directly in line with the heater discharge. A kit is available to floor mount the heater with outlet below the heater discharge (see illustration). Model B standard blower and drive are designed to handle rated CFM at .25 w.c. ESP, and will inflate a 24" tube up to 150 ft long. See table for proper free area, minimum number of holes and sizes. Units may be used for greenhouse heating and ventilating or in industrial applications requiring high mounting heights or spot heating by means of polytube distribution.

The total open or free area of the polytube is important. Polytube suppliers have a great deal of flexibility in placement and sizing of holes. Too small of a free area will cause overheating. Excessive open area may not permit the tube to inflate. See the table below for a guide in hole size and location. Spacing and hole size may be varied, but free area must not be less than shown for the heater being installed.

Greenhouse Application - For greenhouse use, the number of units required is generally based on an airflow volume of 1-1/2 to 2 CFM per square foot of house floor area. Depending on the heat loss requirements of the house type, location, and desired temperature above ambient, the ventilation requirements determine the number of distribution systems required and the heat loss determines the BTUH heater size required. As a general rule, a single system will serve a maximum house width of 30 ft and a length of 150 ft.

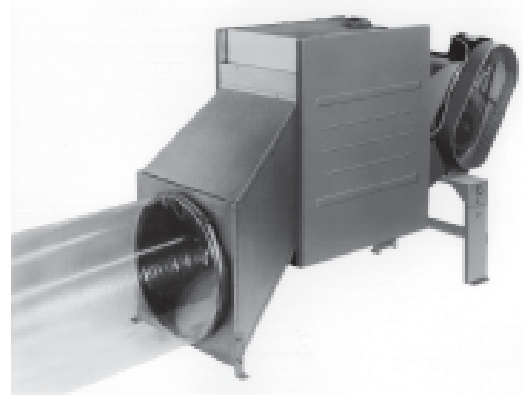

Photograph shows polytube outlet. The outlet nozzle requires field assembly and installation on the standard unit in place of the top front panel and louvers. The heater manufacturer does not supply tubing.

Tubing can be ordered from a local greenhouse supply distributor. Two such suppliers are FOF Products, Inc. P. O. Box E, 1505 Racine Street, Delevan, WI 53115 and ACME Engineering Co., P. O. Box 978, Muskogee, OK 74402.

Size	CFM at .25" ESP	Polytube Diameter (inches)	Minimum Free Area (square Inches)	Suggested Hole Sizes and Locations						
				Holes	Length of Polytube					
					50 Ft	75 Ft	100 Ft	125 Ft	150 Ft	
75	925	18	110	Number	37pairs	75 pairs	75 pairs			
				Diameter	1-1/2"	1"	1"			
				Spacing	16"	12"	16"			
100	1235	18	145	Number	50 pairs	50 pairs	100 pairs	94 pairs		
				Diameter	1-1/2"	1-1/2"	1"	1"		
				Spacing	12"	18"	12"	16"		
125	1540	18	185	Number	40 pairs	60 pairs	60 pairs	125 pairs		
				Diameter	1-7/8"	1-1/2"	1-1/2"	1"		
				Spacing	15"	15"	20"	12"		
130	1600	24	190	Number	40 pairs	60 pairs	60 pairs	125 pairs		
				Diameter	1-7/8"	1-1/2"	1-1/2"	1"		
				Spacing	15"	15"	20"	12"		
165	2035	24	240	Number	50 pairs	50 pairs	75 pairs	75 pairs	75 pairs	
				Diameter	1-7/8"	1-7/8"	1-1/2"	1-1/2"	1-1/2"	
				Spacing	12"	18"	16"	20"	24"	
200	2465	24	300	Number	42 pairs	42 pairs	60 pairs	60 pairs	100 pairs	
				Diameter	2-1/4"	2-1/4"	1-7/8"	1-7/8"	1-1/2"	
				Spacing	14"	21"	20"	25"	18"	
250	3085	24	360	Number	40 pairs	60 pairs	60 pairs	60 pairs	60 pairs	
				Diameter	2-1/2"	2"	2"	2"	2"	
				Spacing	15"	15"	20"	25"	30"	
300	3700	24	425	Number	75 pairs	75 pairs	75 pairs	75 pairs	75 pairs	
				Diameter	2"	2"	2"	2"	2"	
				Spacing	9"	12"	16"	20"	24"	
400	4935	24	550	Number	60 pairs	60 pairs	60 pairs	100 pairs	100 pairs	
				Diameter	2-1/2"	2-1/2"	2-1/2"	1-7/8"	1-7/8"	
				Spacing	10"	15"	20"	15"	18"	

CAUTION: To prevent overheating of the blower unit heater and to ensure correct air distribution, the minimum hole area must be provided as shown in the table for each size. If more holes are used, do not exceed 1.25 times the minimum area shown to ensure proper tube inflation.

Diameter of the Hole (inches)	Area of the Hole (square inches)
2-1/2	4.91
2-1/4	3.98
2	3.14
1-7/8	2.76
1-1/2	1.76
1	0.785

Optional Downturn Nozzles - Apply to Models UDAP, UDAS, UDBP, UDBS, F and B

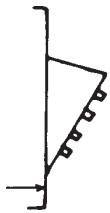

Optional Downturn Nozzle with 25°-65° Range of Air Deflection

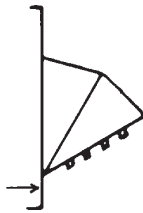

Optional Downturn Nozzle with 50°-90° Range of Air Deflection

IMPORTANT: On fan Models UDAP, UDAS and F, *do not* use optional vertical louvers in combination with a nozzle with 50-90° range of air deflection.

- Shipped separately for field assembly and installation

Model OT Oil Tank - Apply to Models OH and OB

DESCRIPTION

The Model OT250 fuel tank is a 250-gallon, single-wall, indoor, UL-listed fuel oil tank. Oil tanks often eliminate needed work and storage space, but the Model OT-250 oil tank is designed with a work bench top that allows the tank itself to be used as a work area. The tank has a large (12-1/2 sq ft) work surface with 2" side and rear retainer lips and 3" legs for "toe space".

Tank construction is of 12-gauge carbon steel with all welded seams. The painted exterior coordinates with Reznor® oil-fired heaters.

The Reznor® OT-250 fuel tank is also engineered to facilitate installation. The support legs provide convenient space for forklift handling. Each tank has the following connection ports -- 2" supply; 2" gauge; 2" vent; 4" emergency vent; and 1" drain. Each port has heavy duty forged threads.

Model OT-250 tank is UL listed to UL142 Standard.

OPTIONS/ACCESSORIES - Field Installed

- Heater stand for Model OT tank used with Model OH heater only

DIMENSIONS - Model OT Fuel Tank

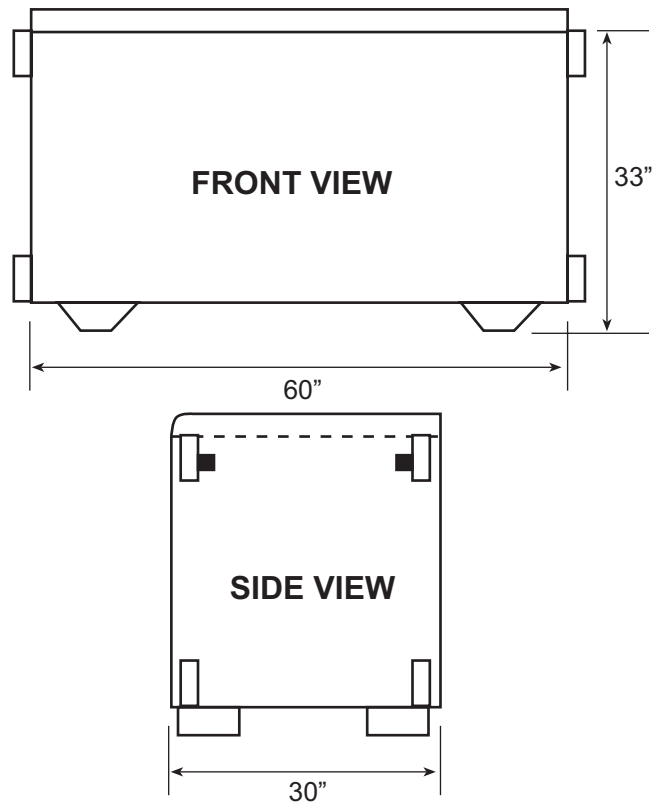

Model OH Oil Heater

Heater Stand (Option ST1)

Model OT-250 Oil Tank



Port Locations

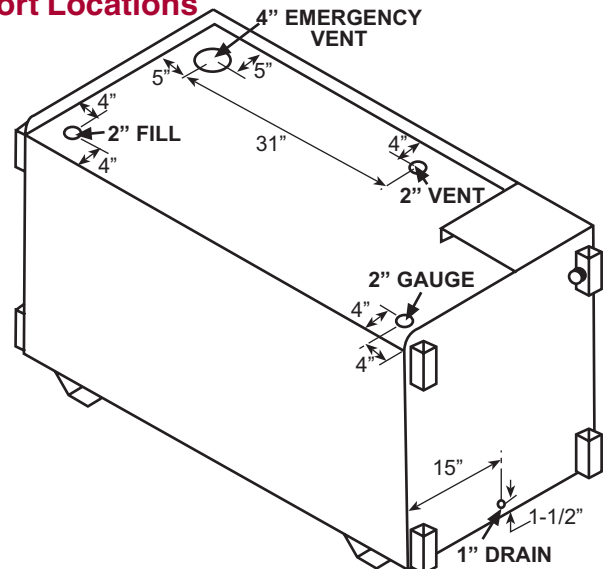

REZNOR® Sample Specifications (cont'd)

GAS-FIRED, SEPARATED COMBUSTION UNIT HEATERS

Provide (82%, 83%) high-efficiency, separated-combustion, power vented, gas-fired unit heaters manufactured as Reznor® brand units. The unit shall be designed for use in a building with negative pressures up to 0.15 " w.c. and for use in building where a non-explosive atmosphere exist that is dust laden and/or contains mildly corrosive fumes.

Model UDAS

Each of the 14 sizes in the Model UDAS series shall be equipped for use with (natural) (propane) gas. Gas connection shall be external to the cabinet.

Heat Exchanger

The heater shall be equipped with a multicell, 4 pass serpentine style steel heat exchanger. Heat exchanger tubes shall be press fabricated of (titanium stabilized, corrosion resistant aluminized steel) (409 stainless steel) (316 stainless steel). All heat exchangers shall be fabricated with no welding or brazing, only tool pressed mechanical joints. All heat exchanger cells shall be designed with an aerodynamic cross section to provide maximum airflow.

Burner

The units shall incorporate a single, one piece burner assembly with a single orifice. The burner shall have a continuous wound close pressed stainless steel ribbon separating the flame from the burner interior. All units shall have a single venturi tube and orifice supplying fuel to a one-piece burner housing. Each heat exchanger cell shall use balanced draft induction to maintain optimum flame control.

Controls

Controls shall include a (single-stage) (two-stage) gas valve; direct spark multi-try ignition with electronic flame supervision with 100% lockout integrally controlled via a printed circuit control board. The control board shall also incorporate diagnostic lights, DIP switches for fan overrun settings, and a relay for fan only operation. All units shall be equipped with a safety limit switch.

All controls shall be enclosed in the sealed control compartment to protect them from accidental damage, dust, and atmospheric corrosion.

Combustion Air and Venting

The unit shall have a factory-installed power venter device to draw combustion air from outside of the building. The outside air shall enter the unit through a factory-installed round inlet air terminal on the rear of the heater. The control compartment shall be sealed and the access door shall be gasketed to prevent dirt, lint, dust, or other contaminants present in the heated space from entering the unit. The control compartment door shall be equipped with a safety interlock switch to prevent operation when the door is open.

The combustion air supply pipe and flue exhaust pipe shall be run in parallel from the heater to a factory supplied concentric adapter assembly, which allows for a single wall or roof penetration, to the (horizontal) (vertical) air inlet and vent terminal.

The combustion air/venting system shall include a vibration isolated power venter motor and wheel assembly and a combustion air pressure switch. Unit Sizes 30-125 shall include a flame rollout switch.

Electrical

Operation shall be controlled by an integrated circuit board that includes LED diagnostic indicator lights. Supply voltage connections shall be made in a sealed junction box. 24-volt control connections shall be made on an externally mounted terminal strip with connections (W1, W2, R, and G). All internal wiring, both line and control voltages, shall be terminated by insulated terminal connectors to minimize shock hazard during service.

Each unit shall be equipped for use with (115/1) (208/1) (230/1) volt power supply. (Stepdown transformers shall be available to be field installed for use with (230/3) (460/3) volt power supply.)

All units will be equipped with a built-in disconnect switch.

Cabinet

The cabinet shall be low profile with a pre-coat or powdercoat RAL 1001 white paint finish. Finish shall be a minimum 80 gloss on G30 galvanized steel. The cabinet shall be constructed so that screws are not visible from the bottom, front, or sides, except for service panel and accessories. Unit construction shall incorporate a beveled front corner on control side for additional cabinet rigidity. All units shall be manufactured with a tooled drawn supply air orifice on the rear panel to reduce fan inlet noise.

The unit shall be designed for ceiling suspension featuring 3/8"-16 female threads (hanger kits for 1" pipe) at both 2-point and 4-point locations with no additional adapter kits. (Hanger kit for ceiling mounting shall be available for Sizes 30-125.)

The cabinet shall be equipped with RAL 3005 burgundy painted, roll-formed horizontal louvers. Louvers shall be spring held and adjustable for directing airflow. (Vertical louvers) (downturn nozzles) (downturn nozzles with vertical louvers) shall be available.

The cabinet shall be equipped with a full safety fan guard with no more than 1/2 inch grill spacing on Sizes 30-125 or no more than 1 inch on Sizes 150-400. The (open dripproof) (enclosed) motor and fan assembly shall be resiliently mounted to the cabinet to reduce vibration and noise.

The unit shall be designed with a full opening service access panel complete with screw closure attachment and lifting handle for removal. Service panel shall be fully gasketed and equipped with a safety interlock switch. All components in the gas train, all standard electrical controls, and the power venter shall be within the sealed service compartment.

Minimum top clearance from combustibles shall be 1" for Sizes 30-125 and 4" for Sizes 150-400. Minimum bottom clearance from combustibles shall be 1" for all sizes. Minimum clearance from combustibles on non-service side shall be 1" for Sizes 30-125 and 2" for Sizes 150-400.

Certifications

Model sizes 30, 45, 60, 75, 100 and 125 MBH shall be certified to CSA International Requirement 10-96 U.S. for RESIDENTIAL INSTALLATION. All sizes shall be design certified by the Canadian Standards Association to ANSI Z83.8b and CSA 2.6b for commercial/industrial installation.

Units shall be manufactured in an ISO 9002 certified facility. Manufacturer must have a minimum of 50 years experience in the manufacture of gas fired unit heaters.

REZNOR® Sample Specifications (cont'd)

GAS-FIRED, SEPARATED COMBUSTION HIGH STATIC UNIT HEATERS

Provide (82%, 83%) high-efficiency, separated-combustion, power vented, gas-fired unit heaters manufactured as Reznor® brand units. The unit shall be designed for use in a building with negative pressures up to 0.15 " w.c. and for use in building where a non-explosive atmosphere exist that is dust laden and/or contains mildly corrosive fumes.

Model UDBS

Each of the 14 sizes in the Model UDBS series shall be equipped for use with (natural) (propane) gas. Gas connection shall be external to the cabinet.

Heat Exchanger

The heater shall be equipped with a multicell, 4 pass serpentine style steel heat exchanger. Heat exchanger tubes shall be press fabricated of (titanium stabilized, corrosion resistant aluminized steel) (409 stainless steel) (316 stainless steel). All heat exchangers shall be fabricated with no welding or brazing, only tool pressed mechanical joints. All heat exchanger cells shall be designed with an aerodynamic cross section to provide maximum airflow.

Burner

The units shall incorporate a single, one piece burner assembly with a single orifice. The burner shall have a continuous wound close pressed stainless steel ribbon separating the flame from the burner interior. All units shall have a single venturi tube and orifice supplying fuel to a one-piece burner housing. Each heat exchanger cell shall use balanced draft induction to maintain optimum flame control.

Controls

Controls shall include a (single-stage) (two-stage) gas valve; direct spark multi-try ignition with electronic flame supervision with 100% lockout integrally controlled via a printed circuit control board. The control board shall also incorporate diagnostic lights, DIP switches for blower overrun settings, and a relay (definite purpose 3 pole contactor) for blower only operation. All open (TEFC) blower motors shall have automatic thermal overload protection or be equipped with a factory installed motor starter with adjustable thermal overloads. All units shall be equipped with a safety limit switch.

All controls shall be enclosed in the sealed control compartment to protect them from accidental damage, dust, and atmospheric corrosion.

Combustion Air and Venting

The unit shall have a factory-installed power venter device to draw combustion air from outside of the building. The outside air shall enter the unit through a factory-installed round inlet air terminal on the rear of the heater. The control compartment shall be sealed and the access door shall be gasketed to prevent dirt, lint, dust, or other contaminants present in the heated space from entering the unit. The control compartment door shall be equipped with a safety interlock switch to prevent operation when the door is open.

The combustion air supply pipe and flue exhaust pipe shall be run in parallel from the heater to a factory supplied concentric adapter assembly, which allows for a single wall or roof penetration, to the (horizontal) (vertical) air inlet and vent terminal.

The combustion air/venting system shall include a vibration isolated power venter motor and wheel assembly and a combustion air pressure switch.

Electrical

Operation shall be controlled by an integrated circuit board that includes LED diagnostic indicator lights. Supply voltage connections shall be made in a sealed junction box. 24-volt control connections shall be made on an externally mounted terminal strip with connections W1, W2, R, and G. All internal wiring, both line and control voltages, shall be terminated by insulated terminal connectors to minimize shock hazard during service.

Size 30,000 to 125,000 BTUH units shall be equipped with a 115V power supply (Stepdown transformers shall be available to be field installed for use with a (230) (460) volt power supply.)

Size 150,000 to 400,000 BTUH units shall be equipped for use with 115/1 (208/1) (230/1) (208/3) (230/3) (460/3) (575/3) volt power supply.

All units will be equipped with a suitably rated, factory installed built-in disconnect switch.

Blower

Size 30,000-125,000 BTUH units shall be equipped with a centrifugal blower with direct drive from an open dripproof motor with internal overloads. Size 30,000 and 45,000 BTUH units must be able to handle .5" w.c. of external static pressure. Size 60,000-125,000 BTUH units must be able to handle .75" w.c. of external static pressure. (Size 30,000-125,000 BTUH units may be equipped with a blower inlet guard.)

Size 150,000-400,000 BTUH units shall be equipped with a centrifugal blower and adjustable belt drive and an (open dripproof) (totally enclosed) blower motor with internal overloads. Size 150,000-400,000 BTUH units must be able to handle .5" w.c. of external static pressure. (Size 150,000-400,000 BTUH units may be equipped with an OSHA-type belt guard and blower inlet guard.)

Cabinet

The cabinet shall be low profile with a pre-coat or powdercoat RAL 1001 white paint finish. Finish shall be a minimum 80 gloss on G30 galvanized steel. The heat exchanger/control compartment cabinet shall be constructed so that screws are not visible from the bottom, front, or sides, except for service panel and accessories. Cabinet shall have a beveled front corner on the control side for additional cabinet rigidity.

The unit shall be designed for ceiling suspension featuring 3/8"-16 female threads (hanger kits for 1" pipe) at 4-point locations.

The cabinet shall be equipped with RAL 3005 burgundy painted, roll-formed horizontal louvers (duct flange). Louvers shall be spring held and adjustable for directing airflow. (Vertical louvers) (downturn nozzles) (downturn nozzles with vertical louvers) shall be available.

The unit shall be designed with a full opening service access panel complete with captive screw closure attachment and lifting handle for removal. Service panel shall be fully gasketed and equipped with a safety interlock switch. All components in the gas train, all standard electrical controls, and the power venter shall be within the sealed service compartment.

Minimum **top** clearance from combustibles shall be 6" (152mm) for Size 30,000-125,000 BTUH units and 14" (356mm) for Size 150,000-400,000 BTUH units. Minimum **bottom** clearance from combustibles shall be 1" (25mm) for all size units. Minimum clearance on **access side** shall be 18" (457mm) for all sizes. Minimum clearance on **non-access side** shall be 24" (610mm) for all sizes. Minimum **rear** clearance for all sizes is 18" (457mm).

Certifications

All sizes shall be design certified by the Canadian Standards Association to ANSI Z83.8 and CSA 2.6 for commercial/industrial installation.

Units shall be manufactured in an ISO 9001 certified facility. Manufacturer must have a minimum of 50 years experience in the manufacture of gas fired unit heaters.

GAS-FIRED, POWER VENTED UNIT HEATERS

Provide (82%, 83%) high-efficiency, power vented, gas-fired unit heaters manufactured as Reznor® brand units designed for use in building areas where higher reliability is required and venting is either vertical or horizontal.

Model UDAP

Each of the 14 sizes in the Model UDAP series shall be equipped for use with (natural) (propane) gas. Gas connection shall be external to the cabinet.

Heat Exchanger

The heater shall be equipped with a multicell, 4 pass serpentine style steel heat exchanger. Heat exchanger tubes shall be press fabricated of (titanium stabilized, corrosion resistant aluminized steel) (409 stainless steel) (316 stainless steel). All heat exchangers shall be fabricated with no welding or brazing, only tool pressed mechanical joints. All heat exchanger cells shall be designed with an aerodynamic cross section to provide maximum airflow.

Burner

The units shall incorporate a single, one piece burner assembly with a single orifice. The burner shall have a continuous wound close pressed stainless steel ribbon separating the flame from the burner interior. All units shall have a single venturi tube and orifice supplying fuel to a one-piece burner housing. Each heat exchanger cell shall use balanced draft induction to maintain optimum flame control.

Controls

Controls shall include a (single-stage) (two-stage) gas valve; direct spark multi-try ignition with electronic flame supervision with 100% lockout integrally controlled via a printed circuit control board. The control board shall also incorporate diagnostic lights, DIP switches for fan overrun settings, and a relay for fan only operation. All units shall be equipped with a safety limit switch.

All controls shall be enclosed in the unit housing to protect them from accidental damage that could be caused by factors in the building that would adversely affect external controls.

Combustion Air and Venting

The unit shall have a factory-installed power venter device to draw combustion air through an inlet in the rear of the cabinet.

The combustion air/venting system shall include a vibration isolated power venter motor and wheel assembly and a combustion air pressure switch. Unit Sizes 30-125 shall include a flame rollout switch. (The unit shall be equipped with an approved common vent option to allow venting with another gravity vented Category I gas appliance).

(A vent cap shall be available.)

Electrical

Operation shall be controlled by an integrated circuit board that includes LED diagnostic indicator lights. Supply voltage connections are made at the circuit board. 24-volt control connections shall be made on an externally mounted terminal strip with connections (W1, W2, R, and G). All internal wiring, both line and control voltages, shall be terminated by insulated terminal connectors to minimize shock hazard during service.

Each unit shall be equipped for use with (115/1) (208/1) (230/1) volt power supply. (Stepdown transformers shall be available to be field installed for use with (230/3) (460/3) volt power supply.)

Cabinet

The cabinet shall be low profile with a pre-coat or powdercoat RAL 1001 white paint finish. Finish shall be a minimum 80 gloss on G30 galvanized steel. The cabinet shall be constructed so that screws are not visible from the bottom, front, or sides, except for service panel and accessories. Unit construction shall incorporate a beveled front corner on control side for additional cabinet rigidity. All units shall be manufactured with a tooled drawn supply air orifice on the rear panel to reduce fan inlet noise.

The unit shall be designed for ceiling suspension featuring 3/8"-16 female threads (hanger kits for 1" pipe) at both 2-point and 4-point locations with no additional adapter kits. (Hanger kit for ceiling mounting shall be available for Sizes 30-125.)

The cabinet shall be equipped with RAL 3005 burgundy painted, roll-formed horizontal louvers. Louvers shall be spring held and adjustable for directing airflow. (Vertical louvers) (downturn nozzles) (downturn nozzles with vertical louvers) shall be available.

The cabinet shall be equipped with a full safety fan guard with no more than 1/2 inch grill spacing on Sizes 30-125 or no more than 1 inch on Sizes 150-400. The (open dripproof) (enclosed) motor and fan assembly shall be resiliently mounted to the cabinet to reduce vibration and noise.

The unit shall be designed with a full opening service access panel complete with screw closure attachment and lifting handle for removal. All components in the gas train, all standard electrical controls, and the power venter shall be within the service compartment.

Minimum top clearance from combustibles shall be 1" for Sizes 30-125 and 4" for Sizes 150-400. Minimum bottom clearance from combustibles shall be 1" for all sizes. Minimum clearance from combustibles on non-service side shall be 1" for Sizes 30-125 and 2" for Sizes 150-400.

Certifications

Model sizes 30, 45, 60, 75, 100 and 125 MBH shall be certified to CSA International Requirement 10-96 U.S. for RESIDENTIAL INSTALLATION. All sizes shall be design certified by the Canadian Standards Association to ANSI Z83.8b and CSA 2.6b for commercial/industrial installation.

Units shall be manufactured in an ISO 9002 certified facility. Manufacturer must have a minimum of 50 years experience in the manufacture of gas fired unit heaters.

REZNOR® Sample Specifications (cont'd)

GAS-FIRED, POWER VENTED HIGH STATIC UNIT HEATERS

Provide (82%, 83%) high-efficiency, power vented, gas-fired unit heaters manufactured as Reznor® brand units designed for use in building areas where higher reliability is required and venting is either vertical or horizontal.

Model UDBP

Each of the 14 sizes in the Model UDBP series shall be equipped for use with (natural) (propane) gas. Gas connection shall be external to the cabinet.

Heat Exchanger

The heater shall be equipped with a multicell, 4 pass serpentine style steel heat exchanger. Heat exchanger tubes shall be press fabricated of (titanium stabilized, corrosion resistant aluminized steel) (409 stainless steel) (316 stainless steel). All heat exchangers shall be fabricated with no welding or brazing, only tool pressed mechanical joints. All heat exchanger cells shall be designed with an aerodynamic cross section to provide maximum airflow.

Burner

The units shall incorporate a single, one piece burner assembly with a single orifice. The burner shall have a continuous wound close pressed stainless steel ribbon separating the flame from the burner interior. All units shall have a single venturi tube and orifice supplying fuel to a one-piece burner housing. Each heat exchanger cell shall use balanced draft induction to maintain optimum flame control.

Controls

Controls shall include a (single-stage) (two-stage) gas valve; direct spark multi-try ignition with electronic flame supervision with 100% lockout integrally controlled via a printed circuit control board. The control board shall also incorporate diagnostic lights, DIP switches for blower overrun settings, and a relay (definite purpose 3 pole contactor) for blower only operation. All open (TEFC) blower motors shall have automatic thermal overload protection or be equipped with a factory installed motor starter with adjustable thermal overloads. All units shall be equipped with a safety limit switch.

All controls shall be enclosed in the sealed control compartment to protect them from accidental damage, dust, and atmospheric corrosion.

Combustion Air and Venting

The unit shall have a factory-installed power venter device to draw combustion air through an inlet in the rear of the cabinet.

The combustion air/venting system shall include a vibration isolated power venter motor and wheel assembly and a combustion air pressure switch.

(An approved vent cap shall be available.)

Electrical

Operation shall be controlled by an integrated circuit board that includes LED diagnostic indicator lights. Supply voltage connections are made at the circuit board. 24-volt control connections shall be made on an externally mounted terminal strip with connections W1, W2, R, and G. All internal wiring, both line and control voltages, shall be terminated by insulated terminal connectors to minimize shock hazard during service.

Size 30,000 to 125,000 BTUH units shall be equipped with a 115V power supply (Stepdown transformers shall be available to be field installed for use with a (230) (460) volt power supply.)

Size 150,00 to 400,000 BTUH units shall be equipped for use with 115/1 (208/1) (230/1) (208/3) (230/3) (460/3) (575/3) volt power supply.

Blower

Size 30,000-125,000 BTUH units shall be equipped with a centrifugal blower with direct drive from an open dripproof motor with internal overloads. Size 30,000 and 45,000 BTUH units must be able to handle .5" w.c. of external static pressure. Size 60,000-125,000 BTUH units must be able to handle .75" w.c. of external static pressure. (Size 30,000-125,000 BTUH units may be equipped with a blower inlet guard.)

Size 150,000-400,000 BTUH units shall be equipped with a centrifugal blower and adjustable belt drive and an (open dripproof) (totally enclosed) blower motor with internal overloads. Size 150,000-400,000 BTUH units must be able to overcome .5" w.c. of external static pressure. (Size 150,000-400,000 BTUH units may be equipped with an OSHA-type belt guard and blower inlet guard.)

Cabinet

The cabinet shall be low profile with a pre-coat or powdercoat RAL 1001 white paint finish. Finish shall be a minimum 80 gloss on G30 galvanized steel. The heat exchanger/control compartment cabinet shall be constructed so that screws are not visible from the bottom, front, or sides, except for service panel and accessories. Cabinet shall have a beveled front corner on the control side for additional cabinet rigidity.

The unit shall be designed for ceiling suspension featuring 3/8"-16 female threads (hanger kits for 1" pipe) at 4-point locations.

The cabinet shall be equipped with RAL 3005 burgundy painted, roll-formed horizontal louvers (duct flange). Louvers shall be spring held and adjustable for directing airflow. (Vertical louvers) (downturn nozzles) (downturn nozzles with vertical louvers) shall be available.

The unit shall be designed with a full opening service access panel complete with captive screw closure attachment and lifting handle for removal. All components in the gas train, all standard electrical controls, and the power venter shall be within the service compartment.

Minimum **top** clearance from combustibles shall be 6" (152mm) for Size 30,000-125,000 BTUH units and 14" (356mm) for Size 150,000-400,000 BTUH units. Minimum **bottom** clearance from combustibles shall be 1" (25mm) for all size units. Minimum clearance on **access side** shall be 18" (457mm) for all sizes. Minimum clearance on **non-access side** shall be 24" (610mm) for all sizes. Minimum **rear** clearance for all sizes is 18" (457mm).

Certifications

All sizes shall be design certified by the Canadian Standards Association to ANSI Z83.8 and CSA 2.6 for commercial/industrial installation.

Units shall be manufactured in an ISO 9001 certified facility. Manufacturer must have a minimum of 50 years experience in the manufacture of gas fired unit heaters.

GAS FIRED, HIGH EFFICIENCY, POWER-VENTED

Model SHE - Propeller fan, separated-combustion model, unit heater

Provide high-efficiency - greater than 90% efficient - gas-fired unit heaters manufactured as Reznor® brand units.

Each Model SHE series unit shall be equipped for use with (natural) (propane) gas and 115/1 volt power supply. The heater shall be equipped with an aluminized steel primary heat exchanger and secondary heat exchanger of corrosion resistant alloy. The heater shall be equipped with an aluminized steel burner rack with die-formed burners.

Standard controls include hot surface ignition with 100% lockout, a single-stage combination gas valve, a 115V fan motor with internal overload protection, a power venter motor, a pressure switch to verify vent flow, fan and limit controls, 24-volt control voltage transformer, horizontal flue and combustion air connections, and horizontal condensation drain connection. Supply air to be dispersed through horizontal louvers.

Units are to be provided for field installation with (horizontal) (vertical) vent/combustion air intake concentric adapter/terminal so that only one (wall) (roof) penetration will be necessary.

Model SHE line of heaters is approved for installation in The United States and Canada by the Canadian Standards Association (CSA). Model SHE units are manufactured in an ISO 9001 facility.

GAS-FIRED, GRAVITY-VENTED UNIT HEATERS

Provide gravity-vented, high-efficiency, gas-fired unit heaters manufactured as Reznor® brand units. Units are designed to take combustion air from the indoor space and vent to the outdoors.

Model F - Gas-fired, propeller fan, gravity-vented model

Each Model F series unit shall be equipped for use with (natural) (propane) gas and (120/1/60) (208/1/60) (230/1/60) (220-240/1/50) volt power supply. The heat exchanger shall be aluminized (E-3 stainless) (409 stainless) steel. Die-formed burners shall be of aluminized steel and include flared ports and a stainless steel insert. The units shall be designed to provide 80% thermal efficiency.

Controls include a 24-volt control transformer; single-stage (two-stage) gas control system; a manual match-lit pilot (intermittent spark pilot with electronic flame supervision) (intermittent spark pilot with electronic flame supervision and timed lockout); fan and limit safety controls; an open, drip-proof (totally enclosed) fan motor with internal overloads; and a blocked vent switch system. The cabinet is equipped with a full safety fan guard and horizontal (vertical) louvers (downturn nozzles) for directing airflow. The unit is arranged for ceiling suspension with 2-point (4-point) threaded hanger connections (hanger kits).

Model F unit heaters are design certified to ANSI and CAN/CGA Standards by the Canadian Standards Association for installation in the United States and Canada.

Model B - Gas-fired, blower, gravity-vented model

Each Model B series unit shall be equipped for use with (natural) (propane) gas and (120/1) (230/1) (460/3) (575/3) volt power supply. The heat exchanger shall be aluminized (E-3 stainless) (409 stainless) steel. Die-formed burners shall be of aluminized steel and include flared ports and a stainless steel insert. The units shall be designed to provide 80% thermal efficiency.

Controls include a 24-volt control transformer; single-stage (two-stage) gas control system; manual match-lit pilot (intermittent spark pilot with electronic flame supervision) (intermittent spark pilot with electronic flame supervision and timed lockout); fan and limit safety controls; a centrifugal blower with adjustable belt drive; and an open, drip-proof (totally enclosed) blower motor with internal overloads. Each unit must be able to overcome .25" w.c. (.5" w.c.) of external static pressure (and may be equipped with an OSHA-type belt and/or blower inlet guard). The cabinet is equipped with horizontal (vertical) louvers (downturn nozzles) for directing airflow or with a duct flange. The unit is arranged for ceiling suspension with 4-point threaded hanger connections (hanger kits).

Model B unit heaters are design certified to ANSI and CAN/CGA Standards by the Canadian Standards Association for installation in the United States and Canada.

OIL-FIRED, GRAVITY-VENTED UNIT HEATERS

Provide oil-fired unit heaters manufactured as Reznor® brand units. The units shall be completely packaged and arranged for ceiling suspension with four-point threaded suspension sockets. They shall be equipped for use with #2 oil using a pressure-atomizing gun-type power burner, a single-stage fuel pump, and an electric spark ignition with an automatic cad-cell flame safety system with manual reset.

Heaters are to be equipped with a heavy, 13-gauge combustion chamber and low stress 18-gauge steel heat exchanger. All sizes shall include flame observation port, CO₂ sample port, and service and cleanout access panels.

Each unit is to be equipped with a combination fan and limit switch with manual fan switch for safety and comfort control. The units are to be used with 115-volt supply and have a 24-volt control transformer.

Model OH - Oil-Fired, propeller fan model

Model OH heaters are provided with a propeller fan and a totally enclosed fan motor with internal overloads. Each unit is to be equipped with a burner service tray, an OSHA-type fan guard, and horizontal (vertical) air directional louvers.

Model OH unit heaters are design certified by Underwriters Laboratories (UL) or certified by the Canadian Standards Association (CSA).

Model OB - Oil-Fired, centrifugal blower model

Model OB heaters are provided with a centrifugal blower with an adjustable belt drive and a totally enclosed, split-phase motor with internal overloads. Each unit is to be equipped with a burner service tray, an OSHA-type belt and blower inlet guard, and horizontal (vertical) air directional louvers.

Model OB unit heaters are design certified by Underwriters Laboratories (UL) or certified by the Canadian Standards Association (CSA).

REZNOR®

REZNOR® PRODUCT LIMITED WARRANTY

Thomas & Betts Corporation warrants to the original owner-user that this Reznor product will be free from defects in material or workmanship. This warranty is limited to twelve (12) months from the date of original installation, whether or not actual use begins on that date, or eighteen (18) months from date of shipment by Thomas & Betts Corporation, whichever occurs first.

EXTENDED WARRANTY

Models UDAP, UDAS, UDBP, and UDBS — Extended nine (9)-year, non-prorated warranty on the heat exchanger, burners, and flue collection box assembly. Extended four (4)-year, non-prorated warranty on all electrical and mechanical operating components (with the exception of blower belts on Models UDBP and UDBS).

Models F and B — Extended nine (9)-year, non-prorated warranty on the heat exchanger, burners, draft hood, and flue baffle assembly. Extended four (4)-year, non-prorated warranty on all electrical and mechanical operating components (with the exception of blower belts on Model B).

Model SHE — Extended four (4)-year, non-prorated warranty on the primary heat exchanger. Extended two (2)-year, non-prorated warranty on the secondary heat exchanger and burners.

Models OH and OB — Extended four (4)-year, non-prorated warranty on the heat exchanger and combustion chamber.

Application NOTE: Extended four (4)-year warranty on electrical and mechanical operating components excludes any Reznor® HVAC equipment installed in a corrosive or highly humid atmosphere such as a greenhouse.

LIMITATIONS AND EXCLUSIONS

Thomas & Betts Corporation's obligations under this warranty and the sole remedy for its breach are limited to repair, at its manufacturing facility, of any part or parts of its Reznor products which prove to be defective; or, in its sole discretion, replacement of such products. All returns of defective parts or products must include the product model number and serial number, and must be made through an authorized Reznor distributor or arranged through Reznor Customer Service. Authorized returns must be shipped prepaid. Repaired or replacement parts will be shipped by Thomas & Betts F.O.B. shipping point.

1. The warranty provided herein does not cover charges for labor or other costs incurred in the troubleshooting, repair, removal, installation, service or handling of parts or complete products.
2. All claims under the warranty provided herein must be made within ninety (90) days from the date of discovery of the defect. Failure to notify Thomas & Betts of a warranted defect within ninety (90) days of its discovery voids Thomas & Betts's obligations hereunder.
3. The warranty provided herein shall be void and of no effect in the event that (a) the product has been operated outside its designed output capacity (heating, cooling, airflow); (b) the product has been subjected to misuse, neglect, accident, improper or inadequate maintenance, corrosive environments, environments containing airborne contaminants (silicone, aluminum oxide, etc.), or excessive thermal shock; (c) unauthorized modifications are made to the product; (d) the product is not installed or operated in compliance with the manufacturer's printed instructions; (e) the product is not installed and operated in compliance with applicable building, mechanical, plumbing and electrical codes; or (f) the serial number of the product has been altered, defaced or removed.
4. The warranty provided herein is for repair or replacement only. Thomas & Betts Corporation shall not be liable for any loss, cost, damage, or expense of any kind arising out of a breach of the warranty. Further, Thomas & Betts Corporation shall not be liable for any incidental, consequential, exemplary, special, or punitive damages, nor for any loss of revenue, profit or use, arising out of a breach of this warranty or in connection with the sale, maintenance, use, operation or repair of any Reznor product. In no event will Thomas & Betts be liable for any amount greater than the purchase price of a defective product. The disclaimers of liability included in this paragraph 4 shall remain in effect and shall continue to be enforceable in the event that any remedy herein shall fail of its essential purpose.
5. THIS WARRANTY IS THE SOLE AND EXCLUSIVE WARRANTY FOR REZNOR PRODUCTS, AND IS IN LIEU OF ALL OTHER EXPRESS AND IMPLIED WARRANTIES. THOMAS & BETTS CORPORATION SPECIFICALLY DISCLAIMS ALL OTHER EXPRESS AND IMPLIED WARRANTIES, INCLUDING, BUT NOT LIMITED TO, ALL IMPLIED WARRANTIES OF MERCHANTABILITY AND FITNESS FOR A PARTICULAR PURPOSE. No person or entity is authorized to bind Thomas & Betts Corporation to any other warranty, obligation or liability for any Reznor product. Installation, operation or use of the Reznor product for which this warranty is issued shall constitute acceptance of the terms hereof.

Reznor® is your global source for heating, ventilating and air conditioning equipment.

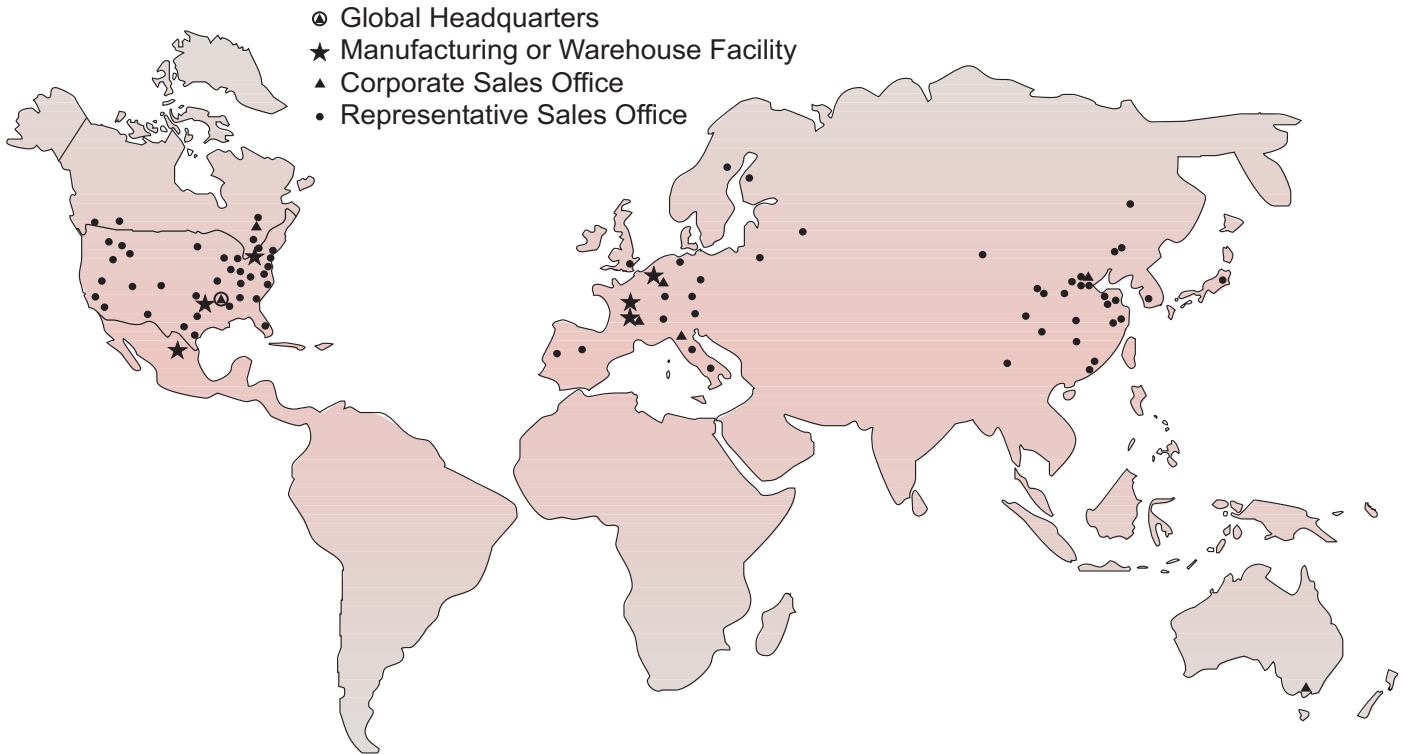

REZNOR®

For more information on Reznor HVAC Equipment,
contact your local Reznor Representative by calling
800-695-1901.

Or, find us on the internet at
www.RezSpec.com