



TRANE®

Downflow/Horizontal Right Induced Draft Gas Furnace

XB 80

TDE1A060A9361A, TDE1B060A9361A
TDE1B080A9451A, TDE1B100A9451A
TDE1C100A9601A, TDE1D120A9601A
Single-Stage Fan Assisted
Combustion System

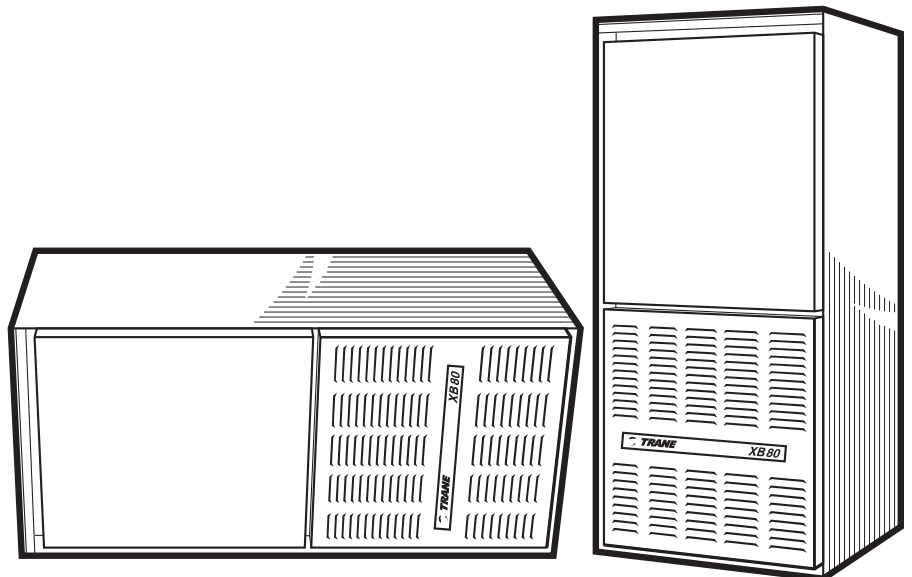

PUB. NO. 22-1677-06



General Features

NATURAL GAS MODELS

Central Heating furnace designs are certified by the American Gas Association for both natural and L.P. gas. Limit setting and rating data were established and approved under standard rating conditions using American National Standards Institute standards.

SAFE OPERATION

The Integrated System Control has solid state devices, which continuously monitor for presence of flame, when the system is in the heating mode of operation. Dual solenoid combination gas valve and regulator provide extra safety.

QUICK HEATING

Durable, cycle tested, heavy gauge **aluminized steel heat exchanger** quickly transfers heat to provide warm conditioned air to the structure.

BURNERS

Multiport Inshot burners will give years of quiet and efficient service. All models can be converted to **L.P. gas**.

INTEGRATED SYSTEM CONTROL

Exclusively designed operational program provides total control of furnace limit sensors, blowers, gas valve, flame control and includes self diagnostics for ease of service. Also contains connection points for E.A.C./humidifier.

AIR DELIVERY

The 4-speed, direct drive blower motor, has sufficient airflow for most heating and cooling requirements, will switch from heating to cooling speeds on demand from room thermostat. The blower door safety switch will prevent or terminate furnace operation when the blower door is removed.

STYLING

Heavy gauge steel and “wrap-around” cabinet construction is used in the cabinet with baked-on enamel finish for strength and beauty. The heat exchanger section of the cabinet is completely lined with foil faced fiberglass insulation. This results in quiet and efficient operation due to the excellent acoustical and insulating qualities of fiberglass. Alternate bottom, left or right side return air connection provision capability.

FEATURES AND GENERAL OPERATION

The XB 80 High Efficiency Gas Furnaces employs an Hot Surface Ignition system, which eliminates the waste of a constant burning pilot. The integrated system control lights the main burners upon a demand for heat from the room thermostat. Complete front service access.

- a. Low energy power venter
- b. Vent proving pressure switch.



Contents

Feature Summary	2
Features and Benefits	4
Standard Equipment	
Optional Equipment	
General Data	6
TDE1A060A9361A	
TDE1B060A9361A	
TDE1B080A9451A	
TDE1B100A9451A	
TDE1C100A9601A	
TDE1D120A9601A	
Performance Data	8
Electrical Data	9
Field Wiring	10
Dimensions	11



Features and Benefits

XB 80 STANDARD EQUIPMENT

- Downflow/ Horizontal
- Power supply 115/1/60
- Multi-port In-shot burners
- Silicon Nitride hot surface igniter with adaptive heat up
- Heavy gauge, wrap-around steel cabinet
- Complete front service access
- Heavy gauge aluminized steel heat exchanger
- Slide out blower assembly
- Direct drive, 4-speed motors
- Blower door safety switch
- Optional L.P. conversion kit
- Common vent capability
- Selectable cooling fan off delay option eliminates need for BAY24X045 time delay relay
- Inner blower door panel on downflow models
- 3-way vent option on downflow models (top, right, or left)

ACCESSORIES FOR XB 80

OPTIONAL EQUIPMENT (Check mark [✓] indicates accessories included).

For Comfort Controls, See price book pages	[]
CleanEffects™ Whole House Air Cleaner (14-1/2" Wide, Upflow / Side Return Furnace)	TFD145ALFR000A []
CleanEffects™ Whole House Air Cleaner (17-1/2" Wide, Upflow / Side Return Furnace)	TFD175ALFR000A []
CleanEffects™ Whole House Air Cleaner (21" Wide, Upflow / Side Return Furnace).....	TFD210ALFR000A []
CleanEffects™ Whole House Air Cleaner (24-1/2" Wide, Upflow / Side Return Furnace)	TFD245ALFR000A []
CleanEffects™ Whole House Air Cleaner (14-1/2" Wide, Downflow Furnace)	TFD14DALFR000A []
CleanEffects™ Whole House Air Cleaner (17-1/2" Wide, Downflow Furnace)	TFD17DALFR000A []
CleanEffects™ Whole House Air Cleaner (21" Wide, Downflow Furnace)	TFD21DALFR000A []
CleanEffects™ Whole House Air Cleaner (24-1/2" Wide, Downflow Furnace)	TFD24DALFR000A []
Air Filter, "Perfect Fit" High Efficiency (14-1/2" Wide Gas Furnace)	TFM145A9FR0 []
Air Filter, "Perfect Fit" High Efficiency (17-1/2" Wide Gas Furnace)	TFM175A9FR0 []
Air Filter, "Perfect Fit" High Efficiency (21" Wide Gas Furnace).....	TFM210A9FR0 []
Air Filter, "Perfect Fit" High Efficiency (24-1/2" Wide Gas Furnace)	TFM245A9FR0 []
Air Filter, "Perfect Fit" Standard Efficiency (14-1/2" Wide Gas Furnace)	TFP145A9FR0 []
Air Filter, "Perfect Fit" Standard Efficiency (17-1/2" Wide Gas Furnace)	TFP175A9FR0 []
Air Filter, "Perfect Fit" Standard Efficiency (21" Wide Gas Furnace)	TFP210A9FR0 []
Air Filter, "Perfect Fit" Standard Efficiency (24-1/2" Wide Gas Furnace)	TFP245A9FR0 []
Coil Enclosure (14-1/2" Wide Cabinets)	BAYCLE14A1422A []
Coil Enclosure (17-1/2" Wide Cabinets)	BAYCLE17A1722A []
Coil Enclosure (21" Wide Cabinets)	BAYCLE21A2130A []
Coil Enclosure (24-1/2" Wide Cabinets)	BAYCLE24A2430A []
High Altitude Switch.....	BAYHALT248 []
Downflow Subbase.....	BAYBASE205 []
Propane Conversion Kit.....	BAYLPKT210B []
Propane Conversion Kit (With Stainless Steel burners)	BAYLPSS210B []
Masonry Chimney Vent Kit	BAYVENT800B []
Filter Accessory Kit Upflow (14.5" & 17.5" Wide Cabinets)	BAYFLTR317 []
Filter Accessory Kit Upflow (21" Wide Cabinets)	BAYFLTR321 []
Filter Accessory Kit Upflow (24.5" Wide Cabinets)	BAYFLTR324 []



General Data

PRODUCT SPECIFICATIONS ^①

MODEL	TDE1A060A9361A	TDE1B060A9361A	TDE1B080A9451A
TYPE	Downflow/Horizontal	Downflow/Horizontal	Downflow/Horizontal
RATINGS ^②			
Input BTUH	60,000	60,000	80,000
Capacity BTUH (ICS) ^③	48,000	48,000	64,000
AFUE (ICS)	80.0	80.0	80.0
Temp. rise (Min.-Max.) °F	30 - 60	30 - 60	35 - 65
BLOWER DRIVE			
Diameter - Width (In.)	Direct 11 x 7	Direct 10 x 7	Direct 10 x 8
No. Used	1	1	1
Speeds (No.)	4	4	4
CFM vs. in. w.g.	See Fan Performance Table	See Fan Performance Table	See Fan Performance Table
Motor HP	1/2	1/3	1/3
R.P.M.	1075	1075	1075
Volts/Ph/Hz	115/1/60	115/1/60	115/1/60
COMBUSTION FAN - Type	Centrifugal	Centrifugal	Centrifugal
Drive - No. Speeds	Direct - 1	Direct - 1	Direct - 1
Motor HP - RPM	1/50 - 3180	1/50 - 3180	1/50 - 3180
Volts/Ph/Hz	115/1/60	115/1/60	115/1/60
FLA	1.09	1.09	1.09
FILTER — Furnished?	No	No	No
Type Recommended	High Velocity	High Velocity	High Velocity
Hi Vel. (No.-Size-Thk.)	2 - 14x20 - 1in.	2 - 14x20 - 1in.	2 - 14x20 - 1in.
VENT — Size (in.)	4 Round	4 Round	4 Round
HEAT EXCHANGER			
Type-Fired	Alum. Steel	Alum. Steel	Alum. Steel
-Unfired			
Gauge (Fired)	20	20	20
ORIFICES — Main			
Nat. Gas. Qty. — Drill Size	3 — 45	3 — 45	4 — 45
L.P. Gas Qty. — Drill Size	3 — 56	3 — 56	4 — 56
GAS VALVE	Redundant - Single Stage	Redundant - Single Stage	Redundant - Single Stage
PILOT SAFETY DEVICE			
Type	Hot Surface Ignition	Hot Surface Ignition	Hot Surface Ignition
BURNERS — Type	Multiport Inshot	Multiport Inshot	Multiport Inshot
Number	3	3	4
POWER CONN. — V/Ph/Hz ^④	115/1/60	115/1/60	115/1/60
Ampacity (In Amps)	11.2	9	9.1
Max. Overcurrent Protection (Amps)	15	15	15
PIPE CONN. SIZE (IN.)	1/2	1/2	1/2
DIMENSIONS			
Crated (In.)	H x W x D 41-3/4 x 16-1/2 x 30-1/2	H x W x D 41-3/4 x 19-1/2 x 30-1/2	H x W x D 41-3/4 x 19-1/2 x 30-1/2
WEIGHT			
Shipping (Lbs.)/Net (Lbs)	129 / 119	135 / 125	146 / 135

① Central Furnace heating designs are certified to ANSI Z21.47 and CSA 2.3.

② For U.S. applications, above input ratings (BTUH) are up to 2,000 feet, derate 4% per 1,000 feet for elevations above 2,000 feet above sea level. For Canadian applications, above input ratings (BTUH) are up to 4,500 feet, derate 4% per 1,000 feet for elevations above 4,500 feet above sea level.

③ Based on U.S. government standard tests.

④ The above wiring specifications are in accordance with National Electrical Code; however, installations must comply with local codes.



General Data

PRODUCT SPECIFICATIONS ①

MODEL	TDE1B100A9451A	TDE1C100A9601A	TDE1D120A9601A
TYPE	Downflow / Horizontal	Downflow / Horizontal	Downflow / Horizontal
RATINGS ②			
Input BTUH	100,000	100,000	120,000
Capacity BTUH (ICS) ③	80,000	81,000	96,000
AFUE (ICS)	80.0	80.0	80.0
Temp. rise (Min.-Max.) °F	35 - 65	30 - 60	30 - 60
BLOWER DRIVE	Direct	Direct	Direct
Diameter - Width (In.)	10 x 8	11 x 10	11 x 10
No. Used	1	1	1
Speeds (No.)	4	4	4
CFM vs. in. w.g.	See Fan Performance Table	See Fan Performance Table	See Fan Performance Table
Motor HP	1/3	1/2	1/2
R.P.M.	1075	1075	1075
Volts / Ph / Hz	115/1/60	115/1/60	115/1/60
COMBUSTION FAN - Type	Centrifugal	Centrifugal	Centrifugal
Drive - No. Speeds	Direct - 1	Direct - 1	Direct - 1
Motor HP - RPM	1/50 - 3180	1/50 - 3180	1/50 - 3180
Volts / Ph / Hz	115/1/60	115/1/60	115/1/60
FLA	1.09	1.09	1.09
FILTER — Furnished?	No	No	No
Type Recommended	High Velocity	High Velocity	High Velocity
Hi Vel. (No.-Size-Thk.)	2 - 14x20 - 1in	2 - 16x20 - 1in	2 - 16x20 - 1in
VENT — Size (in.)	4 Round	4 Round	4 Round
HEAT EXCHANGER			
Type - Fired	Alum. Steel	Alum. Steel	Alum. Steel
-Unfired			
Gauge (Fired)	20	20	20
ORIFICES — Main			
Nat. Gas Qty. — Drill Size	5 — 45	5 — 45	6 — 45
L.P. Gas Qty. — Drill Size	5 — 56	5 — 56	6 — 56
GAS VALVE	Redundant - Single Stage	Redundant - Single Stage	Redundant - Single Stage
PILOT SAFETY DEVICE			
Type	Hot Surface Ignition	Hot Surface Ignition	Hot Surface Ignition
BURNERS — Type	Multiport Inshot	Multiport Inshot	Multiport Inshot
Number	5	5	6
POWER CONN. — V / Ph / Hz ④	115/1/60	115/1/60	115/1/60
Ampacity (In Amps)	9.1	12.8	12.8
Max. Overcurrent Protection (Amps)	15	15	15
PIPE CONN. SIZE (IN.)	1/2	1/2	1/2
DIMENSIONS			
Crated (In.)	H x W x D 41-3/4 x 19-1/2 x 30-1/2	H x W x D 41-3/4 x 23 x 30-1/2	H x W x D 41-3/4 x 26-1/2 x 30-1/2
WEIGHT			
Shipping (Lbs.) / Net (Lbs)	156 / 145	167 / 155	189 / 176

① Central Furnace heating designs are certified to ANSI Z21.47 and CSA 2.3.

② For U.S. applications, above input ratings (BTUH) are up to 2,000 feet, derate 4% per 1,000 feet for elevations above 2,000 feet above sea level. For Canadian applications, above input ratings (BTUH) are up to 4,500 feet, derate 4% per 1,000 feet for elevations above 4,500 feet above sea level.

③ Based on U.S. government standard tests.

④ The above wiring specifications are in accordance with National Electrical Code; however, installations must comply with local codes.



Performance Data

FURNACE AIRFLOW (CFM) VS. STATIC PRESSURE (ins. w.g.)										
MODEL	SPEED TAP	0.10	0.20	0.30	0.40	0.50	0.60	0.70	0.80	0.90
TDE1A060A9361A	4 - HIGH - Black	1480	1429	1376	1318	1282	1188	1112	1029	959
	3 - MED.-HIGH - Blue	1302	1276	1229	1188	1141	1088	1024	953	882
	2 - MED.-LOW - Yellow	1115	1100	1070	1035	1000	965	918	859	790
	1 - LOW - Red	956	947	918	888	859	824	788	741	682
TDE1B060A9361A	4 - HIGH - Black	1644	1593	1525	1473	1408	1316	1269	1178	1056
	3 - MED.-HIGH - Blue	1467	1431	1383	1332	1277	1209	1137	1064	970
	2 - MED.-LOW - Yellow	1252	1216	1194	1169	1122	1079	1011	933	840
	1 - LOW - Red	1025	1022	1003	986	955	910	862	793	672
TDE1B080A9451A	4 - HIGH - Black	1798	1750	1692	1642	1575	1500	1425	1325	1225
	3 - MED.-HIGH - Blue	1384	1367	1333	1300	1275	1233	1192	1142	1083
	2 - MED.-LOW - Yellow	1210	1150	1108	1075	1042	1008	967	925	867
	1 - LOW - Red	1005	970	808	775	767	733	700	675	617
TDE1B100A9451A	4 - HIGH - Black	1767	1731	1669	1615	1546	1469	1392	1300	1146
	3 - MED.-HIGH - Blue	1382	1354	1323	1292	1254	1207	1177	1108	1038
	2 - MED.-LOW - Yellow	1130	1138	1115	1085	1054	1015	977	938	877
	1 - LOW - Red	840	831	815	792	762	731	700	654	625
TDE1C100A9601A	4 - HIGH - Black	2165	2113	2060	1995	1929	1842	1755	1674	1593
	3 - MED.-HIGH - Blue	1962	1927	1891	1839	1786	1724	1662	1581	1500
	2 - MED.-LOW - Yellow	1705	1688	1671	1636	1600	1547	1492	1435	1377
	1 - LOW - Red	1492	1467	1442	1414	1385	1346	1307	1243	1179
TDE1D120A9601A	4 - HIGH - Black	2241	2202	2163	2106	2049	1979	1908	1804	1700
	3 - MED.-HIGH - Blue	1981	1962	1942	1904	1866	1805	1743	1680	1617
	2 - MED.-LOW - Yellow	1721	1705	1688	1671	1653	1611	1569	1515	1461
	1 - LOW - Red	1476	1466	1456	1440	1423	1392	1361	1302	1243

From D341548 Rev. 1

CFM VS. TEMPERATURE RISE																				
MODEL	CFM (CUBIC FEET PER MINUTE)																			
	500	600	700	800	900	1000	1100	1200	1300	1400	1500	1600	1700	1800	1900	2000	2100	2200	2300	2400
TDE1A060A9361A				56	49	44	40	37	34	32										
TDE1B060A9361A				56	49	44	40	37	34	32										
TDE1B080A9451A					64	57	52	48	44	41										
TDE1B100A9451A								62	57	53	49	46	44	41						
TDE1C100A9601A								62	57	53	49	46	44	41	39	37	35	34	32	31
TDE1D120A9601A											59	56	52	49	47	44	42	40		

From C330671 Sh. 3 Rev. 10

Field Wiring

FIELD WIRING DIAGRAM FOR HEATING ONLY FIELD WIRING DIAGRAM FOR 1 STAGE FURNACE 1 STAGE HEATING USING A 1 STAGE HEATING THERMOSTAT NO COOLING

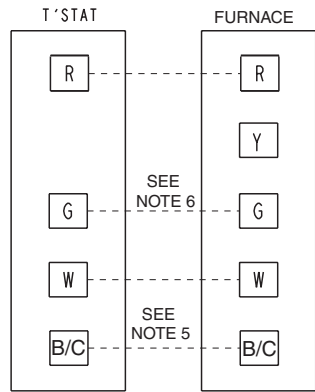

NOTES

1. BE SURE POWER SUPPLY AGREES WITH EQUIPMENT NAMEPLATE(S).
2. LOW VOLTAGE (24V.) WIRING TO BE NO. 18 AWG MIN.
3. GROUNDING OF EQUIPMENT MUST COMPLY WITH LOCAL CODES.
4. SET THERMOSTAT HEAT ANTICIPATOR PER UNIT WIRING DIAGRAM.
5. THIS CONNECTION IS ONLY USED FOR THERMOSTATS REQUIRING CONNECTION TO THE 24 V. POWER SUPPLY. (COMMON)
6. WHEN A HEATING THERMOSTAT (WITHOUT FAN SWITCH) IS USED, NO WIRING ON "G" TERMINAL OF IFC IS USED.

INTER-COMPONENT WIRING

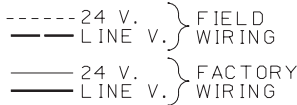

TO 115 V 1 PH.,
60 HZ., POWER
SUPPLY PER
LOCAL CODES

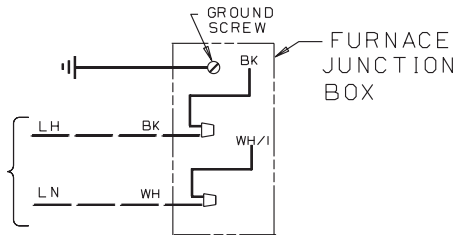

From Dwg. B342026 Rev. 0

FIELD WIRING DIAGRAM FOR HEATING/COOLING (OUTDOOR SECTION WITHOUT TRANSFORMER)

FIELD WIRING DIAGRAM FOR 1 STAGE FURNACE 1 STAGE HEATING, 1 STAGE COOLING USING A 1 STAGE HEATING, 1 STAGE COOLING THERMOSTAT (OUTDOOR SECTION WITHOUT TRANSFORMER)

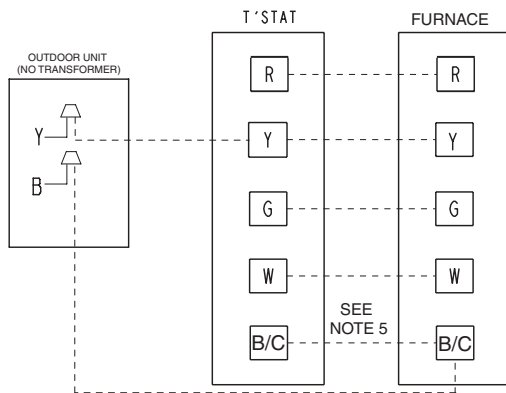

INTER-COMPONENT WIRING

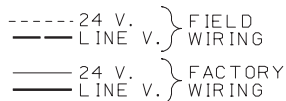

NOTES

1. BE SURE POWER SUPPLY AGREES WITH EQUIPMENT NAMEPLATE(S).
2. LOW VOLTAGE (24V.) WIRING TO BE NO. 18 AWG MIN.
3. GROUNDING OF EQUIPMENT MUST COMPLY WITH LOCAL CODES.
4. SET THERMOSTAT HEAT ANTICIPATOR PER UNIT WIRING DIAGRAM.
5. THIS CONNECTION IS ONLY USED FOR THERMOSTATS REQUIRING CONNECTION TO THE 24 V. POWER SUPPLY. (COMMON)

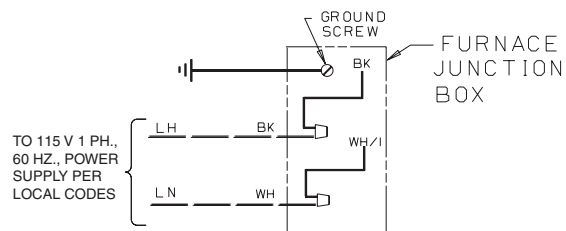

From Dwg. B342023 Rev. 0

WIRING DIAGRAM FOR TDE1 FURNACES

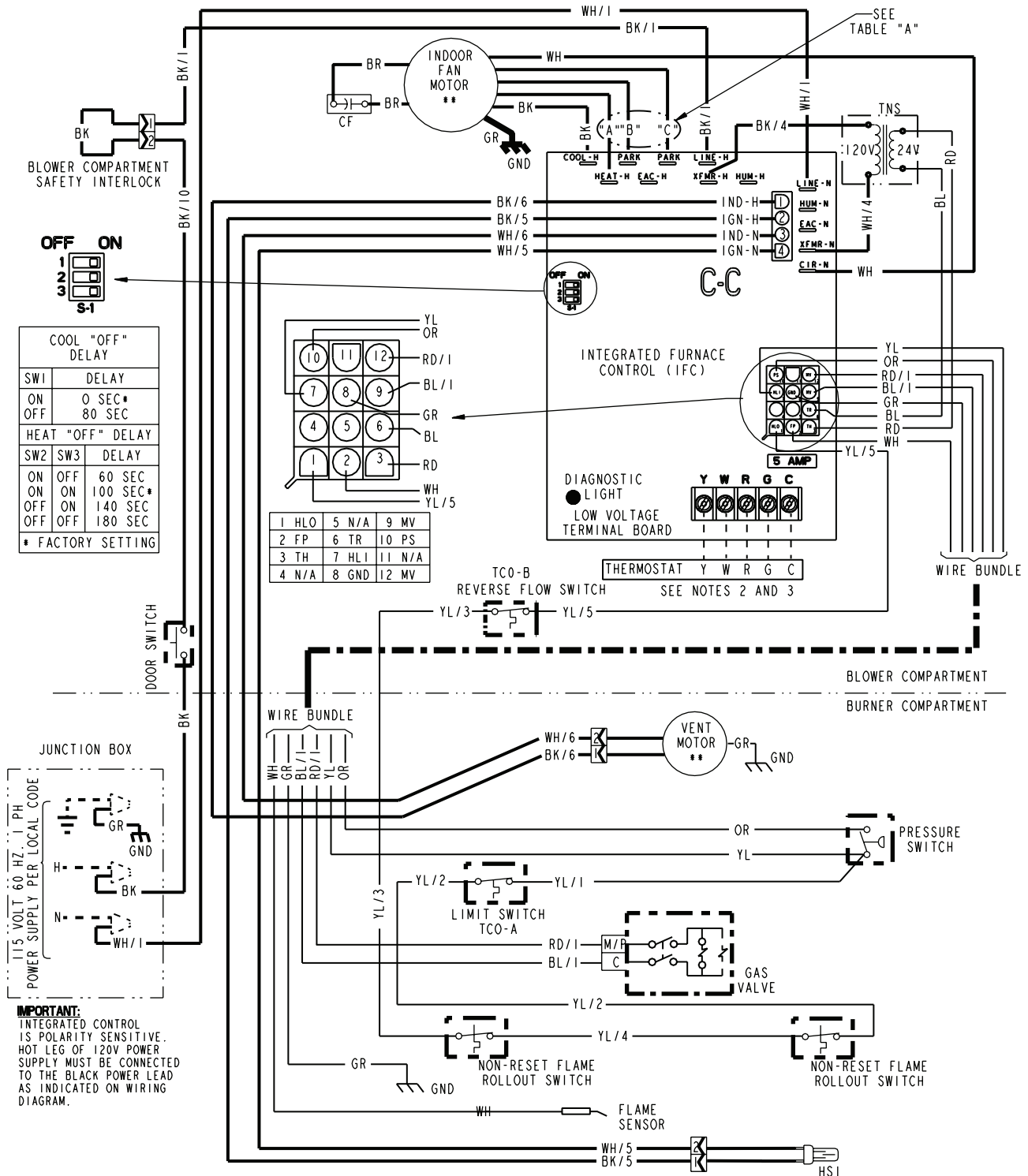

From Dwg. D342780



Electrical Data

SCHEMATIC DIAGRAM FOR TDE1 FURNACES

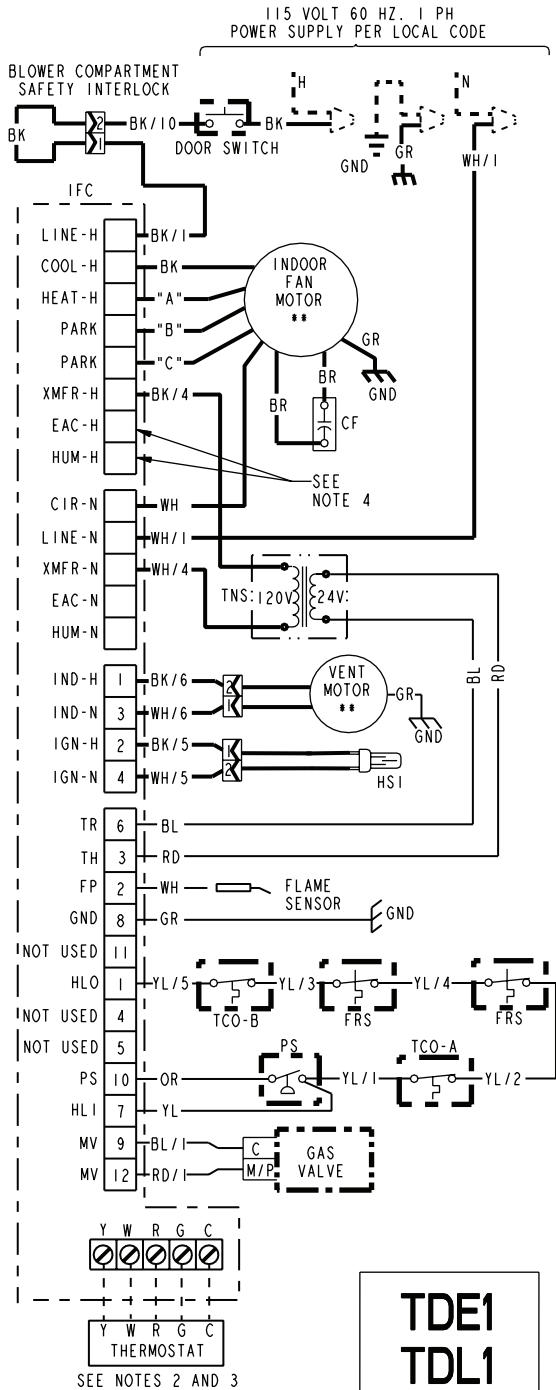

TABLE "A"			
SPEED TAPS FOR I.D. FAN MOTOR			
MODEL	HEAT "A"	PARK "B"	PARK "C"
#DE1A060A9361A* #DL1A060A9361A*	YL	RD	BL
#DE1B060A9361A* #DL1B060A9361A*	RD	BL	YL
#DE1B080A9451A* #DL1B080A9451A*	BL	RD	YL
#DE1B100A9451A* #DL1B100A9451A*	BL	RD	YL
#DE1C100A9601A*	YL	RD	BL
#DE1D120A9601A*	BL	RD	YL

RD = LOW BL = MED. HIGH
YL = MED. LOW BK = HIGH
* - MAY BE A THROUGH Z
- "T" OR "A"

WARNING

HAZARDOUS VOLTAGE:
DISCONNECT ALL ELECTRICAL POWER INCLUDING REMOTE DISCONNECTS BEFORE SERVICING.
FAILURE TO DISCONNECT POWER BEFORE SERVICING CAN CAUSE SEVERE PERSONAL INJURY OR DEATH.

CAUTION

USE COPPER CONDUCTORS ONLY!
UNIT TERMINALS ARE NOT DESIGNED TO ACCEPT OTHER TYPES OF CONDUCTORS.
FAILURE TO DO SO MAY CAUSE DAMAGE TO THE EQUIPMENT.

INTEGRATED FURNACE CONTROL
REPLACE WITH PART CNT02891 OR CNT 02183 OR EQUIVALENT
INPUT: 25 VAC, 60 HZ.
XFMR SEC. CURRENT: 450 MA.
MV OUTPUT: 1.5 A @ 24 VAC
IND OUTPUT: 2.2 FLA, 3.5 LRA @ 120 VAC
CIRC. BLOWER OUTPUT: 14.5 FLA, 26 LRA @ 120 VAC
HUMIDIFIER & AIR CLEANER
MAX. LOAD: 1.0 A @ 120 VAC
IGNITER OUTPUT: .5 A @ 120 VAC

DIAGNOSTIC CODES

- | | |
|--|---|
| FLASHING SLOW: NORMAL - NO CALL FOR HEAT | 5 FLASHES: FLAME SENSED WHEN NO FLAME SHOULD BE PRESENT |
| FLASHING FAST: NORMAL - CALL FOR HEAT | 6 FLASHES: 115 VAC POWER REVERSED |
| CONTINUOUS ON: REPLACE IFC | 7 FLASHES: POLARITY OR POOR GROUNDING |
| CONTINUOUS OFF: CHECK POWER | 8 FLASHES: GAS VALVE CIRCUIT ERROR |
| 2 FLASHES: EXTERNAL LOCKOUT (RETRIES OR RECYCLES EXCEEDED) | |
| 3 FLASHES: PRESSURE SWITCH ERROR | |
| 4 FLASHES: OPEN LIMIT DEVICE | |

TCO THERMAL CUT OUT	LINE } FACTORY 24 V WIRING	<table border="1"> <tr> <td>BK</td><td>BLACK</td><td>GR</td><td>GREEN</td> </tr> <tr> <td>WH</td><td>WHITE</td><td>BR</td><td>BROWN</td> </tr> <tr> <td>YL</td><td>YELLOW</td><td>RD</td><td>RED</td> </tr> <tr> <td>OR</td><td>ORANGE</td><td>BL</td><td>BLUE</td> </tr> </table>	BK	BLACK	GR	GREEN	WH	WHITE	BR	BROWN	YL	YELLOW	RD	RED	OR	ORANGE	BL	BLUE								
BK	BLACK		GR	GREEN																						
WH	WHITE	BR	BROWN																							
YL	YELLOW	RD	RED																							
OR	ORANGE	BL	BLUE																							
PS PRESSURE SWITCH	LINE } FIELD - 24 V WIRING																									
FRS FLAME ROLLOUT SWITCH	** INTERNAL THERMAL PROTECTION	WIRE COLOR																								
FP FLAME SENSOR	CF CAPACITOR	<table border="1"> <tr> <td>L</td><td>LINE</td><td>TH</td><td>24 VAC (HOT)</td> </tr> <tr> <td>N</td><td>NEUTRAL</td><td>TR</td><td>24 VAC (COMMON)</td> </tr> <tr> <td>GND</td><td>GROUND</td><td>MV</td><td>MAIN GAS VALVE</td> </tr> <tr> <td>B/C</td><td>COMMON</td><td>TNS</td><td>TRANSFORMER</td> </tr> <tr> <td>HLO</td><td>HIGH LIMIT OUTPUT</td><td></td><td></td> </tr> <tr> <td>HLI</td><td>HIGH LIMIT INPUT</td><td></td><td></td> </tr> </table>	L	LINE	TH	24 VAC (HOT)	N	NEUTRAL	TR	24 VAC (COMMON)	GND	GROUND	MV	MAIN GAS VALVE	B/C	COMMON	TNS	TRANSFORMER	HLO	HIGH LIMIT OUTPUT			HLI	HIGH LIMIT INPUT		
L	LINE		TH	24 VAC (HOT)																						
N	NEUTRAL	TR	24 VAC (COMMON)																							
GND	GROUND	MV	MAIN GAS VALVE																							
B/C	COMMON	TNS	TRANSFORMER																							
HLO	HIGH LIMIT OUTPUT																									
HLI	HIGH LIMIT INPUT																									
CHASSIS GROUND	COIL																									
HSI HOT SURFACE IGNITER																										
DOOR SWITCH																										

NOTES:

- IF ANY OF THE ORIGINAL WIRING AS SUPPLIED WITH THIS FURNACE MUST BE REPLACED, IT MUST BE WITH WIRE HAVING A TEMPERATURE RATING OF AT LEAST 105 C.
- THERMOSTAT HEAT ANTICIPATOR SETTING: .38 AMPS
- FOR PROPER OPERATION OF COOLING SPEED, "Y" TERMINAL MUST BE CONNECTED TO THE ROOM THERMOSTAT.
- THESE TERMINALS PROVIDE 120V POWER CONNECTIONS FOR ELECTRONIC AIR CLEANER (EAC) AND HUMIDIFIER (HUM). MAX. LOAD: 1.0 AMPS EACH.

**TDE1
TDL1
ADE1
ADL1**

Dimensions

TDE1 OUTLINE DRAWING (ALL DIMENSIONS ARE IN INCHES)

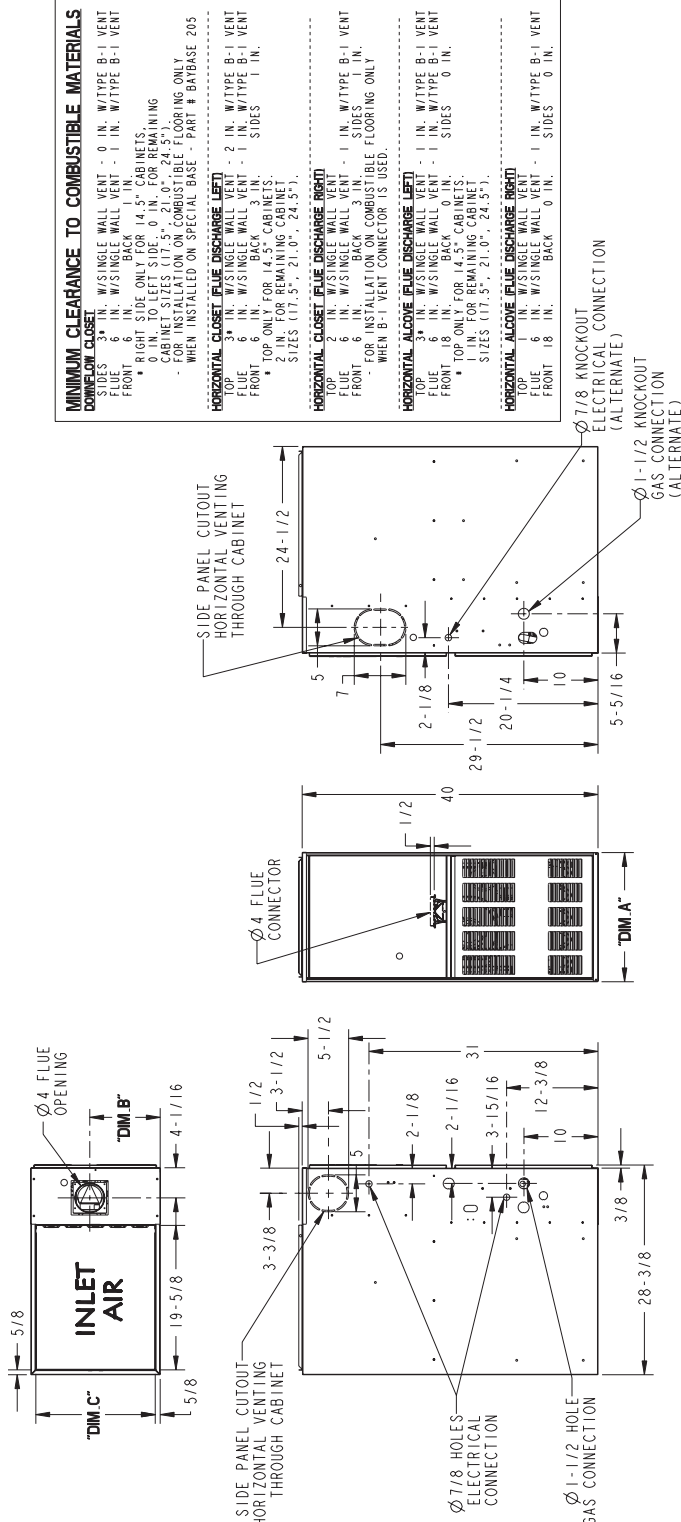

MINIMUM CLEARANCE TO COMBUSTIBLE MATERIALS

DOWNFLOW CLOSET

- SIDES 3" IN. W/SINGLE WALL VENT - 0 IN. W/TYPE B-1 VENT
- FRONT 6" IN. W/SINGLE WALL VENT - 1 IN. W/TYPE B-1 VENT
- BACK 6" IN. W/SINGLE WALL VENT - 1 IN. W/TYPE B-1 VENT
- TOP 0 IN. TO LEFT SIDE, 0 IN. FOR REMAINING
- * RIGHT SIDE ONLY FOR 14.5" CABINETS.
- * CABINET SIZES (17.5", 21.0", 24.5").
- OPEN INSTALLATION ON COMBUSTIBLE FLOORING ONLY.
- WHEN INSTALLED ON SPECIAL BASE - PART # DB/BASE 205

HORIZONTAL CLOSET FLUE DISCHARGE LEFT

- TOP 3" IN. W/SINGLE WALL VENT - 2 IN. W/TYPE B-1 VENT
- FRONT 6" IN. W/SINGLE WALL VENT - 1 IN. W/TYPE B-1 VENT
- BACK 6" IN. W/SINGLE WALL VENT - 1 IN. W/TYPE B-1 VENT
- TOP 0 IN. TO LEFT SIDE, 0 IN. FOR REMAINING
- * TOP ONLY FOR 14.5" CABINETS.
- SIZES (17.5", 21.0", 24.5").

HORIZONTAL CLOSET FLUE DISCHARGE RIGHT

- TOP 3" IN. W/SINGLE WALL VENT - 1 IN. W/TYPE B-1 VENT
- FRONT 6" IN. W/SINGLE WALL VENT - 1 IN. W/TYPE B-1 VENT
- BACK 6" IN. W/SINGLE WALL VENT - 1 IN. W/TYPE B-1 VENT
- TOP 0 IN. TO LEFT SIDE, 0 IN. FOR REMAINING
- * TOP ONLY FOR 14.5" CABINETS.
- SIZES (17.5", 21.0", 24.5").

HORIZONTAL ALCOVE FLUE DISCHARGE LEFT

- TOP 3" IN. W/SINGLE WALL VENT - 1 IN. W/TYPE B-1 VENT
- FRONT 6" IN. W/SINGLE WALL VENT - 1 IN. W/TYPE B-1 VENT
- BACK 6" IN. W/SINGLE WALL VENT - 1 IN. W/TYPE B-1 VENT
- TOP 0 IN. TO LEFT SIDE, 0 IN. FOR REMAINING
- * TOP ONLY FOR 14.5" CABINETS.
- SIZES (17.5", 21.0", 24.5").

HORIZONTAL ALCOVE FLUE DISCHARGE RIGHT

- TOP 3" IN. W/SINGLE WALL VENT - 1 IN. W/TYPE B-1 VENT
- FRONT 6" IN. W/SINGLE WALL VENT - 1 IN. W/TYPE B-1 VENT
- BACK 6" IN. W/SINGLE WALL VENT - 1 IN. W/TYPE B-1 VENT
- TOP 0 IN. TO LEFT SIDE, 0 IN. FOR REMAINING
- * TOP ONLY FOR 14.5" CABINETS.
- SIZES (17.5", 21.0", 24.5").

MODEL	DIM "A"	DIM "B"	DIM "C"	DIM "D"
TDE1A060A9361A	14-1/2"	9-5/8"	13-1/4"	13"
TDE1B060A9361A	17-1/2"	9-5/8"	16-1/4"	16"
TDE1B080A9451A	21"	13-1/16"	19-3/4"	16-1/2"
TDE1B100A9451A	24-1/2"	15-5/16"	23-1/4"	23"



Trane
6200 Troup Highway
Tyler, TX 75707
www.trane.com



Intertek

06/12

Since Trane has a policy of continuous product improvement, it reserves the right to change design and specifications without notice.