

64 TANKLESS SERIES

Continuous hot water for 1-2 bathroom homes*

RTG-64DV indoor direct vent and RTG-64X outdoor natural and LP models – 11,000 - 150,000 BTU max.
6.4 gal./min at 35° F rise max., 5.6 gal./min. at 45° F rise

Limited Warranty:

12-Year on heat exchanger, 5-Year on parts, 1-Year on labor

See Residential Warranty Information Brochure for complete warranty information.

- 3"/5" Concentric Vent System with Integrated Condensate Collector
- Connects to Metal Fab Inc., 3"/5" Concentric Venting without an adapter
- Next Generation Burner Technology
- **Industry First!** .26 GPM Minimum Flow Rate, .40 GPM Minimum Activation Flow Rate
- UMC-117 remote control and 10 ft. of thermostat wire is included
- EZ-Link™ cable available for high demand applications to connect two tankless units to operate as one
- Manifold up to 6 units with an optional MIC-6 manifold control board
- Link up to 20 Rheem units for manifold installations by using the optional MIC-185 and MICS-180 manifold control assembly
- High-altitude capability – up to 9,840 ft. elevation above sea level (no chip required)
- **Exclusive!** Guardian OFW™ overheat film wrap
- All Rheem tankless models are third-party efficiency certified by GAMA
- Continuous hot water, energy saving and compact, space saving design
- Intelligent electronic controls designed to increase energy efficiency and safety
- Self Diagnostic System
- Digital display shows temperature setting and maintenance codes
- Built-in electric blower
- Supplied with a 120 volt power cord
- Environmentally friendly Low NOx burner meets SCAQMD rule 1146 requirements
- Freeze protection to -30° F

Product appearance may differ.

* Based on simultaneous showers using 2.5 gallons per minute. Flow rates vary depending on temperature of cold water supply.



Tankless water heaters
Continuous hot water



relax
It's Rheem®

See reverse for specifications.

64 TANKLESS SERIES

Specifications

DESCRIPTION			FEATURES				ROUGHING IN DIMENSIONS (SHOWN IN INCHES)							ENERGY INFO.	
MODEL NUMBER	GAS INPUT BTU/HR.	TYPE	TEMP. RANGE	WATER FLOW RATE			CONNECTION		HEIGHT	WIDTH	DEPTH	VENT DIAMETER (INCHES)	SHIP WEIGHT (LBS.)	ENERGY FACTOR	D.O.E. ANN. OP. COST NAT/LP
				GPM @ 77° RISE MAX.	GPM @ 45° RISE MAX.	GPM @ 35° RISE MAX.	WATER	GAS							

RHEEM TANKLESS WATER HEATERS FOR 3 BATHROOM HOMES

RTG-64DVN	11,000 - 150,000	Indoor Direct Vent	85° to 140° F	3.3	5.6	6.4	3/4	3/4	25-5/8	13-7/8	9-7/8	3 by 5 CONCENTRIC	54	.82	\$223/\$374
RTG-64XN	11,000 - 150,000	Outdoor	85° to 140° F	3.3	5.6	6.4	3/4	3/4	23-5/8	13-7/8	8-7/8	N/A	54	.82	\$223/\$374

Indoor Direct Vent

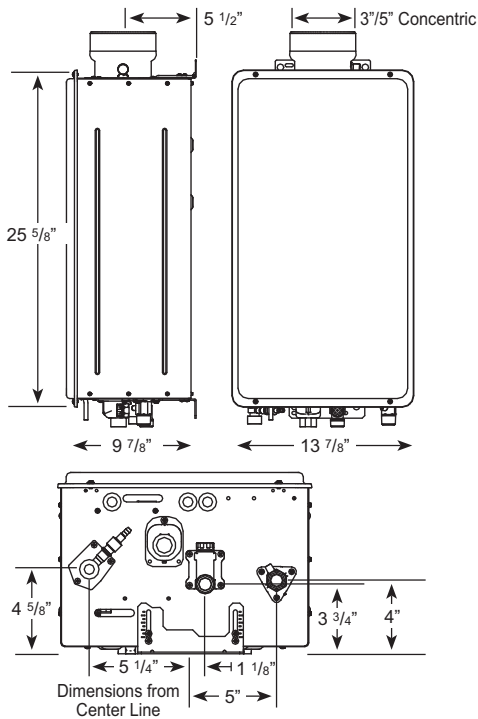

Outdoor

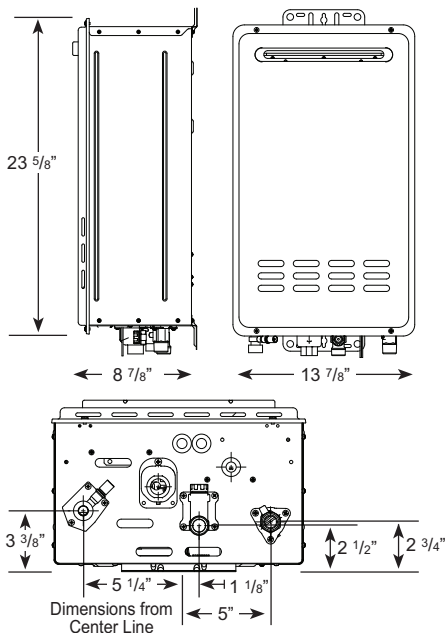

Energy Factor and Average Annual Operating Costs based on D.O.E. (Department of Energy) test procedures. D.O.E. national average fuel rate natural gas \$1.218/therm; LP \$1.87/gallon.

All models are available in Natural Gas and Propane (LP). For Propane replace the N with P when ordering.

- Factory set maximum temperature is 120° F. See Use and Care Manual for setting.
- Consult factory for information on sizing the application.

Vent Termination Kits are required for Direct Vent models. Contact your distributor for details.

Proper gas pressure must be ensured to supply tankless gas water heaters – up to 150,000 BTU for RTG-64 models. (Consult your gas supplier)

Model Number	Temperature Rise (° F)								
	35°	45°	50°	60°	70°	77°	80°	90°	100°
RTG-64 Water Flow (GPM)	6.4	5.6	5.1	4.2	3.6	3.3	3.2	2.8	2.5

Above estimates are for sizing purposes only.

Water Heater Flow Rate Curves

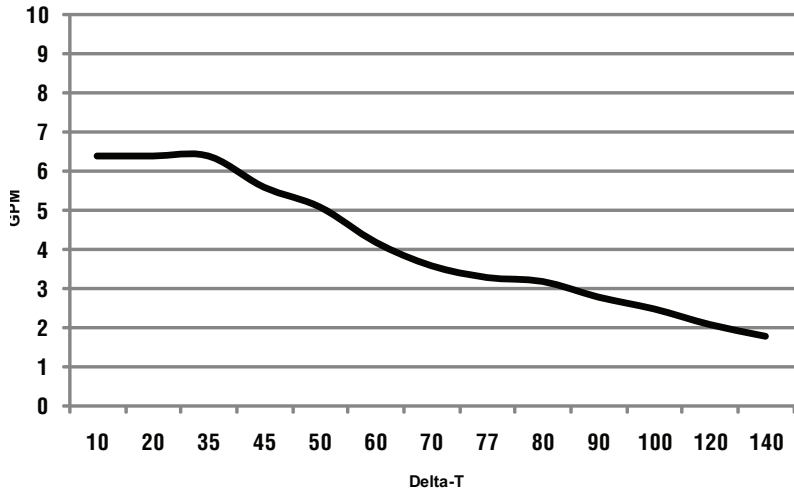

These units are designed to meet or exceed ANSI (American National Standards Institute) requirements and have been tested according to D.O.E. test procedures and meet or exceed the energy efficiency requirements of NAECA, ASHRAE standard 90, ICC Code and all state energy efficiency performance criteria for energy consuming appliances.

Before purchasing this appliance, read important energy cost and efficiency information available from your supplier.

In keeping with its policy of continuous progress and product improvement, Rheem reserves the right to make changes without notice.

Rheem Water Heating and Heating & Cooling Products
101 Bell Road • Montgomery, AL 36117-4305
1-866-720-2076 • www.rheem.com

Rheem Canada Ltd./Ltée • Water Heater Division
125 Edgeware Road, Unit 1, Brampton, Ontario L6Y 0P5

Printed in U.S.A. 06/11 WP Form No. 101-50-64 Rev. 3