

American Standard

HEATING & AIR
CONDITIONING

UPFLOW/HORIZONTAL
TWO-STAGE, VARIABLE SPEED
GAS-FIRED FURNACE

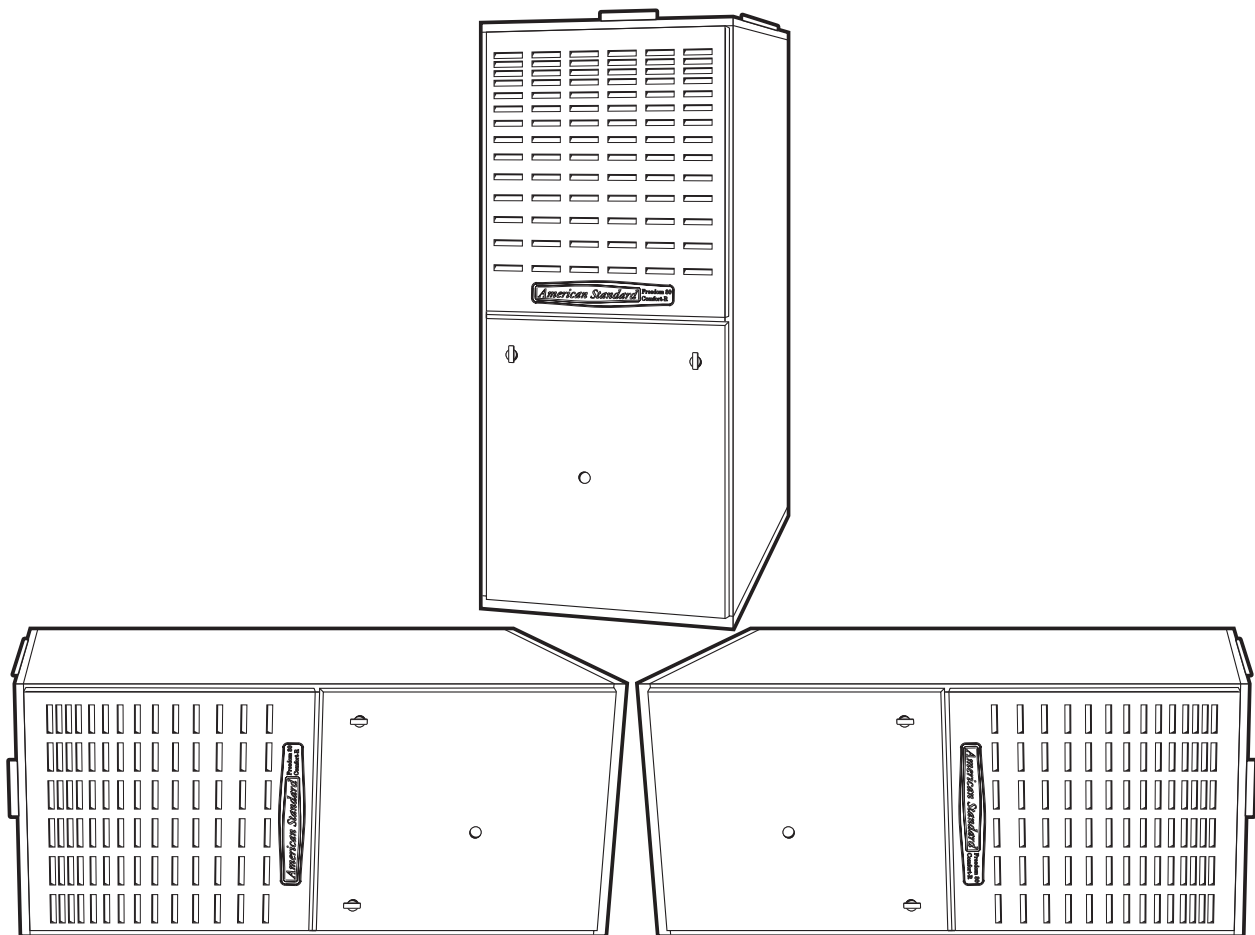

FREEDOM 80vs

MODELS

AUD2B060A9V3VB

AUD2B080A9V3VB

AUD2C080A9V4VB

AUD2C080B9V4VA

AUD2B100A9V3VB

AUD2C100A9V5VB

AUD2C100B9V5VA

AUD2D120A9V5VB

AUD2D120B9V5VA

AUD2D140A9V5VB

PRODUCT DATA

American Standard Heating & Air Conditioning

FREEDOM 80vs STANDARD EQUIPMENT

- Upflow/Horizontal and
- Power supply 115/1/60
- 2-stage gas valve
- 2-speed venter
- Variable speed blower motor
- Silicon Nitride hot surface igniter with adaptive heat up
- Integrated solid state control
- Attractive color accents
- Heavy gauge aluminized steel heat exchanger
- Multi-port In-shot burners
- Complete front service access
- Alternate bottom/left/right return air
- Slide out blower assembly
- Hinged blower door
- Perfect fit door catches
- Insulated blower door
- Gasketed blower door
- Internal filter rack
- Standard filter sizes
- Two-tone color
- Direct drive, variable speed motor
- Integrated solid state control with self-diagnostics
- Common vent capability
- Cleanable framed filters
- Optional L. P. conversion kit
- Left/right gas connection
- Accessory hook-up capability
- Selectable cooling fan off delay eliminates need for BAY24X045 time delay kit
- Enhanced cooling control

FREEDOM 80vs OPTIONAL EQUIPMENT

Thermostat, Mechanical 2-Stage Heating/1-Stage Cooling	TAYSTAT241 []
Thermostat, Mechanical Heating Only With Fan Switch.....	BAYSTAT303 []
Thermostat, Mechanical Heating Only	BAYSTAT388 []
Thermostat, Heating/Cooling Single Stage (Mounts Horizontally)	AY28X092 []
Thermostat, Electronic Non-programmable 1-Stage Heating/1-Stage Cooling.....	BAYSTAT370 []
Thermostat, Electronic Programmable (5-2) 1-Stage Heating/1-Stage Cooling.....	BAYSTAT340 []
Thermostat, Heating/Cooling Single Stage (Mounts Vertically).....	BAYSTAT305 []
Thermostat, Electronic Programmable 2-Stage Heating/2-Stage Cooling	TAYSTAT302C []
Thermostat, Electronic Programmable 1-Stage Heating/1-Stage Cooling	TAYSTAT300C []
Propane Conversion Kit.....	BAYLPKT210A []
Electronic Air Filter, "Perfect Fit" High Efficiency (17-1/2" Wide Gas Furnace).....	TFM175A9FR0 []
Electronic Air Filter, "Perfect Fit" High Efficiency (21" Wide Gas Furnace).....	TFM210A9FR0 []
Electronic Air Filter, "Perfect Fit" High Efficiency (24-1/2" Wide Gas Furnace).....	TFM245A9FR0 []
Electronic Air Filter, "Perfect Fit" Standard Efficiency (17-1/2" Wide Gas Furnace).....	TFP175A9FR0 []
Electronic Air Filter, "Perfect Fit" Standard Efficiency (21" Wide Gas Furnace).....	TFP210A9FR0 []
Electronic Air Filter, "Perfect Fit" Standard Efficiency (24-1/2" Wide Gas Furnace).....	TFP245A9FR0 []
Coil Enclosure (17-1/2" Wide Cabinets)	BAYCLE17A1722A []
Coil Enclosure (21" Wide Cabinets)	BAYCLE21A2130A []
Coil Enclosure (24-1/2" Wide Cabinets)	BAYCLE24A2430A []
Side Filter Rack	BAYFLTR200 []
High Altitude Switch.....	BAYHALT249 []
Masonry Chimney Vent Kit (Upflow models only).....	BAYVENT800B []
Filter Rack Kit ①	BAYRACK960A []

① Available for models with 1800 CFM or greater which require an additional side return.

FEATURES

NATURAL GAS MODELS — Central Heating furnace designs are certified by the American Gas Association for both natural and L.P. gas. Limit setting and rating data were established and approved under standard rating conditions using American National Standards Institute standards.

SAFE OPERATION — The Integrated System Control has solid state devices, which continuously monitor for presence of flame, when the system is in the heating mode of operation. Dual solenoid combination gas valve and regulator provide extra safety.

QUICK HEATING — Durable, cycle tested, heavy gauge **aluminized steel heat exchanger** quickly transfers heat to provide warm conditioned air to the structure. **Low energy power vent blower**, to increase efficiency and provide a positive discharge of gas fumes to the outside.

BURNERS — Multi-port In-shot burners will give years of quiet and efficient service. All models can be converted to **L.P. gas**.

INTEGRATED SYSTEM CONTROL — Exclusively designed operational program provides total control of furnace limit sensors, blowers, gas valve, flame control and includes self-diagnostics for ease of service. Also contains connection points for E.A.C./humidifier.

AIR DELIVERY — The variable speed, direct drive blower motor, has sufficient airflow for most heating and cooling requirements, will switch from heating to cooling speeds on demand from room thermostat. The blower door safety switch will prevent or terminate furnace operation when the blower door is removed.

STYLING — **Heavy gauge steel and "wrap-around" cabinet construction** is used in the cabinet with baked-on enamel finish for strength and beauty. The heat exchanger section of the cabinet is completely lined with foil faced fiberglass insulation. This results in quiet and efficient operation due to the excellent acoustical and insulating qualities of fiberglass. Built-in bottom pan and alternate bottom, left or right side return air connection provision.

FEATURES AND GENERAL OPERATION — The Freedom 80vs High Efficiency Gas Furnaces employ a Hot Surface Ignition system, which eliminates the waste of a constant burning pilot. The integrated system control lights the main burners upon a demand for heat from the room thermostat. Complete front service access.

- a. Low energy power venter
- b. Vent proving pressure switch.

AUD-R9V PRODUCT SPECIFICATIONS^①

MODEL	AUD2B060A9V3VB	AUD2B080A9V3VB	AUD2C080A9V4VB
TYPE	Upflow / Horizontal	Upflow / Horizontal	Upflow / Horizontal
RATINGS ^②			
1st Stage Input BTUH	39,000	52,000	52,000
1st Stage Capacity BTUH (ICS) ^③	31,200	41,600	41,600
2nd Stage Input BTUH	60,000	80,000	80,000
2nd Stage Capacity BTUH (ICS) ^③	48,000	64,000	64,000
Temp. rise (Min.-Max.) °F.	30 - 60	30 - 60	30 - 60
BLOWER DRIVE			
	Direct	Direct	Direct
Diameter - Width (In.)	10 x 7	10 x 7	10 x 10
No. Used	1	1	1
Speeds (No.)	Variable	Variable	Variable
CFM vs. in. w.g.	See Airflow Table	See Airflow Table	See Airflow Table
Motor HP	1/2	1/2	3/4
R.P.M.	Variable	Variable	Variable
Volts / Ph / Hz	115/1/60	115/1/60	115/1/60
COMBUSTION FAN - Type			
	Centrifugal	Centrifugal	Centrifugal
Drive - No. Speeds	Direct - 2	Direct - 2	Direct - 2
Motor HP - RPM	1/50 - 3000	1/50 - 3000	1/50 - 3000
Volts / Ph / Hz	115/1/60	115/1/60	115/1/60
FLA	0.7	0.7	0.7
FILTER — Furnished?			
	Yes	Yes	Yes
Type Recommended	High Velocity	High Velocity	High Velocity
Hi Vel. (No.-Size-Thk.)	1 - 17x25 - 1in.	1 - 17x25 - 1in.	1 - 20x25 - 1in.
VENT — Size (In.)			
	4 Round	4 Round	4 Round
HEAT EXCHANGER			
Type -Fired	Alum. Steel - Type 1	Alum. Steel - Type 1	Alum. Steel - Type 1
-Unfired			
Gauge (Fired)	20	20	20
ORIFICES — Main			
Nat. Gas Qty. — Drill Size	3 — 45	4 — 45	4 — 45
L. P. Gas Qty. — Drill Size	3 — 56	4 — 56	4 — 56
GAS VALVE			
	Redundant - Two Stage	Redundant - Two Stage	Redundant - Two Stage
PILOT SAFETY DEVICE			
Type	Hot Surface Ignition	Hot Surface Ignition	Hot Surface Ignition
BURNERS — Type			
	Multi-port In-shot	Multi-port In-shot	Multi-port In-shot
Number	3	4	4
POWER CONN. — V/Ph/Hz ^④			
	115/1/60	115/1/60	115/1/60
Ampacity (In Amps)	10.5	10.5	12.9
Max. Overcurrent Protection (Amps)	15	15	20
PIPE CONN. SIZE (In.)			
	1/2	1/2	1/2
DIMENSIONS			
	H x W x D	H x W x D	H x W x D
Crated (In.)	41-3/4 x 19-1/2 x 30-1/2	41-3/4 x 19-1/2 x 30-1/2	41-3/4 x 23 x 30-1/2
WEIGHT			
Shipping (Lbs.)/Net (Lbs.)	136 / 126	142 / 132	166 / 155

① Central Furnace heating designs are certified to ANSI Z21.47 / CSA 2.3

② For U.S. applications, above input ratings (BTUH) are up to 2,000 feet, derate 4% per 1,000 feet for elevations above 2,000 feet above sea level. For Canadian applications, above input ratings (BTUH) are up to 4,500 feet, derate 4% per 1,000 feet for elevations above 4,500 feet above sea level.

③ Based on U.S. government standard tests.

④ The above wiring specifications are in accordance with National Electrical Code; however, installations must comply with local codes.

PRODUCT DATA

American Standard Heating & Air Conditioning

AUD-R9V PRODUCT SPECIFICATIONS^①

MODEL	AUD2C080B9V4VA ^⑤	AUD2B100A9V3VB	AUD2C100A9V5VB
TYPE	Upflow/Horizontal	Upflow/Horizontal	Upflow/Horizontal
RATINGS ^②			
1st Stage Input BTUH	52,000	65,000	65,000
1st Stage Capacity BTUH (ICS) ^③	41,600	52,000	52,000
2nd Stage Input BTUH	80,000	100,000	100,000
2nd Stage Capacity BTUH (ICS) ^③	64,000	80,000	79,000
Temp. rise (Min.-Max.) °F.	30 - 60	40 - 70	35 - 65
BLOWER DRIVE			
Drive	Direct	Direct	Direct
Diameter - Width (In.)	10 x 10	10 x 7	10 x 10
No. Used	1	1	1
Speeds (No.)	Variable	Variable	Variable
CFM vs. in. w.g.	See Airflow Table	See Airflow Table	See Airflow Table
Motor HP	3/4	1/2	1
R.P.M.	Variable	Variable	Variable
Volts/Ph/Hz	115/1/60	115/1/60	115/1/60
COMBUSTION FAN - Type			
Drive - No. Speeds	Centrifugal Direct - 2	Centrifugal Direct - 2	Centrifugal Direct - 2
Motor HP - RPM	1/50 - 3000	1/50 - 3000	1/50 - 3000
Volts/Ph/Hz	115/1/60	115/1/60	115/1/60
FLA	0.7	0.87	0.87
FILTER — Furnished?			
Type Recommended	Yes High Velocity	Yes High Velocity	Yes High Velocity
Hi Vel. (No.-Size-Thk.)	1 - 20x25 - 1in.	1 - 17x25 - 1in.	1 - 20x25 - 1in.
VENT — Size (In.)			
	4 Round	4 Round	4 Round
HEAT EXCHANGER			
Type -Fired	Alum. Steel - Type 1	Alum. Steel - Type 1	Alum. Steel - Type 1
-Unfired			
Gauge (Fired)	20	20	20
ORIFICES — Main			
Nat. Gas Qty. — Drill Size	4 — 45	5 — 45	5 — 45
L. P. Gas Qty. — Drill Size	4 — 56	5 — 56	5 — 56
GAS VALVE			
	Redundant - Two Stage	Redundant - Two Stage	Redundant - Two Stage
PILOT SAFETY DEVICE			
Type	Hot Surface Ignition	Hot Surface Ignition	Hot Surface Ignition
BURNERS — Type			
Number	Multi-port In-shot 4	Multi-port In-shot 5	Multi-port In-shot 5
POWER CONN. — V/Ph/Hz ^④			
Ampacity (In Amps)	115/1/60 12.9	115/1/60 10.8	115/1/60 14.9
Max. Overcurrent Protection (Amps)	20	15	20
PIPE CONN. SIZE (In.)			
	1/2	1/2	1/2
DIMENSIONS			
Crated (In.)	H x W x D 41-3/4 x 23 x 30-1/2	H x W x D 41-3/4 x 19-1/2 x 30-1/2	H x W x D 41-3/4 x 23 x 30-1/2
WEIGHT			
Shipping (Lbs.)/Net (Lbs.)	166 / 155	142 / 132	166 / 155

① Central Furnace heating designs are certified to ANSI Z21.47 / CSA 2.3

② For U.S. applications, above input ratings (BTUH) are up to 2,000 feet, derate 4% per 1,000 feet for elevations above 2,000 feet above sea level. For Canadian applications, above input ratings (BTUH) are up to 4,500 feet, derate 4% per 1,000 feet for elevations above 4,500 feet above sea level.

③ Based on U.S. government standard tests.

④ The above wiring specifications are in accordance with National Electrical Code; however, installations must comply with local codes.

⑤ Model uses high efficiency blower.

AUD-R9V PRODUCT SPECIFICATIONS^①

MODEL	AUD2C100B9V5VA ^⑤	AUD2D120A9V5VB	AUD2D120B9V5VA ^⑤	AUD2D140A9V5VB
TYPE	Upflow / Horizontal	Upflow / Horizontal	Upflow / Horizontal	Upflow / Horizontal
RATINGS^②				
1st Stage Input BTUH	65,000	78,000	78,000	91,000
1st Stage Capacity BTUH (ICS) ^③	52,000	62,400	62,400	72,800
2nd Stage Input BTUH	100,000	120,000	120,000	140,000
2nd Stage Capacity BTUH (ICS) ^③	79,000	97,000	97,000	111,000
Temp. rise (Min.-Max.) °F.	35 - 65	35 - 65	35 - 65	40 - 70
BLOWER DRIVE				
Drive	Direct	Direct	Direct	Direct
Diameter - Width (In.)	10 x 10	10 x 10	10 x 10	10 x 10
No. Used	1	1	1	1
Speeds (No.)	Variable	Variable	Variable	Variable
CFM vs. in. w.g.	See Airflow Table	See Airflow Table	See Airflow Table	See Airflow Table
Motor HP	1	1	1	1
R.P.M.	Variable	Variable	Variable	Variable
Volts / Ph / Hz	115/1/60	115/1/60	115/1/60	115/1/60
COMBUSTION FAN - Type				
Drive - No. Speeds	Centrifugal	Centrifugal	Centrifugal	Centrifugal
Motor HP - RPM	Direct - 2	Direct - 2	Direct - 2	Direct - 2
Volts / Ph / Hz	1/50 - 3000	1/50 - 3000	1/50 - 3000	1/50 - 3000
FLA	115/1/60	115/1/60	115/1/60	115/1/60
	0.87	1.14	1.14	1.16
FILTER — Furnished?				
Type Recommended	Yes	Yes	Yes	Yes
Hi Vel. (No.-Size-Thk.)	High Velocity	High Velocity	High Velocity	High Velocity
	1 - 20x25 - 1in.	1 - 24x25 - 1in.	1 - 24x25 - 1in.	1 - 24x25 - 1in.
VENT — Size (In.)				
	4 Round	4 Round	4 Round	4 Round
HEAT EXCHANGER				
Type -Fired	Alum. Steel - Type 1	Alum. Steel - Type 1	Alum. Steel - Type 1	Alum. Steel - Type 1
-Unfired				
Gauge (Fired)	20	20	20	20
ORIFICES — Main				
Nat. Gas Qty. — Drill Size	5 — 45	6 — 45	6 — 45	7 — 45
L. P. Gas Qty. — Drill Size	5 — 56	6 — 56	6 — 56	7 — 56
GAS VALVE				
	Redundant - Two Stage	Redundant - Two Stage	Redundant - Two Stage	Redundant - Two Stage
PILOT SAFETY DEVICE				
Type	Hot Surface Ignition	Hot Surface Ignition	Hot Surface Ignition	Hot Surface Ignition
BURNERS — Type				
Number	Multi-port In-shot	Multi-port In-shot	Multi-port In-shot	Multi-port In-shot
	5	6	6	7
POWER CONN. — V/Ph/Hz^④				
Ampacity (In Amps)	115/1/60	115/1/60	115/1/60	115/1/60
Max. Overcurrent Protection (Amps)	14.9	15.3	15.3	15.3
	20	20	20	20
PIPE CONN. SIZE (In.)				
	1/2	1/2	1/2	1/2
DIMENSIONS				
Crated (In.)	H x W x D	H x W x D	H x W x D	H x W x D
	41-3/4 x 23 x 30-1/2	41-3/4 x 26-1/2 x 30-1/2	41-3/4 x 26-1/2 x 30-1/2	41-3/4 x 26-1/2 x 30-1/2
WEIGHT				
Shipping (Lbs.)/Net (Lbs.)	166 / 155	193 / 181	193 / 181	197 / 185

① Central Furnace heating designs are certified to ANSI Z21.47 / CSA 2.3

② For U.S. applications, above input ratings (BTUH) are up to 2,000 feet, derate 4% per 1,000 feet for elevations above 2,000 feet above sea level. For Canadian applications, above input ratings (BTUH) are up to 4,500 feet, derate 4% per 1,000 feet for elevations above 4,500 feet above sea level.

③ Based on U.S. government standard tests.

④ The above wiring specifications are in accordance with National Electrical Code; however, installations must comply with local codes.

⑤ Model uses high efficiency blower.

PRODUCT DATA

American Standard Heating & Air Conditioning

*UD2B060A9V3VB FURNACE HEATING AIRFLOW (CFM) AND POWER (WATTS) VS. EXTERNAL STATIC PRESSURE WITH FILTER									
	AIRFLOW SETTING	DIP SWITCH SETTING			EXTERNAL STATIC PRESSURE				
		SW7	SW8		0.1	0.3	0.5	0.7	0.9
HEATING 1ST STAGE	LOW	ON	ON	CFM TEMP. RISE WATTS	589 49 65	604 48 95	619 47 125	604 48 160	607 48 200
	MEDIUM **	ON	OFF	CFM TEMP. RISE WATTS	663 44 75	694 42 120	684 42 145	681 42 185	686 42 220
	HIGH	OFF	OFF	CFM TEMP. RISE WATTS	775 37 105	781 37 145	776 37 180	805 36 230	811 36 270
HEATING 2ND STAGE	LOW	ON	ON	CFM TEMP. RISE WATTS	813 55 110	818 54 150	818 54 185	837 53 240	842 53 280
	MEDIUM **	ON	OFF	CFM TEMP. RISE WATTS	907 49 140	919 48 200	942 47 240	958 46 300	959 46 330
	HIGH	OFF	OFF	CFM TEMP. RISE WATTS	1038 43 190	1066 42 260	1086 41 325	1089 41 365	1079 41 415

*UD2B060A9V3VB FURNACE COOLING AIRFLOW (CFM) AND POWER (WATTS) VS. EXTERNAL STATIC PRESSURE WITH FILTER											
OUTDOOR UNIT SIZE (TONS)	AIRFLOW SETTING	DIP SWITCH SETTING					EXTERNAL STATIC PRESSURE				
		SW1	SW2	SW3	SW4		0.1	0.3	0.5	0.7	0.9
1.5	LOW (350 CFM/ TON)	ON	ON	OFF	ON	CFM WATTS	499 50	537 80	520 110	520 145	500 175
	NORMAL (400 CFM/ TON)	ON	ON	OFF	OFF	CFM WATTS	605 60	610 80	610 120	597 155	593 180
	HIGH (450 CFM/ TON)	ON	ON	ON	OFF	CFM WATTS	649 75	681 110	665 145	665 180	672 220
2	LOW (350 CFM/ TON)	OFF	ON	OFF	ON	CFM WATTS	680 80	722 125	680 150	696 190	696 225
	NORMAL (400 CFM/ TON)	OFF	ON	OFF	OFF	CFM WATTS	798 105	804 145	809 170	823 235	818 280
	HIGH (450 CFM/ TON)	OFF	ON	ON	OFF	CFM WATTS	884 145	896 180	924 240	931 280	931 330
2.5	LOW (350 CFM/ TON)	ON	OFF	OFF	ON	CFM WATTS	858 125	863 175	882 220	894 275	895 320
	NORMAL (400 CFM/ TON)	ON	OFF	OFF	OFF	CFM WATTS	984 170	1017 225	1038 295	1017 330	1017 375
	HIGH (450 CFM/ TON)	ON	OFF	ON	OFF	CFM WATTS	1125 245	1138 315	1150 370	1161 435	1161 475
3 **	LOW (350 CFM/ TON)	OFF	OFF	OFF	ON	CFM WATTS	1035 205	1056 265	1076 330	1076 370	1076 430
	NORMAL ** (400 CFM/ TON)	OFF	OFF	OFF	OFF	CFM WATTS	1208 300	1247 360	1268 440	1278 485	1200 490
	HIGH (450 CFM/ TON)	OFF	OFF	ON	OFF	CFM WATTS	1380 440	1410 500	1402 550	1350 550	1235 525

NOTES:

- *FIRST LETTER MAY BE "A" OR "T"
- **FACTORY SETTING.
- CONTINUOUS FAN SETTING: HEATING OR COOLING AIRFLOW IS APPROXIMATELY 50% OF SELECTED COOLING VALUE.
- LOW 350 CFM/TON IS RECOMMENDED FOR VARIABLE SPEED APPLICATION FOR COMFORT & HUMID CLIMATE SETTING: NORMAL IS 400 CFM/TON: HIGH 450 CFM/TON IS FOR DRY CLIMATE SETTING.

*UD2B080A9V3VB FURNACE HEATING AIRFLOW (CFM) AND POWER (WATTS) VS. EXTERNAL STATIC PRESSURE WITH FILTER									
	AIRFLOW SETTING	DIP SWITCH SETTING			EXTERNAL STATIC PRESSURE				
		SW 7	SW 8		0.1	0.3	0.5	0.7	0.9
HEATING 1ST STAGE	LOW	ON	ON	CFM TEMP. RISE WATTS	800 48 100	790 49 135	765 50 155	750 52 200	730 53 230
	MEDIUM **	ON	OFF	CFM TEMP. RISE WATTS	910 43 130	890 44 170	875 44 210	860 45 240	820 47 280
	HIGH	OFF	OFF	CFM TEMP. RISE WATTS	1060 37 188	1020 38 220	1010 39 265	1010 39 310	1000 39 350
HEATING 2ND STAGE	LOW	ON	ON	CFM TEMP. RISE WATTS	1110 54 210	1090 55 260	1090 55 310	1080 55 350	1065 56 400
	MEDIUM **	ON	OFF	CFM TEMP. RISE WATTS	1245 48 300	1240 48 355	1240 48 410	1230 48 460	1215 49 500
	HIGH	OFF	OFF	CFM TEMP. RISE WATTS	1415 42 410	1400 42 470	1400 42 530	1375 43 580	1320 45 590

*UD2B080A9V3VB FURNACE COOLING AIRFLOW (CFM) AND POWER (WATTS) VS. EXTERNAL STATIC PRESSURE WITH FILTER											
OUTDOOR UNIT SIZE (TONS)	AIRFLOW SETTING	DIP SWITCH SETTING					EXTERNAL STATIC PRESSURE				
		SW 1	SW 2	SW 3	SW 4		0.1	0.3	0.5	0.7	0.9
2.5	LOW (350 CFM/TON)	OFF	ON	OFF	ON	CFM WATTS	880 120	875 155	860 190	845 225	840 245
	NORMAL (400 CFM/TON)	OFF	ON	OFF	OFF	CFM WATTS	1020 170	1000 205	990 240	980 280	960 320
	HIGH (450 CFM/TON)	OFF	ON	ON	OFF	CFM WATTS	1110 210	110 260	1110 320	1100 350	1100 385
3.0	LOW (350 CFM/TON)	ON	OFF	OFF	ON	CFM WATTS	1040 190	1010 220	1000 260	1000 310	990 340
	NORMAL (400 CFM/TON)	ON	OFF	OFF	OFF	CFM WATTS	1200 250	1200 320	1190 370	1190 415	1175 450
	HIGH (450 CFM/TON)	ON	OFF	ON	OFF	CFM WATTS	1340 355	1340 425	1330 475	1320 530	1300 570
3.5 **	LOW (350 CFM/TON)	OFF	OFF	OFF	ON	CFM WATTS	1215 265	1210 330	1210 375	1200 430	1185 465
	NORMAL ** (400 CFM/TON)	OFF	OFF	OFF	OFF	CFM WATTS	1430 415	1415 457	1410 520	1385 575	1330 580
	HIGH (450 CFM/TON)	OFF	OFF	ON	OFF	CFM WATTS	1430 415	1415 475	1410 520	1385 575	1330 580

NOTES:

- * First Letter may be "A" or "T"
- ** Factory setting
- Continuous Fan Setting: Heating or Cooling airflow is approximately 50% of selected Cooling value.
- LOW 350 cfm/ton is recommended for Variable Speed application for COMFORT & HUMID CLIMATE setting; NORMAL is 400 cfm/ton; HIGH 450 cfm/ton is for DRY CLIMATE setting

PRODUCT DATA

American Standard Heating & Air Conditioning

*UD2C080A9V4VB FURNACE HEATING AIRFLOW (CFM) AND POWER (WATTS) VS. EXTERNAL STATIC PRESSURE WITH FILTER									
	AIRFLOW SETTING	DIP SWITCH SETTING			EXTERNAL STATIC PRESSURE				
		SW 7	SW 8		0.1	0.3	0.5	0.7	0.9
HEATING 1ST STAGE	LOW	ON	ON	CFM TEMP. RISE WATTS	782 49 75	762 51 110	751 51 145	748 51 185	737 52 225
	MEDIUM **	ON	OFF	CFM TEMP. RISE WATTS	870 44 90	865 45 125	861 45 175	848 45 215	831 46 255
	HIGH	OFF	OFF	CFM TEMP. RISE WATTS	962 40 110	974 40 155	963 40 200	938 41 245	914 42 290
HEATING 2ND STAGE	LOW	ON	ON	CFM TEMP. RISE WATTS	1091 54 145	1092 54 190	1087 55 245	1092 54 305	1077 55 355
	MEDIUM **	ON	OFF	CFM TEMP. RISE WATTS	1211 49 190	1243 48 255	1243 48 310	1244 48 370	1235 48 430
	HIGH	OFF	OFF	CFM TEMP. RISE WATTS	1371 43 255	1388 43 325	1392 43 395	1385 43 455	1377 43 515

*UD2C080A9V4VB FURNACE COOLING AIRFLOW (CFM) AND POWER (WATTS) VS. EXTERNAL STATIC PRESSURE WITH FILTER											
OUTDOOR UNIT SIZE (TONS)	AIRFLOW SETTING	DIP SWITCH SETTING					EXTERNAL STATIC PRESSURE				
		SW 1	SW 2	SW 3	SW 4		0.1	0.3	0.5	0.7	0.9
2.5	LOW (350 CFM/TON)	ON	ON	OFF	ON	CFM WATTS	863 90	865 130	858 175	843 220	831 255
	NORMAL (400 CFM/TON)	ON	ON	OFF	OFF	CFM WATTS	995 115	1005 170	989 210	973 260	956 305
	HIGH (450 CFM/TON)	ON	ON	ON	OFF	CFM WATTS	1101 150	1112 200	1111 255	1107 305	1101 360
3.0	LOW (350 CFM/TON)	OFF	ON	OFF	ON	CFM WATTS	1031 125	1031 175	1026 215	1013 270	1003 320
	NORMAL (400 CFM/TON)	OFF	ON	OFF	OFF	CFM WATTS	1163 170	1178 230	1188 285	1183 345	1178 405
	HIGH (450 CFM/TON)	OFF	ON	ON	OFF	CFM WATTS	1319 240	1337 305	1344 365	1340 420	1336 485
3.5	LOW (350 CFM/TON)	ON	OFF	OFF	ON	CFM WATTS	1182 200	1206 240	1211 295	1211 350	1211 420
	NORMAL (400 CFM/TON)	ON	OFF	OFF	OFF	CFM WATTS	1380 255	1401 325	1402 390	1402 460	1399 515
	HIGH (450 CFM/TON)	ON	OFF	ON	OFF	CFM WATTS	1553 350	1566 425	1557 500	1558 560	1559 645
4 **	LOW (350 CFM/TON)	OFF	OFF	OFF	ON	CFM WATTS	1386 255	1401 330	1408 395	1402 460	1390 520
	NORMAL ** (400 CFM/TON)	OFF	OFF	OFF	OFF	CFM WATTS	1590 360	1593 440	1591 515	1588 575	1576 650
	HIGH (450 CFM/TON)	OFF	OFF	ON	OFF	CFM WATTS	1791 360	1808 615	1810 615	1808 775	1726 800

NOTES:

- * First Letter may be "A" or "T"
- ** Factory setting
- Continuous Fan Setting: Heating or Cooling airflow is approximately 50% of selected Cooling value.
- LOW 350 cfm/ton is recommended for Variable Speed application for COMFORT & HUMID CLIMATE setting; NORMAL is 400 cfm/ton; HIGH 450 cfm/ton is for DRY CLIMATE setting

*UD2C080B9V4VA FURNACE HEATING AIRFLOW (CFM) AND POWER (WATTS) VS. EXTERNAL STATIC PRESSURE WITH FILTER									
	AIRFLOW SETTING	DIP SWITCH SETTING			EXTERNAL STATIC PRESSURE				
		SW 7	SW 8		0.1	0.3	0.5	0.7	0.9
HEATING 1ST STAGE	LOW	ON	ON	CFM TEMP. RISE WATTS	974 49 133	968 49 285	949 50 202	925 51 254	906 52 304
	MEDIUM **	ON	OFF	CFM TEMP. RISE WATTS	1102 43 93	1112 43 144	1103 43 201	1083 44 255	1066 45 305
	HIGH	OFF	OFF	CFM TEMP. RISE WATTS	1194 40 119	1217 39 180	1215 39 243	1200 40 304	1182 40 362
HEATING 2ND STAGE	LOW	ON	ON	CFM TEMP. RISE WATTS	1189 58 142	1210 57 209	1209 57 276	1193 58 341	1175 58 404
	MEDIUM **	ON	OFF	CFM TEMP. RISE WATTS	1346 51 141	1388 49 207	1398 49 274	1390 49 339	1372 50 401
	HIGH	OFF	OFF	CFM TEMP. RISE WATTS	1460 47 186	1516 45 263	1536 45 335	1533 45 407	1515 45 477

*UD2C080B9V4VA FURNACE COOLING AIRFLOW (CFM) AND POWER (WATTS) VS. EXTERNAL STATIC PRESSURE WITH FILTER											
OUTDOOR UNIT SIZE (TONS)	AIRFLOW SETTING	DIP SWITCH SETTING					EXTERNAL STATIC PRESSURE				
		SW 1	SW 2	SW 3	SW 4		0.1	0.3	0.5	0.7	0.9
2.5	LOW (350 CFM/TON)	ON	ON	OFF	ON	CFM WATTS	842 71	819 114	789 163	756 207	740 249
	NORMAL (400 CFM/TON)	ON	ON	OFF	OFF	CFM WATTS	956 90	948 140	928 196	901 248	884 298
	HIGH (450 CFM/TON)	ON	ON	ON	OFF	CFM WATTS	1071 113	1078 171	1067 233	1045 292	1028 348
3.0	LOW (350 CFM/TON)	OFF	ON	OFF	ON	CFM WATTS	1002 99	1000 152	983 210	958 265	942 318
	NORMAL (400 CFM/TON)	OFF	ON	OFF	OFF	CFM WATTS	1140 128	1155 191	1150 256	1132 319	1114 379
	HIGH (450 CFM/TON)	OFF	ON	ON	OFF	CFM WATTS	1278 165	1311 238	1316 308	1305 377	1287 444
3.5	LOW (350 CFM/TON)	ON	OFF	OFF	ON	CFM WATTS	1163 134	1181 199	1177 265	1161 328	1143 389
	NORMAL (400 CFM/TON)	ON	OFF	OFF	OFF	CFM WATTS	1324 179	1363 255	1372 326	1363 397	1345 466
	HIGH (450 CFM/TON)	ON	OFF	ON	OFF	CFM WATTS	1485 234	1544 319	1566 396	1565 472	1546 550
4 **	LOW (350 CFM/TON)	OFF	OFF	OFF	ON	CFM WATTS	1324 179	1363 255	1372 326	1363 397	1345 466
	NORMAL ** (400 CFM/TON)	OFF	OFF	OFF	OFF	CFM WATTS	1508 243	1570 329	1594 407	1593 483	1575 562
	HIGH (450 CFM/TON)	OFF	OFF	ON	OFF	CFM WATTS	1691 322	1777 416	1816 499	1824 579	1805 669

NOTES:

- * First Letter may be "A" or "T"
- ** Factory setting
- Continuous Fan Setting: Heating or Cooling airflow is approximately 50% of selected Cooling value.
- LOW 350 cfm/ton is recommended for Variable Speed application for COMFORT & HUMID CLIMATE setting; NORMAL is 400 cfm/ton; HIGH 450 cfm/ton is for DRY CLIMATE setting

PRODUCT DATA

American Standard Heating & Air Conditioning

*UD2B100A9V3VB FURNACE HEATING AIRFLOW (CFM) AND POWER (WATTS) VS. EXTERNAL STATIC PRESSURE WITH FILTER									
	AIRFLOW SETTING	DIP SWITCH SETTING			EXTERNAL STATIC PRESSURE				
		SW 7	SW 8		0.1	0.3	0.5	0.7	0.9
HEATING 1ST STAGE	LOW	ON	ON	CFM TEMP. RISE WATTS	751 64 86	796 61 132	817 59 175	832 58 218	838 57 263
	MEDIUM **	ON	OFF	CFM TEMP. RISE WATTS	862 56 121	921 52 185	953 51 233	967 50 285	954 50 322
	HIGH	OFF	OFF	CFM TEMP. RISE WATTS	959 50 148	1002 48 210	1036 46 280	1036 46 325	1003 48 355
HEATING 2ND STAGE	LOW	ON	ON	CFM TEMP. RISE WATTS	1099 67 227	1124 66 287	1149 64 355	1157 64 415	1055 70 395
	MEDIUM **	ON	OFF	CFM TEMP. RISE WATTS	1286 58 365	1321 56 450	1313 56 455	1215 61 475	1119 66 450
	HIGH	OFF	OFF	CFM TEMP. RISE WATTS	1399 53 465	1419 52 570	1347 55 545	1265 59 520	1163 64 485

*UD2B100A9V3VB FURNACE COOLING AIRFLOW (CFM) AND POWER (WATTS) VS. EXTERNAL STATIC PRESSURE WITH FILTER											
OUTDOOR UNIT SIZE (TONS)	AIRFLOW SETTING	DIP SWITCH SETTING					EXTERNAL STATIC PRESSURE				
		SW 1	SW 2	SW 3	SW 4		0.1	0.3	0.5	0.7	0.9
1.5	LOW (350 CFM/TON)	ON	ON	OFF	ON	CFM WATTS	516 50	536 75	551 105	547 135	530 165
	NORMAL (400 CFM/TON)	ON	ON	OFF	OFF	CFM WATTS	583 59	615 92	633 127	621 157	618 18
	HIGH (450 CFM/TON)	ON	ON	ON	OFF	CFM WATTS	681 70	697 110	701 140	709 180	712 215
2.0	LOW (350 CFM/TON)	OFF	ON	OFF	ON	CFM WATTS	680 75	726 120	735 150	741 190	745 230
	NORMAL (400 CFM/TON)	OFF	ON	OFF	OFF	CFM WATTS	769 103	819 145	843 190	858 235	865 286
	HIGH (450 CFM/TON)	OFF	ON	ON	OFF	CFM WATTS	882 130	938 190	961 245	975 300	970 345
2.5	LOW (350 CFM/TON)	ON	OFF	OFF	ON	CFM WATTS	831 180	903 180	928 230	935 275	935 320
	NORMAL (400 CFM/TON)	ON	OFF	OFF	OFF	CFM WATTS	979 167	1036 240	1053 295	1053 345	1015 368
	HIGH (450 CFM/TON)	ON	OFF	ON	OFF	CFM WATTS	1121 245	1147 310	1176 383	1167 442	1055 396
3.0**	LOW (350 CFM/TON)	OFF	OFF	OFF	ON	CFM WATTS	1061 210	1081 265	1095 320	1101 382	1032 380
	NORMAL ** (400 CFM/TON)	OFF	OFF	OFF	OFF	CFM WATTS	1185 278	1223 364	1251 435	1205 455	1101 426
	HIGH (450 CFM/TON)	OFF	OFF	ON	OFF	CFM WATTS	1351 425	1372 503	1343 535	1248 505	1168 480

NOTES:

- * First Letter may be "A" or "T"
- ** Factory setting
- Continuous Fan Setting: Heating or Cooling airflow is approximately 50% of selected Cooling value.
- LOW 350 cfm/ton is recommended for Variable Speed application for COMFORT & HUMID CLIMATE setting; NORMAL is 400 cfm/ton; HIGH 450 cfm/ton is for DRY CLIMATE setting

*UD2C100A9V5VB FURNACE HEATING AIRFLOW (CFM) AND POWER (WATTS) VS. EXTERNAL STATIC PRESSURE WITH FILTER									
	AIRFLOW SETTING	DIP SWITCH SETTING			EXTERNAL STATIC PRESSURE				
		SW 7	SW 8		0.1	0.3	0.5	0.7	0.9
HEATING 1ST STAGE	LOW	ON	ON	CFM TEMP. RISE WATTS	900 53 100	890 54 130	870 55 175	850 57 220	835 58 270
	MEDIUM **	ON	OFF	CFM TEMP. RISE WATTS	1125 43 150	1090 44 200	1060 46 235	1070 45 300	1070 45 340
	HIGH	OFF	OFF	CFM TEMP. RISE WATTS	1300 37 220	1300 37 290	1320 36 365	1350 36 430	1340 36 490
HEATING 2ND STAGE	LOW	ON	ON	CFM TEMP. RISE WATTS	1270 59 200	1290 58 260	1290 58 335	1290 58 400	1280 58 460
	MEDIUM **	ON	OFF	CFM TEMP. RISE WATTS	1575 47 355	1600 46 445	1610 46 520	1600 46 575	1580 47 650
	HIGH	OFF	OFF	CFM TEMP. RISE WATTS	1870 40 560	1890 39 665	1860 40 710	1870 40 830	1730 43 760

*UD2C100A9V5VB FURNACE COOLING AIRFLOW (CFM) AND POWER (WATTS) VS. EXTERNAL STATIC PRESSURE WITH FILTER											
OUTDOOR UNIT SIZE (TONS)	AIRFLOW SETTING	DIP SWITCH SETTING					EXTERNAL STATIC PRESSURE				
		SW 1	SW 2	SW 3	SW 4		0.1	0.3	0.5	0.7	0.9
3.0	LOW (350 CFM/TON)	ON	ON	OFF	ON	CFM WATTS	1075 135	1055 185	1015 220	1000 265	990 325
	NORMAL (400 CFM/TON)	ON	ON	OFF	OFF	CFM WATTS	1220 185	1200 240	1210 295	1210 350	1210 410
	HIGH (450 CFM/TON)	ON	ON	ON	OFF	CFM WATTS	1390 245	1390 320	1410 391	1410 470	1400 510
3.5	LOW (350 CFM/TON)	OFF	ON	OFF	ON	CFM WATTS	1214 185	1210 240	1215 295	1210 350	1210 415
	NORMAL (400 CFM/TON)	OFF	ON	OFF	OFF	CFM WATTS	1430 310	1460 355	1470 430	1460 500	1440 555
	HIGH (450 CFM/TON)	OFF	ON	ON	OFF	CFM WATTS	1640 370	1665 460	1650 540	1640 615	1610 660
4.0	LOW (350 CFM/TON)	ON	OFF	OFF	ON	CFM WATTS	1405 270	1430 310	1440 375	1440 480	1420 550
	NORMAL (400 CFM/TON)	ON	OFF	OFF	OFF	CFM WATTS	1670 395	1675 490	1670 550	1655 630	1630 700
	HIGH (450 CFM/TON)	ON	OFF	ON	OFF	CFM WATTS	1870 540	1880 635	1880 730	1845 800	1670 640
5.0 **	LOW (350 CFM/TON)	OFF	OFF	OFF	ON	CFM WATTS	1775 480	1800 580	1820 680	1800 750	1680 740
	NORMAL ** (400 CFM/TON)	OFF	OFF	OFF	OFF	CFM WATTS	2065 755	2020 840	1945 900	1805 880	1623 800
	HIGH (450 CFM/TON)	OFF	OFF	ON	OFF	CFM WATTS	2310 1000	2100 1000	2100 950	1965 890	1800 825

NOTES:

- * First letter may be "A" or "T"
- ** Factory setting
- Continuous Fan Setting: Heating or Cooling airflow is approximately 50% of selected Cooling value.
- LOW 350 cfm/ton is recommended for Variable Speed application for COMFORT & HUMID CLIMATE setting; NORMAL is 400 cfm/ton; HIGH 450 cfm/ton is for DRY CLIMATE setting

PRODUCT DATA

American Standard Heating & Air Conditioning

*UD2C100B9V5VA FURNACE HEATING AIRFLOW (CFM) AND POWER (WATTS) VS. EXTERNAL STATIC PRESSURE WITH FILTER									
	AIRFLOW SETTING	DIP SWITCH SETTING			EXTERNAL STATIC PRESSURE				
		SW 7	SW 8		0.1	0.3	0.5	0.7	0.9
HEATING 1ST STAGE	LOW	ON	ON	CFM TEMP. RISE WATTS	953 50 93	944 50 146	936 51 193	908 52 243	887 54 292
	MEDIUM **	ON	OFF	CFM TEMP. RISE WATTS	1142 42 135	1141 42 200	1135 42 255	1112 43 322	1098 43 377
	HIGH	OFF	OFF	CFM TEMP. RISE WATTS	1258 38 169	1260 38 240	1256 38 302	1236 38 378	1227 39 437
HEATING 2ND STAGE	LOW	ON	ON	CFM TEMP. RISE WATTS	1312 52 188	1317 52 261	1314 52 326	1294 53 406	1287 53 468
	MEDIUM **	ON	OFF	CFM TEMP. RISE WATTS	1577 44 301	1592 43 387	1592 43 468	1597 43 563	1582 43 644
	HIGH	OFF	OFF	CFM TEMP. RISE WATTS	1739 39 392	1761 39 486	1762 39 575	1753 39 675	1762 39 774

*UD2C100B9V5VA FURNACE COOLING AIRFLOW (CFM) AND POWER (WATTS) VS. EXTERNAL STATIC PRESSURE WITH FILTER											
OUTDOOR UNIT SIZE (TONS)	AIRFLOW SETTING	DIP SWITCH SETTING					EXTERNAL STATIC PRESSURE				
		SW 1	SW 2	SW 3	SW 4		0.1	0.3	0.5	0.7	0.9
3.0	LOW (350 CFM/TON)	ON	ON	OFF	ON	CFM WATTS	1056 114	1050 173	1044 225	1019 284	1002 336
	NORMAL (400 CFM/TON)	ON	ON	OFF	OFF	CFM WATTS	1199 151	1199 219	1194 277	1172 349	1161 405
	HIGH (450 CFM/TON)	ON	ON	ON	OFF	CFM WATTS	1342 198	1348 273	1345 340	1326 422	1320 486
3.5	LOW (350 CFM/TON)	OFF	ON	OFF	ON	CFM WATTS	1223 158	1224 227	1219 287	1198 361	1187 418
	NORMAL (400 CFM/TON)	OFF	ON	OFF	OFF	CFM WATTS	1389 217	1397 294	1395 363	1377 449	1373 515
	HIGH (450 CFM/TON)	OFF	ON	ON	OFF	CFM WATTS	1556 291	1570 376	1570 455	1556 549	1559 629
4.0	LOW (350 CFM/TON)	ON	OFF	OFF	ON	CFM WATTS	1389 217	1397 294	1395 363	1377 449	1373 515
	NORMAL (400 CFM/TON)	ON	OFF	OFF	OFF	CFM WATTS	1580 303	1595 389	1595 469	1582 565	1585 647
	HIGH (450 CFM/TON)	ON	OFF	ON	OFF	CFM WATTS	1770 411	1793 507	1795 598	1787 698	1797 801
5.0 **	LOW (350 CFM/TON)	OFF	OFF	OFF	ON	CFM WATTS	1723 382	1744 475	1754 564	1735 663	1744 760
	NORMAL ** (400 CFM/TON)	OFF	OFF	OFF	OFF	CFM WATTS	1961 546	1991 652	1996 751	1991 850	2010 981
	HIGH (450 CFM/TON)	OFF	OFF	ON	OFF	CFM WATTS	2199 754	2217 875	2217 983	2197 1067	1987 943

NOTES:

- * First letter may be "A" or "T"
- ** Factory setting
- Continuous Fan Setting: Heating or Cooling airflow is approximately 50% of selected Cooling value.
- LOW 350 cfm/ton is recommended for Variable Speed application for COMFORT & HUMID CLIMATE setting; NORMAL is 400 cfm/ton; HIGH 450 cfm/ton is for DRY CLIMATE setting

*UD2D120A9V5VB FURNACE HEATING AIRFLOW (CFM) AND POWER (WATTS) VS. EXTERNAL STATIC PRESSURE WITH FILTER									
	AIRFLOW SETTING	DIP SWITCH SETTING			EXTERNAL STATIC PRESSURE				
		SW7	SW8		0.1	0.3	0.5	0.7	0.9
HEATING 1ST STAGE	LOW	ON	ON	CFM TEMP. RISE WATTS	1007 57 114	1062 54 177	1084 53 285	1063 54 303	1063 54 350
	MEDIUM **	ON	OFF	CFM TEMP. RISE WATTS	1154 50 167	1211 48 230	1211 48 277	1221 47 344	1212 48 417
	HIGH	OFF	OFF	CFM TEMP. RISE WATTS	1288 45 208	1319 44 273	1310 44 330	1349 43 410	1358 43 460
HEATING 2ND STAGE	LOW	ON	ON	CFM TEMP. RISE WATTS	1387 64 250	1421 63 320	1455 61 400	1488 60 460	1495 59 540
	MEDIUM **	ON	OFF	CFM TEMP. RISE WATTS	1589 56 350	1637 54 440	1666 53 535	1678 53 600	1541 58 575
	HIGH	OFF	OFF	CFM TEMP. RISE WATTS	1771 50 475	1788 50 560	1804 49 650	1751 51 675	1554 57 590

*UD2D120A9V5VB FURNACE COOLING AIRFLOW (CFM) AND POWER (WATTS) VS. EXTERNAL STATIC PRESSURE WITH FILTER											
OUTDOOR UNIT SIZE (TONS)	AIRFLOW SETTING (See Notes)	DIP SWITCH SETTING					EXTERNAL STATIC PRESSURE				
		SW1	SW2	SW3	SW4		0.1	0.3	0.5	0.7	0.9
3.5	LOW (350 CFM/ TON)	OFF	ON	OFF	ON	CFM WATTS	1195 150	1243 225	1235 275	1251 325	1251 410
	NORMAL (400 CFM/ TON)	OFF	ON	OFF	OFF	CFM WATTS	1353 210	1403 290	1417 370	1437 425	1458 485
	HIGH (450 CFM/ TON)	OFF	ON	ON	OFF	CFM WATTS	1554 315	1572 410	1615 480	1634 570	1567 575
4	LOW (350 CFM/ TON)	ON	OFF	OFF	ON	CFM WATTS	1356 200	1391 280	1399 370	1433 420	1454 510
	NORMAL (400 CFM/ TON)	ON	OFF	OFF	OFF	CFM WATTS	1565 320	1584 410	1633 475	1639 560	1554 575
	HIGH (450 CFM/ TON)	ON	OFF	ON	OFF	CFM WATTS	1766 450	1799 550	1810 650	1784 685	1590 600
5 **	LOW (350 CFM/ TON)	OFF	OFF	OFF	ON	CFM WATTS	1708 420	1758 530	1759 585	1775 675	1575 585
	NORMAL ** (400 CFM/ TON)	OFF	OFF	OFF	OFF	CFM WATTS	1994 665	2018 775	1971 785	1814 725	1618 625
	HIGH (450 CFM/ TON)	OFF	OFF	ON	OFF	CFM WATTS	2247 975	2152 925	2019 860	1861 765	1693 680

NOTES: "CONTINUOUS FAN SETTING" IS THERMOSTAT FAN SWITCH "ON" AND DIP SWITCHES 5 AND 6 "ON".

1. *FIRST LETTER MAY BE "A" OR "T"

2. **FACTORY SETTING.

3. CONTINUOUS FAN SETTING: HEATING OR COOLING AIRFLOW IS APPROXIMATELY 50% OF SELECTED COOLING VALUE.

4. LOW 350 CFM/TON IS RECOMMENDED FOR VARIABLE SPEED APPLICATION FOR COMFORT & HUMID CLIMATE SETTING: NORMAL IS 400 CFM/TON: HIGH 450 CFM/TON IS FOR DRY CLIMATE SETTING.

PRODUCT DATA

American Standard Heating & Air Conditioning

*UD2D120B9V5VA FURNACE HEATING AIRFLOW (CFM) AND POWER (WATTS) VS. EXTERNAL STATIC PRESSURE WITH FILTER									
	AIRFLOW SETTING	DIP SWITCH SETTING			EXTERNAL STATIC PRESSURE				
		SW7	SW8		0.1	0.3	0.5	0.7	0.9
HEATING 1ST STAGE	LOW	ON	ON	CFM TEMP. RISE WATTS	1050 45 99	1044 46 146	1035 46 208	1005 47 252	980 48 310
	MEDIUM **	ON	OFF	CFM TEMP. RISE WATTS	1214 39 129	1216 39 188	1217 39 262	1192 40 252	1169 41 310
	HIGH	OFF	OFF	CFM TEMP. RISE WATTS	1288 37 147	1293 37 212	1298 37 293	1275 37 309	1254 38 373
HEATING 2ND STAGE	LOW	ON	ON	CFM TEMP. RISE WATTS	1429 48 191	1440 48 267	1453 47 363	1435 48 340	1416 48 406
	MEDIUM **	ON	OFF	CFM TEMP. RISE WATTS	1672 41 310	1695 40 402	1722 40 528	1711 40 409	1697 40 480
	HIGH	OFF	OFF	CFM TEMP. RISE WATTS	1782 39 385	1809 38 480	1890 36 623	1835 37 565	1871 37 644

*UD2D120B9V5VA FURNACE COOLING AIRFLOW (CFM) AND POWER (WATTS) VS. EXTERNAL STATIC PRESSURE WITH FILTER											
OUTDOOR UNIT SIZE (TONS)	AIRFLOW SETTING (See Notes)	DIP SWITCH SETTING					EXTERNAL STATIC PRESSURE				
		SW1	SW2	SW3	SW4		0.1	0.3	0.5	0.7	0.9
3.5	LOW (350 CFM/ TON)	OFF	ON	OFF	ON	CFM WATTS	1208 128	1209 186	1210 260	1185 306	1162 370
	NORMAL (400 CFM/ TON)	OFF	ON	OFF	OFF	CFM WATTS	1343 162	1350 232	1358 318	1337 365	1317 433
	HIGH (450 CFM/ TON)	OFF	ON	ON	OFF	CFM WATTS	1477 210	1491 290	1507 391	1490 436	1472 508
4	LOW (350 CFM/ TON)	ON	OFF	OFF	ON	CFM WATTS	1343 162	1350 232	1358 318	1337 365	1317 433
	NORMAL (400 CFM/ TON)	ON	OFF	OFF	OFF	CFM WATTS	1496 218	1511 300	1528 403	1511 447	1494 520
	HIGH (450 CFM/ TON)	ON	OFF	ON	OFF	CFM WATTS	1650 296	1671 387	1698 511	1686 548	1671 626
5 **	LOW (350 CFM/ TON)	OFF	OFF	OFF	ON	CFM WATTS	1612 274	1631 363	1655 482	1642 521	1627 598
	NORMAL ** (400 CFM/ TON)	OFF	OFF	OFF	OFF	CFM WATTS	1858 403	1880 497	1890 644	1860 670	1871 755
	HIGH (450 CFM/ TON)	OFF	OFF	ON	OFF	CFM WATTS	1871 585	1880 672	1890 852	2109 853	1871 953

NOTES: "CONTINUOUS FAN SETTING" IS THERMOSTAT FAN SWITCH "ON" AND DIP SWITCHES 5 AND 6 "ON".

1. *FIRST LETTER MAY BE "A" OR "T"

2. **FACTORY SETTING.

3. CONTINUOUS FAN SETTING: HEATING OR COOLING AIRFLOW IS APPROXIMATELY 50% OF SELECTED COOLING VALUE.

4. LOW 350 CFM/TON IS RECOMMENDED FOR VARIABLE SPEED APPLICATION FOR COMFORT & HUMID CLIMATE SETTING: NORMAL IS 400 CFM/TON: HIGH 450 CFM/TON IS FOR DRY CLIMATE SETTING.

*UD2D140A9V5VB FURNACE HEATING AIRFLOW (CFM) AND POWER (WATTS) VS. EXTERNAL STATIC PRESSURE WITH FILTER									
	AIRFLOW SETTING	DIP SWITCH SETTING			EXTERNAL STATIC PRESSURE				
		SW 7	SW 8		0.1	0.3	0.5	0.7	0.9
HEATING 1ST STAGE	LOW	ON	ON	CFM TEMP. RISE WATTS	1090 62 130	1100 61 175	1070 63 215	1080 62 255	1060 63 290
	MEDIUM **	ON	OFF	CFM TEMP. RISE WATTS	1230 55 180	1265 53 235	1280 53 315	1300 52 380	1300 52 455
	HIGH	OFF	OFF	CFM TEMP. RISE WATTS	1380 49 235	1405 48 290	1425 47 375	1430 47 415	1450 47 520
HEATING 2ND STAGE	LOW	ON	ON	CFM TEMP. RISE WATTS	1545 67 320	1550 67 385	1560 67 475	1560 67 540	1575 66 605
	MEDIUM **	ON	OFF	CFM TEMP. RISE WATTS	1760 59 435	1790 58 545	1810 58 620	1800 58 695	1725 60 725
	HIGH	OFF	OFF	CFM TEMP. RISE WATTS	2000 52 615	2010 52 715	2000 52 790	1950 54 820	1800 58 775

*UD2D140A9V5VB FURNACE COOLING AIRFLOW (CFM) AND POWER (WATTS) VS. EXTERNAL STATIC PRESSURE WITH FILTER											
OUTDOOR UNIT SIZE (TONS)	AIRFLOW SETTING	DIP SWITCH SETTING					EXTERNAL STATIC PRESSURE				
		SW 1	SW 2	SW 3	SW 4		0.1	0.3	0.5	0.7	0.9
3.5	LOW (350 CFM/TON)	OFF	ON	OFF	ON	CFM WATTS	1175 165	1165 200	1180 265	1170 320	1150 400
	NORMAL (400 CFM/TON)	OFF	ON	OFF	OFF	CFM WATTS	1345 225	1370 285	1400 360	1405 440	1380 490
	HIGH (450 CFM/TON)	OFF	ON	ON	OFF	CFM WATTS	1525 295	1565 390	1585 470	1575 515	1530 585
4.0	LOW (350 CFM/TON)	ON	OFF	OFF	ON	CFM WATTS	1320 220	1330 275	1335 355	1300 435	1240 490
	NORMAL (400 CFM/TON)	ON	OFF	OFF	OFF	CFM WATTS	1550 310	1580 400	1590 475	1555 540	1460 610
	HIGH (450 CFM/TON)	ON	OFF	ON	OFF	CFM WATTS	1735 430	1735 510	1710 600	1670 675	1590 710
5.0 **	LOW (350 CFM/TON)	OFF	OFF	OFF	ON	CFM WATTS	1700 415	1725 470	1730 560	1725 640	1690 700
	NORMAL ** (400 CFM/TON)	OFF	OFF	OFF	OFF	CFM WATTS	1980 616	1980 710	1950 770	1885 780	1735 735
	HIGH (450 CFM/TON)	OFF	OFF	ON	OFF	CFM WATTS	2190 835	2150 870	2075 890	1905 800	1735 735

NOTES:

- * First Letter may be "A" or "T"
- ** Factory setting
- Continuous Fan Setting: Heating or Cooling airflow is approximately 50% of selected Cooling value.
- LOW 350 cfm/ton is recommended for Variable Speed application for COMFORT & HUMID CLIMATE setting; NORMAL is 400 cfm/ton; HIGH 450 cfm/ton is for DRY CLIMATE setting

WIRING DIAGRAM

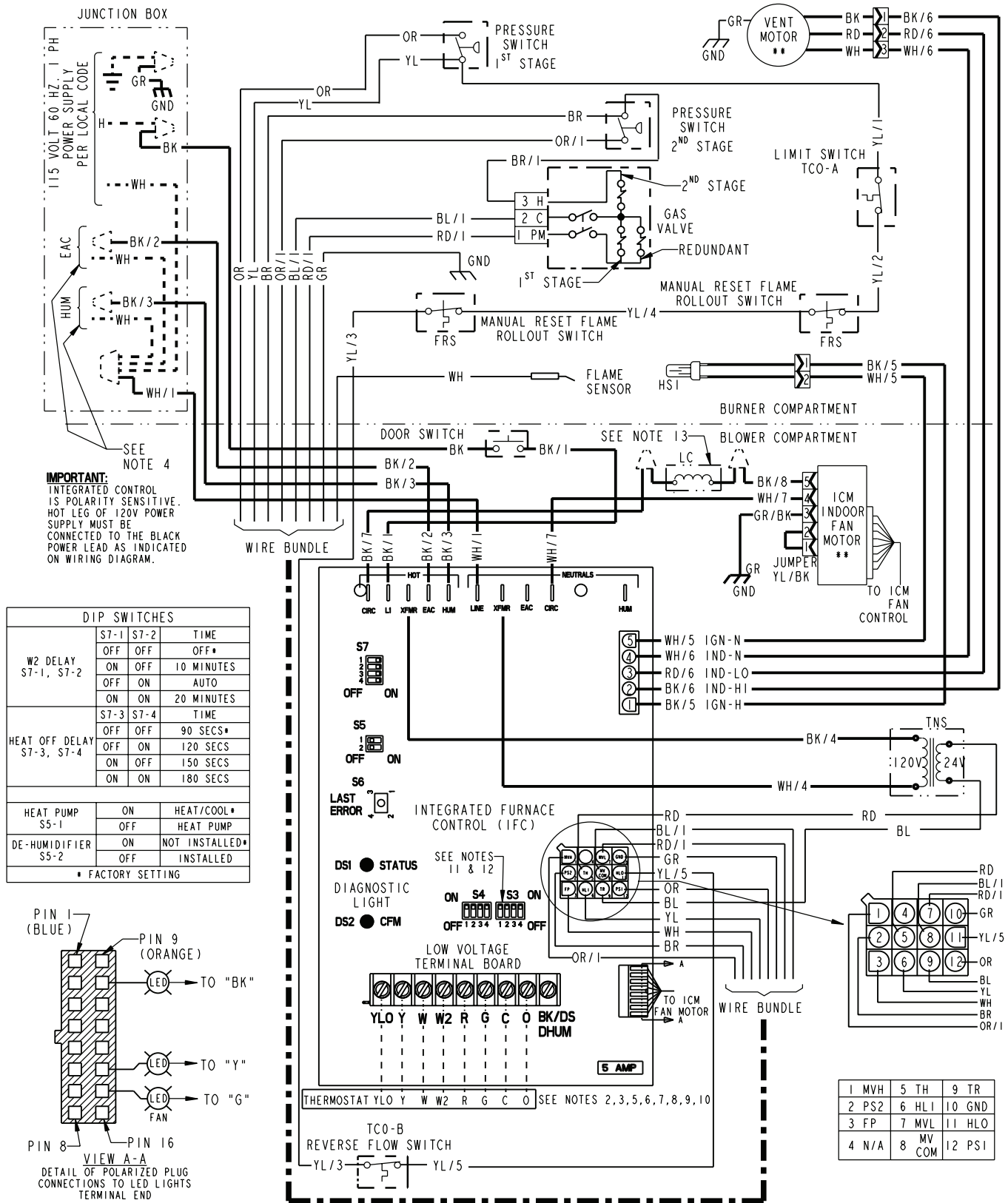

From Dwg. D344249P02

SCHMATIC DIAGRAMS

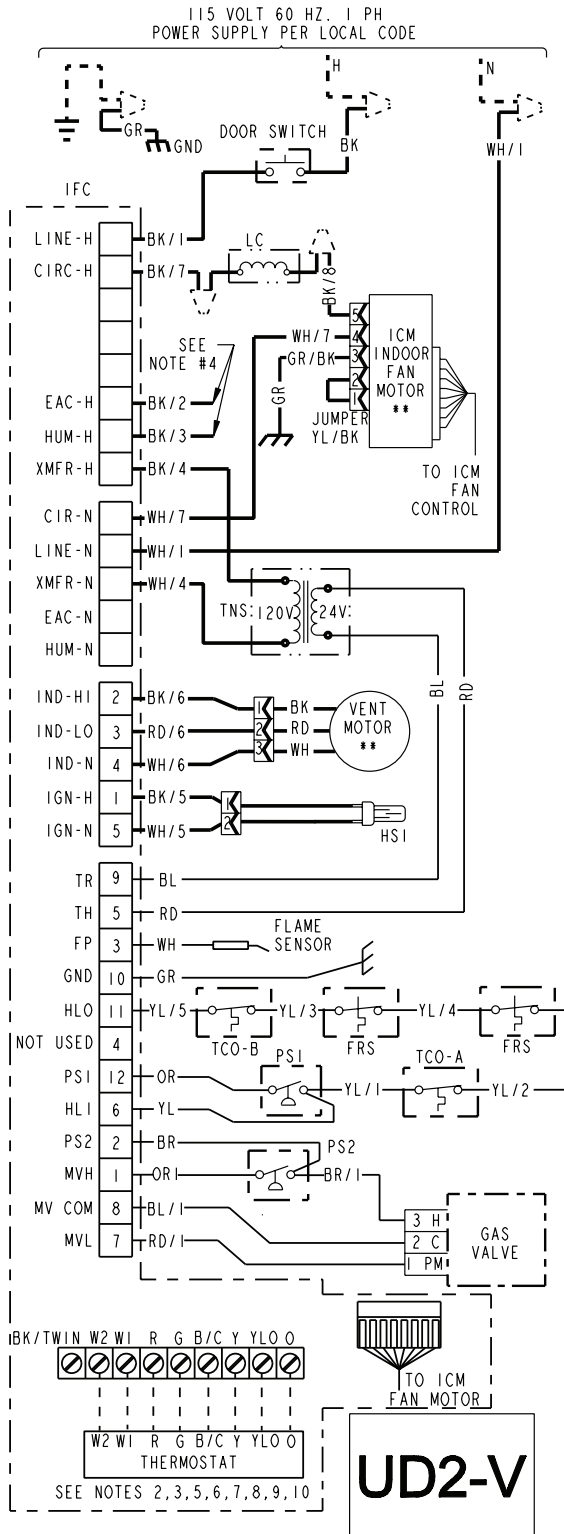

TABLE "A"

MODELS

- UD2B060A9V3V••
- UD2B080A9V3V••
- UD2C080A9V4V••
- UD2C080B9V4V••
- UD2B100A9V3V••
- UD2C100A9V5V••
- UD2C100B9V5V••
- UD2D120A9V5V••
- UD2D120B9V5V••
- UD2D140A9V5V••

• PREFIX MAY BE "A" OR "T"
• SUFFIX MAY BE "A" THROUGH "Z"

INTEGRATED FURNACE CONTROL
REPLACE WITH PART CNT06015 OR EQUIVALENT

ELECTRICAL RATING
INPUT: 25 VAC, 60 HZ.
XFMR SEC. CURRENT: 450 MA.
MV 1ST STAGE OUTPUT: 1.5 A @ 24 VAC
MV 2ND STAGE OUTPUT: 0.5 A @ 24 VAC
IND OUTPUT: 2.2 FLA, 3.5 LRA @ 120 VAC
CIRC. BLOWER OUTPUT: 14.5 FLA, 25 LRA @ 120 VAC
HUMIDIFIER & AIR CLEANER
MAX. LOAD: 1.0 A @ 120 VAC
IGNITER OUTPUT: 2.0 A @ 120 VAC

TIMINGS
IGN WARMUP: 20 SEC.
RETRIES: 2 RECYCLES: 10
HEAT ON DELAY: 45 SEC.
COOL ON DELAY: 2 SEC.

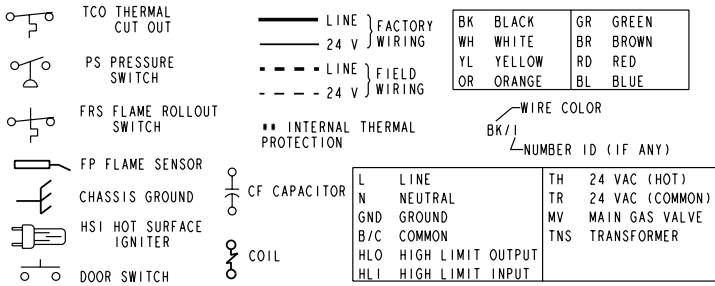

- NOTES:**
- IF ANY OF THE ORIGINAL WIRING AS SUPPLIED WITH THIS FURNACE MUST BE REPLACED, IT MUST BE WITH WIRE HAVING A TEMPERATURE RATING OF AT LEAST 105 C.
 - THERMOSTAT HEAT ANTICIPATOR SETTING: FIRST STAGE .38 AMPS, SECOND STAGE .13 AMPS. IF SETTING IS NOT FIXED ON THERMOSTAT, FOR SINGLE STAGE HEATING THERMOSTAT SET AT .51 AMPS.
 - FOR PROPER OPERATION OF COOLING SPEED, "Y" TERMINAL MUST BE CONNECTED TO THE ROOM THERMOSTAT.
 - THESE LEADS PROVIDE 120V POWER CONNECTIONS FOR ELECTRONIC AIR CLEANER (EAC) AND HUMIDIFIER (HUM). MAX. LOAD: 1.0 AMPS EACH.
 - WHEN USING A SINGLE STAGE HEATING THERMOSTAT, THE 2ND STAGE HEAT DELAY IS CONTROLLED BY S7-1 & S7-2. REFERENCE THE SERVICE FACTS FOR DIP SWITCH CONFIGURATIONS.
 - GREEN LIGHT (CFM) FLASHES ONCE PER 100 CFM COMMAND.
 - FOR HEAT PUMP SYSTEMS Y AND O MUST BE CONNECTED TO THE LOW-VOLTAGE TERMINAL BOARD.
 - FOR TWO COMPRESSOR SYSTEMS, USE "YLO" FOR LOW SPEED AND "Y" FOR HIGH SPEED CONNECTION TO THE LOW-VOLTAGE TERMINAL BOARD. FOR TWO STEP SCROLL SYSTEM, USE "Y" FOR LOW SPEED AND "BK" FOR HIGH SPEED CONNECTIONS ON THE LOW VOLTAGE TERMINAL BOARD. PLACE A JUMPER BETWEEN "R" AND "O" AND MOVE "S5-2" TO THE "OFF" POSITION.
 - OPTIONAL HUMIDISTAT IS TO BE CONNECTED BETWEEN "R" & "BK". **DO NOT CUT ANY JUMPERS ON THIS BOARD.** SWITCH "S5-2" MUST BE SET IN THE "OFF" POSITION IF HUMIDISTAT IS USED. THE "S5-2" SWITCH MUST ALSO BE TURNED TO "OFF" WHEN APPLYING AN AIRFLOW COMMAND SIGNAL TO "BK". THE "BK" TERMINAL MUST BE USED WHEN APPLYING A HUMIDISTAT, A 402 THERMOSTAT (WITH "BK" ENABLED), A TWO STEP SCROLL COMPRESSOR OR RESIDENTIAL ZONING SYSTEM.
 - A JUMPER MUST BE PLACED BETWEEN "R" & "O" TO ENABLE THE "BK" CIRCUIT OR ENHANCED MODE (COMFORT R). THIS "R" TO "O" JUMPER MUST BE IN PLACE FOR HUMIDISTAT DEHUMIDIFICATION AND PROPER BLOWER OPERATION WITH A TWO STEP SCROLL COMPRESSOR.
 - SEE INDOOR MOTOR AIRFLOW SELECTION CHART, LOCATED IN THE FURNACE FOR DIP SWITCH SETTINGS TO SET AIRFLOW AND COOLING OFF DELAYS.
 - POWER MUST BE OFF WHEN DIP SWITCHES ARE SET.
 - USED ON ALL DOWNFLOW VARIABLE SPEED MODELS EXCEPT FOR •DD2B060A9V3V•• AND •DD2B080A9V3V••.

WARNING

HAZARDOUS VOLTAGE:
DISCONNECT ALL ELECTRICAL POWER INCLUDING REMOTE DISCONNECTS BEFORE SERVICING.
FAILURE TO DISCONNECT POWER BEFORE SERVICING CAN CAUSE SEVERE PERSONAL INJURY OR DEATH.

CAUTION

USE COPPER CONDUCTORS ONLY!
UNIT TERMINALS ARE NOT DESIGNED TO ACCEPT OTHER TYPES OF CONDUCTORS.
FAILURE TO DO SO MAY CAUSE DAMAGE TO THE EQUIPMENT.

DIAGNOSTIC CODES

RED LED FLASH:
1 FLASH : FLAME SENSED WHEN NO FLAME SHOULD BE PRESENT
2 FLASHES: PRESSURE SWITCH STUCK CLOSED
3 FLASHES: 1ST-STAGE PRESSURE SWITCH STUCK OPEN/ NOT CLOSING
4 FLASHES: OPEN THERMAL LIMIT OR OPEN ROLLOUT
5 FLASHES: OPEN LOW VOLTAGE FUSE
6 FLASHES: 1ST STAGE PRESSURE SWITCH OPENED 5 TIMES WITHIN ONE CYCLE --1 HOUR LOCKOUT
7 FLASHES: SYSTEM LOCKOUT (RETRY)
8 FLASHES: SYSTEM LOCKOUT (RECYCLE)
9 FLASHES: REVERSE POLARITY OR POOR GROUNDING
10 FLASHES: GAS VALVE ENERGIZED WITH NO CALL FOR HEAT
12 FLASHES: IGNITOR RELAY FAILURE INTERNAL IN BOARD. REPLACE "IFC"
SOLID :GAS VALVE RELAY FAILURE INTERNAL IN BOARD. REPLACE "IFC"

3 DOUBLE: 2ND STAGE PRESSURE SWITCH OPEN SYSTEM REVERTS TO 1ST STAGE HEAT

AMBER LED FLASH:
1 FLASH : 1ST STAGE CALL FOR HEAT
2 FLASHES: 2ND STAGE CALL FOR HEAT
3 FLASHES: W2 CALL PRESENT WITH NO W1
4 FLASHES: Y PRESENT WITH NO G CALL
RAPID : LOW FLAME SENSE CURRENT
GREEN LED FLASH:
1 FLASH: STANDBY MODE OF CALL FOR COOLING

FIELD WIRING DIAGRAM FOR SINGLE STAGE HEATING ONLY

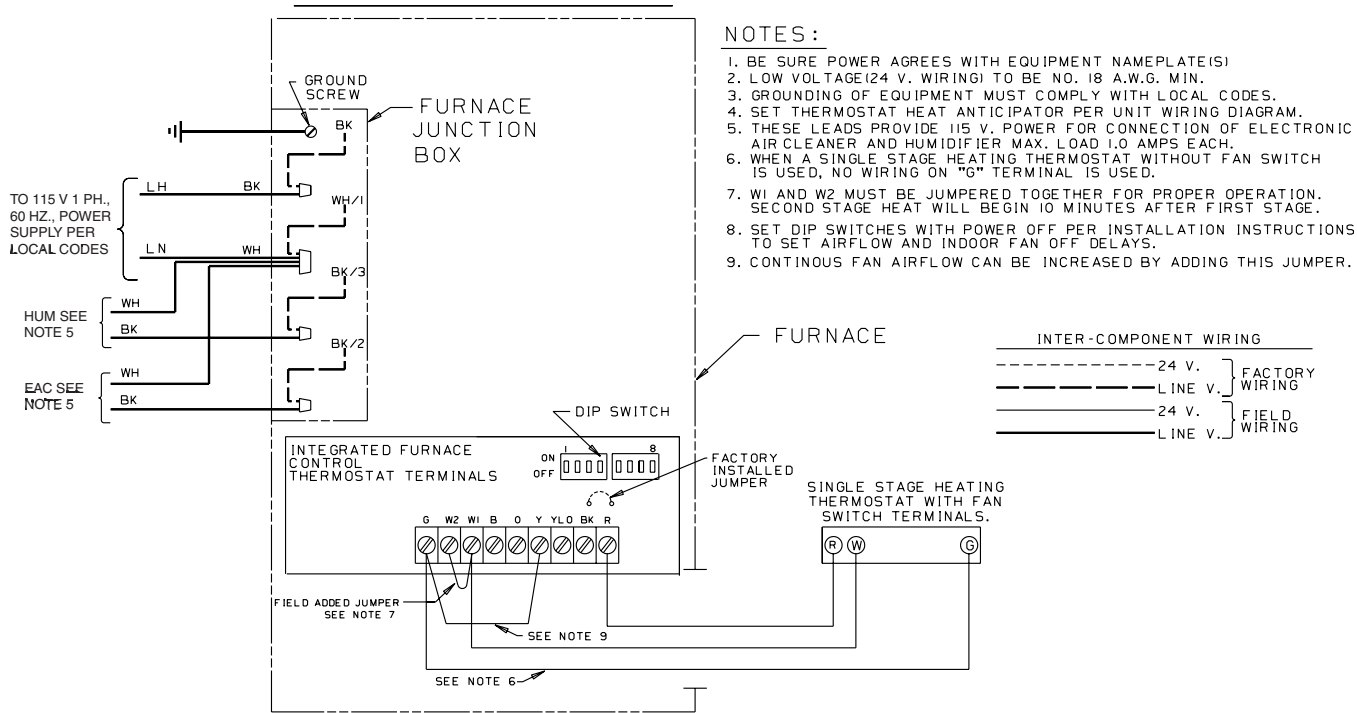

From Dwg. 21B341127 Rev. 0

FIELD WIRING DIAGRAM FOR TWO STAGE HEATING

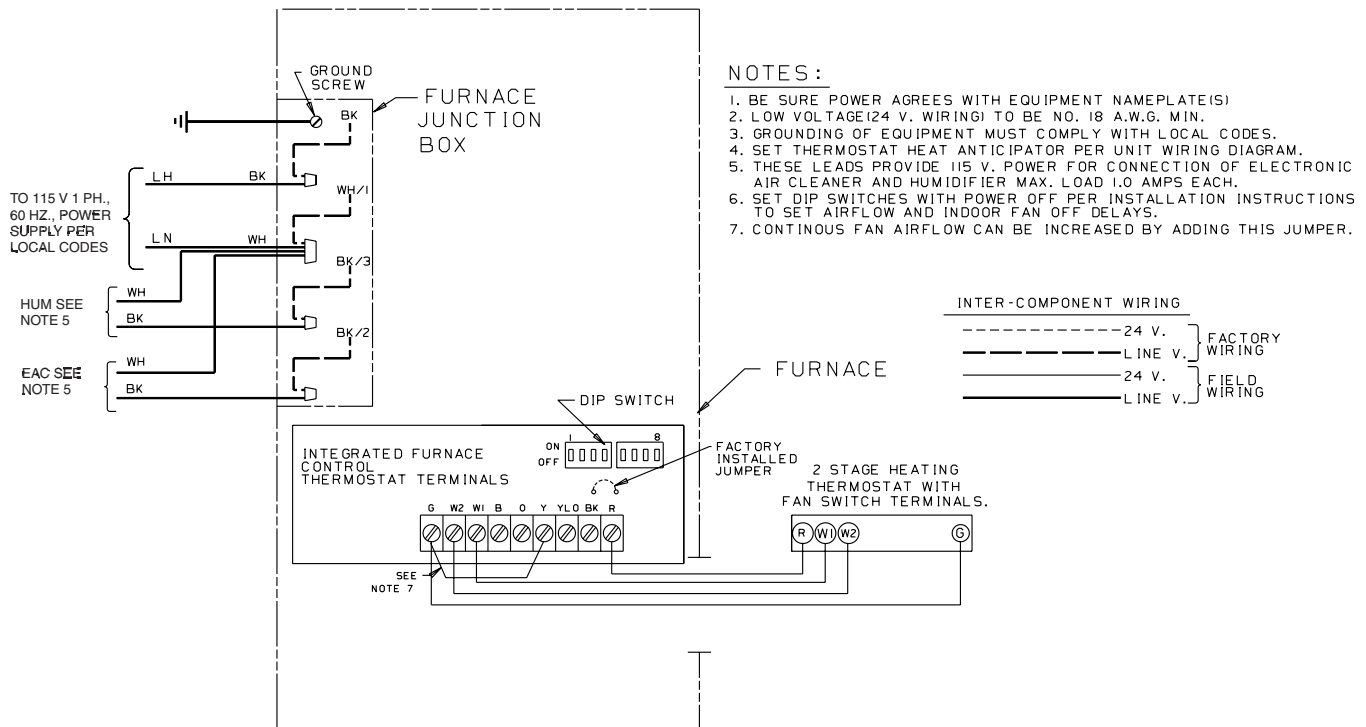

From Dwg. 21B341126 Rev. 0

FIELD WIRING DIAGRAM FOR SINGLE STAGE HEATING WITH SINGLE STAGE COOLING (OUTDOOR SECTION WITHOUT TRANSFORMER)

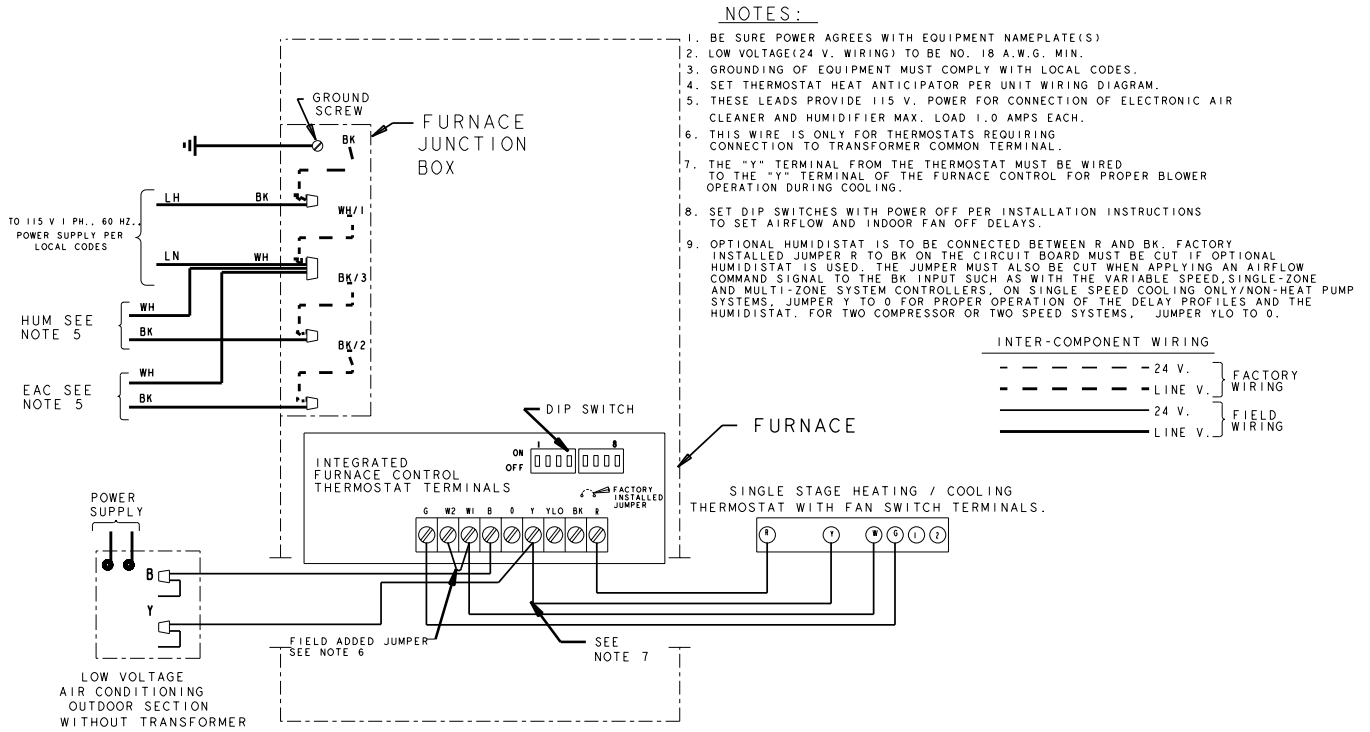

From Dwg. 21B341125 Rev. 1

FIELD WIRING DIAGRAM FOR TWO STAGE HEATING WITH SINGLE STAGE COOLING (OUTDOOR SECTION WITHOUT TRANSFORMER)

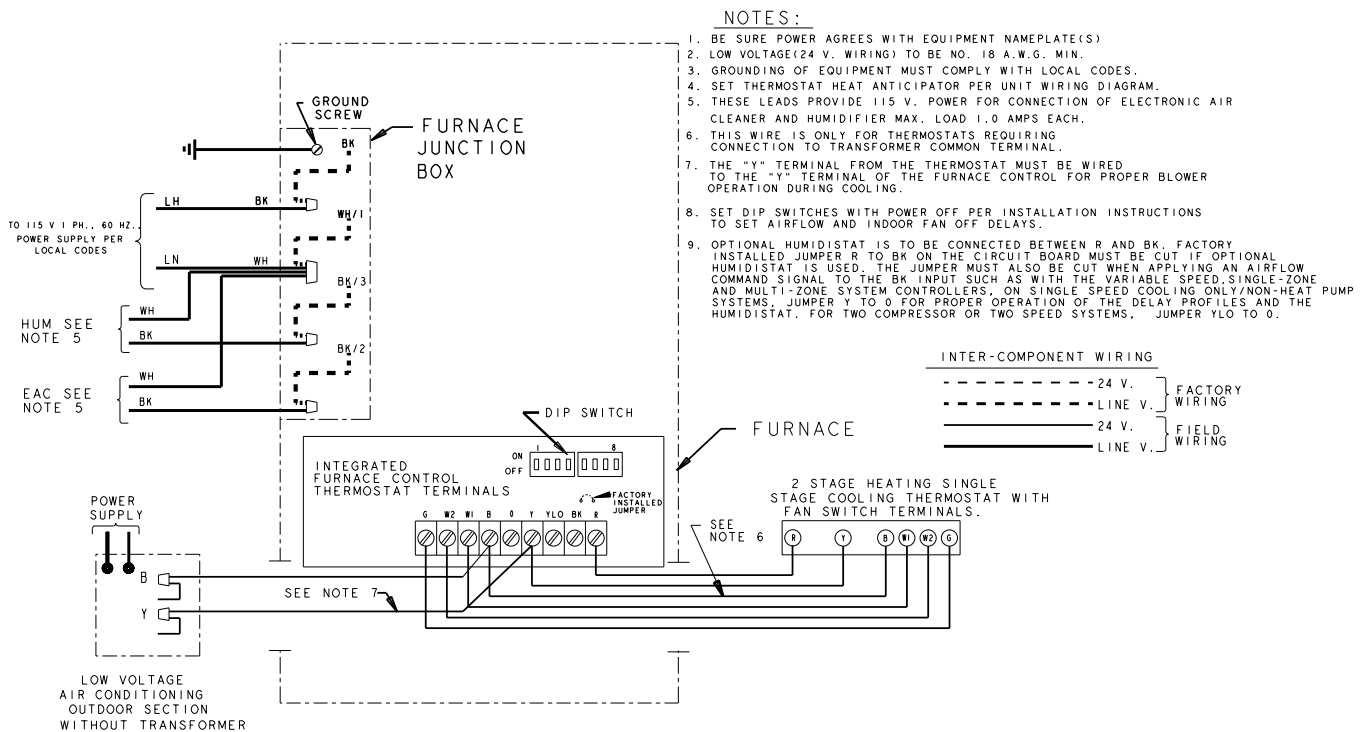

From Dwg. 21B341124 Rev. 1

PRODUCT DATA

**FIELD WIRING DIAGRAM FOR TWO STAGE HEATING WITH TWO STAGE COOLING
(OUTDOOR SECTION WITHOUT TRANSFORMER)**

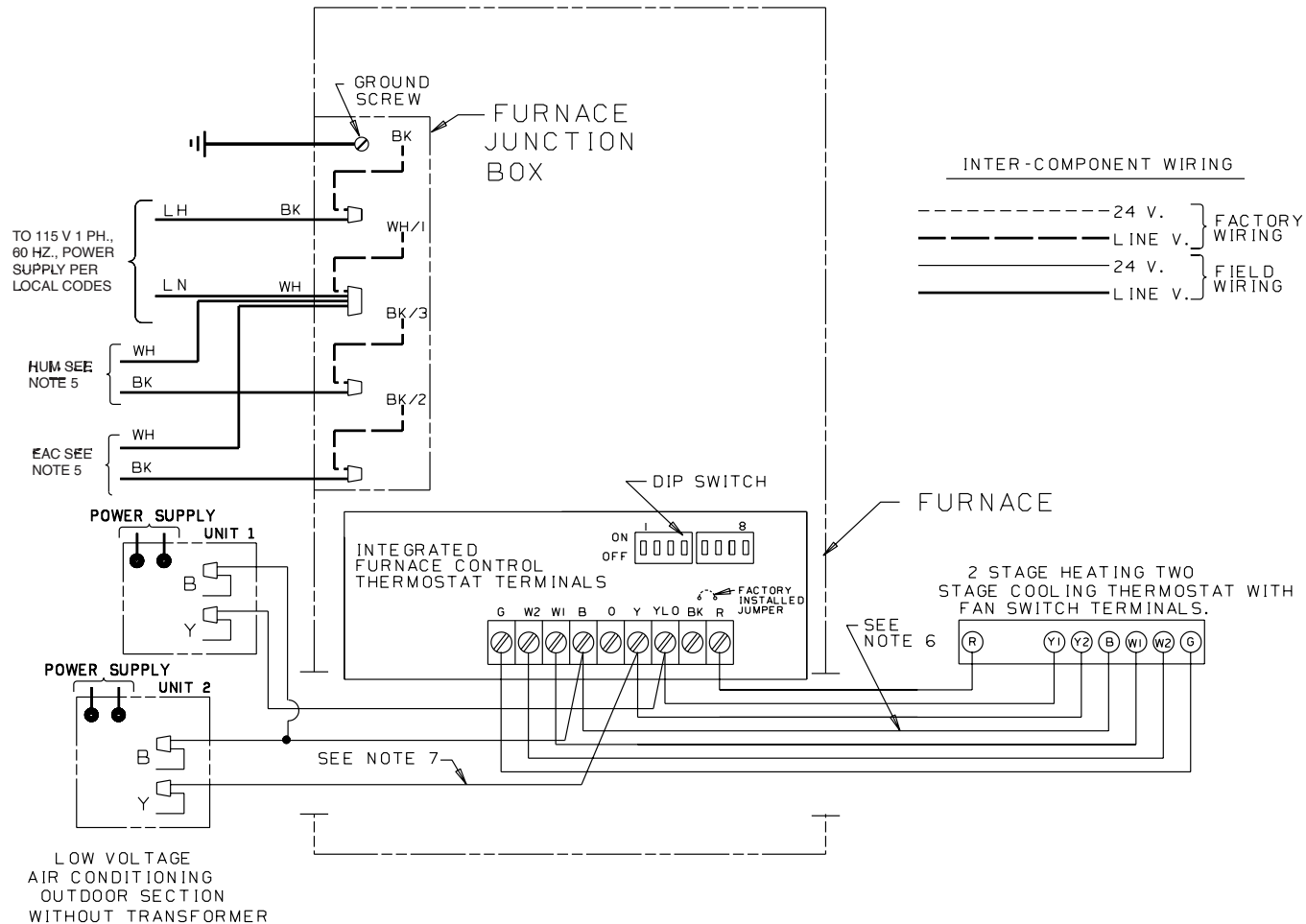

NOTES:

1. BE SURE POWER AGREES WITH EQUIPMENT NAMEPLATE(S)
2. LOW VOLTAGE (24 V. WIRING) TO BE NO. 18 A.W.G. MIN.
3. GROUNDING OF EQUIPMENT MUST COMPLY WITH LOCAL CODES.
4. SET THERMOSTAT HEAT ANTICIPATOR PER UNIT WIRING DIAGRAM.
5. THESE LEADS PROVIDE 115 V. POWER FOR CONNECTION OF ELECTRONIC AIR CLEANER AND HUMIDIFIER MAX. LOAD 1.0 AMPS EACH.
6. THIS WIRE IS ONLY FOR THERMOSTATS REQUIRING CONNECTION TO TRANSFORMER COMMON TERMINAL.
7. THE "Y2" TERMINAL FROM THE THERMOSTAT MUST BE WIRED TO THE "Y" TERMINAL OF THE FURNACE CONTROL FOR PROPER BLOWER OPERATION DURING COOLING.
8. SET DIP SWITCHES WITH POWER OFF PER INSTALLATION INSTRUCTIONS TO SET AIRFLOW AND INDOOR FAN OFF DELAYS.
9. OPTIONAL HUMIDISTAT IS TO BE CONNECTED BETWEEN R AND BK. FACTORY INSTALLED JUMPER R TO BK ON THE CIRCUIT BOARD MUST BE CUT IF OPTIONAL HUMIDISTAT IS USED. THE JUMPER MUST ALSO BE CUT WHEN APPLYING AN AIRFLOW COMMAND SIGNAL TO THE BK INPUT SUCH AS WITH THE VARIABLE SPEED SINGLE-ZONE AND MULTI-ZONE SYSTEM CONTROLLERS. ON SINGLE SPEED COOLING ONLY/NON-HEAT PUMP SYSTEMS, JUMPER Y TO O FOR PROPER OPERATION OF THE DELAY PROFILES AND THE HUMIDISTAT. FOR TWO COMPRESSOR OR TWO SPEED SYSTEMS, JUMPER YLO TO O.

From Dwg. 21B341128 Rev. 0

AUD-9V OUTLINE DRAWING

(ALL DIMENSIONS ARE IN INCHES)

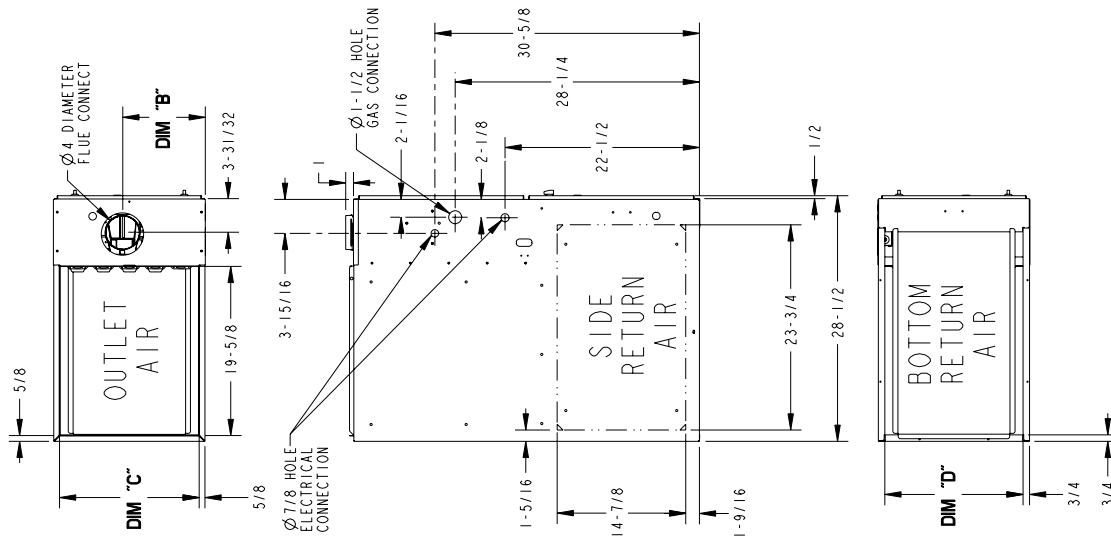

MINIMUM CLEARANCE TO COMBUSTIBLE MATERIALS	
UPFLOW CLOSET	
LEFT SIDE	0 IN.
RIGHT SIDE	+0 IN.
FLUE	+6 IN.
TOP	3 IN. (SEE NOTE 1)
BACK	0 IN.
TOP	1 IN.
HORIZONTAL CLOSET (SEE NOTE 2)	
TOP	+2 IN.
BACK	3 IN.
FLUE	+6 IN.
SIDES	1 IN.
FRONT	18 IN. (SEE NOTE 1)
HORIZONTAL ALCOVE (SEE NOTE 2)	
TOP	+1 IN.
BACK	0 IN.
FLUE	+6 IN.
FRONT	18 IN.
SIDES 0 IN.	

NOTES:

- 1) MINIMUM CLEARANCE TO FRONT ON *UD140R9G AND *UD120C9A IS 6 INCHES.
- 2) MAY BE INSTALLED ON COMBUSTIBLE FLOOR WHEN TYPE B-1 VENT IS USED.

MODEL	A	B	C	D
*UD2B060A9V3V**	17-1/2"	9-5/8"	16-1/4"	16"
*UD2B080A9V3V**				
*UD2B100A9V3V**				
*UD2C080A9V4V**	21"	13-1/16"	19-3/4"	19-1/2"
*UD2C100A9V5V**				
*UD2C080B9V4V**				
*UD2C100B9V5V**				
*UD2D120A9V5V**	24-1/2"	15-5/16"	23-1/4"	23"
*UD2D140A9V5V**				
*UD2D120B9V5V**				

* - First Letter May Be "A" or "T"
 ** - Suffix Letters May Be "K" (0 Through 9)

From Dwg. C341699

PRODUCT DATA

*American
Standard*

HEATING & AIR
CONDITIONING

Since the manufacturer has a policy of continuous product and product data improvement, it reserves the right to change the design and specifications without notice.

Technical Literature - Printed in U.S.A.

American Standard
Heating & Air Conditioning
6200 Troup Highway
Tyler, TX 75707

