

Revision B:

• MSZ-FE09NA - [8] and MSZ-FE12NA - [8] have been added.

Please void OBB542 REVISED EDITION-A.

INDOOR UNIT PARTS CATALOG

No. OBB542
REVISED EDITION-B

Models

MSZ-FE09NA	MSZ-FE09NA	- [8]
MSZ-FE12NA	MSZ-FE12NA	- [8]
MSZ-FE18NA		

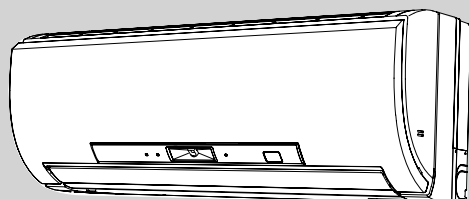

MSZ-FE09NA
MSZ-FE12NA



CONTENTS

1. RoHS PARTS LIST.....	2
-------------------------	---

SERVICE MANUAL (OBH542)

NOTE:
RoHS compliant products have <G> mark on the spec name plate.

Mr. SLIM™

Revision A:

• MSZ-FE18NA has been added.

Revision B:

• MSZ-FE09NA - [8] and MSZ-FE12NA - [8] have been added.

1

RoHS PARTS LIST

MSZ-FE09NA

MSZ-FE12NA

1-1. INDOOR UNIT STRUCTURAL PARTS

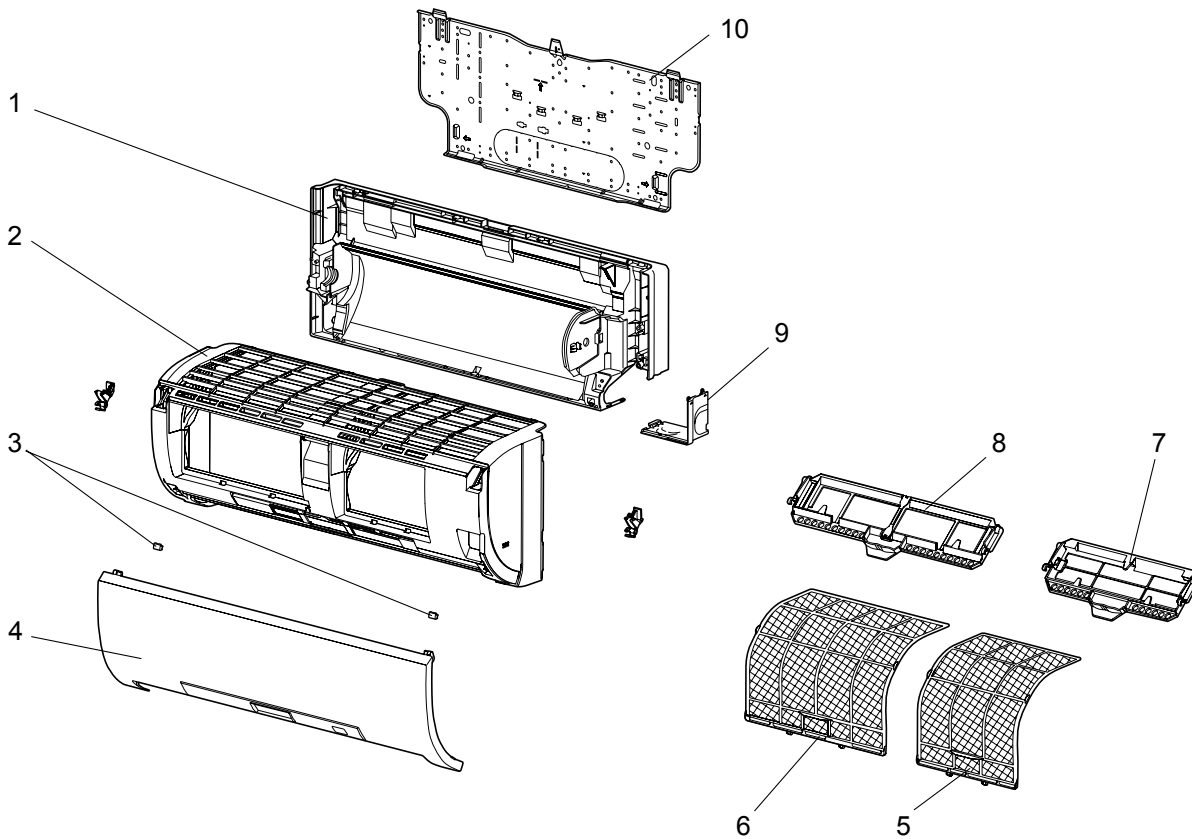

1-2. ACCESSORY AND REMOTE CONTROLLER

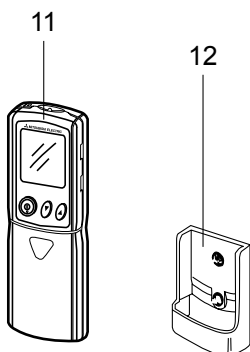

1-1. INDOOR UNIT STRUCTURAL PARTS

No.	RoHS	Part No.	Part name	Symbol in Wiring Diagram	Q'ty/unit				Remarks
					MSZ-FE09 NA	MSZ-FE09 NA - 8	MSZ-FE12 NA	MSZ-FE12 NA - 8	
1	G	E12 C32 234	BOX ASSEMBLY		1	1	1	1	
2	G	E12 C85 000	PANEL ASSEMBLY		1	1	1	1	Including No. 3,4
3	G	E12 913 067	SCREW CAP		2	2	2	2	2 PCS/SET
4	G	E12 C85 010	FRONT PANEL		1	1	1	1	
5	G	E12 C85 100	AIR FILTER (RIGHT)		1	1	1	1	
6	G	E12 C86 100	AIR FILTER (LEFT)		1	1	1	1	
7	G	————	ANTI-ALLERGY ENZYME FILTER		1	1	1	1	MAC-418FT-E
8	G	————	PLATINUM DEODORIZING FILTER		1	1	1	1	MAC-308FT-E
9	G	E12 C32 975	CORNER BOX (RIGHT)		1	1	1	1	
10	G	E12 C32 970	INSTALLATION PLATE		1	1	1	1	

1-2. ACCESSORY AND REMOTE CONTROLLER

11	G	E12 C85 426	REMOTE CONTROLLER		1	1	1	1	KM08C
12	G	E12 527 083	REMOTE CONTROLLER HOLDER		1	1	1	1	

MSZ-FE09NA
MSZ-FE12NA

1-3. INDOOR UNIT ELECTRICAL PARTS AND FUNCTIONAL PARTS

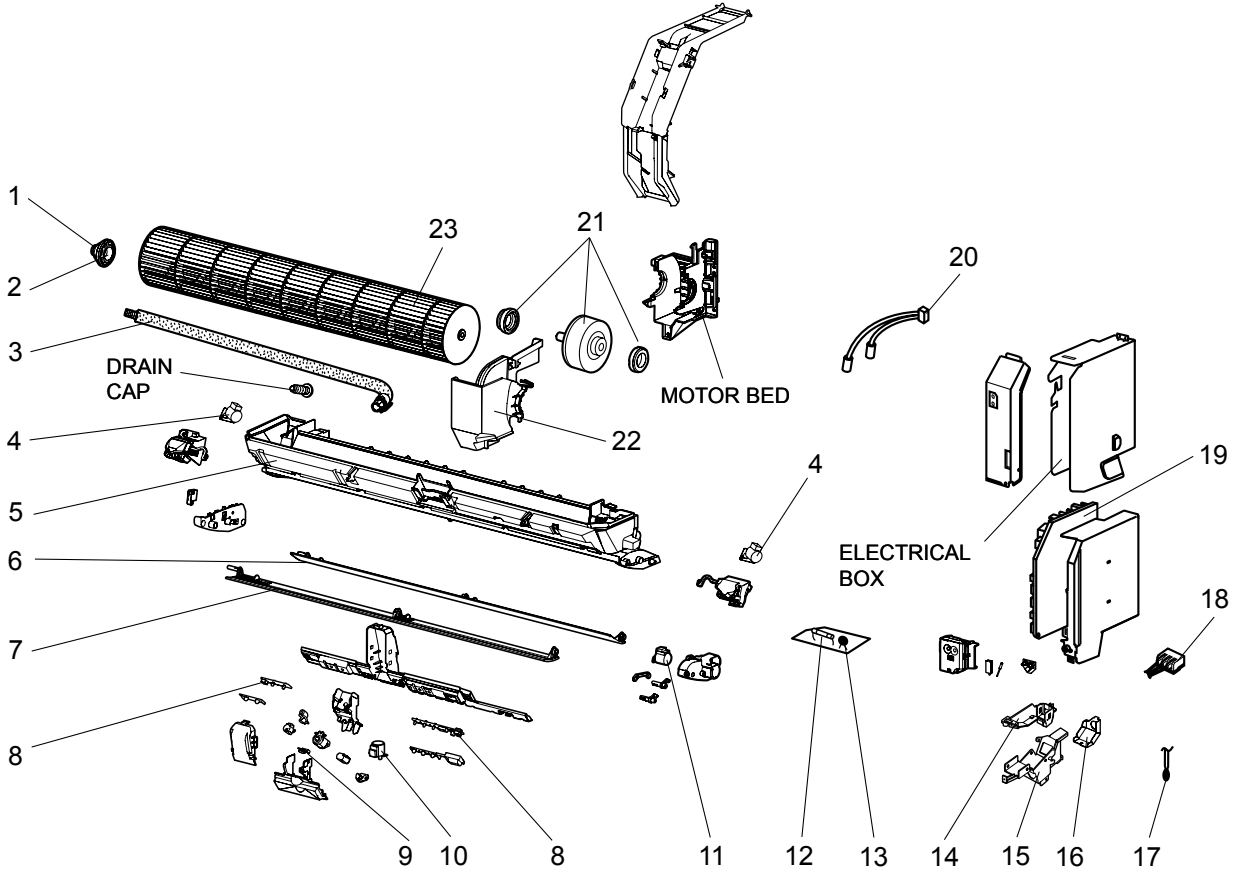

1-3. INDOOR UNIT ELECTRICAL PARTS AND FUNCTIONAL PARTS

No.	RoHS	Part No.	Part name	Symbol in Wiring Diagram	Q'ty/unit				Remarks
					MSZ-FE09 NA	MSZ-FE09 NA - 8	MSZ-FE12 NA	MSZ-FE12 NA - 8	
1	G	E12 751 509	BEARING MOUNT		1	1	1	1	
2	G	E12 001 504	SLEEVE BEARING		1	1	1	1	
3	G	E12 897 702	DRAIN HOSE		1	1	1	1	
4	G	E12 C32 303	VANE MOTOR (VERTICAL)	MV2	2	2	2	2	RIGHT & LEFT
5	G	E12 C85 235	NOZZLE ASSEMBLY		1	1	1	1	
6	G	E12 C32 041	HORIZONTAL VANE (LOWER)		1	1	1	1	
7	G	E12 C32 040	HORIZONTAL VANE (UPPER)		1	1	1	1	
8	G	E12 C85 468	POWER MONITOR RECEIVER P.C. BOARD		1	1	1	1	
9	G	E12 C32 391	i-see Sensor		1	1	1	1	
10	G	E12 A89 303	i-see Sensor MOTOR	MT	1	1	1	1	
11	G	E12 C33 303	VANE MOTOR (HORIZONTAL)	MV1	1	1	1	1	UP & DOWN
12	G	E12 A49 382	FUSE	F11	1	1	1	1	T3.15AL250V
13	G	E12 B75 385	VARISTOR	NR11	1	1	1	1	
14	G	E12 C30 779	TERMINAL BLOCK HOLDER		1	1	1	1	
15	G	E12 C30 780	TERMINAL BLOCK COVER		1	1	1	1	
16	G	E12 C30 979	CONDUIT COVER		1	1	1	1	
17	G	E12 C32 308	ROOM TEMPERATURE THERMISTOR	RT11	1	1	1	1	
18	G	E12 913 375	TERMINAL BLOCK	TB	1	1	1	1	
19	G	E12 F26 452	ELECTRONIC CONTROL P.C. BOARD ※1		1				
	G	E12 G39 452	ELECTRONIC CONTROL P.C. BOARD ※1			1			
	G	E12 F27 452	ELECTRONIC CONTROL P.C. BOARD ※1				1		
	G	E12 G40 452	ELECTRONIC CONTROL P.C. BOARD ※1					1	
20	G	E12 C32 307	INDOOR COIL THERMISTOR	RT12,RT13	1	1	1	1	
21	G	E12 F26 300	INDOOR FAN MOTOR ※2	MF	1	1	1	1	RC0J30-□□
22	G	E12 C32 333	MOTOR BAND		1	1	1	1	
23	G	E12 C32 302	LINE FLOW FAN		1	1	1	1	

※1 Including SW P.C. BOARD

※2 Including FAN MOTOR RUBBER MOUNT (2 PCS/SET)

MSZ-FE09NA
MSZ-FE12NA

1-4. INDOOR UNIT HEAT EXCHANGER

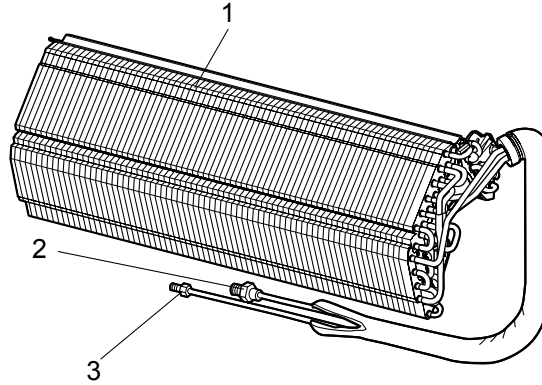

No.	RoHS	Part No.	Part name	Symbol in Wiring Diagram	Q'ty/unit				Remarks
					MSZ-FE09NA	MSZ-FE09NA - 8	MSZ-FE12NA	MSZ-FE12NA - 8	
1	G	E12 C85 620	INDOOR HEAT EXCHANGER		1	1	1	1	
2	G	E12 815 666	UNION (GAS) (ø9.52)		1	1	1	1	ø3/8
3	G	E12 C32 667	UNION (LIQUID) (ø6.35)		1	1	1	1	ø1/4

MSZ-FE18NA
1-5. INDOOR UNIT STRUCTURAL PARTS

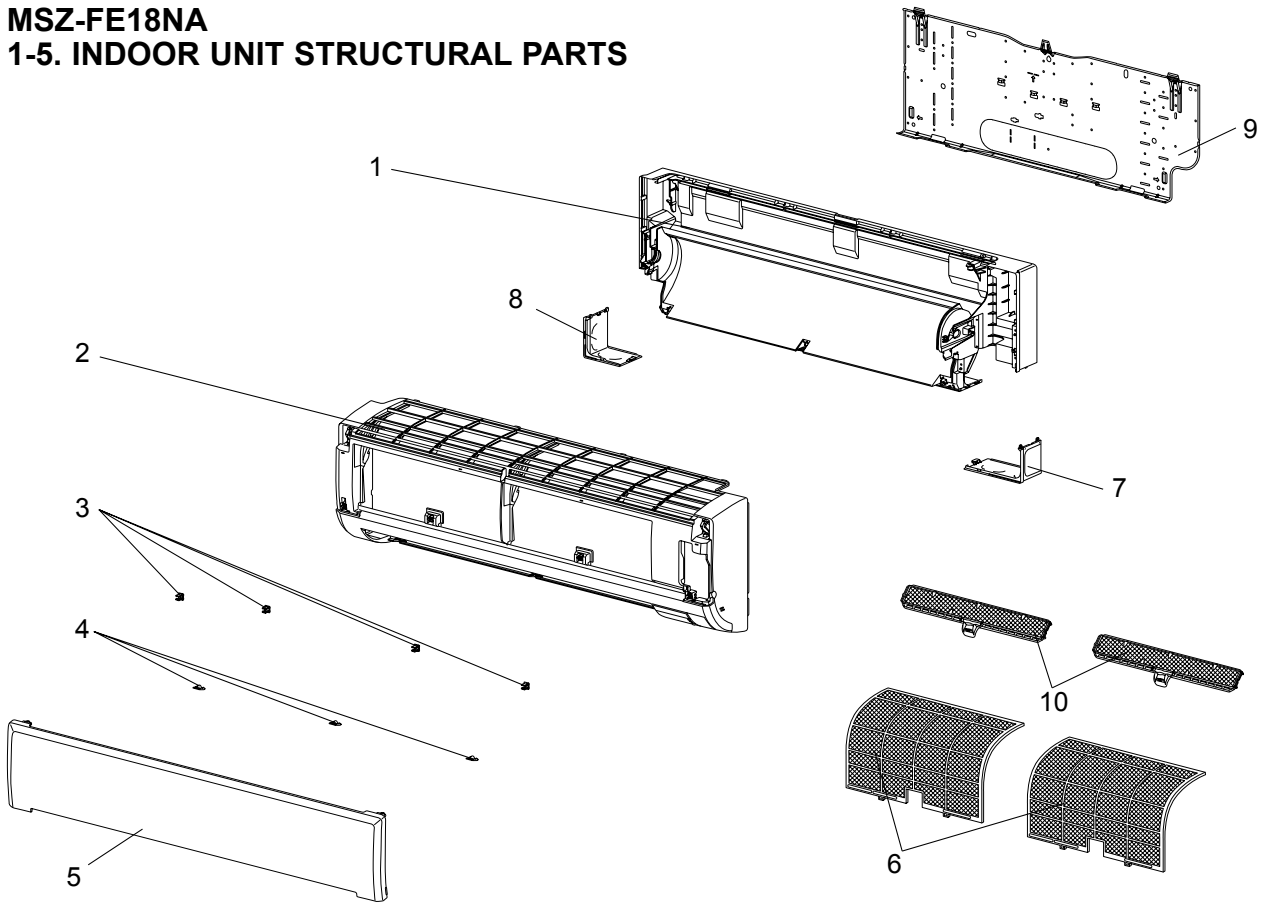

No.	RoHS	Part No.	Part name	Symbol in Wiring Diagram	Q'ty/unit	Remarks
					MSZ-FE18NA	
1	G	E12 F28 234	BOX ASSEMBLY		1	
2	G	E12 F76 000	PANEL ASSEMBLY		1	Including No. 3,4,5
3	G	E12 408 142	CATCH		4	4 PCS/SET
4	G	E12 F28 067	SCREW CAP		3	3 PCS/SET
5	G	E12 F28 010	FRONT PANEL		1	
6	G	E12 F28 100	NANO PLATINUM FILTER		2	1 PC/SET
7	G	E12 F28 975	CORNER BOX (RIGHT)		1	
8	G	E12 F28 976	CORNER BOX (LEFT)		1	
9	G	E12 F28 970	INSTALLATION PLATE		1	
10	G	-	AIR CLEANING FILTER (ELECTROSTATIC ANTI-ALLERGY ENZYME FILTER)		2	MAC-2310FT-E 2 PCS/SET

1-6. ACCESSORY AND REMOTE CONTROLLER

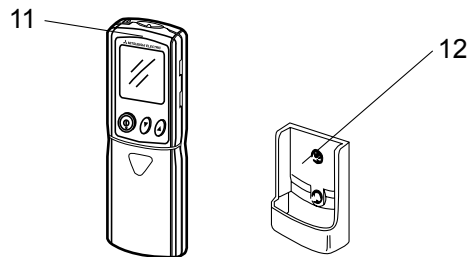

11	G	E12 C26 426	REMOTE CONTROLLER		1	KM07K
12	G	E12 527 083	REMOTE CONTROLLER HOLDER		1	

MSZ-FE18NA

1-7. INDOOR UNIT ELECTRICAL PARTS AND FUNCTIONAL PARTS

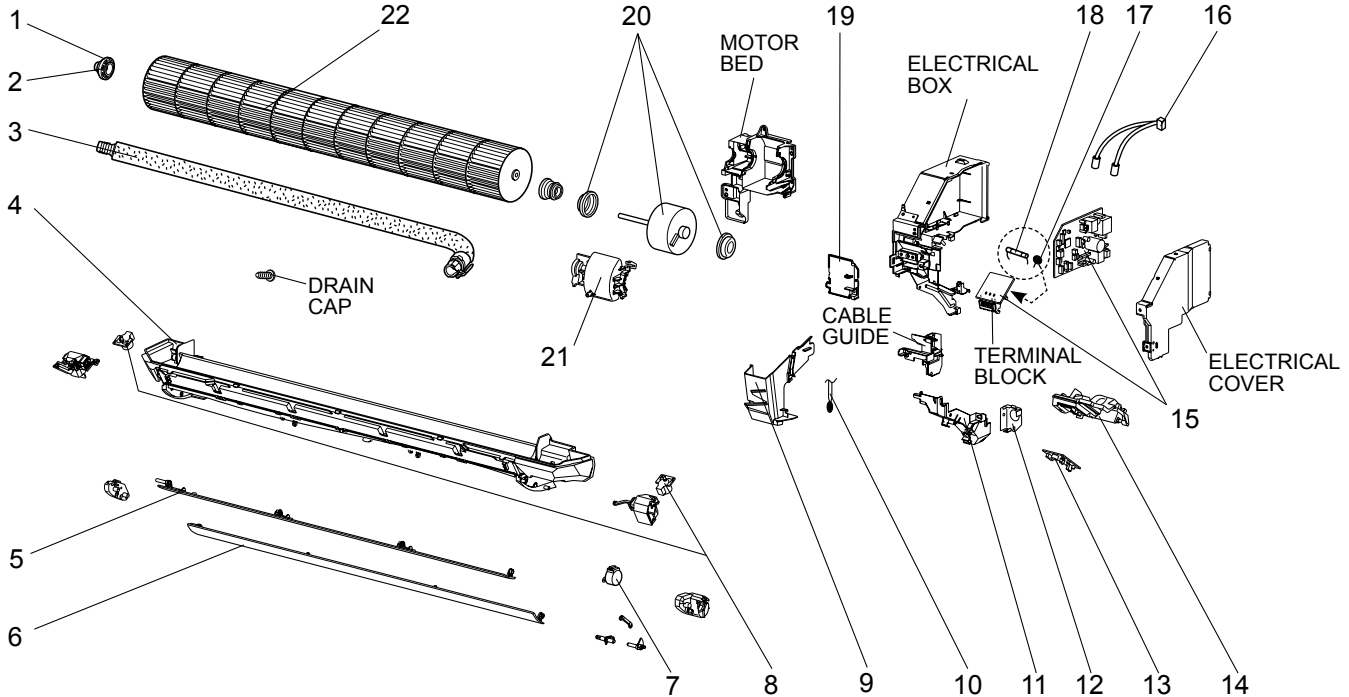

No.	RoHS	Part No.	Part name	Symbol in Wiring Diagram	Q'ty/unit		Remarks
						MSZ-FE18NA	
1	G	E12 751 509	BEARING MOUNT			1	
2	G	E12 001 504	SLEEVE BEARING			1	
3	G	E12 408 702	DRAIN HOSE			1	
4	G	E12 F76 235	NOZZLE ASSEMBLY			1	
5	G	E12 F76 040	VANE (UPPER)			1	
6	G	E12 F76 041	VANE (LOWER)			1	
7	G	E12 C33 303	VANE MOTOR (HORIZONTAL)	MV1		1	UP & DOWN
8	G	E12 C32 303	VANE MOTOR (VERTICAL)	MV2		2	RIGHT & LEFT
9	G	E12 F28 541	WATER CUT			1	
10	G	E12 C32 308	ROOM TEMPERATURE THERMISTOR	RT11		1	
11	G	E12 F76 979	CONDUIT COVER			1	
12	G	E12 F76 978	CONDUIT PLATE			1	
13	G	E12 F28 468	POWER MONITOR RECEIVER SW P.C. BOARD			1	
14	G	E12 F28 095	POWER MONITOR RECEIVER HOLDER			1	
15	G	E12 G33 452	ELECTRONIC CONTROL P.C. BOARD ※1			1	
16	G	E12 F28 307	INDOOR COIL THERMISTOR	RT12,RT13		1	
17	G	E12 B75 385	VARISTOR	NR11		1	
18	G	E12 A49 382	FUSE	F11		1	T3.15AL250V
19	G	E12 F76 784	V.A. CLAMP			1	
20	G	E12 F28 300	INDOOR FAN MOTOR ※2	MF		1	RC0J56-□□
21	G	E12 F28 333	MOTOR BAND			1	
22	G	E12 F28 302	LINE FLOW FAN			1	

※1 Including TERMINAL BLOCK with TERMINAL P.C. BOARD

※2 Including FAN MOTOR RUBBER MOUNT (2 PCS/SET)

MSZ-FE18NA

1-8. INDOOR UNIT HEAT EXCHANGER

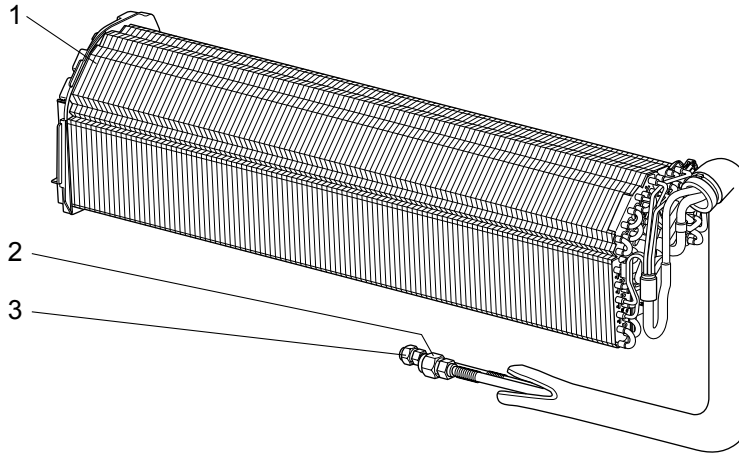

No.	RoHS	Part No.	Part name	Symbol in Wiring Diagram	Q'ty/unit	Remarks
					MSZ-FE18NA	
1	G	E12 F29 620	INDOOR HEAT EXCHANGER		1	
2	G	E12 527 666	UNION (GAS)		1	ø5/8
3	G	E12 815 666	UNION (LIQUID)		1	ø3/8



© Copyright 2009 MITSUBISHI ELECTRIC CO., LTD
Distributed in Apr. 2011. No. OBB542 REVISED EDITION-B
Distributed in Sep. 2010 No. OBB542 REVISED EDITION-A 5
Distributed in Jul. 2009 No. OBB542 5
Made in Japan

New publication, effective Apr. 2011
Specifications subject to change without notice.