

Ref. No.	Description	Material		Qty
		600	600A	
1	Body	ASTM A351 Gr. CF8M		1
2	Ball	316SS		1
3	End Cap	ASTM A351 Gr. CF8M		1
4	Seat	RTFE (PTFE+15% G.F.)		2
5	Body Seal	PTFE	Grafoil+316SS	1
6	Stem	316SS		1
7	Stem Packing	PTFE	Grafoil	1 Set
7A	Stem Bushing	PTFE		1
7B	Bearing	PTFE		1
8	Handle	FCD45		1
9	Snap Ring	304SS		2
9A	Stop Plate	304SS		1
10	Thrust Washer	PTFE	PTFE+Grafoil	1
11	Gland	304SS		1
13	Gland Bolt	304SS		2
17	Body Stud	ASTM A193 Gr. B8		4-12
18	Body Nut	ASTM A194 Gr. 8		4-12

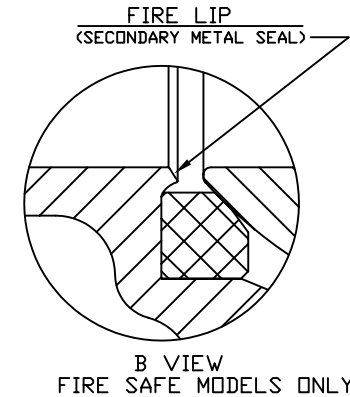
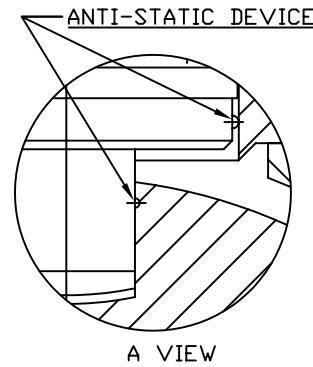

Size	ØB	ØC	ØD	E	ØG	L	H	S	ØK	ØM	T1	T2	n	ØN
1/2	2.38	1.38	0.50	5.59	3.50	4.25	3.10	0.433	1.65	1/4-20	0.06	0.44	4	0.62
3/4	2.75	1.69	0.75	5.59	3.88	4.62	3.61	0.433	1.65	1/4-20	0.06	0.44	4	0.62
1	3.12	2.00	1.00	5.59	4.25	5.00	3.04	0.551	1.97	1/4-20	0.06	0.44	4	0.62
1-1/2	3.88	2.88	1.50	7.87	5.00	6.50	4.36	0.669	2.76	5/16-18	0.06	0.56	4	0.62
2	4.75	3.62	2.00	7.87	6.00	7.00	4.66	0.669	2.76	5/16-18	0.06	0.62	4	0.75
2-1/2	5.50	4.12	2.50	7.87	7.00	7.50	5.57	0.669	2.76	5/16-18	0.06	0.69	4	0.75
3	6.00	5.00	3.00	12.93	7.50	8.00	6.64	0.866	4.02	3/8-16	0.06	0.75	4	0.75
4	7.50	6.19	4.00	12.93	9.00	9.00	7.55	0.866	4.02	3/8-16	0.06	0.94	8	0.87
6	9.50	8.50	6.00	29.62	11.00	15.50	10.89	1.063	4.92	1/2-13	0.06	1.00	8	0.87
8	11.75	10.62	7.87	39.37	13.50	17.99	11.81	0.866	5.51	5/8-11	0.06	1.12	8	0.87
10	14.25	12.76	9.84	39.37	15.98	21.00	13.78	1.063	6.50	3/4-10	0.06	1.20	12	1.00

		4120 NE Columbia Blvd Portland, OR 97211 Phone (503) 287-8383 Fax (503) 281-9677	
		TITLE/DESCRIPTION: Fig 600/600A, 2PC, 150# FLANGED <RF>, STAINLESS STEEL x STAINLESS STEEL, FUL PORT (FIRE SAFE OPTION)	
DATE: 8-3-2005	BY:	UNITS: INCHES	
SCALE: NONE	APP'D:	PAGE(S): 1	
MODEL: 600 & 600A			
DWG NO: FNW600/600A			
NOTES:			
FILE: 600_050-10.dwg	WT:	LOC: PORTLAND	
PAGE SIZE: 8.5 x 11L	REV: 0	R'DATE:	
THIS DRAWING CONTAINS CONFIDENTIAL AND PROPRIETARY INFORMATION OF FNW VALVE AND IS SUBMITTED TO YOU FOR THE LIMITED PURPOSE OF PROVIDING YOU INFORMATION ON PRODUCTS AND SYSTEMS PURCHASED FROM FNW VALVE. BY RECEIVING THIS DOCUMENT, YOU AGREE NOT TO DISCLOSE SUCH INFORMATION TO OTHERS EXCEPT BY WRITTEN PERMISSION OF FNW VALVE.			