

DOMESTIC

NON-DOMESTIC

SUBMITTAL: C110 FLANGE JOINT CLASS 125 PRODUCT

(Current revisions for the noted Standards apply)

- SIZES:** 2" - 64" (Contact Tyler Union for 54" - 64" flange fitting information)
- STANDARDS:** ANSI/AWWA C110/A21.10, NFPA 13/24, ASME B16.1, 3" - 12" UL listed and FM approved
- MATERIAL:** Cast of ASTM A536 qualified ductile iron. Date code is cast on and required for traceability.
- PRESSURE RATING:** *Flanged fittings *2" - 48" rated at 250 psi. 54" - 64" rated at 150psi.
*Note: With rubber annular ring flange gasket, 2" - 24" flanged fittings can be rated at 350 psi.
- DEFLECTION:** Deflection is "not" recommended for flange joint due to the rigidity of the joint.
- NSF-61 & NSF372:** Meets all requirements including Annex G, Tyler Union's Underwriters Laboratory listing MH16439.
- COATING:** Asphaltic or Primer per ANSI/AWWA C104/A21.4, Standard primer is Tnemec Pota Pox N140-1211. Contact Tyler Union for additional coating options.
- CEMENT LINING:** Per ANSI/AWWA C104/A21.4, with double cement lining available upon request.
- EPOXY COATING:** Fusion bonded epoxy per ANSI/AWWA C116/A21.16. Additional coatings available upon request.
- BARE FITTINGS:** Available upon request.
- FLANGES:** ANSI Class 125 per ASME B16.1 and ANSI/AWWA C111/A21.11. Bolt holes shall straddle the center line
- NOTE: Class 125 ASME B16.1 are not compatible with Class 250 Flanges**
- NOTE: Class 250 ASME B16.1 fittings are available upon request.**
- FASTNERS:** High strength low alloy weathering steel per ANSI/AWWA C111/A21.11 and ASTM A242
- INSTALLATION:** Install per AWWA C600/C651 using pipe conforming to ANSI/AWWA C151/A21.51.

FLANGE DETAILS IN INCHES

BOLTS

Size Inches	Diameter DI Pipe	Flange O.D.	B.C. Diameter	Flange Thickness T	Bolt Hole Diameter	Size	Qty
2	2.51	6.00	4.75	0.62	0.750	5/8 x 2-1/4	4
3	3.96	7.50	6.00	0.75	0.750	5/8 x 2-1/4	4
4	4.80	9.00	7.50	0.94	0.750	5/8 x 3	8
6	6.90	11.00	9.50	1.00	0.875	3/4 x 3-1/2	8
8	9.05	13.50	11.75	1.12	0.875	3/4 x 3-1/2	8
10	11.10	16.00	14.25	1.19	1.000	7/8 x 4	12
12	13.20	19.00	17.00	1.25	1.000	7/8 x 4	12
14	15.30	21.00	18.75	1.38	1.125	1 x 4-1/2	12
16	17.40	23.50	21.25	1.44	1.125	1 x 4-1/2	16
18	19.50	25.00	22.75	1.56	1.250	1-1/8 x 5	16
20	21.60	27.50	25.00	1.69	1.250	1-1/8 x 5	20
24	25.80	32.00	29.50	1.88	1.375	1-1/4 x 5-1/2	20
30	32.00	38.75	36.00	2.12	1.375	1-1/4 x 5-1/2	28
36	38.30	46.00	42.75	2.38	1.625	1-1/2 x 7	32
42	44.50	53.00	49.50	2.62	1.625	1-1/2 x 7-1/2	36
48	50.80	59.50	56.00	2.75	1.625	1-1/2 x 8	44
54						Available on Request	
60						Available on Request	
64						Available on Request	

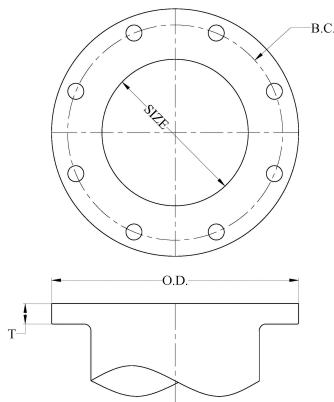

C110 DUCTILE IRON FULL BODY FITTINGS

SAMPLE SPECIFICATIONS

(Current ANSI/AWWA revisions apply)

Flanged fittings, 2” through 64”, shall be manufactured of Ductile Iron in accordance with all applicable terms and provisions of standards ANSI/AWWA C110/A21.10. Flange surfaces shall be faced and drilled in accordance with ANSI Class 125, B16.1. All Ductile Iron flanged fittings shall be rated for water pressure of 250 psi. Flanged ductile iron fittings in 24” (610 mm) and smaller sizes may be rated for 350 psi (2,413 kPa) with the use of special gaskets .

NOTE: Fittings are available prime coated, bare or epoxy coated. All coated fittings meet requirements of NSF-61, NSF-372 and Annex G. Interiors of fittings shall be lined and seal coated in accordance with ANSI/AWWA C104/A21.4. Installation of fittings shall be per AWWA C110.

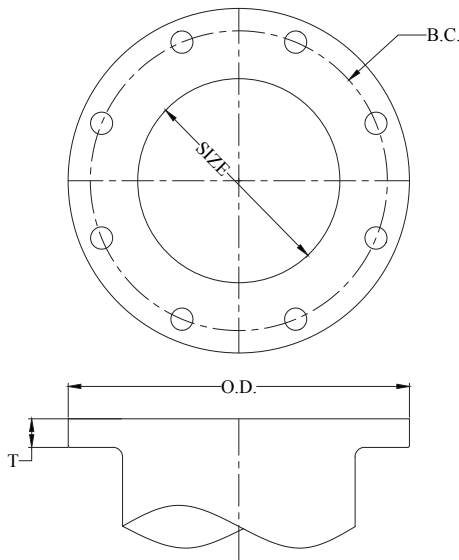

ANSI/AWWA C110 Class 125 Flange Fittings

FLANGE DETAILS						
Nominal Pipe Size Inch	Flange O.D.	B.C. Diameter	Flange Thickness T	Bolt Hole Diameter	Number of Bolts	Bolt Dia. and Lengths
2	6.00	4.75	0.62	0.750	4	5/8 x 2 1/4
3	7.50	6.00	0.75	0.750	4	5/8 x 2 1/2
4	9.00	7.50	0.94	0.750	8	5/8 x 3
6	11.00	9.50	1.00	0.880	8	3/4 x 3 1/2
8	13.50	11.75	1.12	0.880	8	3/4 x 3 1/2
10	16.00	14.25	1.19	1.000	12	7/8 x 4
12	19.00	17.00	1.25	1.000	12	7/8 x 4
14	21.00	18.75	1.38	1.130	12	1 x 4 1/2
16	23.50	21.25	1.44	1.130	16	1 x 4 1/2
18	25.00	22.75	1.56	1.250	16	1 1/8 x 5
20	27.50	25.00	1.69	1.250	20	1 1/8 x 5
24	32.00	29.50	1.88	1.375	20	1 1/4 x 5 1/2
30	38.75	36.00	2.12	1.375	28	1 1/4 x 6 1/2
36	46.00	42.75	2.38	1.625	32	1 1/2 x 7
42	53.00	49.50	2.62	1.625	36	1 1/2 x 7 1/2
48	59.50	56.00	2.75	1.625	44	1 1/2 x 8
54	66.25	62.75	3.00	2.00	44	1 3/4 x 8 1/2
60	73.00	69.25	3.12	2.00	52	1 3/4 x 9
64	80.00	76.00	3.38	2.00	52	1 3/4 x 9

Contact Tyler Union for 54”–64” flange fitting information.

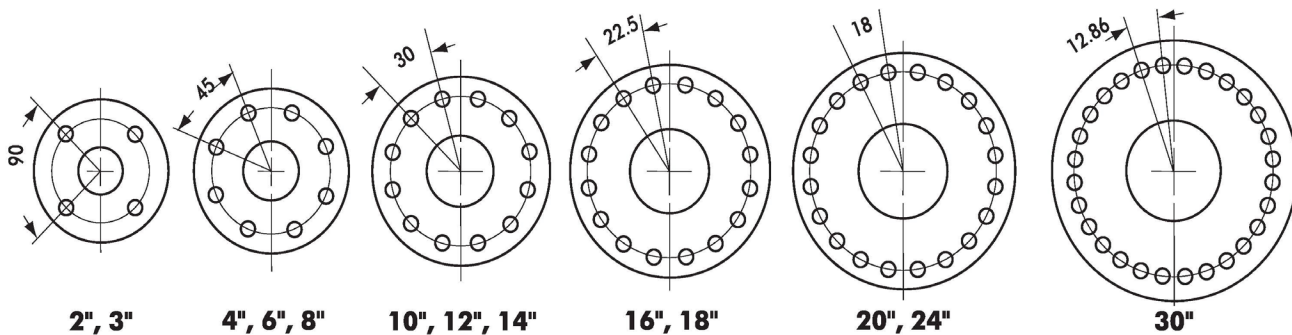

NOTE: Drilling templates are in multiples of four so that fittings may be made to face in any quarter. Bolt holes shall straddle the center line.

C110 DUCTILE IRON FULL BODY FITTINGS

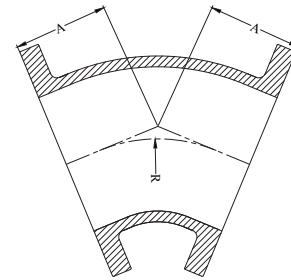
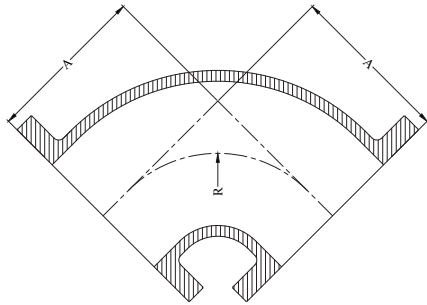

90° (1/4) BENDS				
Size	R	A	Domestic	Import
			Weight	Weight
2	3.00	4.50	14	—
3	4.00	5.50	26	25
4	4.50	6.50	44	45
6	6.00	8.00	67	65
8	7.00	9.00	115	105
10	9.00	11.00	159	165
12	10.00	12.00	244	235
14	11.50	14.00	341	290
16	12.50	15.00	455	370
18	14.00	16.50	527	450
20	15.50	18.00	878	580
24	18.50	22.00	1085	900
30	21.50	25.00	1427	1430
36	24.50	28.00	2135	2135
42	27.50	31.00	3055	3055
48	30.50	34.00	4095	4095

45° (1/8) BENDS				
Size	R	A	Domestic	Import
			Weight	Weight
2	—	—	—	—
3	3.62	3.00	20	20
4	4.81	4.00	36	40
6	7.25	5.00	57	55
8	8.44	5.50	105	90
10	10.88	6.50	127	130
12	13.25	7.50	149	195
14	12.06	7.50	260	220
16	13.25	8.00	322	280
18	14.50	8.50	371	325
20	16.88	9.50	485	430
24	18.12	11.00	742	630
30	27.75	15.00	1355	1120
36	35.00	18.00	1755	1755
42	42.25	21.00	2600	2600
48	49.50	24.00	3580	3580

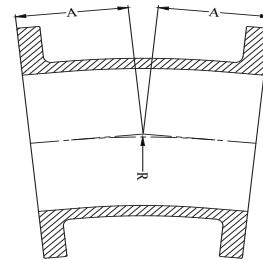
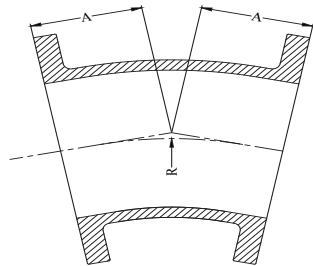

22½° (1/16) BENDS				
Size	R	A	Domestic	Import
			Weight	Weight
2	—	—	—	—
3	7.56	3.00	22	20
4	10.06	4.00	35	40
6	15.06	5.00	64	55
8	17.62	5.50	90	90
10	22.62	6.50	130	135
12	27.67	7.50	199	205
14	25.12	7.50	281	225
16	27.62	8.00	315	285
18	30.19	8.50	402	335
20	35.19	9.50	543	435
24	37.69	11.00	528	640
30	57.81	15.00	1385	1135
36	72.88	18.00	1790	1790
42	88.00	21.00	2665	2663
48	103.06	24.00	3665	3665

11¼° (1/32) BENDS				
Size	R	A	Domestic	Import
			Weight	Weight
2	—	—	—	—
3	15.25	3.00	20	20
4	20.31	4.00	40	40
6	30.50	5.00	56	55
8	35.50	5.50	90	90
10	45.69	6.50	136	135
12	55.81	7.50	213	205
14	50.75	7.50	261	225
16	55.81	8.00	315	285
18	60.94	8.50	385	335
20	71.06	9.50	505	435
24	76.12	11.00	760	645
30	116.75	15.00	1395	1150
36	147.25	18.00	1805	1805
42	177.69	21.00	2680	2680
48	208.12	24.00	3695	3695