



PACKAGE AIR CONDITIONERS

FORM NO. S11-934 REV. 3
Supersedes Form No. S11-934 Rev. 2

Featuring Earth-Friendly R-410A Refrigerant



RSNL- 13-SEER SERIES NOMINAL SIZES 2-5 TONS [7.0-17.6 kW]

RSPL- 14-SEER SERIES NOMINAL SIZES 2-5 TONS [7.0-17.6 kW]



*"Proper sizing and installation of equipment is critical to achieve optimal performance.
Ask your Contractor for details or visit www.energystar.gov <<http://www.energystar.gov/>>."*



Unit Features & Benefits	3-4
Model Identification Options.....	5-6
General Data	
RSNL- Series	7-9
RSPL- Series	10-12
General Data Notes	13
Performance Data	
RSNL- Series	14-16
RSPL- Series	17-19
Airflow Performance	
RSNL- Series	20-22
RSPL- Series	23-26
Electrical Data	
RSNL- Series.....	27
RSPL- Series.....	28
Electric Heater Kits	29-30
Dimensional Data	31-32
Typical Installations	33
Accessories	34-43
Typical Wiring.....	44-49
Limited Warranty	52



These quality features are included in the Rheem Package Air Conditioner

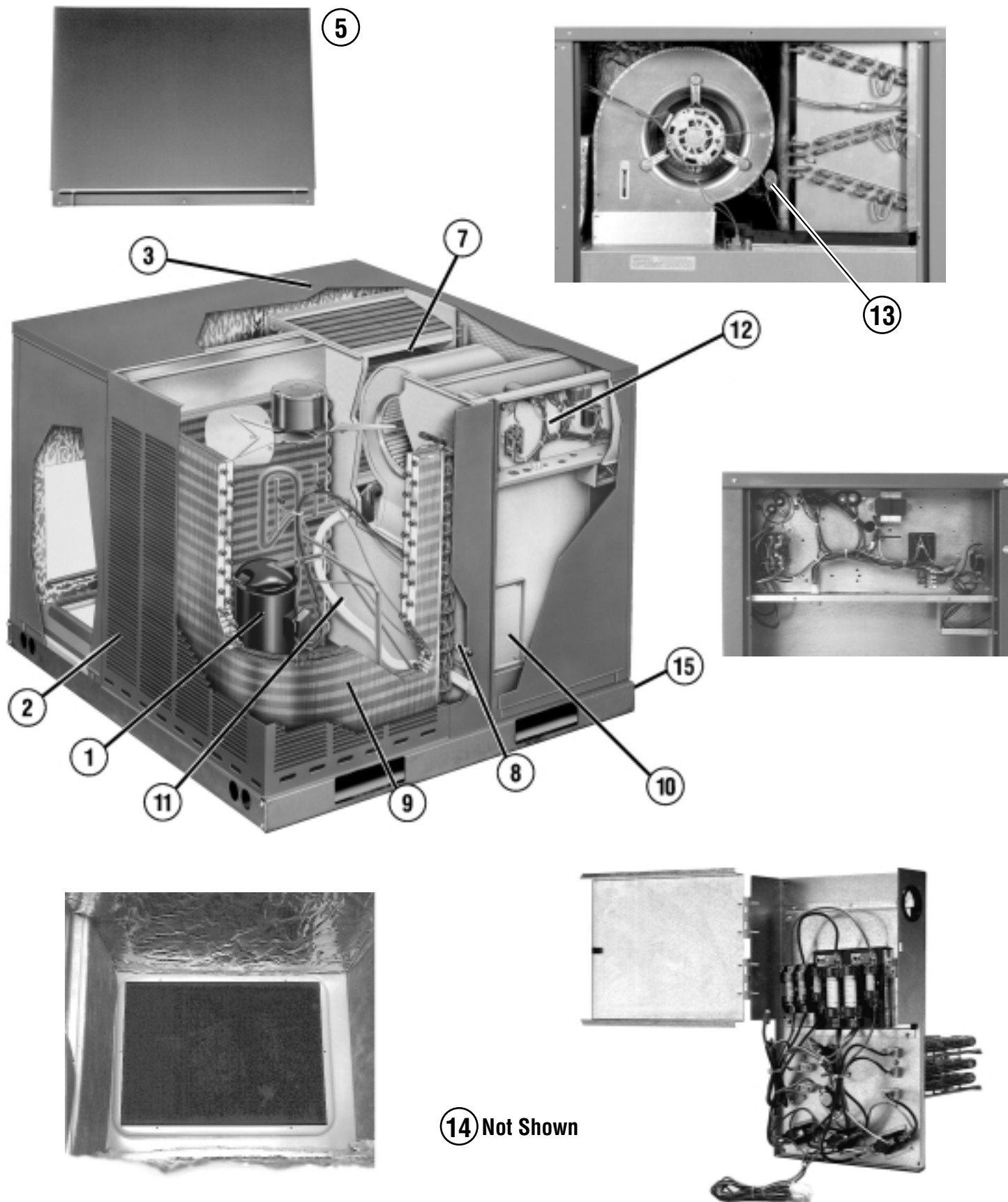



Features Below Correspond to Photos on Page 3

1. All models feature Scroll® compressors for maximum efficiency and quiet operation. The 5-Ton RSPL model features Scroll UltraTech™ 2-Stage compressors with Comfort Alert™ diagnostics (see below), high/low pressure switches, and hard start kits.
2. Louvered condenser compartment for protecting the coil against yard hazards and/or weather extremes.
3. One-piece top with a drip lip to help keep water off of the unit sides.
4. Supply and return air openings feature a one-inch tall flange to prevent water migration into the ductwork.
5. Access panels have “weep holes” and channels to further help manage water run-off.
6. Side and down discharge options available on all models.
7. Easily accessible blower section complete with slide-out blower.
8. Refrigerant connections are conveniently located for easy service diagnostics.
9. Condenser and evaporator coils feature enhanced fins for better heat transfer and rifled copper tubing for greater efficiency.
10. Supplemental electric heat strips up to 15 kW are available (field or factory installed) for periods of extreme cold temperatures. Single point wiring simplifies installation.
11. All units feature an internal trap on the condensate line eliminating the need for installing an on-site external trap.
12. Easily accessible control box.
13. Thermal expansion valve standard on all models for superior superheat control, reliability, and energy efficiency at all operating conditions.
14. Filter drier standard on all models (not shown).
15. Rugged baserail included for improved installation and handling.

Comfort Alert™ Diagnostics – Faster Service And Improved Accuracy (5 Ton RSPL 2-Stage Model Only)

The Comfort Alert™ diagnostics module is a breakthrough innovation for troubleshooting air conditioning system failures. The module is installed in the control box near the compressor contactor. By monitoring and analyzing data from the Scroll® compressor and the thermostat demand, the module can accurately detect the cause of electrical and system related failures without any sensors. A flashing LED indicator communicates the ALERT code and guides the service technician more quickly and accurately to the root cause of a problem.

NOTE: Single phase module does not provide safety protection! The Comfort Alert module is a monitoring device and cannot control or shut down the compressor unless used with a White-Rodgers 1F95-CA397 thermostat.

NOTE: Three phase module provides compressor protection and will shut down the compressor when compressor damaging conditions are detected.



MODEL IDENTIFICATION—RSNL-/RSPL- SERIES



R S N L — B 036 J K 010 X X X

Factory Installed Options
(See Next Page)

Heating Capacity (Factory Installed)
000 = No Resistance Heat
005 = 05 KW Resistance Heat (024-030)
010 = 10 KW Resistance Heat (024-060)
015 = 15 KW Resistance Heat (036-060)

Drive Package
K = Direct Drive

Electrical Designation
J = 208-230V—1PH—60 Hz
C = 208-230V—3PH—60 Hz

Cooling Capacity (BTUH) [kW]
024 = 24,000 [7.03]
030 = 30,000 [8.79]
036 = 36,000 [10.55]
042 = 42,000 [12.31]
048 = 48,000 [14.07]
060 = 60,000 [17.59]

Future Technical Variations
B = 1st Variation
C = 2nd Variation

Design Series (R-410A)

Efficiency Designation
N = 13 SEER
P = 14 SEER

Product Classification
S = Package Air Conditioner

Tradebrand
R = Rheem

[] Designates Metric Conversions



Instructions for Factory Installed Option(s) Selection

Note: Two characters following the model number will be utilized to designate a factory-installed option or combination of options. If no factory option(s) is required, nothing follows the model number.

Step 1. After a basic rooftop model is selected, choose a *two-character* option code from the FACTORY INSTALLED OPTION SELECTION TABLE.

FACTORY INSTALLED OPTION CODES

Option Code	Side Flow
AA	No Option
AK	x

Example: RSNL-036JK000**XX** (where **XX** is factory installed option)

Example: No Options

RSNL-036JK000

Example: Options with Sideflow

RSNL-036JK000AK

Note: Factory installed economizer is not available on these models.



NOMINAL SIZES 2-5 TONS [7.0-17.6 kW]

Model RSNL- Series	B024JK	B030JK	B036CK	B036JK
Cooling Performance¹				CONTINUED →
Gross Cooling Capacity Btu [kW]	24,400 [7.15]	29,800 [8.73]	37,000 [10.84]	37,000 [10.84]
EER/SEER ²	11.1/13	11.1/13	11.3/13	11.3/13
Nominal CFM/ARI Rated CFM [L/s]	800/800 [378/378]	1000/1000 [472/472]	1200/1200 [566/566]	1200/1200 [566/566]
ARI Net Cooling Capacity Btu [kW]	23,600 [6.91]	28,600 [8.38]	35,600 [10.43]	35,600 [10.43]
Net Sensible Capacity Btu [kW]	17,340 [5.08]	20,810 [6.1]	26,390 [7.73]	26,390 [7.73]
Net Latent Capacity Btu [kW]	6,260 [1.83]	7,790 [2.28]	9,210 [2.7]	9,210 [2.7]
Net System Power kW	2.12	2.58	3.15	3.15
Compressor				
No./Type	1/Scroll	1/Scroll	1/Scroll	1/Scroll
Outdoor Sound Rating (dB)³	76	76	76	76
Outdoor Coil—Fin Type	Louvered	Louvered	Louvered	Louvered
Tube Type	Rifled	Rifled	Rifled	Rifled
Tube Size in. [mm] OD	0.375 [9.5]	0.375 [9.5]	0.375 [9.5]	0.375 [9.5]
Face Area sq. ft. [sq. m]	10.56 [0.98]	10.56 [0.98]	14.8 [1.37]	14.8 [1.37]
Rows / FPI [FPcm]	1 / 18 [7]	1 / 18 [7]	1 / 22 [9]	1 / 22 [9]
Indoor Coil—Fin Type	Louvered	Louvered	Louvered	Louvered
Tube Type	Rifled	Rifled	Rifled	Rifled
Tube Size in. [mm]	0.375 [9.5]	0.375 [9.5]	0.375 [9.5]	0.375 [9.5]
Face Area sq. ft. [sq. m]	5.54 [0.51]	5.54 [0.51]	5.54 [0.51]	5.54 [0.51]
Rows / FPI [FPcm]	2 / 15 [6]	2 / 15 [6]	2 / 15 [6]	2 / 15 [6]
Refrigerant Control	TX Valves	TX Valves	TX Valves	TX Valves
Drain Connection No./Size in. [mm]	1/0.75 [19.05]	1/0.75 [19.05]	1/0.75 [19.05]	1/0.75 [19.05]
Outdoor Fan—Type	Propeller	Propeller	Propeller	Propeller
No. Used/Diameter in. [mm]	1/22 [558.8]	1/22 [558.8]	1/22 [558.8]	1/22 [558.8]
Drive Type/No. Speeds	Direct/1	Direct/1	Direct/1	Direct/1
CFM [L/s]	2500 [1180]	2500 [1180]	2700 [1274]	2700 [1274]
No. Motors/HP	1 at 1/5 HP	1 at 1/5 HP	1 at 1/5 HP	1 at 1/5 HP
Motor RPM	1075	1075	1075	1075
Indoor Fan—Type	FC Centrifugal	FC Centrifugal	FC Centrifugal	FC Centrifugal
No. Used/Diameter in. [mm]	1/9x7 [228.6x177.8]	1/10x9 [254x228.6]	1/10x9 [254x228.6]	1/10x9 [254x228.6]
Drive Type/No. Speeds	Direct/2	Direct/3	Direct/3	Direct/3
No. Motors	1	1	1	1
Motor HP	1/4	1/2	1/2	1/2
Motor RPM	1075	1075	1075	1075
Motor Frame Size	48	48	48	48
Filter—Type	Field Supplied	Field Supplied	Field Supplied	Field Supplied
Furnished	No	No	No	No
(No.) Size Recommended in. [mm]	(1)1x20x20 [25x508x508]	(1)1x24x24 [25x610x610]	(1)1x24x24 [25x610x610]	(1)1x24x24 [25x610x610]
Refrigerant Charge Oz. [g]	77.8 [2206]	76.8 [2177]	92.8 [2631]	92.8 [2631]
Weights				
Net Weight lbs. [kg]	381 [173]	399 [181]	412 [187]	412 [187]
Ship Weight lbs. [kg]	421 [191]	439 [199]	452 [205]	452 [205]

See Page 13 for Notes.

[] Designates Metric Conversions



NOMINAL SIZES 2-5 TONS [7.0-17.6 kW]

Model RSNL- Series	B042CK	B042JK	B048CK	B048JK
Cooling Performance¹				CONTINUED →
Gross Cooling Capacity Btu [kW]	44,000 [12.89]	44,000 [12.89]	50,000 [14.65]	50,000 [14.65]
EER/SEER ²	11.2/13	11.2/13	11.2/13	11.2/13
Nominal CFM/ARI Rated CFM [L/s]	1400/1400 [661/661]	1400/1400 [661/661]	1600/1600 [755/755]	1600/1600 [755/755]
ARI Net Cooling Capacity Btu [kW]	42,000 [12.31]	42,000 [12.31]	48,000 [14.06]	48,000 [14.06]
Net Sensible Capacity Btu [kW]	30,510 [8.94]	30,510 [8.94]	33,990 [9.96]	33,990 [9.96]
Net Latent Capacity Btu [kW]	11,490 [3.37]	11,490 [3.37]	14,010 [4.1]	14,010 [4.1]
Net System Power kW	3.73	3.73	4.28	4.28
Compressor				
No./Type	1/Scroll	1/Scroll	1/Scroll	1/Scroll
Outdoor Sound Rating (dB)³	76	76	78	78
Outdoor Coil—Fin Type	Louvered	Louvered	Louvered	Louvered
Tube Type	Rifled	Rifled	Rifled	Rifled
Tube Size in. [mm] OD	0.375 [9.5]	0.375 [9.5]	0.375 [9.5]	0.375 [9.5]
Face Area sq. ft. [sq. m]	16.65 [1.55]	16.65 [1.55]	16.23 [1.51]	16.23 [1.51]
Rows / FPI [FPcm]	1 / 22 [9]	1 / 22 [9]	2 / 22 [9]	2 / 22 [9]
Indoor Coil—Fin Type	Louvered	Louvered	Louvered	Louvered
Tube Type	Rifled	Rifled	Rifled	Rifled
Tube Size in. [mm]	0.375 [9.5]	0.375 [9.5]	0.375 [9.5]	0.375 [9.5]
Face Area sq. ft. [sq. m]	7.39 [0.69]	7.39 [0.69]	7.39 [0.69]	7.39 [0.69]
Rows / FPI [FPcm]	2 / 15 [6]	2 / 15 [6]	2 / 15 [6]	2 / 15 [6]
Refrigerant Control	TX Valves	TX Valves	TX Valves	TX Valves
Drain Connection No./Size in. [mm]	1/0.75 [19.05]	1/0.75 [19.05]	1/0.75 [19.05]	1/0.75 [19.05]
Outdoor Fan—Type	Propeller	Propeller	Propeller	Propeller
No. Used/Diameter in. [mm]	1/22 [558.8]	1/22 [558.8]	1/22 [558.8]	1/22 [558.8]
Drive Type/No. Speeds	Direct/1	Direct/1	Direct/1	Direct/1
CFM [L/s]	3500 [1652]	3500 [1652]	3300 [1557]	3300 [1557]
No. Motors/HP	1 at 1/3 HP	1 at 1/3 HP	1 at 1/3 HP	1 at 1/3 HP
Motor RPM	1075	1075	1075	1075
Indoor Fan—Type	FC Centrifugal	FC Centrifugal	FC Centrifugal	FC Centrifugal
No. Used/Diameter in. [mm]	1/10x9 [254x228.6]	1/10x9 [254x228.6]	1/10x9 [254x228.6]	1/10x9 [254x228.6]
Drive Type/No. Speeds	Direct/3	Direct/3	Direct/3	Direct/3
No. Motors	1	1	1	1
Motor HP	1/2	1/2	3/4	3/4
Motor RPM	1075	1075	1075	1075
Motor Frame Size	48	48	48	48
Filter—Type	Field Supplied	Field Supplied	Field Supplied	Field Supplied
Furnished	No	No	No	No
(No.) Size Recommended in. [mm]	(1)1x24x24 [25x610x610]	(1)1x24x24 [25x610x610]	(1)1x24x24 [25x610x610]	(1)1x24x24 [25x610x610]
Refrigerant Charge Oz. [g]	112 [3175]	112 [3175]	161.2 [4570]	161.2 [4570]
Weights				
Net Weight lbs. [kg]	422 [191]	422 [191]	452 [205]	461 [209]
Ship Weight lbs. [kg]	462 [210]	462 [210]	492 [223]	501 [227]

See Page 13 for Notes.

[] Designates Metric Conversions



NOMINAL SIZES 2-5 TONS [7.0-17.6 kW]

Model RSNL- Series	C060CK	C060JK
Cooling Performance¹		
Gross Cooling Capacity Btu [kW]	59,500 [17.43]	59,500 [17.43]
EER/SEER ²	10.5/13	10.5/13
Nominal CFM/ARI Rated CFM [L/s]	1900/1850 [897/873]	1900/1850 [897/873]
ARI Net Cooling Capacity Btu [kW]	57,500 [16.85]	57,500 [16.85]
Net Sensible Capacity Btu [kW]	40,460 [11.85]	40,460 [11.85]
Net Latent Capacity Btu [kW]	17,040 [4.99]	17,040 [4.99]
Net System Power kW	5.48	5.48
Compressor		
No./Type	1/Scroll	1/Scroll
Outdoor Sound Rating (dB)³		
	78	78
Outdoor Coil—Fin Type		
	Louvered	Louvered
Tube Type	Rifled	Rifled
Tube Size in. [mm] OD	0.375 [9.5]	0.375 [9.5]
Face Area sq. ft. [sq. m]	16.23 [1.51]	16.23 [1.51]
Rows / FPI [FPcm]	2 / 22 [9]	2 / 22 [9]
Indoor Coil—Fin Type		
	Louvered	Louvered
Tube Type	Rifled	Rifled
Tube Size in. [mm]	0.375 [9.5]	0.375 [9.5]
Face Area sq. ft. [sq. m]	7.39 [0.69]	7.39 [0.69]
Rows / FPI [FPcm]	2 / 15 [6]	2 / 15 [6]
Refrigerant Control	TX Valves	TX Valves
Drain Connection No./Size in. [mm]	1/0.75 [19.05]	1/0.75 [19.05]
Outdoor Fan—Type		
	Propeller	Propeller
No. Used/Diameter in. [mm]	1/22 [558.8]	1/22 [558.8]
Drive Type/No. Speeds	Direct/1	Direct/1
CFM [L/s]	3300 [1557]	3300 [1557]
No. Motors/HP	1 at 1/3 HP	1 at 1/3 HP
Motor RPM	1075	1075
Indoor Fan—Type		
	FC Centrifugal	FC Centrifugal
No. Used/Diameter in. [mm]	1/12x9 [304.8x228.6]	1/12x9 [304.8x228.6]
Drive Type/No. Speeds	Direct/4	Direct/4
No. Motors	1	1
Motor HP	1	1
Motor RPM	1075	1075
Motor Frame Size	48	48
Filter—Type		
	Field Supplied	Field Supplied
Furnished	No	No
(No.) Size Recommended in. [mm]	(1)1x24x30 [25x610x762]	(1)1x24x30 [25x610x762]
Refrigerant Charge Oz. [g]		
	172.8 [4899]	172.8 [4899]
Weights		
Net Weight lbs. [kg]	532 [241]	532 [241]
Ship Weight lbs. [kg]	577 [262]	577 [262]

See Page 13 for Notes.

[] Designates Metric Conversions



NOMINAL SIZES 2-5 TONS [7.0-17.6 kW]

Model RSPL- Series	B024JK	B030JK	B036CK	B036JK
Cooling Performance¹				CONTINUED →
Gross Cooling Capacity Btu [kW]	24,400 [7.15]	29,600 [8.67]	36,800 [10.78]	36,800 [10.78]
EER/SEER ²	12/14	12/14	12/14	12/14
Nominal CFM/ARI Rated CFM [L/s]	800/800 [378/378]	1000/1000 [472/472]	1200/1200 [566/566]	1200/1200 [566/566]
ARI Net Cooling Capacity Btu [kW]	24,000 [7.03]	29,200 [8.56]	36,000 [10.55]	36,000 [10.55]
Net Sensible Capacity Btu [kW]	17,790 [5.21]	21,700 [6.36]	26,420 [7.74]	26,420 [7.74]
Net Latent Capacity Btu [kW]	6,210 [1.82]	7,500 [2.2]	9,580 [2.81]	9,580 [2.81]
Net System Power kW	2.01	2.43	3	3
Compressor				
No./Type	1/Scroll	1/Scroll	1/Scroll	1/Scroll
Outdoor Sound Rating (dB)³	76	76	76	76
Outdoor Coil—Fin Type	Louvered	Louvered	Louvered	Louvered
Tube Type	Rifled	Rifled	Rifled	Rifled
Tube Size in. [mm] OD	0.375 [9.5]	0.375 [9.5]	0.375 [9.5]	0.375 [9.5]
Face Area sq. ft. [sq. m]	10.56 [0.98]	10.56 [0.98]	14.8 [1.37]	14.8 [1.37]
Rows / FPI [FPcm]	1 / 18 [7]	1 / 18 [7]	1 / 22 [9]	1 / 22 [9]
Indoor Coil—Fin Type	Louvered	Louvered	Louvered	Louvered
Tube Type	Rifled	Rifled	Rifled	Rifled
Tube Size in. [mm]	0.375 [9.5]	0.375 [9.5]	0.375 [9.5]	0.375 [9.5]
Face Area sq. ft. [sq. m]	5.54 [0.51]	5.54 [0.51]	5.54 [0.51]	5.54 [0.51]
Rows / FPI [FPcm]	2 / 15 [6]	2 / 15 [6]	2 / 15 [6]	2 / 15 [6]
Refrigerant Control	TX Valves	TX Valves	TX Valves	TX Valves
Drain Connection No./Size in. [mm]	1/0.75 [19.05]	1/0.75 [19.05]	1/0.75 [19.05]	1/0.75 [19.05]
Outdoor Fan—Type	Propeller	Propeller	Propeller	Propeller
No. Used/Diameter in. [mm]	1/22 [558.8]	1/22 [558.8]	1/22 [558.8]	1/22 [558.8]
Drive Type/No. Speeds	Direct/1	Direct/1	Direct/1	Direct/1
CFM [L/s]	2500 [1180]	2500 [1180]	2700 [1274]	2700 [1274]
No. Motors/HP	1 at 1/5 HP	1 at 1/5 HP	1 at 1/5 HP	1 at 1/5 HP
Motor RPM	1075	1075	1075	1075
Indoor Fan—Type	FC Centrifugal	FC Centrifugal	FC Centrifugal	FC Centrifugal
No. Used/Diameter in. [mm]	1/9x7 [228.6x177.8]	1/10x9 [254x228.6]	1/10x9 [254x228.6]	1/10x9 [254x228.6]
Drive Type/No. Speeds	Direct/2	Direct/3	Direct/3	Direct/3
No. Motors	1	1	1	1
Motor HP	1/3	1/2	1/2	1/2
Motor RPM	1075	1075	1075	1075
Motor Frame Size	48	48	48	48
Filter—Type	Field Supplied	Field Supplied	Field Supplied	Field Supplied
Furnished	No	No	No	No
(No.) Size Recommended in. [mm]	(1)1x20x20 [25x508x508]	(1)1x24x24 [25x610x610]	(1)1x24x24 [25x610x610]	(1)1x24x24 [25x610x610]
Refrigerant Charge Oz. [g]	77.8 [2206]	76.8 [2177]	92.8 [2631]	92.8 [2631]
Weights				
Net Weight lbs. [kg]	381 [173]	399 [181]	412 [187]	412 [187]
Ship Weight lbs. [kg]	421 [191]	439 [199]	452 [205]	452 [205]

See Page 13 for Notes.

[] Designates Metric Conversions



NOMINAL SIZES 2-5 TONS [7.0-17.6 kW]

Model RSPL- Series	B042CK	B042JK	B048CK	B048JK
Cooling Performance¹				CONTINUED →
Gross Cooling Capacity Btu [kW]	44,000 [12.89]	44,000 [12.89]	50,500 [14.8]	50,500 [14.8]
EER/SEER ²	12/14	12/14	12/14	12/14
Nominal CFM/ARI Rated CFM [L/s]	1400/1400 [661/661]	1400/1400 [661/661]	1600/1600 [755/755]	1600/1600 [755/755]
ARI Net Cooling Capacity Btu [kW]	43,000 [12.6]	43,000 [12.6]	49,000 [14.36]	49,000 [14.36]
Net Sensible Capacity Btu [kW]	31,270 [9.16]	31,270 [9.16]	34,990 [10.25]	34,990 [10.25]
Net Latent Capacity Btu [kW]	11,730 [3.44]	11,730 [3.44]	14,010 [4.1]	14,010 [4.1]
Net System Power kW	3.58	3.58	4.08	4.08
Compressor				
No./Type	1/Scroll	1/Scroll	1/Scroll	1/Scroll
Outdoor Sound Rating (dB)³	76	76	78	78
Outdoor Coil—Fin Type	Louvered	Louvered	Louvered	Louvered
Tube Type	Rifled	Rifled	Rifled	Rifled
Tube Size in. [mm] OD	0.375 [9.5]	0.375 [9.5]	0.375 [9.5]	0.375 [9.5]
Face Area sq. ft. [sq. m]	16.65 [1.55]	16.65 [1.55]	16.23 [1.51]	16.23 [1.51]
Rows / FPI [FPcm]	1 / 22 [9]	1 / 22 [9]	2 / 22 [9]	2 / 22 [9]
Indoor Coil—Fin Type	Louvered	Louvered	Louvered	Louvered
Tube Type	Rifled	Rifled	Rifled	Rifled
Tube Size in. [mm]	0.375 [9.5]	0.375 [9.5]	0.375 [9.5]	0.375 [9.5]
Face Area sq. ft. [sq. m]	7.39 [0.69]	7.39 [0.69]	7.39 [0.69]	7.39 [0.69]
Rows / FPI [FPcm]	2 / 15 [6]	2 / 15 [6]	2 / 15 [6]	2 / 15 [6]
Refrigerant Control	TX Valves	TX Valves	TX Valves	TX Valves
Drain Connection No./Size in. [mm]	1/0.75 [19.05]	1/0.75 [19.05]	1/0.75 [19.05]	1/0.75 [19.05]
Outdoor Fan—Type	Propeller	Propeller	Propeller	Propeller
No. Used/Diameter in. [mm]	1/22 [558.8]	1/22 [558.8]	1/22 [558.8]	1/22 [558.8]
Drive Type/No. Speeds	Direct/1	Direct/1	Direct/1	Direct/1
CFM [L/s]	3500 [1652]	3500 [1652]	3300 [1557]	3300 [1557]
No. Motors/HP	1 at 1/3 HP	1 at 1/3 HP	1 at 1/3 HP	1 at 1/3 HP
Motor RPM	1075	1075	1075	1075
Indoor Fan—Type	FC Centrifugal	FC Centrifugal	FC Centrifugal	FC Centrifugal
No. Used/Diameter in. [mm]	1/10x9 [254x228.6]	1/10x9 [254x228.6]	1/10x9 [254x228.6]	1/10x9 [254x228.6]
Drive Type/No. Speeds	Direct/3	Direct/3	Direct/3	Direct/3
No. Motors	1	1	1	1
Motor HP	1/2	1/2	3/4	3/4
Motor RPM	1075	1075	1075	1075
Motor Frame Size	48	48	48	48
Filter—Type	Field Supplied	Field Supplied	Field Supplied	Field Supplied
Furnished	No	No	No	No
(No.) Size Recommended in. [mm]	(1)1x24x24 [25x610x610]	(1)1x24x24 [25x610x610]	(1)1x24x24 [25x610x610]	(1)1x24x24 [25x610x610]
Refrigerant Charge Oz. [g]	112 [3175]	112 [3175]	161.2 [4570]	161.2 [4570]
Weights				
Net Weight lbs. [kg]	422 [191]	422 [191]	452 [205]	461 [209]
Ship Weight lbs. [kg]	462 [210]	462 [210]	492 [223]	501 [227]

See Page 13 for Notes.

[] Designates Metric Conversions



NOMINAL SIZES 2-5 TONS [7.0-17.6 kW]

Model RSPL- Series	B060CK	B060JK
Cooling Performance¹		
Gross Cooling Capacity Btu [kW]	59,500 [17.43]	59,500 [17.43]
EER/SEER ²	10.8/14	10.8/14
Nominal CFM/ARI Rated CFM [L/s]	1900/1850 [897/873]	1900/1850 [897/873]
ARI Net Cooling Capacity Btu [kW]	57,500 [16.85]	57,500 [16.85]
Net Sensible Capacity Btu [kW]	40,460 [11.85]	40,460 [11.85]
Net Latent Capacity Btu [kW]	17,040 [4.99]	17,040 [4.99]
Net System Power kW	5.32	5.32
Compressor		
No./Type	1/Scroll	1/Scroll
Outdoor Sound Rating (dB)³		
	78	78
Outdoor Coil—Fin Type		
	Louvered	Louvered
Tube Type	Rifled	Rifled
Tube Size in. [mm] OD	0.375 [9.5]	0.375 [9.5]
Face Area sq. ft. [sq. m]	16.23 [1.51]	16.23 [1.51]
Rows / FPI [FPcm]	2 / 22 [9]	2 / 22 [9]
Indoor Coil—Fin Type		
	Louvered	Louvered
Tube Type	Rifled	Rifled
Tube Size in. [mm]	0.375 [9.5]	0.375 [9.5]
Face Area sq. ft. [sq. m]	7.39 [0.69]	7.39 [0.69]
Rows / FPI [FPcm]	2 / 15 [6]	2 / 15 [6]
Refrigerant Control	TX Valves	TX Valves
Drain Connection No./Size in. [mm]	1/0.75 [19.05]	1/0.75 [19.05]
Outdoor Fan—Type		
	Propeller	Propeller
No. Used/Diameter in. [mm]	1/22 [558.8]	1/22 [558.8]
Drive Type/No. Speeds	Direct/1	Direct/1
CFM [L/s]	3300 [1557]	3300 [1557]
No. Motors/HP	1 at 1/3 HP	1 at 1/3 HP
Motor RPM	1075	1075
Indoor Fan—Type		
	FC Centrifugal	FC Centrifugal
No. Used/Diameter in. [mm]	1/12x9 [304.8x228.6]	1/12x9 [304.8x228.6]
Drive Type/No. Speeds	Direct/4	Direct/4
No. Motors	1	1
Motor HP	1	1
Motor RPM	1075	1075
Motor Frame Size	48	48
Filter—Type		
	Field Supplied	Field Supplied
Furnished	No	No
(No.) Size Recommended in. [mm]	(1)1x24x30 [25x610x762]	(1)1x24x30 [25x610x762]
Refrigerant Charge Oz. [g]		
	172.8 [4899]	172.8 [4899]
Weights		
Net Weight lbs. [kg]	532 [241]	532 [241]
Ship Weight lbs. [kg]	577 [262]	577 [262]

See Page 13 for Notes.

[] Designates Metric Conversions



NOTES:

1. Cooling Performance is rated at 95° F ambient, 80° F entering dry bulb, 67° F entering wet bulb. Gross capacity does not include the effect of fan motor heat. ARI capacity is net and includes the effect of fan motor heat. Units are suitable for operation in CFM range shown in airflow tables. Units are certified in accordance with the Unitary Air Conditioner Equipment certification program, which is based on ARI Standard 210/240 or 360.
2. EER and/or SEER are rated at ARI conditions and in accordance with DOE test procedures.
3. Outdoor Sound Rating shown is tested in accordance with ARI Standard 270.



GROSS SYSTEMS PERFORMANCE DATA—B024

		ENTERING INDOOR AIR @ 80°F [26.7°C] dbE ①									
wbE		71°F [21.7°C]			67°F [19.4°C]			63°F [17.2°C]			
CFM [L/s]		880 [415]	800 [378]	680 [321]	880 [415]	800 [378]	680 [321]	880 [415]	800 [378]	680 [321]	
DR ①		.19	.17	.16	.19	.17	.16	.19	.17	.16	
OUTDOOR DRY BULB TEMPERATURE °F [°C]	75 [23.9]	Total BTUH [kW] Sens BTUH [kW] Power	29.6 [8.67] 17.6 [5.16] 1.5	29.0 [8.50] 16.8 [4.92] 1.5	28.5 [8.35] 16.0 [4.69] 1.5	27.8 [8.15] 20.7 [6.07] 1.5	27.3 [8.00] 19.8 [5.80] 1.5	26.8 [7.85] 18.8 [5.51] 1.5	26.6 [7.80] 22.1 [6.48] 1.5	26.1 [7.65] 21.2 [6.21] 1.5	25.7 [7.53] 20.2 [5.92] 1.5
	80 [26.7]	Total BTUH [kW] Sens BTUH [kW] Power	29.0 [8.50] 17.3 [5.07] 1.6	28.5 [8.35] 16.5 [4.84] 1.6	28.0 [8.21] 15.7 [4.60] 1.6	27.2 [7.97] 20.3 [5.95] 1.6	26.8 [7.85] 19.4 [5.69] 1.6	26.3 [7.71] 18.5 [5.42] 1.6	26.0 [7.62] 21.8 [6.39] 1.6	25.6 [7.50] 20.8 [6.10] 1.6	25.1 [7.36] 19.9 [5.83] 1.6
	85 [29.4]	Total BTUH [kW] Sens BTUH [kW] Power	28.3 [8.29] 16.9 [4.95] 1.7	27.8 [8.15] 16.1 [4.72] 1.7	27.3 [8.00] 15.4 [4.51] 1.7	26.5 [7.77] 19.9 [5.83] 1.7	26.1 [7.65] 19.0 [5.57] 1.7	25.6 [7.50] 18.1 [5.30] 1.7	25.3 [7.41] 21.4 [6.27] 1.7	24.9 [7.30] 20.4 [5.98] 1.7	24.4 [7.15] 19.5 [5.71] 1.7
	90 [32.2]	Total BTUH [kW] Sens BTUH [kW] Power	27.5 [8.06] 16.4 [4.81] 1.8	27.0 [7.91] 15.7 [4.60] 1.8	26.5 [7.77] 14.9 [4.37] 1.8	25.7 [7.53] 19.5 [5.71] 1.8	25.3 [7.41] 18.6 [5.45] 1.8	24.8 [7.27] 17.7 [5.19] 1.8	24.5 [7.18] 20.9 [6.13] 1.8	24.1 [7.06] 20.0 [5.86] 1.8	23.7 [6.95] 19.1 [5.60] 1.8
	95 [35]	Total BTUH [kW] Sens BTUH [kW] Power	26.6 [7.80] 15.9 [4.66] 1.9	26.1 [7.65] 15.2 [4.45] 1.9	25.7 [7.53] 14.5 [4.25] 1.9	24.9 [7.30] 19.0 [5.57] 1.9	24.4 [7.15] 18.2 [5.33] 1.9	24.0 [7.03] 17.3 [5.07] 1.9	23.7 [6.95] 20.5 [6.01] 1.9	23.2 [6.80] 19.6 [5.74] 1.9	22.8 [6.68] 18.6 [5.45] 1.9
	100 [37.8]	Total BTUH [kW] Sens BTUH [kW] Power	25.7 [7.53] 15.5 [4.54] 2.0	25.3 [7.41] 14.8 [4.34] 2.0	24.8 [7.27] 14.1 [4.13] 2.0	24.0 [7.03] 18.6 [5.45] 2.0	23.5 [6.89] 17.8 [5.22] 2.0	23.1 [6.77] 16.9 [4.95] 2.0	22.8 [6.68] 20.0 [5.86] 2.0	22.4 [6.56] 19.2 [5.63] 2.0	22.0 [6.45] 18.3 [5.36] 2.0
	105 [40.6]	Total BTUH [kW] Sens BTUH [kW] Power	24.9 [7.30] 15.1 [4.43] 2.1	24.4 [7.15] 14.5 [4.25] 2.1	24.0 [7.03] 13.8 [4.04] 2.1	23.1 [6.77] 18.2 [5.33] 2.1	22.7 [6.65] 17.4 [5.10] 2.1	22.3 [6.54] 16.6 [4.86] 2.1	21.9 [6.42] 19.7 [5.77] 2.1	21.5 [6.30] 18.8 [5.51] 2.1	21.1 [6.18] 17.9 [5.25] 2.1
	110 [43.3]	Total BTUH [kW] Sens BTUH [kW] Power	24.0 [7.03] 14.9 [4.37] 2.2	23.6 [6.92] 14.2 [4.16] 2.2	23.2 [6.80] 13.6 [3.99] 2.1	22.3 [6.54] 18.0 [5.28] 2.2	21.9 [6.42] 17.2 [5.04] 2.2	21.5 [6.30] 16.4 [4.81] 2.1	21.1 [6.18] 19.4 [5.69] 2.2	20.7 [6.07] 18.6 [5.45] 2.2	20.3 [5.95] 17.7 [5.19] 2.1
	115 [46.1]	Total BTUH [kW] Sens BTUH [kW] Power	23.3 [6.83] 14.8 [4.34] 2.3	22.9 [6.71] 14.1 [4.13] 2.3	22.4 [6.56] 13.4 [3.93] 2.2	21.5 [6.30] 17.8 [5.22] 2.3	21.1 [6.18] 17.0 [4.98] 2.3	20.8 [6.10] 16.2 [4.75] 2.2	20.3 [5.95] 19.3 [5.66] 2.3	20.0 [5.86] 18.4 [5.39] 2.3	19.6 [5.74] 17.6 [5.16] 2.2

GROSS SYSTEMS PERFORMANCE DATA—B030

		ENTERING INDOOR AIR @ 80°F [26.7°C] dbE ①									
wbE		71°F [21.7°C]			67°F [19.4°C]			63°F [17.2°C]			
CFM [L/s]		1100 [519]	1000 [472]	850 [401]	1100 [519]	1000 [472]	850 [401]	1100 [519]	1000 [472]	850 [401]	
DR ①		.22	.20	.19	.22	.20	.19	.22	.20	.19	
OUTDOOR DRY BULB TEMPERATURE °F [°C]	75 [23.9]	Total BTUH [kW] Sens BTUH [kW] Power	36.7 [10.76] 21.3 [6.24] 1.8	36.0 [10.55] 20.4 [5.98] 1.8	35.4 [10.37] 19.4 [5.69] 1.8	34.5 [10.11] 25.4 [7.44] 1.8	33.9 [9.94] 24.3 [7.12] 1.8	33.3 [9.76] 23.2 [6.80] 1.8	33.1 [9.70] 27.1 [7.94] 1.8	32.6 [9.55] 25.9 [7.59] 1.8	32.0 [9.38] 24.7 [7.24] 1.8
	80 [26.7]	Total BTUH [kW] Sens BTUH [kW] Power	35.8 [10.49] 20.7 [6.07] 1.9	35.2 [10.32] 19.8 [5.80] 1.9	34.5 [10.11] 18.9 [5.54] 1.9	33.6 [9.85] 24.8 [7.27] 1.9	33.0 [9.67] 23.7 [6.95] 1.9	32.4 [9.50] 22.6 [6.62] 1.9	32.2 [9.44] 26.5 [7.77] 1.9	31.7 [9.29] 25.3 [7.41] 1.9	31.1 [9.11] 24.1 [7.06] 1.9
	85 [29.4]	Total BTUH [kW] Sens BTUH [kW] Power	34.8 [10.20] 20.1 [5.89] 2.0	34.2 [10.02] 19.2 [5.63] 2.0	33.5 [9.82] 18.3 [5.36] 2.0	32.6 [9.55] 24.2 [7.09] 2.0	32.0 [9.38] 23.1 [6.77] 2.0	31.4 [9.20] 22.0 [6.45] 2.0	31.2 [9.14] 25.9 [7.59] 2.0	30.7 [9.00] 24.7 [7.24] 2.0	30.1 [8.82] 23.6 [6.92] 2.0
	90 [32.2]	Total BTUH [kW] Sens BTUH [kW] Power	33.7 [9.88] 19.5 [5.71] 2.2	33.1 [9.70] 18.6 [5.45] 2.1	32.5 [9.52] 17.7 [5.19] 2.1	31.5 [9.23] 23.6 [6.92] 2.2	30.9 [9.06] 22.5 [6.59] 2.1	30.3 [8.88] 21.5 [6.30] 2.1	30.1 [8.82] 25.2 [7.39] 2.1	29.6 [8.67] 24.1 [7.06] 2.1	29.0 [8.50] 23.0 [6.74] 2.1
	95 [35]	Total BTUH [kW] Sens BTUH [kW] Power	32.5 [9.52] 18.8 [5.51] 2.3	31.9 [9.35] 18.0 [5.28] 2.2	31.3 [9.17] 17.2 [5.04] 2.2	30.3 [8.88] 23.0 [6.74] 2.3	29.7 [8.70] 21.9 [6.42] 2.2	29.2 [8.56] 20.9 [6.13] 2.2	28.9 [8.47] 24.6 [7.21] 2.3	28.4 [8.32] 23.5 [6.89] 2.2	27.9 [8.18] 22.4 [6.56] 2.2
	100 [37.8]	Total BTUH [kW] Sens BTUH [kW] Power	31.2 [9.14] 18.2 [5.33] 2.4	30.6 [8.97] 17.4 [5.10] 2.4	30.1 [8.82] 16.6 [4.86] 2.3	29.0 [8.50] 22.3 [6.54] 2.4	28.5 [8.35] 21.3 [6.24] 2.4	28.0 [8.21] 20.3 [5.95] 2.3	27.7 [8.12] 24.0 [7.03] 2.4	27.2 [7.97] 22.9 [6.71] 2.4	26.7 [7.83] 21.8 [6.39] 2.3
	105 [40.6]	Total BTUH [kW] Sens BTUH [kW] Power	29.9 [8.76] 17.5 [5.13] 2.5	29.4 [8.62] 16.7 [4.89] 2.5	28.8 [8.44] 16.0 [4.69] 2.5	27.7 [8.12] 21.6 [6.33] 2.5	27.2 [7.97] 20.7 [6.07] 2.5	26.7 [7.83] 19.7 [5.77] 2.5	26.3 [7.71] 23.3 [6.83] 2.5	25.9 [7.59] 22.3 [6.54] 2.5	25.4 [7.44] 21.2 [6.21] 2.4
	110 [43.3]	Total BTUH [kW] Sens BTUH [kW] Power	28.5 [8.35] 16.8 [4.92] 2.6	28.0 [8.21] 16.0 [4.69] 2.6	27.5 [8.06] 15.3 [4.48] 2.6	26.3 [7.71] 20.9 [6.13] 2.6	25.9 [7.59] 20.0 [5.86] 2.6	25.4 [7.44] 19.0 [5.57] 2.6	25.0 [7.33] 22.6 [6.62] 2.6	24.5 [7.18] 21.6 [6.33] 2.6	24.1 [7.06] 20.6 [6.04] 2.6
	115 [46.1]	Total BTUH [kW] Sens BTUH [kW] Power	27.2 [7.97] 16.0 [4.69] 2.7	26.7 [7.83] 15.3 [4.48] 2.7	26.2 [7.68] 14.6 [4.28] 2.7	25.0 [7.33] 20.1 [5.89] 2.7	24.5 [7.18] 19.2 [5.63] 2.7	24.1 [7.06] 18.3 [5.36] 2.7	23.6 [6.92] 21.8 [6.39] 2.7	23.2 [6.80] 20.8 [6.10] 2.7	22.8 [6.68] 19.8 [5.80] 2.7

DR —Depression ratio
dbE—Entering air dry bulb
wbE—Entering air wet bulb

Total —Total capacity x 1000 BTUH
Sens —Sensible capacity x 1000 BTUH
Power—KW input

NOTES: ① When the entering air dry bulb is other than 80°F [27°C], adjust the sensible capacity from the table by adding $[1.10 \times \text{CFM} \times (1 - \text{DR}) \times (\text{dbE} - 80)]$.

[] Designates Metric Conversions



SYSTEMS PERFORMANCE—RSNL- SERIES

GROSS SYSTEMS PERFORMANCE DATA—B036

		ENTERING INDOOR AIR @ 80°F [26.7°C] dbE ①									
wbE		71°F [21.7°C]			67°F [19.4°C]			63°F [17.2°C]			
CFM [L/s]		1320 [623]	1200 [566]	1080 [510]	1320 [623]	1200 [566]	1080 [510]	1320 [623]	1200 [566]	1080 [510]	
DR ①		.17	.15	.13	.17	.15	.13	.17	.15	.13	
OUTDOOR DRY BULB TEMPERATURE °F [°C]	75 [23.9]	Total BTUH [kW] Sens BTUH [kW] Power	44.9 [13.16] 26.5 [7.77] 2.3	44.1 [12.92] 25.3 [7.41] 2.2	43.3 [12.69] 24.1 [7.06] 2.2	42.3 [12.40] 31.6 [9.26] 2.2	41.5 [12.16] 30.2 [8.85] 2.2	40.7 [11.93] 28.8 [8.44] 2.2	40.6 [11.90] 33.5 [9.82] 2.2	39.9 [11.69] 32.0 [9.38] 2.2	39.2 [11.49] 30.5 [8.94] 2.2
	80 [26.7]	Total BTUH [kW] Sens BTUH [kW] Power	44.2 [12.95] 26.2 [7.68] 2.4	43.4 [12.72] 25.0 [7.33] 2.4	42.6 [12.48] 23.8 [6.98] 2.4	41.6 [12.19] 31.3 [9.17] 2.4	40.8 [11.96] 29.9 [8.76] 2.4	40.1 [11.75] 28.5 [8.35] 2.3	39.9 [11.69] 33.2 [9.73] 2.4	39.2 [11.49] 31.7 [9.29] 2.4	38.5 [11.28] 30.2 [8.85] 2.3
	85 [29.4]	Total BTUH [kW] Sens BTUH [kW] Power	43.1 [12.63] 25.6 [7.50] 2.5	42.4 [12.43] 24.4 [7.15] 2.5	41.6 [12.19] 23.3 [6.83] 2.5	40.5 [11.87] 30.7 [9.00] 2.5	39.8 [11.66] 29.3 [8.59] 2.5	39.1 [11.46] 27.9 [8.18] 2.5	38.9 [11.40] 32.6 [9.55] 2.5	38.2 [11.20] 31.1 [9.11] 2.5	37.5 [10.99] 29.7 [8.70] 2.5
	90 [32.2]	Total BTUH [kW] Sens BTUH [kW] Power	41.8 [12.25] 24.8 [7.27] 2.7	41.1 [12.05] 23.7 [6.95] 2.7	40.3 [11.81] 22.6 [6.62] 2.6	39.2 [11.49] 29.9 [8.76] 2.7	38.5 [11.28] 28.6 [8.38] 2.6	37.8 [11.08] 27.3 [8.00] 2.6	37.6 [11.02] 31.8 [9.32] 2.7	36.9 [10.81] 30.4 [8.91] 2.6	36.2 [10.61] 29.0 [8.50] 2.6
	95 [35]	Total BTUH [kW] Sens BTUH [kW] Power	40.3 [11.81] 24.0 [7.03] 2.8	39.6 [11.61] 22.9 [6.71] 2.8	38.9 [11.40] 21.9 [6.42] 2.8	37.7 [11.05] 29.1 [8.53] 2.8	37.0 [10.84] 27.8 [8.15] 2.8	36.4 [10.67] 26.5 [7.77] 2.8	36.1 [10.58] 31.0 [9.09] 2.8	35.4 [10.37] 29.6 [8.67] 2.8	34.8 [10.20] 28.3 [8.29] 2.8
	100 [37.8]	Total BTUH [kW] Sens BTUH [kW] Power	38.8 [11.37] 23.2 [6.80] 3.0	38.1 [11.17] 22.1 [6.48] 2.9	37.4 [10.96] 21.1 [6.18] 2.9	36.1 [10.58] 28.3 [8.29] 3.0	35.5 [10.40] 27.0 [7.91] 2.9	34.8 [10.20] 25.8 [7.56] 2.9	34.5 [10.11] 30.2 [8.85] 2.9	33.9 [9.94] 28.8 [8.44] 2.9	33.3 [9.76] 27.5 [8.06] 2.9
	105 [40.6]	Total BTUH [kW] Sens BTUH [kW] Power	37.2 [10.90] 22.4 [6.56] 3.1	36.5 [10.70] 21.4 [6.27] 3.1	35.9 [10.52] 20.4 [5.98] 3.1	34.6 [10.14] 27.5 [8.06] 3.1	34.0 [9.96] 26.3 [7.71] 3.1	33.3 [9.76] 25.0 [7.33] 3.0	32.9 [9.64] 29.4 [8.62] 3.1	32.3 [9.47] 28.1 [8.24] 3.1	31.8 [9.32] 26.8 [7.85] 3.0
	110 [43.3]	Total BTUH [kW] Sens BTUH [kW] Power	35.7 [10.46] 21.8 [6.39] 3.3	35.1 [10.29] 20.8 [6.10] 3.2	34.5 [10.11] 19.8 [5.80] 3.2	33.1 [9.70] 26.9 [7.88] 3.2	32.5 [9.52] 25.7 [7.53] 3.2	31.9 [9.35] 24.5 [7.18] 3.2	31.5 [9.23] 28.8 [8.44] 3.2	30.9 [9.06] 27.5 [8.06] 3.2	30.4 [8.91] 26.2 [7.68] 3.2
	115 [46.1]	Total BTUH [kW] Sens BTUH [kW] Power	34.5 [10.11] 21.3 [6.24] 3.4	33.9 [9.94] 20.4 [5.98] 3.4	33.3 [9.76] 19.4 [5.69] 3.3	31.9 [9.35] 26.4 [7.74] 3.4	31.3 [9.17] 25.2 [7.39] 3.4	30.7 [9.00] 24.1 [7.06] 3.3	30.2 [8.85] 28.3 [8.29] 3.4	29.7 [8.70] 27.1 [7.94] 3.3	29.2 [8.56] 25.8 [7.56] 3.3

GROSS SYSTEMS PERFORMANCE DATA—B042

		ENTERING INDOOR AIR @ 80°F [26.7°C] dbE ①									
wbE		71°F [21.7°C]			67°F [19.4°C]			63°F [17.2°C]			
CFM [L/s]		1540 [727]	1400 [661]	1260 [595]	1540 [727]	1400 [661]	1260 [595]	1540 [727]	1400 [661]	1260 [595]	
DR ①		.18	.17	.15	.18	.17	.15	.18	.17	.15	
OUTDOOR DRY BULB TEMPERATURE °F [°C]	75 [23.9]	Total BTUH [kW] Sens BTUH [kW] Power	53.6 [15.71] 31.1 [9.11] 2.6	52.6 [15.42] 29.7 [8.70] 2.6	51.7 [15.15] 28.3 [8.29] 2.6	50.3 [14.74] 36.6 [10.73] 2.6	49.4 [14.48] 34.9 [10.23] 2.6	48.5 [14.21] 33.3 [9.76] 2.6	48.6 [14.24] 39.7 [11.63] 2.6	47.7 [13.98] 37.9 [11.11] 2.6	46.8 [13.72] 36.2 [10.61] 2.6
	80 [26.7]	Total BTUH [kW] Sens BTUH [kW] Power	52.1 [15.27] 30.4 [8.91] 2.8	51.1 [14.98] 29.0 [8.50] 2.7	50.2 [14.71] 27.7 [8.12] 2.7	48.7 [14.27] 35.9 [10.52] 2.8	47.9 [14.04] 34.3 [10.05] 2.7	47.0 [13.77] 32.7 [9.58] 2.7	47.0 [13.77] 39.0 [11.43] 2.8	46.2 [13.54] 37.3 [10.93] 2.7	45.4 [13.31] 35.5 [10.40] 2.7
	85 [29.4]	Total BTUH [kW] Sens BTUH [kW] Power	50.6 [14.83] 29.7 [8.70] 2.9	49.7 [14.57] 28.4 [8.32] 2.9	48.8 [14.30] 27.1 [7.94] 2.9	47.3 [13.86] 35.2 [10.32] 2.9	46.4 [13.60] 33.6 [9.85] 2.9	45.6 [13.36] 32.0 [9.38] 2.9	45.6 [13.36] 38.3 [11.22] 2.9	44.8 [13.13] 36.6 [10.73] 2.9	44.0 [12.90] 34.9 [10.23] 2.9
	90 [32.2]	Total BTUH [kW] Sens BTUH [kW] Power	49.3 [14.45] 29.0 [8.50] 3.1	48.4 [14.18] 27.7 [8.12] 3.1	47.5 [13.92] 26.4 [7.74] 3.0	45.9 [13.45] 34.5 [10.11] 3.1	45.1 [13.22] 32.9 [9.64] 3.1	44.3 [12.98] 31.4 [9.20] 3.0	44.2 [12.95] 37.6 [11.02] 3.1	43.4 [12.72] 35.9 [10.52] 3.1	42.6 [12.48] 34.3 [10.05] 3.0
	95 [35]	Total BTUH [kW] Sens BTUH [kW] Power	47.9 [14.04] 28.3 [8.29] 3.2	47.1 [13.80] 27.1 [7.94] 3.2	46.2 [13.54] 25.8 [7.56] 3.2	44.6 [13.07] 33.8 [9.91] 3.2	43.8 [12.84] 32.3 [9.47] 3.2	43.0 [12.60] 30.8 [9.03] 3.2	42.9 [12.57] 36.9 [10.81] 3.2	42.1 [12.34] 35.3 [10.35] 3.2	41.4 [12.13] 33.6 [9.85] 3.2
	100 [37.8]	Total BTUH [kW] Sens BTUH [kW] Power	46.6 [13.66] 27.6 [8.09] 3.4	45.8 [13.42] 26.4 [7.74] 3.4	44.9 [13.16] 25.1 [7.36] 3.4	43.2 [12.66] 33.1 [9.70] 3.4	42.5 [12.46] 31.6 [9.26] 3.4	41.7 [12.22] 30.1 [8.82] 3.3	41.6 [12.19] 36.2 [10.61] 3.4	40.8 [11.96] 34.6 [10.14] 3.4	40.1 [11.75] 33.0 [9.67] 3.3
	105 [40.6]	Total BTUH [kW] Sens BTUH [kW] Power	45.3 [13.28] 26.9 [7.88] 3.6	44.4 [13.01] 25.7 [7.53] 3.5	43.6 [12.78] 24.5 [7.18] 3.5	41.9 [12.28] 32.3 [9.47] 3.6	41.2 [12.07] 30.9 [9.06] 3.5	40.4 [11.84] 29.4 [8.62] 3.5	40.2 [11.78] 35.5 [10.40] 3.6	39.5 [11.58] 33.9 [9.94] 3.5	38.8 [11.37] 32.3 [9.47] 3.5
	110 [43.3]	Total BTUH [kW] Sens BTUH [kW] Power	43.9 [12.87] 26.1 [7.65] 3.7	43.1 [12.63] 24.9 [7.30] 3.7	42.3 [12.40] 23.7 [6.95] 3.7	40.5 [11.87] 31.5 [9.23] 3.7	39.8 [11.66] 30.1 [8.82] 3.7	39.1 [11.46] 28.7 [8.41] 3.7	38.8 [11.37] 34.7 [10.17] 3.7	38.2 [11.20] 33.1 [9.70] 3.7	37.5 [10.99] 31.6 [9.26] 3.7
	115 [46.1]	Total BTUH [kW] Sens BTUH [kW] Power	42.4 [12.43] 25.2 [7.39] 3.9	41.7 [12.22] 24.1 [7.06] 3.9	40.9 [11.99] 23.0 [6.74] 3.8	39.1 [11.46] 30.7 [9.00] 3.9	38.4 [11.25] 29.3 [8.59] 3.8	37.7 [11.05] 28.0 [8.21] 3.8	37.4 [10.96] 33.8 [9.91] 3.9	36.7 [10.76] 32.3 [9.47] 3.8	36.1 [10.58] 30.8 [9.03] 3.8

DR —Depression ratio
dbE—Entering air dry bulb
wbE—Entering air wet bulb

Total —Total capacity x 1000 BTUH
Sens —Sensible capacity x 1000 BTUH
Power—KW input

NOTES: ① When the entering air dry bulb is other than 80°F [27°C], adjust the sensible capacity from the table by adding $[1.10 \times \text{CFM} \times (1 - \text{DR}) \times (\text{dbE} - 80)]$.

[] Designates Metric Conversions

SYSTEMS PERFORMANCE—RSNL- SERIES



GROSS SYSTEMS PERFORMANCE DATA—B048

		ENTERING INDOOR AIR @ 80°F [26.7°C] dbE ①									
wbE		71°F [21.7°C]			67°F [19.4°C]			63°F [17.2°C]			
CFM [L/s]		1760 [831]	1600 [755]	1440 [680]	1760 [831]	1600 [755]	1440 [680]	1760 [831]	1600 [755]	1440 [680]	
DR ①		.22	.20	.19	.22	.20	.19	.22	.20	.19	
OUTDOOR DRY BULB TEMPERATURE °F [°C]	75 [23.9]	Total BTUH [kW] Sens BTUH [kW] Power	61.6 [18.05] 34.8 [10.20] 3.0	60.5 [17.73] 33.2 [9.73] 2.9	59.4 [17.41] 31.7 [9.29] 2.9	58.0 [17.00] 41.6 [12.19] 2.9	57.0 [16.71] 39.7 [11.63] 2.9	55.9 [16.38] 37.9 [11.11] 2.9	55.3 [16.21] 44.4 [13.01] 2.9	54.3 [15.91] 42.4 [12.43] 2.9	53.3 [15.62] 40.4 [11.84] 2.9
	80 [26.7]	Total BTUH [kW] Sens BTUH [kW] Power	59.9 [17.55] 33.7 [9.88] 3.1	58.8 [17.23] 32.2 [9.44] 3.1	57.7 [16.91] 30.7 [9.00] 3.1	56.2 [16.47] 40.5 [11.87] 3.1	55.2 [16.18] 38.7 [11.34] 3.1	54.2 [15.88] 36.9 [10.81] 3.1	53.5 [15.68] 43.3 [12.69] 3.1	52.6 [15.42] 41.4 [12.13] 3.1	51.6 [15.12] 39.4 [11.55] 3.1
	85 [29.4]	Total BTUH [kW] Sens BTUH [kW] Power	58.2 [17.06] 32.8 [9.61] 3.3	57.1 [16.73] 31.3 [9.17] 3.3	56.1 [16.44] 29.8 [8.73] 3.3	54.5 [15.97] 39.6 [11.61] 3.3	53.5 [15.68] 37.8 [11.08] 3.3	52.6 [15.42] 36.0 [10.55] 3.2	51.8 [15.18] 42.3 [12.40] 3.3	50.9 [14.92] 40.4 [11.84] 3.3	49.9 [14.62] 38.6 [11.31] 3.2
	90 [32.2]	Total BTUH [kW] Sens BTUH [kW] Power	56.4 [16.53] 31.9 [9.35] 3.5	55.4 [16.24] 30.4 [8.91] 3.5	54.4 [15.94] 29.0 [8.50] 3.4	52.8 [15.47] 38.7 [11.34] 3.5	51.8 [15.18] 36.9 [10.81] 3.4	50.9 [14.92] 35.2 [10.32] 3.4	50.1 [14.68] 41.4 [12.13] 3.5	49.2 [14.42] 39.6 [11.61] 3.4	48.3 [14.16] 37.7 [11.05] 3.4
	95 [35]	Total BTUH [kW] Sens BTUH [kW] Power	54.7 [16.03] 31.0 [9.09] 3.7	53.7 [15.74] 29.6 [8.67] 3.6	52.7 [15.44] 28.2 [8.26] 3.6	51.0 [14.95] 37.8 [11.08] 3.7	50.1 [14.68] 36.1 [10.58] 3.6	49.2 [14.42] 34.4 [10.08] 3.6	48.3 [14.16] 40.6 [11.90] 3.6	47.4 [13.89] 38.7 [11.34] 3.6	46.6 [13.66] 36.9 [10.81] 3.6
	100 [37.8]	Total BTUH [kW] Sens BTUH [kW] Power	52.9 [15.50] 30.1 [8.82] 3.9	51.9 [15.21] 28.8 [8.44] 3.8	51.0 [14.95] 27.4 [8.03] 3.8	49.2 [14.42] 36.9 [10.81] 3.8	48.3 [14.16] 35.3 [10.35] 3.8	47.5 [13.92] 33.6 [9.85] 3.8	46.5 [13.63] 39.7 [11.63] 3.8	45.7 [13.39] 37.9 [11.11] 3.8	44.8 [13.13] 36.1 [10.58] 3.8
	105 [40.6]	Total BTUH [kW] Sens BTUH [kW] Power	51.0 [14.95] 29.2 [8.56] 4.0	50.1 [14.68] 27.9 [8.18] 4.0	49.2 [14.42] 26.6 [7.80] 4.0	47.3 [13.86] 36.0 [10.55] 4.0	46.5 [13.63] 34.4 [10.08] 4.0	45.6 [13.36] 32.8 [9.61] 3.9	44.6 [13.07] 38.8 [11.37] 4.0	43.8 [12.84] 37.0 [10.84] 4.0	43.0 [12.60] 35.3 [10.35] 3.9
	110 [43.3]	Total BTUH [kW] Sens BTUH [kW] Power	49.0 [14.36] 28.2 [8.26] 4.2	48.1 [14.10] 27.0 [7.91] 4.2	47.2 [13.83] 25.7 [7.53] 4.1	45.3 [13.28] 35.0 [10.26] 4.2	44.5 [13.04] 33.5 [9.82] 4.2	43.7 [12.81] 31.9 [9.35] 4.1	42.6 [12.48] 37.8 [11.08] 4.2	41.9 [12.28] 36.1 [10.58] 4.1	41.1 [12.05] 34.4 [10.08] 4.1
	115 [46.1]	Total BTUH [kW] Sens BTUH [kW] Power	46.9 [13.75] 27.1 [7.94] 4.4	46.1 [13.51] 25.9 [7.59] 4.4	45.2 [13.25] 24.7 [7.24] 4.3	43.2 [12.66] 33.9 [9.94] 4.4	42.5 [12.46] 32.4 [9.50] 4.3	41.7 [12.22] 30.9 [9.06] 4.3	40.5 [11.87] 36.7 [10.76] 4.4	39.8 [11.66] 35.1 [10.29] 4.3	39.1 [11.46] 33.4 [9.79] 4.3

GROSS SYSTEMS PERFORMANCE DATA—C060

		ENTERING INDOOR AIR @ 80°F [26.7°C] dbE ①									
wbE		71°F [21.7°C]			67°F [19.4°C]			63°F [17.2°C]			
CFM [L/s]		2040 [963]	1850 [873]	1660 [783]	2040 [963]	1850 [873]	1660 [783]	2040 [963]	1850 [873]	1660 [783]	
DR ①		.21	.20	.18	.21	.20	.18	.21	.20	.18	
OUTDOOR DRY BULB TEMPERATURE °F [°C]	75 [23.9]	Total BTUH [kW] Sens BTUH [kW] Power	73.6 [21.57] 42.2 [12.37] 4.0	72.3 [21.19] 40.3 [11.81] 3.9	71.0 [20.81] 38.4 [11.25] 3.9	68.5 [20.08] 49.1 [14.39] 3.9	67.3 [19.72] 46.9 [13.75] 3.8	66.1 [19.37] 44.7 [13.10] 3.8	65.9 [19.31] 53.3 [15.62] 3.8	64.7 [18.96] 50.9 [14.92] 3.8	63.5 [18.61] 48.5 [14.21] 3.7
	80 [26.7]	Total BTUH [kW] Sens BTUH [kW] Power	71.3 [20.90] 40.7 [11.93] 4.2	70.0 [20.51] 38.9 [11.40] 4.1	68.7 [20.13] 37.1 [10.87] 4.1	66.2 [19.40] 47.7 [13.98] 4.1	65.0 [19.05] 45.5 [13.33] 4.0	63.9 [18.73] 43.4 [12.72] 4.0	63.6 [18.64] 51.8 [15.18] 4.0	62.4 [18.29] 49.5 [14.51] 4.0	61.3 [17.97] 47.2 [13.83] 3.9
	85 [29.4]	Total BTUH [kW] Sens BTUH [kW] Power	69.3 [20.31] 39.5 [11.58] 4.4	68.1 [19.96] 37.8 [11.08] 4.4	66.8 [19.58] 36.0 [10.55] 4.3	64.2 [18.82] 46.5 [13.63] 4.3	63.1 [18.49] 44.4 [13.01] 4.3	61.9 [18.14] 42.3 [12.40] 4.2	61.6 [18.05] 50.6 [14.83] 4.2	60.5 [17.73] 48.3 [14.16] 4.2	59.4 [17.41] 46.1 [13.51] 4.1
	90 [32.2]	Total BTUH [kW] Sens BTUH [kW] Power	67.5 [19.78] 38.5 [11.28] 4.6	66.3 [19.43] 36.8 [10.79] 4.6	65.1 [19.08] 35.1 [10.29] 4.5	62.5 [18.32] 45.5 [13.33] 4.5	61.3 [17.97] 43.5 [12.75] 4.5	60.2 [17.64] 41.4 [12.13] 4.4	59.8 [17.53] 49.6 [14.54] 4.4	58.7 [17.20] 47.4 [13.89] 4.4	57.6 [16.88] 45.2 [13.25] 4.4
	95 [35]	Total BTUH [kW] Sens BTUH [kW] Power	65.8 [19.28] 37.7 [11.05] 4.8	64.7 [18.96] 36.0 [10.55] 4.8	63.5 [18.61] 34.3 [10.05] 4.7	60.8 [17.82] 44.6 [13.07] 4.7	59.7 [17.50] 42.6 [12.48] 4.7	58.6 [17.17] 40.7 [11.93] 4.6	58.1 [17.03] 48.8 [14.30] 4.6	57.1 [16.73] 46.6 [13.66] 4.6	56.0 [16.41] 44.4 [13.01] 4.6
	100 [37.8]	Total BTUH [kW] Sens BTUH [kW] Power	64.2 [18.82] 36.9 [10.81] 5.0	63.0 [18.46] 35.3 [10.35] 5.0	61.9 [18.14] 33.6 [9.85] 4.9	59.1 [17.32] 43.9 [12.87] 4.9	58.0 [17.00] 41.9 [12.28] 4.9	57.0 [16.71] 39.9 [11.69] 4.8	56.4 [16.53] 48.0 [14.07] 4.9	55.4 [16.24] 45.8 [13.42] 4.8	54.4 [15.94] 43.7 [12.81] 4.8
	105 [40.6]	Total BTUH [kW] Sens BTUH [kW] Power	62.4 [18.29] 36.1 [10.58] 5.2	61.3 [17.97] 34.5 [10.11] 5.2	60.1 [17.61] 32.9 [9.64] 5.2	57.3 [16.79] 43.1 [12.63] 5.1	56.3 [16.50] 41.2 [12.07] 5.1	55.3 [16.21] 39.2 [11.49] 5.1	54.6 [16.00] 47.2 [13.83] 5.1	53.7 [15.74] 45.1 [13.22] 5.0	52.7 [15.44] 43.0 [12.60] 5.0
	110 [43.3]	Total BTUH [kW] Sens BTUH [kW] Power	60.4 [17.70] 35.3 [10.35] 5.5	59.3 [17.38] 33.7 [9.88] 5.4	58.2 [17.06] 32.2 [9.44] 5.4	55.3 [16.21] 42.3 [12.40] 5.4	54.3 [15.91] 40.4 [11.84] 5.3	53.4 [15.65] 38.5 [11.28] 5.3	52.7 [15.44] 46.4 [13.60] 5.3	51.7 [15.15] 44.3 [12.98] 5.2	50.8 [14.89] 42.2 [12.37] 5.2
	115 [46.1]	Total BTUH [kW] Sens BTUH [kW] Power	58.1 [17.03] 34.4 [10.08] 5.7	57.1 [16.73] 32.8 [9.61] 5.6	56.0 [16.41] 31.3 [9.17] 5.6	53.0 [15.53] 41.3 [12.10] 5.6	52.1 [15.27] 39.5 [11.58] 5.5	51.1 [14.98] 37.6 [11.02] 5.5	50.4 [14.77] 45.4 [13.31] 5.5	49.5 [14.51] 43.4 [12.72] 5.4	48.6 [14.24] 41.4 [12.13] 5.4

DR —Depression ratio
dbE—Entering air dry bulb
wbE—Entering air wet bulb

Total —Total capacity x 1000 BTUH
Sens —Sensible capacity x 1000 BTUH
Power—KW input

NOTES: ① When the entering air dry bulb is other than 80°F [27°C], adjust the sensible capacity from the table by adding $[1.10 \times \text{CFM} \times (1 - \text{DR}) \times (\text{dbE} - 80)]$.

[] Designates Metric Conversions



SYSTEMS PERFORMANCE—RSPL- SERIES

GROSS SYSTEMS PERFORMANCE DATA—B024

		ENTERING INDOOR AIR @ 80°F [26.7°C] dbE ①									
wbE		71°F [21.7°C]			67°F [19.4°C]			63°F [17.2°C]			
CFM [L/s]		880 [415]	800 [378]	720 [340]	880 [415]	800 [378]	720 [340]	880 [415]	800 [378]	720 [340]	
DR ①		.19	.17	.15	.19	.17	.15	.19	.17	.15	
OUTDOOR DRY BULB TEMPERATURE °F [°C]	75 [23.9]	Total BTUH [kW] Sens BTUH [kW] Power	29.6 [8.67] 17.6 [5.16] 1.5	29.1 [8.53] 16.8 [4.92] 1.5	28.5 [8.35] 16.0 [4.69] 1.5	27.8 [8.15] 20.7 [6.07] 1.5	27.3 [8.00] 19.8 [5.80] 1.5	26.8 [7.85] 18.9 [5.54] 1.5	26.6 [7.80] 22.2 [6.51] 1.5	26.1 [7.65] 21.2 [6.21] 1.5	25.6 [7.50] 20.2 [5.92] 1.5
	80 [26.7]	Total BTUH [kW] Sens BTUH [kW] Power	29.0 [8.50] 17.3 [5.07] 1.6	28.5 [8.35] 16.5 [4.84] 1.6	28.0 [8.21] 15.7 [4.60] 1.6	27.2 [7.97] 20.4 [5.98] 1.6	26.7 [7.83] 19.5 [5.71] 1.6	26.3 [7.71] 18.5 [5.42] 1.6	26.0 [7.62] 21.9 [6.42] 1.6	25.5 [7.47] 20.9 [6.13] 1.6	25.1 [7.36] 19.9 [5.83] 1.6
	85 [29.4]	Total BTUH [kW] Sens BTUH [kW] Power	28.3 [8.29] 16.8 [4.92] 1.7	27.8 [8.15] 16.1 [4.72] 1.7	27.3 [8.00] 15.3 [4.48] 1.7	26.5 [7.77] 19.9 [5.83] 1.7	26.0 [7.62] 19.1 [5.60] 1.7	25.6 [7.50] 18.2 [5.33] 1.7	25.3 [7.41] 21.4 [6.27] 1.7	24.8 [7.27] 20.5 [6.01] 1.7	24.4 [7.15] 19.5 [5.71] 1.7
	90 [32.2]	Total BTUH [kW] Sens BTUH [kW] Power	27.5 [8.06] 16.4 [4.81] 1.8	27.0 [7.91] 15.6 [4.57] 1.8	26.5 [7.77] 14.9 [4.37] 1.8	25.7 [7.53] 19.5 [5.71] 1.8	25.2 [7.39] 18.6 [5.45] 1.8	24.8 [7.27] 17.7 [5.19] 1.8	24.5 [7.18] 21.0 [6.15] 1.8	24.0 [7.03] 20.0 [5.86] 1.8	23.6 [6.92] 19.1 [5.60] 1.8
	95 [35]	Total BTUH [kW] Sens BTUH [kW] Power	26.6 [7.80] 15.9 [4.66] 1.9	26.1 [7.65] 15.2 [4.45] 1.9	25.7 [7.53] 14.5 [4.25] 1.9	24.8 [7.27] 19.0 [5.57] 1.9	24.4 [7.15] 18.2 [5.33] 1.9	23.9 [7.00] 17.3 [5.07] 1.9	23.6 [6.92] 20.5 [6.01] 1.9	23.2 [6.80] 19.6 [5.74] 1.9	22.8 [6.68] 18.7 [5.48] 1.9
	100 [37.8]	Total BTUH [kW] Sens BTUH [kW] Power	25.7 [7.53] 15.5 [4.54] 2.0	25.2 [7.39] 14.8 [4.34] 2.0	24.8 [7.27] 14.1 [4.13] 2.0	23.9 [7.00] 18.6 [5.45] 2.0	23.5 [6.89] 17.7 [5.19] 2.0	23.1 [6.77] 16.9 [4.95] 2.0	22.7 [6.65] 20.1 [5.89] 2.0	22.3 [6.54] 19.2 [5.63] 2.0	21.9 [6.42] 18.3 [5.36] 2.0
	105 [40.6]	Total BTUH [kW] Sens BTUH [kW] Power	24.8 [7.27] 15.1 [4.43] 2.1	24.4 [7.15] 14.4 [4.22] 2.1	23.9 [7.00] 13.7 [4.02] 2.1	23.0 [6.74] 18.2 [5.33] 2.1	22.6 [6.62] 17.4 [5.10] 2.1	22.2 [6.51] 16.6 [4.86] 2.1	21.8 [6.39] 19.7 [5.77] 2.1	21.4 [6.27] 18.8 [5.51] 2.1	21.0 [6.15] 17.9 [5.25] 2.1
	110 [43.3]	Total BTUH [kW] Sens BTUH [kW] Power	24.0 [7.03] 14.8 [4.34] 2.2	23.5 [6.89] 14.2 [4.16] 2.2	23.1 [6.77] 13.5 [3.96] 2.2	22.2 [6.51] 17.9 [5.25] 2.2	21.8 [6.39] 17.1 [5.01] 2.2	21.4 [6.27] 16.3 [4.78] 2.2	21.0 [6.15] 19.4 [5.69] 2.2	20.6 [6.04] 18.6 [5.45] 2.2	20.2 [5.92] 17.7 [5.19] 2.2
	115 [46.1]	Total BTUH [kW] Sens BTUH [kW] Power	23.2 [6.80] 14.7 [4.31] 2.3	22.8 [6.68] 14.0 [4.10] 2.3	22.4 [6.56] 13.4 [3.93] 2.2	21.4 [6.27] 17.8 [5.22] 2.3	21.0 [6.15] 17.0 [4.98] 2.3	20.7 [6.07] 16.2 [4.75] 2.2	20.2 [5.92] 19.3 [5.66] 2.3	19.8 [5.80] 18.4 [5.39] 2.3	19.5 [5.71] 17.6 [5.16] 2.2

GROSS SYSTEMS PERFORMANCE DATA—B030

		ENTERING INDOOR AIR @ 80°F [26.7°C] dbE ①									
wbE		71°F [21.7°C]			67°F [19.4°C]			63°F [17.2°C]			
CFM [L/s]		1100 [519]	1000 [472]	900 [425]	1100 [519]	1000 [472]	900 [425]	1100 [519]	1000 [472]	900 [425]	
DR ①		.20	.19	.17	.20	.19	.17	.20	.19	.17	
OUTDOOR DRY BULB TEMPERATURE °F [°C]	75 [23.9]	Total BTUH [kW] Sens BTUH [kW] Power	36.7 [10.76] 21.5 [6.30] 1.8	36.1 [10.58] 20.6 [6.04] 1.8	35.4 [10.37] 19.6 [5.74] 1.8	34.5 [10.11] 25.7 [7.53] 1.8	33.9 [9.94] 24.6 [7.21] 1.8	33.3 [9.76] 23.4 [6.86] 1.8	33.1 [9.70] 27.4 [8.03] 1.8	32.5 [9.52] 26.2 [7.68] 1.8	32.0 [9.38] 25.0 [7.33] 1.8
	80 [26.7]	Total BTUH [kW] Sens BTUH [kW] Power	35.8 [10.49] 20.9 [6.13] 1.9	35.2 [10.32] 20.0 [5.86] 1.9	34.5 [10.11] 19.0 [5.57] 1.9	33.6 [9.85] 25.1 [7.36] 1.9	33.0 [9.67] 24.0 [7.03] 1.9	32.4 [9.50] 22.9 [6.71] 1.9	32.2 [9.44] 26.8 [7.85] 1.9	31.6 [9.26] 25.6 [7.50] 1.9	31.1 [9.11] 24.4 [7.15] 1.9
	85 [29.4]	Total BTUH [kW] Sens BTUH [kW] Power	34.8 [10.20] 20.3 [5.95] 2.0	34.2 [10.02] 19.4 [5.69] 2.0	33.5 [9.82] 18.5 [5.42] 2.0	32.6 [9.55] 24.5 [7.18] 2.0	32.0 [9.38] 23.4 [6.86] 2.0	31.4 [9.20] 22.3 [6.54] 2.0	31.2 [9.14] 26.1 [7.65] 2.0	30.6 [8.97] 25.0 [7.33] 2.0	30.1 [8.82] 23.8 [6.98] 2.0
	90 [32.2]	Total BTUH [kW] Sens BTUH [kW] Power	33.7 [9.88] 19.7 [5.77] 2.1	33.1 [9.70] 18.8 [5.51] 2.1	32.5 [9.52] 17.9 [5.25] 2.1	31.4 [9.20] 23.8 [6.98] 2.1	30.9 [9.06] 22.8 [6.68] 2.1	30.3 [8.88] 21.7 [6.36] 2.1	30.1 [8.82] 25.5 [7.47] 2.1	29.5 [8.65] 24.4 [7.15] 2.1	29.0 [8.50] 23.3 [6.83] 2.1
	95 [35]	Total BTUH [kW] Sens BTUH [kW] Power	32.4 [9.50] 19.0 [5.57] 2.3	31.9 [9.35] 18.2 [5.33] 2.2	31.3 [9.17] 17.3 [5.07] 2.2	30.2 [8.85] 23.2 [6.80] 2.3	29.7 [8.70] 22.2 [6.51] 2.2	29.1 [8.53] 21.1 [6.18] 2.2	28.9 [8.47] 24.9 [7.30] 2.2	28.3 [8.29] 23.8 [6.98] 2.2	27.8 [8.15] 22.7 [6.65] 2.2
	100 [37.8]	Total BTUH [kW] Sens BTUH [kW] Power	31.2 [9.14] 18.4 [5.39] 2.4	30.6 [8.97] 17.6 [5.16] 2.3	30.1 [8.82] 16.7 [4.89] 2.3	28.9 [8.47] 22.6 [6.62] 2.4	28.4 [8.32] 21.6 [6.33] 2.3	27.9 [8.18] 20.5 [6.01] 2.3	27.6 [8.09] 24.2 [7.09] 2.4	27.1 [7.94] 23.2 [6.80] 2.3	26.6 [7.80] 22.1 [6.48] 2.3
	105 [40.6]	Total BTUH [kW] Sens BTUH [kW] Power	29.8 [8.73] 17.7 [5.19] 2.5	29.3 [8.59] 16.9 [4.95] 2.5	28.8 [8.44] 16.1 [4.72] 2.4	27.6 [8.09] 21.9 [6.42] 2.5	27.1 [7.94] 20.9 [6.13] 2.5	26.6 [7.80] 19.9 [5.83] 2.4	26.2 [7.68] 23.5 [6.89] 2.5	25.8 [7.56] 22.5 [6.59] 2.4	25.3 [7.41] 21.4 [6.27] 2.4
	110 [43.3]	Total BTUH [kW] Sens BTUH [kW] Power	28.5 [8.35] 16.9 [4.95] 2.6	27.9 [8.18] 16.2 [4.75] 2.6	27.4 [8.03] 15.4 [4.51] 2.5	26.2 [7.68] 21.1 [6.18] 2.6	25.8 [7.56] 20.2 [5.92] 2.6	25.3 [7.41] 19.2 [5.63] 2.5	24.9 [7.30] 22.8 [6.68] 2.6	24.4 [7.15] 21.8 [6.39] 2.6	24.0 [7.03] 20.8 [6.10] 2.5
	115 [46.1]	Total BTUH [kW] Sens BTUH [kW] Power	27.1 [7.94] 16.2 [4.75] 2.7	26.6 [7.80] 15.4 [4.51] 2.7	26.1 [7.65] 14.7 [4.31] 2.6	24.8 [7.27] 20.3 [5.95] 2.7	24.4 [7.15] 19.4 [5.69] 2.7	23.9 [7.00] 18.5 [5.42] 2.6	23.5 [6.89] 22.0 [6.45] 2.7	23.0 [6.74] 21.0 [6.15] 2.7	22.6 [6.62] 20.1 [5.89] 2.6

DR —Depression ratio
dbE—Entering air dry bulb
wbE—Entering air wet bulb

Total —Total capacity x 1000 BTUH
Sens —Sensible capacity x 1000 BTUH
Power—kW input

NOTES: ① When the entering air dry bulb is other than 80°F [27°C], adjust the sensible capacity from the table by adding [1.10 x CFM x (1 - DR) x (dbE - 80)].

[] Designates Metric Conversions

SYSTEMS PERFORMANCE—RSPL- SERIES



GROSS SYSTEMS PERFORMANCE DATA—B036

		ENTERING INDOOR AIR @ 80°F [26.7°C] dbE ①									
		wbE	71°F [21.7°C]			67°F [19.4°C]			63°F [17.2°C]		
		CFM [L/s]	1320 [623]	1200 [566]	1080 [510]	1320 [623]	1200 [566]	1080 [510]	1320 [623]	1200 [566]	1080 [510]
		DR ①	.19	.18	.16	.19	.18	.16	.19	.18	.16
OUTDOOR DRY BULB TEMPERATURE °F [°C]	75 [23.9]	Total BTUH [kW]	44.7 [13.10]	43.9 [12.87]	43.1 [12.63]	42.1 [12.34]	41.3 [12.10]	40.6 [11.90]	40.4 [11.84]	39.7 [11.63]	39.0 [11.43]
		Sens BTUH [kW]	25.8 [7.56]	24.7 [7.24]	23.5 [6.89]	31.0 [9.09]	29.6 [8.67]	28.2 [8.26]	32.9 [9.64]	31.5 [9.23]	30.0 [8.79]
		Power	2.2	2.2	2.2	2.2	2.2	2.2	2.2	2.2	2.1
	80 [26.7]	Total BTUH [kW]	44.0 [12.90]	43.3 [12.69]	42.5 [12.46]	41.4 [12.13]	40.6 [11.90]	39.9 [11.69]	39.7 [11.63]	39.0 [11.43]	38.3 [11.22]
		Sens BTUH [kW]	25.5 [7.47]	24.3 [7.12]	23.2 [6.80]	30.7 [9.00]	29.3 [8.59]	27.9 [8.18]	32.6 [9.55]	31.1 [9.11]	29.7 [8.70]
		Power	2.3	2.3	2.3	2.3	2.3	2.3	2.3	2.3	2.3
	85 [29.4]	Total BTUH [kW]	43.0 [12.60]	42.2 [12.37]	41.4 [12.13]	40.3 [11.81]	39.6 [11.61]	38.9 [11.40]	38.6 [11.31]	38.0 [11.14]	37.3 [10.93]
		Sens BTUH [kW]	24.9 [7.30]	23.8 [6.98]	22.7 [6.65]	30.1 [8.82]	28.7 [8.41]	27.4 [8.03]	32.0 [9.38]	30.6 [8.97]	29.1 [8.53]
		Power	2.5	2.5	2.4	2.5	2.4	2.4	2.5	2.4	2.4
	90 [32.2]	Total BTUH [kW]	41.6 [12.19]	40.9 [11.99]	40.1 [11.75]	39.0 [11.43]	38.3 [11.22]	37.6 [11.02]	37.3 [10.93]	36.6 [10.73]	36.0 [10.55]
Sens BTUH [kW]		24.1 [7.06]	23.1 [6.77]	22.0 [6.45]	29.3 [8.59]	28.0 [8.21]	26.7 [7.83]	31.2 [9.14]	29.9 [8.76]	28.5 [8.35]	
Power		2.6	2.6	2.6	2.6	2.6	2.6	2.6	2.6	2.5	
95 [35]	Total BTUH [kW]	40.1 [11.75]	39.4 [11.55]	38.7 [11.34]	37.5 [10.99]	36.8 [10.79]	36.1 [10.58]	35.8 [10.49]	35.2 [10.32]	34.5 [10.11]	
	Sens BTUH [kW]	23.3 [6.83]	22.3 [6.54]	21.2 [6.21]	28.5 [8.35]	27.2 [7.97]	25.9 [7.59]	30.4 [8.91]	29.1 [8.53]	27.7 [8.12]	
	Power	2.7	2.7	2.7	2.7	2.7	2.7	2.7	2.7	2.7	
100 [37.8]	Total BTUH [kW]	38.5 [11.28]	37.8 [11.08]	37.1 [10.87]	35.9 [10.52]	35.2 [10.32]	34.6 [10.14]	34.2 [10.02]	33.6 [9.85]	33.0 [9.67]	
	Sens BTUH [kW]	22.4 [6.56]	21.4 [6.27]	20.4 [5.98]	27.6 [8.09]	26.4 [7.74]	25.2 [7.39]	29.6 [8.67]	28.2 [8.26]	26.9 [7.88]	
	Power	2.9	2.9	2.8	2.9	2.8	2.8	2.9	2.8	2.8	
105 [40.6]	Total BTUH [kW]	36.9 [10.81]	36.3 [10.64]	35.6 [10.43]	34.3 [10.05]	33.7 [9.88]	33.0 [9.67]	32.6 [9.55]	32.0 [9.38]	31.4 [9.20]	
	Sens BTUH [kW]	21.6 [6.33]	20.7 [6.07]	19.7 [5.77]	26.8 [7.85]	25.6 [7.50]	24.4 [7.15]	28.8 [8.44]	27.5 [8.06]	26.2 [7.68]	
	Power	3.0	3.0	3.0	3.0	3.0	3.0	3.0	3.0	2.9	
110 [43.3]	Total BTUH [kW]	35.5 [10.40]	34.8 [10.20]	34.2 [10.02]	32.8 [9.61]	32.2 [9.44]	31.6 [9.26]	31.1 [9.11]	30.6 [8.97]	30.0 [8.79]	
	Sens BTUH [kW]	21.0 [6.15]	20.1 [5.89]	19.1 [5.60]	26.2 [7.68]	25.0 [7.33]	23.8 [6.98]	28.1 [8.24]	26.9 [7.88]	25.6 [7.50]	
	Power	3.2	3.1	3.1	3.1	3.1	3.1	3.1	3.1	3.1	
115 [46.1]	Total BTUH [kW]	34.2 [10.02]	33.6 [9.85]	33.0 [9.67]	31.5 [9.23]	31.0 [9.09]	30.4 [8.91]	29.9 [8.76]	29.3 [8.59]	28.8 [8.44]	
	Sens BTUH [kW]	20.6 [6.04]	19.6 [5.74]	18.7 [5.48]	25.7 [7.53]	24.6 [7.21]	23.4 [6.86]	27.7 [8.12]	26.4 [7.74]	25.2 [7.39]	
	Power	3.3	3.3	3.2	3.3	3.2	3.2	3.3	3.2	3.2	

GROSS SYSTEMS PERFORMANCE DATA—B042

		ENTERING INDOOR AIR @ 80°F [26.7°C] dbE ①									
		wbE	71°F [21.7°C]			67°F [19.4°C]			63°F [17.2°C]		
		CFM [L/s]	1540 [727]	1400 [661]	1260 [595]	1540 [727]	1400 [661]	1260 [595]	1540 [727]	1400 [661]	1260 [595]
		DR ①	.19	.17	.16	.19	.17	.16	.19	.17	.16
OUTDOOR DRY BULB TEMPERATURE °F [°C]	75 [23.9]	Total BTUH [kW]	54.0 [15.83]	53.0 [15.53]	52.1 [15.27]	50.6 [14.83]	49.7 [14.57]	48.8 [14.30]	48.9 [14.33]	48.0 [14.07]	47.2 [13.83]
		Sens BTUH [kW]	31.1 [9.11]	29.7 [8.70]	28.3 [8.29]	36.6 [10.73]	35.0 [10.26]	33.4 [9.79]	39.8 [11.66]	38.1 [11.17]	36.3 [10.64]
		Power	2.7	2.7	2.6	2.7	2.6	2.6	2.7	2.6	2.6
	80 [26.7]	Total BTUH [kW]	52.4 [15.36]	51.5 [15.09]	50.6 [14.83]	49.0 [14.36]	48.2 [14.13]	47.3 [13.86]	47.3 [13.86]	46.5 [13.63]	45.7 [13.39]
		Sens BTUH [kW]	30.4 [8.91]	29.0 [8.50]	27.7 [8.12]	35.9 [10.52]	34.3 [10.05]	32.7 [9.58]	39.1 [11.46]	37.4 [10.96]	35.6 [10.43]
		Power	2.8	2.8	2.8	2.8	2.8	2.8	2.8	2.8	2.8
	85 [29.4]	Total BTUH [kW]	51.0 [14.95]	50.1 [14.68]	49.2 [14.42]	47.6 [13.95]	46.7 [13.69]	45.9 [13.45]	45.9 [13.45]	45.1 [13.22]	44.2 [12.95]
		Sens BTUH [kW]	29.7 [8.70]	28.3 [8.29]	27.0 [7.91]	35.2 [10.32]	33.6 [9.85]	32.1 [9.41]	38.4 [11.25]	36.7 [10.76]	35.0 [10.26]
		Power	3.0	3.0	2.9	3.0	2.9	2.9	3.0	2.9	2.9
	90 [32.2]	Total BTUH [kW]	49.6 [14.54]	48.7 [14.27]	47.8 [14.01]	46.2 [13.54]	45.4 [13.31]	44.5 [13.04]	44.5 [13.04]	43.7 [12.81]	42.9 [12.57]
Sens BTUH [kW]		29.0 [8.50]	27.7 [8.12]	26.4 [7.74]	34.5 [10.11]	33.0 [9.67]	31.4 [9.20]	37.7 [11.05]	36.0 [10.55]	34.3 [10.05]	
Power		3.1	3.1	3.1	3.1	3.1	3.1	3.1	3.1	3.1	
95 [35]	Total BTUH [kW]	48.2 [14.13]	47.4 [13.89]	46.5 [13.63]	44.8 [13.13]	44.0 [12.90]	43.2 [12.66]	43.1 [12.63]	42.4 [12.43]	41.6 [12.19]	
	Sens BTUH [kW]	28.3 [8.29]	27.0 [7.91]	25.7 [7.53]	33.8 [9.91]	32.3 [9.47]	30.8 [9.03]	37.0 [10.84]	35.3 [10.35]	33.7 [9.88]	
	Power	3.3	3.3	3.2	3.3	3.2	3.2	3.3	3.2	3.2	
100 [37.8]	Total BTUH [kW]	46.9 [13.75]	46.0 [13.48]	45.2 [13.25]	43.5 [12.75]	42.7 [12.51]	41.9 [12.28]	41.8 [12.25]	41.0 [12.02]	40.3 [11.81]	
	Sens BTUH [kW]	27.5 [8.06]	26.3 [7.71]	25.1 [7.36]	33.1 [9.70]	31.6 [9.26]	30.1 [8.82]	36.3 [10.64]	34.7 [10.17]	33.0 [9.67]	
	Power	3.4	3.4	3.4	3.4	3.4	3.4	3.4	3.4	3.4	
105 [40.6]	Total BTUH [kW]	45.5 [13.33]	44.7 [13.10]	43.9 [12.87]	42.1 [12.34]	41.4 [12.13]	40.6 [11.90]	40.4 [11.84]	39.7 [11.63]	39.0 [11.43]	
	Sens BTUH [kW]	26.8 [7.85]	25.6 [7.50]	24.4 [7.15]	32.3 [9.47]	30.9 [9.06]	29.4 [8.62]	35.5 [10.40]	33.9 [9.94]	32.3 [9.47]	
	Power	3.6	3.6	3.5	3.6	3.5	3.5	3.6	3.5	3.5	
110 [43.3]	Total BTUH [kW]	44.1 [12.92]	43.3 [12.69]	42.5 [12.46]	40.7 [11.93]	40.0 [11.72]	39.3 [11.52]	39.0 [11.43]	38.3 [11.22]	37.6 [11.02]	
	Sens BTUH [kW]	26.0 [7.62]	24.8 [7.27]	23.7 [6.95]	31.5 [9.23]	30.1 [8.82]	28.7 [8.41]	34.7 [10.17]	33.2 [9.73]	31.6 [9.26]	
	Power	3.7	3.7	3.7	3.7	3.7	3.7	3.7	3.7	3.7	
115 [46.1]	Total BTUH [kW]	42.7 [12.51]	41.9 [12.28]	41.1 [12.05]	39.3 [11.52]	38.6 [11.31]	37.9 [11.11]	37.6 [11.02]	36.9 [10.81]	36.2 [10.61]	
	Sens BTUH [kW]	25.1 [7.36]	24.0 [7.03]	22.9 [6.71]	30.7 [9.00]	29.3 [8.59]	27.9 [8.18]	33.8 [9.91]	32.3 [9.47]	30.8 [9.03]	
	Power	3.9	3.9	3.8	3.9	3.8	3.8	3.9	3.8	3.8	

DR —Depression ratio
dbE—Entering air dry bulb
wbE—Entering air wet bulb

Total —Total capacity x 1000 BTUH
Sens —Sensible capacity x 1000 BTUH
Power—KW input

NOTES: ① When the entering air dry bulb is other than 80°F [27°C], adjust the sensible capacity from the table by adding [1.10 x CFM x (1 - DR) x (dbE - 80)].

[] Designates Metric Conversions



SYSTEMS PERFORMANCE—RSPL- SERIES

GROSS SYSTEMS PERFORMANCE DATA—B048

		ENTERING INDOOR AIR @ 80°F [26.7°C] dbE ①									
wbE		71°F [21.7°C]			67°F [19.4°C]			63°F [17.2°C]			
CFM [L/s]		1760 [831]	1600 [755]	1440 [680]	1760 [831]	1600 [755]	1440 [680]	1760 [831]	1600 [755]	1440 [680]	
DR ①		.21	.20	.18	.21	.20	.18	.21	.20	.18	
OUTDOOR DRY BULB TEMPERATURE °F [°C]	75 [23.9]	Total BTUH [kW] Sens BTUH [kW] Power	62.0 [18.17] 35.0 [10.26] 3.0	60.9 [17.85] 33.4 [9.79] 3.0	59.8 [17.53] 31.9 [9.35] 3.0	58.3 [17.09] 41.9 [12.28] 3.0	57.3 [16.79] 40.0 [11.72] 3.0	56.3 [16.50] 38.1 [11.17] 2.9	55.6 [16.29] 44.7 [13.10] 3.0	54.6 [16.00] 42.7 [12.51] 3.0	53.6 [15.71] 40.7 [11.93] 2.9
	80 [26.7]	Total BTUH [kW] Sens BTUH [kW] Power	60.3 [17.67] 33.9 [9.94] 3.2	59.2 [17.35] 32.4 [9.50] 3.2	58.1 [17.03] 30.9 [9.06] 3.1	56.6 [16.59] 40.8 [11.96] 3.2	55.5 [16.27] 39.0 [11.43] 3.1	54.5 [15.97] 37.2 [10.90] 3.1	53.8 [15.77] 43.6 [12.78] 3.2	52.8 [15.47] 41.7 [12.22] 3.1	51.9 [15.21] 39.7 [11.63] 3.1
	85 [29.4]	Total BTUH [kW] Sens BTUH [kW] Power	58.5 [17.14] 32.9 [9.64] 3.4	57.5 [16.85] 31.5 [9.23] 3.3	56.4 [16.53] 30.0 [8.79] 3.3	54.8 [16.06] 39.8 [11.66] 3.3	53.8 [15.77] 38.1 [11.17] 3.3	52.8 [15.47] 36.3 [10.64] 3.3	52.0 [15.24] 42.6 [12.48] 3.3	51.1 [14.98] 40.7 [11.93] 3.3	50.2 [14.71] 38.8 [11.37] 3.3
	90 [32.2]	Total BTUH [kW] Sens BTUH [kW] Power	56.7 [16.62] 32.0 [9.38] 3.5	55.7 [16.32] 30.6 [8.97] 3.5	54.7 [16.03] 29.2 [8.56] 3.5	53.0 [15.53] 38.9 [11.40] 3.5	52.1 [15.27] 37.2 [10.90] 3.5	51.1 [14.98] 35.4 [10.37] 3.4	50.3 [14.74] 41.7 [12.22] 3.5	49.4 [14.48] 39.9 [11.69] 3.5	48.5 [14.21] 38.0 [11.14] 3.4
	95 [35]	Total BTUH [kW] Sens BTUH [kW] Power	55.0 [16.12] 31.1 [9.11] 3.7	54.0 [15.83] 29.7 [8.70] 3.7	53.0 [15.53] 28.3 [8.29] 3.6	51.3 [15.03] 38.0 [11.14] 3.7	50.3 [14.74] 36.3 [10.64] 3.6	49.4 [14.48] 34.6 [10.14] 3.6	48.5 [14.21] 40.8 [11.96] 3.7	47.6 [13.95] 39.0 [11.43] 3.6	46.8 [13.72] 37.2 [10.90] 3.6
	100 [37.8]	Total BTUH [kW] Sens BTUH [kW] Power	53.1 [15.56] 30.2 [8.85] 3.9	52.2 [15.30] 28.9 [8.47] 3.8	51.2 [15.01] 27.5 [8.06] 3.8	49.4 [14.48] 37.1 [10.87] 3.8	48.5 [14.21] 35.5 [10.40] 3.8	47.7 [13.98] 33.8 [9.91] 3.8	46.7 [13.69] 40.0 [11.72] 3.8	45.8 [13.42] 38.2 [11.20] 3.8	45.0 [13.19] 36.4 [10.67] 3.8
	105 [40.6]	Total BTUH [kW] Sens BTUH [kW] Power	51.2 [15.01] 29.3 [8.59] 4.0	50.3 [14.74] 28.0 [8.21] 4.0	49.4 [14.48] 26.7 [7.83] 4.0	47.5 [13.92] 36.2 [10.61] 4.0	46.7 [13.69] 34.6 [10.14] 4.0	45.8 [13.42] 33.0 [9.67] 3.9	44.8 [13.13] 39.0 [11.43] 4.0	44.0 [12.90] 37.3 [10.93] 4.0	43.2 [12.66] 35.5 [10.40] 3.9
	110 [43.3]	Total BTUH [kW] Sens BTUH [kW] Power	49.2 [14.42] 28.3 [8.29] 4.2	48.3 [14.16] 27.1 [7.94] 4.2	47.5 [13.92] 25.8 [7.56] 4.1	45.5 [13.33] 35.2 [10.32] 4.2	44.7 [13.10] 33.6 [9.85] 4.1	43.9 [12.87] 32.1 [9.41] 4.1	42.8 [12.54] 38.0 [11.14] 4.2	42.0 [12.31] 36.3 [10.64] 4.1	41.2 [12.07] 34.6 [10.14] 4.1
	115 [46.1]	Total BTUH [kW] Sens BTUH [kW] Power	47.1 [13.80] 27.2 [7.97] 4.4	46.2 [13.54] 26.0 [7.62] 4.3	45.4 [13.31] 24.8 [7.27] 4.3	43.4 [12.72] 34.1 [9.99] 4.3	42.6 [12.48] 32.6 [9.55] 4.3	41.8 [12.25] 31.1 [9.11] 4.3	40.6 [11.90] 36.9 [10.81] 4.3	39.9 [11.69] 35.3 [10.35] 4.3	39.2 [11.49] 33.6 [9.85] 4.3

GROSS SYSTEMS PERFORMANCE DATA—B060

		ENTERING INDOOR AIR @ 80°F [26.7°C] dbE ①									
wbE		71°F [21.7°C]			67°F [19.4°C]			63°F [17.2°C]			
CFM [L/s]		2040 [963]	1850 [873]	1660 [783]	2040 [963]	1850 [873]	1660 [783]	2040 [963]	1850 [873]	1660 [783]	
DR ①		.21	.20	.18	.21	.20	.18	.21	.20	.18	
OUTDOOR DRY BULB TEMPERATURE °F [°C]	75 [23.9]	Total BTUH [kW] Sens BTUH [kW] Power	73.6 [21.57] 42.2 [12.37] 4.0	72.3 [21.19] 40.3 [11.81] 3.9	71.0 [20.81] 38.4 [11.25] 3.9	68.5 [20.08] 49.1 [14.39] 3.9	67.3 [19.72] 46.9 [13.75] 3.8	66.1 [19.37] 44.7 [13.10] 3.8	65.9 [19.31] 53.3 [15.62] 3.8	64.7 [18.96] 50.9 [14.92] 3.8	63.5 [18.61] 48.5 [14.21] 3.7
	80 [26.7]	Total BTUH [kW] Sens BTUH [kW] Power	71.3 [20.90] 40.7 [11.93] 4.2	70.0 [20.51] 38.9 [11.40] 4.1	68.7 [20.13] 37.1 [10.87] 4.1	66.2 [19.40] 47.7 [13.98] 4.1	65.0 [19.05] 45.5 [13.33] 4.0	63.9 [18.73] 43.4 [12.72] 4.0	63.6 [18.64] 51.8 [15.18] 4.0	62.4 [18.29] 49.5 [14.51] 4.0	61.3 [17.97] 47.2 [13.83] 3.9
	85 [29.4]	Total BTUH [kW] Sens BTUH [kW] Power	69.3 [20.31] 39.5 [11.58] 4.4	68.1 [19.96] 37.8 [11.08] 4.4	66.8 [19.58] 36.0 [10.55] 4.3	64.2 [18.82] 46.5 [13.63] 4.3	63.1 [18.49] 44.4 [13.01] 4.3	61.9 [18.14] 42.3 [12.40] 4.2	61.6 [18.05] 50.6 [14.83] 4.2	60.5 [17.73] 48.3 [14.16] 4.2	59.4 [17.41] 46.1 [13.51] 4.1
	90 [32.2]	Total BTUH [kW] Sens BTUH [kW] Power	67.5 [19.78] 38.5 [11.28] 4.6	66.3 [19.43] 36.8 [10.79] 4.6	65.1 [19.08] 35.1 [10.29] 4.5	62.5 [18.32] 45.5 [13.33] 4.5	61.3 [17.97] 43.5 [12.75] 4.5	60.2 [17.64] 41.4 [12.13] 4.4	59.8 [17.53] 49.6 [14.54] 4.4	58.7 [17.20] 47.4 [13.89] 4.4	57.6 [16.88] 45.2 [13.25] 4.4
	95 [35]	Total BTUH [kW] Sens BTUH [kW] Power	65.8 [19.28] 37.7 [11.05] 4.8	64.7 [18.96] 36.0 [10.55] 4.8	63.5 [18.61] 34.3 [10.05] 4.7	60.8 [17.82] 44.6 [13.07] 4.7	59.7 [17.50] 42.6 [12.48] 4.7	58.6 [17.17] 40.7 [11.93] 4.6	58.1 [17.03] 48.8 [14.30] 4.6	57.1 [16.73] 46.6 [13.66] 4.6	56.0 [16.41] 44.4 [13.01] 4.6
	100 [37.8]	Total BTUH [kW] Sens BTUH [kW] Power	64.2 [18.82] 36.9 [10.81] 5.0	63.0 [18.46] 35.3 [10.35] 5.0	61.9 [18.14] 33.6 [9.85] 4.9	59.1 [17.32] 43.9 [12.87] 4.9	58.0 [17.00] 41.9 [12.28] 4.9	57.0 [16.71] 39.9 [11.69] 4.8	56.4 [16.53] 48.0 [14.07] 4.9	55.4 [16.24] 45.8 [13.42] 4.8	54.4 [15.94] 43.7 [12.81] 4.8
	105 [40.6]	Total BTUH [kW] Sens BTUH [kW] Power	62.4 [18.29] 36.1 [10.58] 5.2	61.3 [17.97] 34.5 [10.11] 5.2	60.1 [17.61] 32.9 [9.64] 5.2	57.3 [16.79] 43.1 [12.63] 5.1	56.3 [16.50] 41.2 [12.07] 5.1	55.3 [16.21] 39.2 [11.49] 5.1	54.6 [16.00] 47.2 [13.83] 5.1	53.7 [15.74] 45.1 [13.22] 5.0	52.7 [15.44] 43.0 [12.60] 5.0
	110 [43.3]	Total BTUH [kW] Sens BTUH [kW] Power	60.4 [17.70] 35.3 [10.35] 5.5	59.3 [17.38] 33.7 [9.88] 5.4	58.2 [17.06] 32.2 [9.44] 5.4	55.3 [16.21] 42.3 [12.40] 5.4	54.3 [15.91] 40.4 [11.84] 5.3	53.4 [15.65] 38.5 [11.28] 5.3	52.7 [15.44] 46.4 [13.60] 5.3	51.7 [15.15] 44.3 [12.98] 5.2	50.8 [14.89] 42.2 [12.37] 5.2
	115 [46.1]	Total BTUH [kW] Sens BTUH [kW] Power	58.1 [17.03] 34.4 [10.08] 5.7	57.1 [16.73] 32.8 [9.61] 5.6	56.0 [16.41] 31.3 [9.17] 5.6	53.0 [15.53] 41.3 [12.10] 5.6	52.1 [15.27] 39.5 [11.58] 5.5	51.1 [14.98] 37.6 [11.02] 5.5	50.4 [14.77] 45.4 [13.31] 5.5	49.5 [14.51] 43.4 [12.72] 5.4	48.6 [14.24] 41.4 [12.13] 5.4

DR —Depression ratio
dbE—Entering air dry bulb
wbE—Entering air wet bulb

Total —Total capacity x 1000 BTUH
Sens —Sensible capacity x 1000 BTUH
Power—KW input

NOTES: ① When the entering air dry bulb is other than 80°F [27°C], adjust the sensible capacity from the table by adding $[1.10 \times \text{CFM} \times (1 - \text{DR}) \times (\text{dbE} - 80)]$.

[] Designates Metric Conversions



INDOOR AIRFLOW PERFORMANCE—208 VOLTS

Nominal Cooling Capacity Tons [kW]	Motor Speed from Factory		Blower Size/ Motor HP [W] & # of Speeds	Motor Speed	External Static Pressure—Inches W.C. [kPa] Side Discharge—Wet Coil							
	Cool	Heat			0.1 [.02]	0.2 [.05]	0.3 [.07]	0.4 [.10]	0.5 [.12]	0.6 [.15]	0.7 [.17]	
2.0 [7.03]	High	High	9 x 7 Blower 1/4 HP [186 W] 2 Speed (PSC Motor)	Low	CFM [l/s]	675 [319]	657 [310]	634 [299]	602 [284]	560 [264]	505 [238]	435 [205]
					RPM	695	785	870	905	940	980	1020
					Watts	221	214	203	191	171	193	149
2.5 [8.79]	Low	Low	10 x 9 Blower 1/2 HP [372 W] 3 Speed (PSC Motor)	Low	CFM [l/s]	898 [424]	861 [406]	822 [388]	777 [367]	721 [340]	651 [307]	562 [265]
					RPM	940	965	995	1020	1045	1070	1090
					Watts	292	278	266	253	239	221	199
3.0 [10.55]	Med.	Med.	10 x 9 Blower 1/2 HP [372 W] 3 Speed (PSC Motor)	Med.	CFM [l/s]	1076 [508]	1059 [500]	1032 [487]	996 [470]	950 [448]	896 [423]	832 [393]
					RPM	730	775	820	865	905	940	975
					Watts	356	349	341	331	320	305	287
3.5 [12.31]	High	High	10 x 9 Blower 1/2 HP [372 W] 3 Speed (PSC Motor)	High	CFM [l/s]	1222 [577]	1197 [565]	1179 [556]	1162 [548]	1137 [537]	1097 [518]	1033 [488]
					RPM	765	810	855	890	920	960	995
					Watts	423	415	407	397	386	370	351
4.0 [14.07]	Med.	Med.	10 x 9 Blower 3/4 HP [559 W] 3 Speed (PSC Motor)	High	CFM [l/s]	1514 [715]	1461 [670]	1415 [668]	1370 [647]	1322 [624]	1266 [597]	1197 [565]
					RPM	895	930	965	985	1005	1025	1045
					Watts	538	514	493	473	454	434	412
5.0 [17.59]	High (Tap 4)	High (Tap 2)	12 x 9 Blower 1 HP [746 W] 4 Speed (X13 Motor)	High (Tap 2)	CFM [l/s]	1204 [568]	1202 [567]	1191 [562]	1171 [553]	1143 [539]	1107 [522]	1065 [503]
					RPM	734	810	886	923	959	988	1016
					Watts	476	468	450	427	403	380	363
5.0 [17.59]	High (Tap 4)	High (Tap 2)	12 x 9 Blower 1 HP [746 W] 4 Speed (X13 Motor)	High (Tap 2)	CFM [l/s]	1674 [790]	1620 [765]	1566 [739]	1511 [713]	1451 [685]	1384 [653]	1305 [616]
					RPM	997	1019	1040	1058	1076	1088	1100
					Watts	625	596	567	539	512	484	455
5.0 [17.59]	High (Tap 4)	High (Tap 2)	12 x 9 Blower 1 HP [746 W] 4 Speed (X13 Motor)	High (Tap 2)	CFM [l/s]	1843 [870]	1763 [832]	1693 [799]	1627 [768]	1560 [736]	1485 [701]	1398 [660]
					RPM	1085	1094	1102	1110	1118	1126	1134
					Watts	699	663	632	604	576	548	517
5.0 [17.59]	High (Tap 4)	High (Tap 2)	12 x 9 Blower 1 HP [746 W] 4 Speed (X13 Motor)	High (Tap 2)	CFM [l/s]	1310 [618]	1288 [608]	1238 [584]	1204 [568]	1149 [542]	1104 [521]	1035 [488]
					RPM	731	757	789	826	857	894	937
					Watts	218	229	237	250	258	270	280
5.0 [17.59]	High (Tap 4)	High (Tap 2)	12 x 9 Blower 1 HP [746 W] 4 Speed (X13 Motor)	High (Tap 2)	CFM [l/s]	1418 [669]	1386 [654]	1352 [638]	1307 [617]	1270 [599]	1221 [576]	1180 [557]
					RPM	774	794	829	860	892	922	955
					Watts	267	273	287	295	308	316	328
5.0 [17.59]	High (Tap 4)	High (Tap 2)	12 x 9 Blower 1 HP [746 W] 4 Speed (X13 Motor)	High (Tap 2)	CFM [l/s]	1858 [877]	1821 [859]	1782 [841]	1752 [827]	1714 [809]	1678 [792]	1640 [774]
					RPM	944	968	994	1019	1041	1072	1089
					Watts	541	555	564	578	586	598	611
5.0 [17.59]	High (Tap 4)	High (Tap 2)	12 x 9 Blower 1 HP [746 W] 4 Speed (X13 Motor)	High (Tap 2)	CFM [l/s]	2017 [952]	1985 [937]	1949 [920]	1909 [901]	1879 [887]	1843 [870]	1792 [846]
					RPM	1018	1033	1070	1076	1112	1124	1147
					Watts	690	701	711	723	735	741	742

NOTE: 5 ton 1st & 2nd stage cooling speeds must be changed to low to achieve ARI performance.

[] Designates Metric Conversions



INDOOR AIRFLOW PERFORMANCE—208 VOLTS (cont.)

DOWN DISCHARGE PRESSURE DROP (ADD TO EXTERNAL STATIC PRESSURE)										
CFM [L/s]	600 [283]	800 [378]	1000 [472]	1200 [556]	1440 [661]	1600 [755]	1800 [850]	2000 [944]		
Pressure Drop—Includes W.C. [kPa]	.00	.02 [.005]	.05 [.012]	.07 [.017]	.1 [.025]	.12 [.030]	.15 [.037]	.17 [.042]		
MINIMUM RECOMMENDED FILTER SIZES										
Nominal Cooling Capacity Tons [kW]	2.0 [7.03]		2.5 [8.79]		4.0 [14.07]		5.0 [17.59]			
Minimum Filter Size—Inches [mm]	20 x 20 x 1 [508 x 508 x 25]		24 x 24 x 1 [610 x 610 x 25]		24 x 30 x 1 [610 x 762 x 1]		24 x 30 x 1 [610 x 762 x 1]			

[] Designates Metric Conversions



INDOOR AIRFLOW PERFORMANCE—230 VOLTS

Nominal Cooling Capacity Tons [kW]	Motor Speed from Factory		Blower Size/ Motor HP [W] & # of Speeds	Motor Speed	External Static Pressure—Inches W.C. [kPa] Side Discharge—Wet Coil							
	Cool	Heat			0.1 [.02]	0.2 [.05]	0.3 [.07]	0.4 [.10]	0.5 [.12]	0.6 [.15]	0.7 [.17]	
2.0 [7.03]	High	High	9 x 7 Blower 1/4 HP [186 W] 2 Speed (PSC Motor)	Low	CFM [l/s]	771 [364]	751 [354]	725 [342]	691 [326]	645 [304]	584 [276]	546 [258]
					RPM	825	870	910	950	985	1010	1030
					Watts	253	242	230	217	204	189	181
2.5 [8.79]	Low	Low	10 x 9 Blower 1/2 HP [372 W] 3 Speed (PSC Motor)	High	CFM [l/s]	946 [446]	922 [435]	882 [415]	830 [392]	769 [363]	701 [331]	630 [298]
					RPM	990	1015	1035	1055	1070	1085	1100
					Watts	315	303	288	273	257	241	226
3.0 [10.55]	Med.	Med.	10 x 9 Blower 1/2 HP [372 W] 3 Speed (PSC Motor)	Low	CFM [l/s]	1206 [569]	1182 [558]	1157 [546]	1128 [532]	1091 [515]	1044 [493]	983 [464]
					RPM	760	815	870	910	950	975	1000
					Watts	419	406	394	381	368	353	334
3.5 [12.31]	High	High	10 x 9 Blower 3/4 HP [559 W] 3 Speed (PSC Motor)	Med.	CFM [l/s]	1411 [666]	1368 [646]	1327 [626]	1285 [606]	1238 [584]	1183 [558]	1116 [527]
					RPM	865	900	935	970	1000	1020	1035
					Watts	498	481	464	447	430	411	391
4.0 [14.07]	Med.	Med.	10 x 9 Blower 3/4 HP [559 W] 3 Speed (PSC Motor)	High	CFM [l/s]	1641 [774]	1577 [744]	1515 [715]	1455 [687]	1393 [657]	1329 [627]	1262 [596]
					RPM	980	1000	1020	1035	1050	1065	1080
					Watts	589	565	543	523	503	481	456
5.0 [17.59]	High	High	12 x 9 Blower 1 HP [746 W] 4 Speed (X13 Motor)	Low	CFM [l/s]	1412 [666]	1395 [658]	1371 [647]	1339 [632]	1296 [612]	1242 [586]	1176 [555]
					RPM	859	905	951	981	1011	1034	1057
					Watts	557	530	506	483	461	437	409
5.0 [17.59]	Med.	Med.	12 x 9 Blower 1 HP [746 W] 4 Speed (X13 Motor)	Med.	CFM [l/s]	1793 [846]	1731 [817]	1665 [786]	1594 [752]	1519 [717]	1440 [660]	1356 [640]
					RPM	1053	1067	1080	1091	1101	1110	1119
					Watts	667	637	606	574	543	512	483
5.0 [17.59]	High	High	12 x 9 Blower 1 HP [746 W] 4 Speed (X13 Motor)	High	CFM [l/s]	1889 [892]	1826 [852]	1753 [827]	1672 [789]	1586 [749]	1499 [707]	1413 [667]
					RPM	1110	1117	1124	1129	1133	1139	1144
					Watts	736	715	683	646	608	574	551
5.0 [17.59]	Heat	Low (Tap 1)	12 x 9 Blower 1 HP [746 W] 4 Speed (X13 Motor)	Heat	CFM [l/s]	1319 [622]	1289 [608]	1242 [586]	1201 [567]	1148 [542]	1111 [524]	1047 [494]
					RPM	728	760	790	832	859	894	939
					Watts	222	234	241	256	263	276	287
5.0 [17.59]	Heat	High (Tap 2)	12 x 9 Blower 1 HP [746 W] 4 Speed (X13 Motor)	Heat	CFM [l/s]	1423 [672]	1390 [656]	1357 [640]	1311 [619]	1277 [603]	1233 [582]	1192 [563]
					RPM	776	796	830	861	895	927	958
					Watts	272	278	292	300	315	326	337
5.0 [17.59]	Cool	Low (Tap 3)	12 x 9 Blower 1 HP [746 W] 4 Speed (X13 Motor)	Cool	CFM [l/s]	1872 [883]	1847 [872]	1808 [853]	1772 [836]	1743 [823]	1703 [804]	1670 [788]
					RPM	956	973	1010	1023	1057	1085	1110
					Watts	562	572	584	598	613	622	636
5.0 [17.59]	Cool	High (Tap 4)	12 x 9 Blower 1 HP [746 W] 4 Speed (X13 Motor)	Cool	CFM [l/s]	2046 [966]	2010 [949]	1980 [934]	1942 [917]	1904 [899]	1867 [881]	1822 [860]
					RPM	1035	1046	1079	1086	1114	1141	1171
					Watts	721	731	743	754	770	777	770

NOTE: 5 ton 1st & 2nd stage cooling speeds must be changed to low to achieve ARI performance.

[] Designates Metric Conversions



INDOOR AIRFLOW PERFORMANCE—208 VOLTS

Nominal Cooling Capacity Tons [kW]	Motor Speed from Factory		Blower Size/ Motor HP [W] & # of Speeds	Motor Speed	External Static Pressure—Inches W.C. [kPa] Side Discharge—Wet Coil																				
	Cool	Heat			0.1 [0.02]	0.2 [0.05]	0.3 [0.07]	0.4 [1.10]	0.5 [1.12]	0.6 [1.15]	0.7 [1.17]	0.8 [1.20]													
2.0 [7.03]	High (Tap 3)	High (Tap 3)	9 x 7 Blower 1/3 HP [249 W] 3 Speed (X13 Motor)	Low (Tap 1)	CFM [l/s]	821 [387]	799 [377]	775 [366]	742 [350]	706 [333]	681 [321]	641 [303]	611 [288]	CFM [l/s]	821 [387]	799 [377]	775 [366]	742 [350]	706 [333]	681 [321]	641 [303]	611 [288]			
					RPM	878	903	953	996	1032	1075	1119	1176		RPM	878	903	953	996	1032	1075	1119	1176		
					Watts	131	134	142	145	147	154	156	161		Watts	131	134	142	145	147	154	156	161		
2.5 [8.79]	High (Tap 3)	High (Tap 3)		10 x 9 Blower 1/2 HP [373 W] 3 Speed (X13 Motor)	Med. (Tap 2)	CFM [l/s]	843 [398]	820 [387]	786 [371]	760 [359]	726 [343]	699 [330]	662 [312]	608 [287]	CFM [l/s]	843 [398]	820 [387]	786 [371]	760 [359]	726 [343]	699 [330]	662 [312]	608 [287]		
						RPM	896	924	961	1015	1045	1092	1125	1172		RPM	896	924	961	1015	1045	1092	1125	1172	
						Watts	141	144	147	155	157	163	165	164		Watts	141	144	147	155	157	163	165	164	
3.0 [10.55]	High (Tap 3)	High (Tap 3)			10 x 9 Blower 1/2 HP [373 W] 3 Speed (X13 Motor)	High (Tap 3)	CFM [l/s]	896 [423]	884 [417]	847 [400]	825 [389]	789 [372]	752 [355]	720 [340]	642 [303]	CFM [l/s]	896 [423]	884 [417]	847 [400]	825 [389]	789 [372]	752 [355]	720 [340]	642 [303]	
							RPM	935	966	1008	1047	1084	1118	1154	1176		RPM	935	966	1008	1047	1084	1118	1154	1176
							Watts	165	171	175	182	184	186	189	174		Watts	165	171	175	182	184	186	189	174
3.5 [12.31]	High (Tap 3)	High (Tap 3)	10 x 9 Blower 1/2 HP [373 W] 3 Speed (X13 Motor)			Low (Tap 1)	CFM [l/s]	1030 [486]	1010 [477]	967 [456]	922 [435]	868 [410]	825 [389]	763 [360]	709 [335]	CFM [l/s]	1030 [486]	1010 [477]	967 [456]	922 [435]	868 [410]	825 [389]	763 [360]	709 [335]	
							RPM	794	829	868	912	956	1002	1040	1093		RPM	794	829	868	912	956	1002	1040	1093
							Watts	155	164	169	178	183	192	195	203		Watts	155	164	169	178	183	192	195	203
3.5 [12.31]	High (Tap 3)	High (Tap 3)		10 x 9 Blower 1/2 HP [373 W] 3 Speed (X13 Motor)		Med. (Tap 2)	CFM [l/s]	1153 [544]	1126 [531]	1087 [513]	1042 [492]	1002 [473]	966 [456]	903 [426]	856 [404]	CFM [l/s]	1153 [544]	1126 [531]	1087 [513]	1042 [492]	1002 [473]	966 [456]	903 [426]	856 [404]	
							RPM	866	887	930	966	1010	1038	1082	1121		RPM	866	887	930	966	1010	1038	1082	1121
							Watts	207	210	220	226	234	241	246	251		Watts	207	210	220	226	234	241	246	251
3.5 [12.31]	High (Tap 3)	High (Tap 3)			10 x 9 Blower 1/2 HP [373 W] 3 Speed (X13 Motor)	High (Tap 3)	CFM [l/s]	1242 [586]	1213 [572]	1173 [554]	1132 [534]	1086 [513]	1044 [493]	1003 [473]	952 [449]	CFM [l/s]	1242 [586]	1213 [572]	1173 [554]	1132 [534]	1086 [513]	1044 [493]	1003 [473]	952 [449]	
							RPM	912	934	972	1012	1055	1081	1109	1146		RPM	912	934	972	1012	1055	1081	1109	1146
							Watts	249	252	262	271	275	282	283	288		Watts	249	252	262	271	275	282	283	288
3.5 [12.31]	High (Tap 3)	High (Tap 3)	10 x 9 Blower 1/2 HP [373 W] 3 Speed (X13 Motor)			Low (Tap 1)	CFM [l/s]	1153 [544]	1126 [531]	1087 [513]	1042 [492]	1002 [473]	966 [456]	903 [426]	856 [404]	CFM [l/s]	1153 [544]	1126 [531]	1087 [513]	1042 [492]	1002 [473]	966 [456]	903 [426]	856 [404]	
							RPM	866	887	930	966	1010	1038	1082	1121		RPM	866	887	930	966	1010	1038	1082	1121
							Watts	207	210	220	226	234	241	246	251		Watts	207	210	220	226	234	241	246	251
3.5 [12.31]	High (Tap 3)	High (Tap 3)		10 x 9 Blower 1/2 HP [373 W] 3 Speed (X13 Motor)		Med. (Tap 2)	CFM [l/s]	1242 [586]	1213 [572]	1173 [554]	1132 [534]	1086 [513]	1044 [493]	1003 [473]	952 [449]	CFM [l/s]	1242 [586]	1213 [572]	1173 [554]	1132 [534]	1086 [513]	1044 [493]	1003 [473]	952 [449]	
							RPM	912	934	972	1012	1055	1081	1109	1146		RPM	912	934	972	1012	1055	1081	1109	1146
							Watts	249	252	262	271	275	282	283	288		Watts	249	252	262	271	275	282	283	288
3.5 [12.31]	High (Tap 3)	High (Tap 3)			10 x 9 Blower 1/2 HP [373 W] 3 Speed (X13 Motor)	High (Tap 3)	CFM [l/s]	1338 [631]	1309 [618]	1278 [603]	1234 [582]	1182 [558]	1135 [536]	1087 [513]	1007 [475]	CFM [l/s]	1338 [631]	1309 [618]	1278 [603]	1234 [582]	1182 [558]	1135 [536]	1087 [513]	1007 [475]	
							RPM	963	983	1016	1049	1096	1121	1142	1159		RPM	963	983	1016	1049	1096	1121	1142	1159
							Watts	304	307	316	321	328	332	330	315		Watts	304	307	316	321	328	332	330	315
3.5 [12.31]	High (Tap 3)	High (Tap 3)	10 x 9 Blower 1/2 HP [373 W] 3 Speed (X13 Motor)			Low (Tap 1)	CFM [l/s]	1228 [580]	1187 [560]	1140 [538]	1105 [522]	1062 [501]	1008 [476]	959 [453]	911 [430]	CFM [l/s]	1228 [580]	1187 [560]	1140 [538]	1105 [522]	1062 [501]	1008 [476]	959 [453]	911 [430]	
							RPM	761	808	841	884	920	960	999	1038		RPM	761	808	841	884	920	960	999	1038
							Watts	150	170	180	183	185	190	195	215		Watts	150	170	180	183	185	190	195	215
3.5 [12.31]	High (Tap 3)	High (Tap 3)		10 x 9 Blower 1/2 HP [373 W] 3 Speed (X13 Motor)		Med. (Tap 2)	CFM [l/s]	1454 [686]	1433 [676]	1392 [657]	1354 [639]	1322 [624]	1283 [606]	1238 [584]	1192 [563]	CFM [l/s]	1454 [686]	1433 [676]	1392 [657]	1354 [639]	1322 [624]	1283 [606]	1238 [584]	1192 [563]	
							RPM	923	946	976	1015	1044	1085	1126	1146		RPM	923	946	976	1015	1044	1085	1126	1146
							Watts	301	309	316	327	337	348	356	363		Watts	301	309	316	327	337	348	356	363
3.5 [12.31]	High (Tap 3)	High (Tap 3)			10 x 9 Blower 1/2 HP [373 W] 3 Speed (X13 Motor)	High (Tap 3)	CFM [l/s]	1544 [729]	1531 [723]	1473 [695]	1440 [680]	1398 [660]	1361 [642]	1317 [622]	1263 [596]	CFM [l/s]	1544 [729]	1531 [723]	1473 [695]	1440 [680]	1398 [660]	1361 [642]	1317 [622]	1263 [596]	
							RPM	958	973	1025	1046	1078	1109	1147	1163		RPM	958	973	1025	1046	1078	1109	1147	1163
							Watts	343	350	364	371	382	391	401	396		Watts	343	350	364	371	382	391	401	396

NOTES: (1) Do not operate 2 ton models below 700 CFM. (2) Do not operate 2 1/2 or 3 ton models below 875 CFM. (3) Cooling speed must be adjusted as follows to achieve ARI performance: medium speed for 2, 3, 3 1/2 and 4 ton models; low speed for 2 1/2 and 1st & 2nd stage 5 ton.

[] Designates Metric Conversions



INDOOR AIRFLOW PERFORMANCE—208 VOLTS (continued)

Nominal Cooling Capacity Tons [kW]	Motor Speed from Factory		Blower Size/ Motor HP [W] & # of Speeds	Motor Speed	CFM [L/s] Air Delivery/RPM/Watts—208 Volts Side Discharge—Wet Coil									
	Cool	Heat			External Static Pressure—Inches W.C. [kPa]									
					0.1 [1.02]	0.2 [1.05]	0.3 [1.07]	0.4 [1.10]	0.5 [1.12]	0.6 [1.15]	0.7 [1.17]	0.8 [1.20]		
4.0 [14.07]	High (Tap 3)	High (Tap 3)	10 x 9 Blower 3/4 HP [559 W] 3 Speed (X13 Motor)	Low (Tap 1)	CFM [L/s]	1454 [686]	1433 [676]	1392 [657]	1354 [639]	1322 [624]	1283 [606]	1238 [584]	1192 [563]	
					RPM	923	946	976	1015	1044	1085	1126	1146	
					Watts	301	309	316	327	337	348	356	363	
	High (Tap 3)	High (Tap 3)		Med. (Tap 2)	CFM [L/s]	1642 [775]	1621 [765]	1584 [748]	1542 [728]	1496 [706]	1451 [685]	1396 [659]	1299 [613]	
					RPM	1006	1022	1064	1090	1114	1151	1160	1172	
					Watts	405	412	422	435	442	449	440	414	
5.0 [17.59]	1st Stage High (Tap 2)	High (Tap 2)	12 x 9 Blower 1 HP [746 W] 4 Speed (X13 Motor)	High (Tap 3)	CFM [L/s]	1896 [895]	1863 [879]	1776 [838]	1694 [799]	1603 [757]	1528 [721]	1424 [672]	1316 [621]	
					RPM	1146	1147	1159	1171	1173	1180	1188	1195	
					Watts	624	614	583	554	522	497	467	432	
	2nd Stage High (Tap 4)	High (Tap 2)		High (Tap 2)	CFM [L/s]	1310 [618]	1288 [608]	1238 [584]	1204 [568]	1149 [542]	1104 [521]	1035 [488]	971 [458]	
					RPM	731	757	789	826	857	894	937	993	
					Watts	218	229	237	250	258	270	280	294	
2nd Stage High (Tap 4)	High (Tap 2)	High (Tap 2)	CFM [L/s]	1418 [669]	1386 [654]	1352 [638]	1307 [617]	1270 [599]	1221 [576]	1180 [557]	1117 [527]			
			RPM	774	794	829	860	892	922	955	1015			
			Watts	267	273	287	295	308	316	328	343			
2nd Stage High (Tap 4)	High (Tap 2)	High (Tap 2)	CFM [L/s]	1858 [877]	1821 [859]	1782 [841]	1752 [827]	1714 [809]	1678 [792]	1640 [774]	1607 [758]			
			RPM	944	968	994	1019	1041	1072	1089	1111			
			Watts	541	555	564	578	586	598	611	617			
2nd Stage High (Tap 4)	High (Tap 2)	High (Tap 2)	CFM [L/s]	2017 [952]	1985 [937]	1949 [920]	1909 [901]	1879 [887]	1843 [870]	1792 [846]	1737 [820]			
			RPM	1018	1033	1070	1076	1112	1124	1147	1152			
			Watts	690	701	711	723	735	741	742	728			

NOTES: (1) Do not operate 2 ton models below 700 CFM. (2) Do not operate 2 1/2 or 3 ton models below 875 CFM. (3) Cooling speed must be adjusted as follows to achieve ARI performance: medium speed for 2, 3, 3 1/2 and 4 ton models; low speed for 2 1/2 and 1st & 2nd stage 5 ton.

[] Designates Metric Conversions

DOWN DISCHARGE PRESSURE DROP (ADD TO EXTERNAL STATIC PRESSURE)								
CFM [L/s]	600 [283]	800 [378]	1000 [472]	1200 [566]	1400 [661]	1600 [755]	1800 [849]	2000 [944]
Pressure Drop—Includes W.C. [kPa]	0	.02 [1.005]	.05 [1.012]	.07 [1.017]	.1 [1.025]	.12 [1.030]	.15 [1.037]	.17 [1.042]



INDOOR AIRFLOW PERFORMANCE—230 VOLTS

Nominal Cooling Capacity Tons [kW]	Motor Speed from Factory		Blower Size/ Motor HP [W] & # of Speeds	Motor Speed	CFM [L/s] Air Delivery/RPM/Watts—230 Volts Side Discharge—Wet Coil										
	Cool	Heat			External Static Pressure—Inches W.C. [kPa]										
					0.1 [1.02]	0.2 [1.05]	0.3 [1.07]	0.4 [1.10]	0.5 [1.12]	0.6 [1.15]	0.7 [1.17]	0.8 [1.20]			
2.0 [14.07]	High (Tap 3)	High (Tap 3)	9 x 7 Blower 1/3 HP [249 W] 3 Speed (X13 Motor)	Low (Tap 1)	CFM [L/s]	829 [391]	808 [381]	789 [372]	756 [357]	737 [348]	697 [329]	668 [315]	615 [290]		
					RPM	890	915	961	1000	1046	1089	1121	1173		
					Watts	137	139	148	151	160	166	167			
	High (Tap 3)	Med. (Tap 2)		CFM [L/s]	853 [403]	832 [393]	804 [379]	779 [368]	745 [352]	724 [342]	688 [325]	630 [297]			
				RPM	901	928	984	1013	1054	1099	1137	1185			
				Watts	146	149	159	161	165	173	176	173			
		High (Tap 3)		CFM [L/s]	912 [430]	896 [423]	863 [407]	839 [396]	815 [385]	787 [371]	736 [347]	656 [310]			
				RPM	940	977	1017	1062	1088	1139	1165	1181			
				Watts	171	179	183	192	194	203	199	182			
2.5 [18.79]	High (Tap 3)	High (Tap 3)	10 x 9 Blower 1/2 HP [373 W] 3 Speed (X13 Motor)	Low (Tap 1)	CFM [L/s]	1039 [490]	1021 [482]	971 [458]	932 [440]	887 [419]	839 [396]	797 [376]	735 [347]		
					RPM	798	833	878	922	955	1011	1061	1093		
					Watts	159	168	175	185	189	200	210	213		
					High (Tap 3)	Med. (Tap 2)	CFM [L/s]	1169 [552]	1140 [538]	1111 [524]	1068 [504]	1030 [486]	995 [470]	949 [448]	895 [422]
							RPM	868	893	932	978	1010	1048	1086	1129
							Watts	213	217	228	239	244	254	258	268
						High (Tap 3)	CFM [L/s]	1256 [593]	1231 [581]	1201 [567]	1161 [548]	1115 [526]	1076 [508]	1043 [492]	999 [471]
							RPM	921	942	976	1018	1053	1093	1131	1149
							Watts	259	263	272	284	290	299	309	307
3.0 [10.55]	High (Tap 3)	High (Tap 3)	10 x 9 Blower 1/2 HP [373 W] 3 Speed (X13 Motor)	Low (Tap 1)	CFM [L/s]	1169 [552]	1140 [538]	1111 [524]	1068 [504]	1030 [486]	995 [470]	949 [448]	895 [422]		
					RPM	868	893	932	978	1010	1048	1086	1129		
					Watts	213	217	228	239	244	254	258	268		
					High (Tap 3)	Med. (Tap 2)	CFM [L/s]	1256 [593]	1231 [581]	1201 [567]	1161 [548]	1115 [526]	1076 [508]	1043 [492]	999 [471]
							RPM	921	942	976	1018	1053	1093	1131	1149
							Watts	259	263	272	284	290	299	309	307
						High (Tap 3)	CFM [L/s]	1357 [640]	1330 [628]	1292 [610]	1262 [596]	1225 [578]	1178 [556]	1110 [524]	1033 [488]
							RPM	974	1003	1036	1071	1103	1134	1153	1169
							Watts	318	323	333	343	347	356	345	328
3.5 [12.31]	High (Tap 3)	High (Tap 3)	10 x 9 Blower 1/2 HP [373 W] 3 Speed (X13 Motor)	Low (Tap 1)	CFM [L/s]	1241 [586]	1203 [568]	1155 [545]	1119 [528]	1082 [511]	1032 [487]	994 [469]	950 [448]		
					RPM	771	815	848	886	932	965	1004	1044		
					Watts	155	162	170	182	193	200	210	220		
					High (Tap 3)	Med. (Tap 2)	CFM [L/s]	1459 [689]	1438 [679]	1409 [665]	1371 [647]	1337 [631]	1296 [612]	1258 [594]	1223 [577]
							RPM	931	958	993	1031	1058	1097	1133	1158
							Watts	308	319	331	339	349	362	373	381
						High (Tap 3)	CFM [L/s]	1562 [737]	1538 [726]	1500 [708]	1456 [687]	1434 [677]	1383 [653]	1339 [632]	1270 [599]
							RPM	960	991	1017	1055	1089	1121	1154	1169
							Watts	353	364	375	388	398	408	418	405

NOTES: (1) Do not operate 2 ton models below 700 CFM. (2) Do not operate 2 1/2 or 3 ton models below 875 CFM. (3) Cooling speed must be adjusted as follows to achieve ARI performance: medium speed for 2, 3, 3 1/2 and 4 ton models; low speed for 2 1/2 and 1st & 2nd stage 5 ton.

[] Designates Metric Conversions



INDOOR AIRFLOW PERFORMANCE—230 VOLTS (continued)

Nominal Cooling Capacity Tons [kW]	Motor Speed from Factory		Blower Size/ Motor HP [W] & # of Speeds	Motor Speed	CFM [L/s] Air Delivery/RPM/Watts—230 Volts Side Discharge—Wet Coil									
	Cool	Heat			External Static Pressure—Inches W.C. [kPa]									
					0.1 [0.02]	0.2 [0.05]	0.3 [0.07]	0.4 [1.10]	0.5 [1.12]	0.6 [1.15]	0.7 [1.17]	0.8 [2.0]		
4.0 [14.07]	High (Tap 3)	High (Tap 3)	10 x 9 3/4 HP [559 W] 3 Speed (X13 Motor)	Low (Tap 1)	CFM [L/s]	1459 [689]	1438 [679]	1409 [665]	1371 [647]	1337 [631]	1296 [612]	1258 [594]	1223 [577]	
					RPM	931	958	993	1031	1058	1097	1133	1158	
					Watts	308	319	331	339	349	362	373	381	
	Med. (Tap 2)	High (Tap 3)		CFM [L/s]	1662 [784]	1648 [778]	1607 [758]	1579 [745]	1538 [726]	1477 [697]	1392 [657]	1305 [616]		
				RPM	1016	1037	1072	1098	1129	1156	1169	1179		
				Watts	421	429	443	453	465	465	446	420		
5.0 [17.59]	1st Stage High (Tap 2)	High (Tap 2)	12 x 9 1 HP [746 W] 4 Speed (X13 Motor)	High (Tap 3)	CFM [L/s]	1910 [901]	1873 [884]	1798 [849]	1715 [809]	1621 [765]	1536 [725]	1422 [671]	1323 [624]	
					RPM	1149	1160	1163	1169	1175	1187	1184	1205	
					Watts	638	625	601	571	536	506	469	440	
	2nd Stage High (Tap 4)	High (Tap 2)		Heat / 1st Stage Cool	CFM [L/s]	1319 [622]	1289 [608]	1242 [586]	1201 [567]	1148 [542]	1111 [524]	1047 [494]	985 [465]	
				Low (Tap 1)	RPM	728	760	790	832	859	894	939	992	
				High (Tap 2)	Watts	222	234	241	256	263	276	287	304	
5.0 [17.59]	2nd Stage High (Tap 4)	High (Tap 2)	12 x 9 1 HP [746 W] 4 Speed (X13 Motor)	High (Tap 3)	Heat / 1st Stage Cool	CFM [L/s]	1423 [672]	1390 [656]	1357 [640]	1277 [603]	1233 [582]	1192 [563]	1137 [537]	
					High (Tap 2)	RPM	776	796	830	861	895	927	958	999
					Low (Tap 3)	Watts	272	278	292	300	315	326	337	352
	2nd Stage High (Tap 4)	High (Tap 2)		Stage Cool	CFM [L/s]	1872 [883]	1847 [872]	1808 [853]	1772 [836]	1743 [823]	1703 [804]	1670 [788]	1639 [774]	
				Low (Tap 3)	RPM	956	973	1010	1023	1057	1085	1110	1146	
				High (Tap 4)	Watts	562	572	584	598	613	622	636	646	
2nd Stage High (Tap 4)	High (Tap 2)	Stage Cool	CFM [L/s]	2046 [966]	2010 [949]	1980 [934]	1942 [917]	1904 [899]	1867 [881]	1822 [860]	1758 [830]			
		High (Tap 4)	RPM	1035	1046	1079	1086	1114	1141	1171	1163			
		Low (Tap 4)	Watts	721	731	743	754	770	777	770	751			

NOTES: (1) Do not operate 2 ton models below 700 CFM. (2) Do not operate 2 1/2 or 3 ton models below 875 CFM. (3) Cooling speed must be adjusted as follows to achieve ARI performance: medium speed for 2, 3, 3 1/2 and 4 ton models; low speed for 2 1/2 and 1st & 2nd stage 5 ton.

[] Designates Metric Conversions

DOWN DISCHARGE PRESSURE DROP (ADD TO EXTERNAL STATIC PRESSURE)								
CFM [L/s]	600 [283]	800 [378]	1000 [472]	1200 [566]	1400 [661]	1600 [755]	1800 [849]	2000 [944]
Pressure Drop—Includes W.C. [kPa]	0	.02 [.005]	.05 [.012]	.07 [.017]	.1 [.025]	.12 [.030]	.15 [.037]	.17 [.042]



ELECTRICAL DATA – RSNL- SERIES											
		-B024JK	-B030JK	-B036CK	-B036JK	-B042CK	-B042JK	-B048CK	-B048JK	-C060CK	-C060JK
Unit Information	Unit Operating Voltage Range	187-253	187-253	187-253	187-253	187-253	187-253	187-253	187-253	197-253	197-253
	Minimum Circuit Ampacity	19/19	22/22	17/17	25/25	22/22	27/27	24/24	34/34	32/32	42/42
	Minimum Overcurrent Protection Device Size	20/20	25/25	20/20	25/25	25/25	30/30	25/25	35/35	35/35	45/45
	Maximum Overcurrent Protection Device Size	30/30	35/35	25/25	40/40	30/30	40/40	35/35	50/50	45/45	60/60
Compressor Motor	No.	1	1	1	1	1	1	1	1	1	1
	Volts	208/230	208/230	208/230	208/230	208/230	208/230	208/230	208/230	208/230	208/230
	Phase	1	1	3	1	3	1	3	1	3	1
	HP	2 1/6	2 2/3	3 1/3	3 1/3	3 1/2	3 1/2	4	4	5	5
	RPM	3450	3450	3450	3450	3450	3450	3450	3450	3450	3450
	Amps (RLA)	12.8/12.8	14.1/14.1	10.4/10.4	16.7/16.7	13.5/13.5	17.9/17.9	13.7/13.7	21.8/21.8	17.6/17.6	25.6/25.6
	Amps (LRA)	58.3/58.3	73/73	88/88	79/79	88/88	112/112	83.1/83.1	117/117	135/135	118/118
Condenser Motor	No.	1	1	1	1	1	1	1	1	1	1
	Volts	208/230	208/230	208/230	208/230	208/230	208/230	208/230	208/230	208/230	208/230
	Phase	1	1	1	1	1	1	1	1	1	1
	HP	1/5	1/5	1/5	1/5	1/3	1/3	1/3	1/3	1/3	1/3
	Amps (FLA)	1.3	1.3	1.3	1.3	2	2	2	2	2	2
	Amps (LRA)	2.3	2.3	2.3	2.3	3.9	3.9	3.9	3.9	3.9	3.9
Evaporator Fan	No.	1	1	1	1	1	1	1	1	1	1
	Volts	208/230	208/230	208/230	208/230	208/230	208/230	208/230	208/230	208/230	208/230
	Phase	1	1	1	1	1	1	1	1	1	1
	HP	1/4	1/2	1/2	1/2	1/2	1/2	3/4	3/4	1	1
	Amps (FLA)	1.3	2.4	2.4	2.4	2.4	2.4	4.4	4.4	7.6	7.6
	Amps (LRA)	2.3	5.1	5.1	5.1	5.1	5.1	9.5	9.5	0	0

1. Horsepower Per Compressor.

2. Amp Draw Per Motor. Multiply Value By Number of Motors to Determine Total Amps.



ELECTRICAL DATA – RSPL SERIES

		-B024JK	-B030JK	-B036CK	-B036JK	-B042CK	-B042JK	-B048CK	-B048JK	-B060CK	-B060JK
Unit Information	Unit Operating Voltage Range	187-253	187-253	187-253	187-253	187-253	187-253	187-253	187-253	197-253	197-253
	Minimum Circuit Ampacity	21/21	24/24	19/19	27/27	24/24	29/29	26/26	36/36	32/32	42/42
	Minimum Overcurrent Protection Device Size	25/25	25/25	20/20	30/30	25/25	30/30	30/30	40/40	35/35	45/45
	Maximum Overcurrent Protection Device Size	30/30	35/35	25/25	40/40	35/35	45/45	35/35	50/50	45/45	60/60
Compressor Motor	No.	1	1	1	1	1	1	1	1	1	1
	Volts	208/230	208/230	208/230	208/230	208/230	208/230	208/230	208/230	208/230	208/230
	Phase	1	1	3	1	3	1	3	1	3	1
	HP	2 1/6	2 2/3	3 1/3	3 1/3	3 1/2	3 1/2	4	4	5	5
	RPM	3450	3450	3450	3450	3450	3450	3450	3450	3450	3450
	Amps (RLA)	12.8/12.8	14.1/14.1	10.4/10.4	16.7/16.7	13.5/13.5	17.9/17.9	13.7/13.7	21.8/21.8	17.6/17.6	25.6/25.6
	Amps (LRA)	58.3/58.3	73/73	88/88	79/79	88/88	112/112	83.1/83.1	117/117	135/135	118/118
Condenser Motor	No.	1	1	1	1	1	1	1	1	1	1
	Volts	208/230	208/230	208/230	208/230	208/230	208/230	208/230	208/230	208/230	208/230
	Phase	1	1	1	1	1	1	1	1	1	1
	HP	1/5	1/5	1/5	1/5	1/3	1/3	1/3	1/3	1/3	1/3
	Amps (FLA)	1.3	1.3	1.3	1.3	2	2	2	2	2	2
	Amps (LRA)	2.3	2.3	2.3	2.3	3.9	3.9	3.9	3.9	3.9	3.9
Evaporator Fan	No.	1	1	1	1	1	1	1	1	1	1
	Volts	208/230	208/230	208/230	208/230	208/230	208/230	208/230	208/230	208/230	208/230
	Phase	1	1	1	1	1	1	1	1	1	1
	HP	1/3	1/2	1/2	1/2	1/2	1/2	3/4	3/4	1	1
	Amps (FLA)	2.8	4.1	4.1	4.1	4.1	4.1	6	6	7.6	7.6
	Amps (LRA)	0	0	0	0	0	0	0	0	0	0

1. Horsepower Per Compressor.
2. Amp Draw Per Motor. Multiply Value By Number of Motors to Determine Total Amps.

Copper Wire Size—AWG (1% Voltage Drop)

SUPPLY WIRE LENGTH- FEET	CIRCUIT AMPACITY																						
	15	20	25	30	35	40	45	50	55	60	65	70	75	80	85	90	95	100	105	110	115	120	125
300	4	3	2	2	1	1/0	1/0	2/0	2/0	3/0	3/0	3/0	4/0	4/0	4/0	4/0	250	250	250	250	300	300	300
250	4	4	3	3	2	1	1	1/0	1/0	2/0	2/0	2/0	3/0	3/0	3/0	4/0	4/0	4/0	4/0	4/0	250	250	250
200	6	4	4	4	3	2	2	1	1	1/0	1/0	1/0	2/0	2/0	2/0	3/0	3/0	3/0	3/0	3/0	4/0	4/0	4/0
150	8	6	6	4	4	4	3	3	2	2	1	1	1/0	1/0	1/0	1/0	2/0	2/0	2/0	2/0	2/0	3/0	3/0
100	10	8	8	6	6	6	4	4	4	3	3	2	2	2	1	1	1	1	1	1/0	1/0	1/0	1/0
50	14	12	10	10	8	8	6	6	6	4	4	4	3	3	3	2	2	2	2	2	1	1	1

Notes: 1. Wire size based on 60°C. type copper conductors below 100 ampacity.

2. Wire size based on 75°C. type copper conductors for 100 ampacity and above.



208-240 VOLT, SINGLE PHASE, 60 HZ, AUXILIARY ELECTRIC HEATER KITS CHARACTERISTICS AND APPLICATION

Single Power Supply For Both Unit and Heater Kit

Unit Model No. RSNL-	Heater Kit					Unit			Heater Kit			Air Conditioner		
	RXQJ- Heater Kit Nominal kW	No. of Elements	No. of Sequence Steps	Rated Heater kW @ 208/240 V	Heater KBTU/Hr @ 208/240 V	Heater Amp. @ 208/240 V	Unit Min. Ckt. Ampacity @ 208/240 V	Over Current Protective Device Size		Min. Ckt. Ampacity 208/240V	Max. Fuse Size 208/240V	Min. Circuit Ampacity 208/240 V	Over Current Protective Device Size	
								Min./Max. @ 208 V	Min./Max. @ 240 V				Min./Max. @ 208 V	Min./Max. @ 240 V
B024JK	No Heat A05J A10J	1 2	1 1	3.6/4.8 7.2/9.6	12.28/16.38 24.57/32.76	17.3/20.0 34.6/40.0	19/19 24/27 46/52	20/30 25/30 50/50	20/30 30/30 60/60	— 22/25 44/50	25/25 45/50	19/19	20/30	20/30
B030JK	No Heat A05J A10J	1 2	1 1	3.6/4.8 7.2/9.6	12.28/16.38 24.57/32.76	17.3/20.0 34.6/40.0	22/22 25/28 47/53	25/35 30/35 60/60	25/35 30/35 60/60	22/25 44/50	25/25 45/50	22/22	25/35	25/35
B036JK	No Heat A10J A15J	2 3	1 1	7.2/9.6 10.8/14.4	24.57/32.76 36.85/49.13	34.6/40.0 51.9/60.0	25/25 47/53 68/78	25/40 50/50 70/70	25/40 60/60 80/80	— 44/50 65/75	45/50 70/80	25/25	25/40	25/40
B042JK	No Heat A10J A15J	2 3	1 1	7.2/9.6 10.8/14.4	24.57/32.76 36.85/49.13	34.6/40.0 51.9/60.0	27/27 47/53 68/79	30/40 50/50 70/70	30/40 60/60 80/80	— 44/50 65/75	45/50 70/80	27/27	30/40	30/40
B048JK	No Heat B10J B15J	2 3	1 1	7.2/9.6 10.8/14.4	24.57/32.76 36.85/49.13	34.6/40.0 51.9/60.0	34/34 49/56 71/81	35/50 50/50 80/80	35/50 60/60 90/90	— 44/50 65/75	45/50 70/80	34/34	35/50	35/50
C060JK	No Heat B10J B15J	2 3	1 1	7.2/9.6 10.8/14.4	24.57/32.76 36.85/49.13	34.6/40.0 51.9/60.0	42/42 53/60 75/85	45/60 60/60 80/80	45/60 60/60 90/90	— 44/50 65/75	45/50 70/80	42/42	45/60	45/60

208-240 VOLT, THREE PHASE, 60 HZ, AUXILIARY ELECTRIC HEATER KITS CHARACTERISTICS AND APPLICATION

Single Power Supply For Both Unit and Heater Kit

Unit Model No. RSNL-	Heater Kit					Unit			Heater Kit			Air Conditioner		
	RXQJ- Heater Kit Nominal kW	No. of Elements	No. of Sequence Steps	Rated Heater kW @ 208/240 V	Heater KBTU/Hr @ 208/240 V	Heater Amp. @ 208/240 V	Unit Min. Ckt. Ampacity @ 208/240 V	Over Current Protective Device Size		Min. Ckt. Ampacity 208/240V	Max. Fuse Size 208/240V	Min. Circuit Ampacity 208/240 V	Over Current Protective Device Size	
								Min./Max. @ 208 V	Min./Max. @ 240 V				Min./Max. @ 208 V	Min./Max. @ 240 V
B036CK	No Heat A10C A15C	—	—	7.2/9.6 10.8/14.4	24.57/32.76 36.85/49.13	20.0/23.1 30.1/34.7	17/17 28/32 41/47	20/25 30/30 45/45	20/25 35/35 50/50	— 25/29 38/44	25/30 40/45	19/19	20/25	20/25
B042CK	No Heat A10C A15C	—	—	7.2/9.6 10.8/14.4	24.57/32.76 36.85/49.13	20.0/23.1 30.1/34.7	22/22 28/32 41/47	25/30 30/30 45/45	25/30 35/35 50/50	— 25/29 38/44	25/30 40/45	24/24	25/35	25/35
B048CK	No Heat A10C A15C	—	—	7.2/9.6 10.8/14.4	24.57/32.76 36.85/49.13	20.0/23.1 30.1/34.7	24/24 31/35 44/49	25/35 35/35 45/45	25/35 35/35 50/50	— 25/29 38/44	25/30 40/45	26/26	30/35	30/35
C060CK	No Heat A10C A15C	—	—	7.2/9.6 10.8/14.4	24.57/32.76 36.85/49.13	20.0/23.1 30.1/34.7	32/32 35/39 48/53	35/45 35/45 50/50	35/45 40/45 60/60	— 25/29 38/44	25/30 40/45	32/32	35/45	35/45



208-240 VOLT, SINGLE PHASE, 60 HZ, AUXILIARY ELECTRIC HEATER KITS CHARACTERISTICS AND APPLICATION															
Separate Power Supply For Both Unit and Heater Kit															
Unit Model No. RSPL-	Heater Kit						Unit				Heater Kit			Air Conditioner	
	RXQJ- Heater Kit Nominal kW	No. of Elements	No. of Sequence Steps	Rated Heater kW @ 208/240 V	Heater KBTU/Hr @ 208/240 V	Heater Amp. @ 208/240 V	Unit Min. Ckt. Ampacity @ 208/240 V	Over Current Protective Device Size		Min. Circuit Ampacity 208/240V	Max. Fuse Size 208/240V	Min. Ckt. Ampacity 208/240V	Over Current Protective Device Size		
								Min./Max. @ 208 V	Min./Max. @ 240 V				Min./Max. @ 208 V	Min./Max. @ 240 V	
B024JK	No Heat A05J A10J	1 2	1 1	3.6/4.8 7.2/9.6	12.28/16.38 24.57/32.76	17.3/20.0 34.6/40.0	21/21 26/29 47/54	25/30 30/30 50/50	25/30 30/30 60/60	21/21	25/25 45/50	22/25 44/50	25/30	25/30	
B030JK	No Heat A05J A10J	1 2	1 1	3.6/4.8 7.2/9.6	12.28/16.38 24.57/32.76	17.3/20.0 34.6/40.0	24/24 27/31 49/56	25/35 30/35 50/50	25/35 35/35 60/60	24/24	25/25 45/50	22/25 44/50	25/35	25/35	
B036JK	No Heat A10J A15J	2 3	1 1	7.2/9.6 10.8/14.4	24.57/32.76 36.85/49.13	34.6/40.0 51.9/60.0	27/27 49/56 70/81	30/40 50/50 70/70	30/40 60/60 90/90	27/27	45/50 70/80	44/50 65/75	30/40	30/40	
B042JK	No Heat A10J A15J	2 3	1 1	7.2/9.6 10.8/14.4	24.57/32.76 36.85/49.13	34.6/40.0 51.9/60.0	29/29 49/56 70/81	30/45 50/50 70/70	30/45 60/60 90/90	29/29	45/50 70/80	44/50 65/75	30/45	30/45	
B048JK	No Heat B10J B15J	2 3	1 1	7.2/9.6 10.8/14.4	24.57/32.76 36.85/49.13	34.6/40.0 51.9/60.0	36/36 51/58 73/83	40/50 60/60 80/80	40/50 60/60 90/90	36/36	45/50 70/80	44/50 65/75	40/50	40/50	
B060JK	No Heat B10J B15J	2 3	1 1	7.2/9.6 10.8/14.4	24.57/32.76 36.85/49.13	34.6/40.0 51.9/60.0	42/42 53/60 75/85	45/60 60/60 80/80	45/60 60/60 90/90	42/42	45/50 70/80	44/50 65/75	45/60	45/60	

208-240 VOLT, THREE PHASE, 60 HZ, AUXILIARY ELECTRIC HEATER KITS CHARACTERISTICS AND APPLICATION															
Separate Power Supply For Both Unit and Heater Kit															
Unit Model No. RSPL-	Heater Kit						Unit				Heater Kit			Air Conditioner	
	RXQJ- Heater Kit Nominal kW	No. of Elements	No. of Sequence Steps	Rated Heater kW @ 208/240 V	Heater KBTU/Hr @ 208/240 V	Heater Amp. @ 208/240 V	Unit Min. Ckt. Ampacity @ 208/240 V	Over Current Protective Device Size		Min. Circuit Ampacity 208/240V	Max. Fuse Size 208/240V	Min. Ckt. Ampacity 208/240V	Over Current Protective Device Size		
								Min./Max. @ 208 V	Min./Max. @ 240 V				Min./Max. @ 208 V	Min./Max. @ 240 V	
B036CK	No Heat A10C A15C	—	—	7.2/9.6 10.8/14.4	24.57/32.76 36.85/49.13	20.0/23.1 30.1/34.7	19/19 31/34 43/49	20/25 35/35 45/45	20/25 35/35 50/50	19/19	25/30 40/45	25/29 38/44	20/25	20/25	
B042CK	No Heat A10C A15C	—	—	7.2/9.6 10.8/14.4	24.57/32.76 36.85/49.13	20.0/23.1 30.1/34.7	24/24 31/34 43/49	25/35 35/35 45/45	25/35 35/35 50/50	24/24	25/30 40/45	25/29 38/44	25/35	25/35	
B048CK	No Heat A10C A15C	—	—	7.2/9.6 10.8/14.4	24.57/32.76 36.85/49.13	20.0/23.1 30.1/34.7	26/26 33/37 46/51	30/35 35/35 50/50	30/35 40/40 60/60	26/26	25/30 40/45	25/29 38/44	30/35	30/35	
B060CK	No Heat A10C A15C	—	—	7.2/9.6 10.8/14.4	24.57/32.76 36.85/49.13	20.0/23.1 30.1/34.7	32/32 35/39 48/53	35/45 35/45 50/50	35/45 40/45 60/60	32/32	25/30 40/45	25/29 38/44	35/45	35/45	



UNIT DIMENSIONS PACKAGE AIR CONDITIONERS

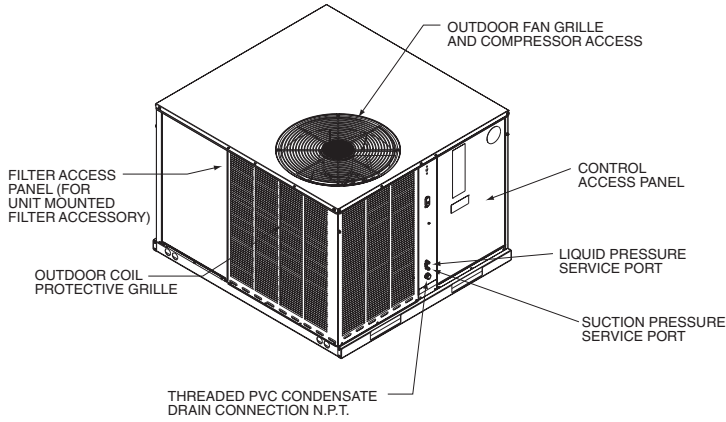

IMPORTANT: UNIT MUST BE LEVEL TO PREVENT WATER MIGRATION

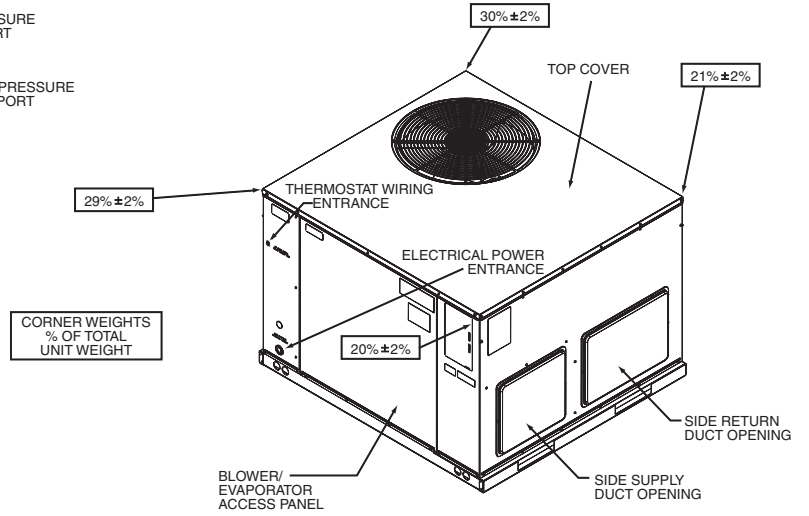

TOP VIEW

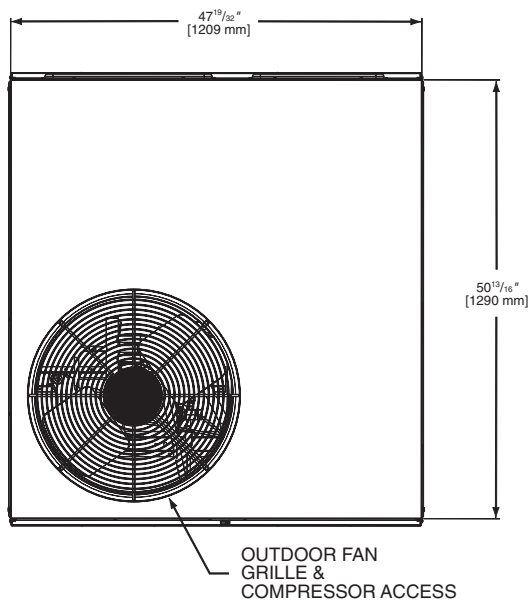

BOTTOM VIEW

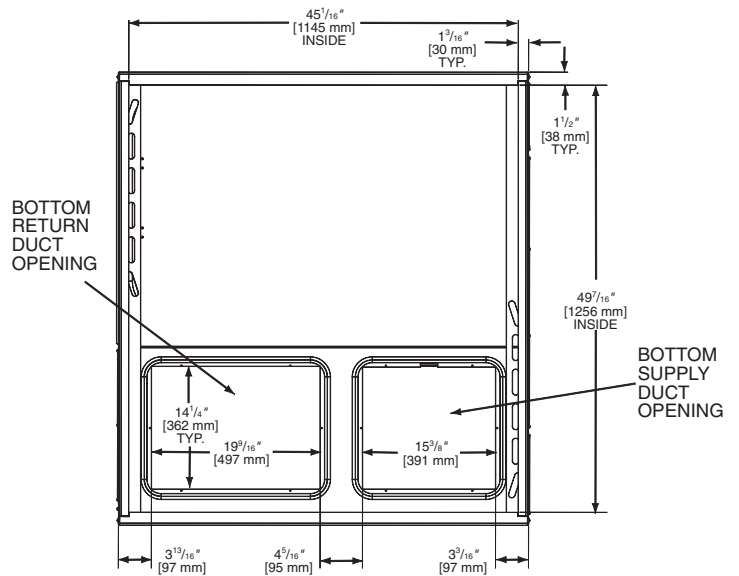

[] Designates Metric Conversions



SIDE VIEW

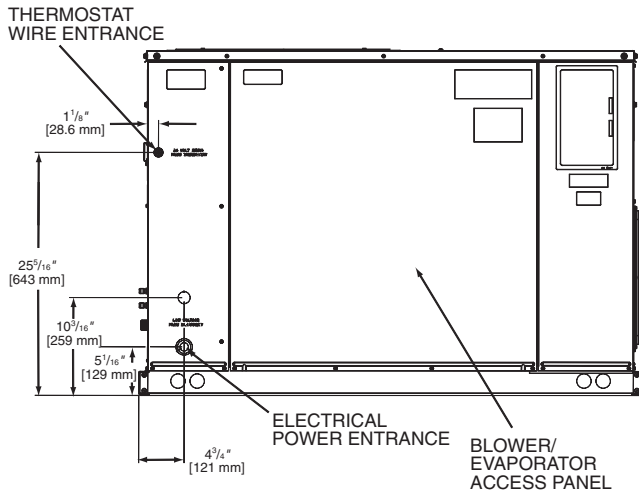

SIDE VIEW

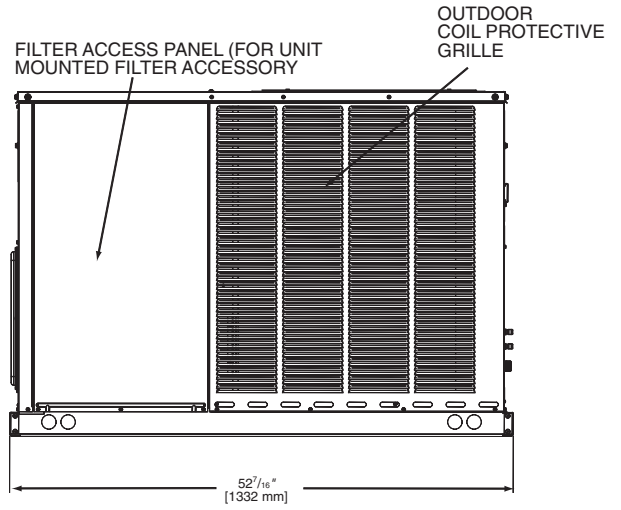

FRONT VIEW

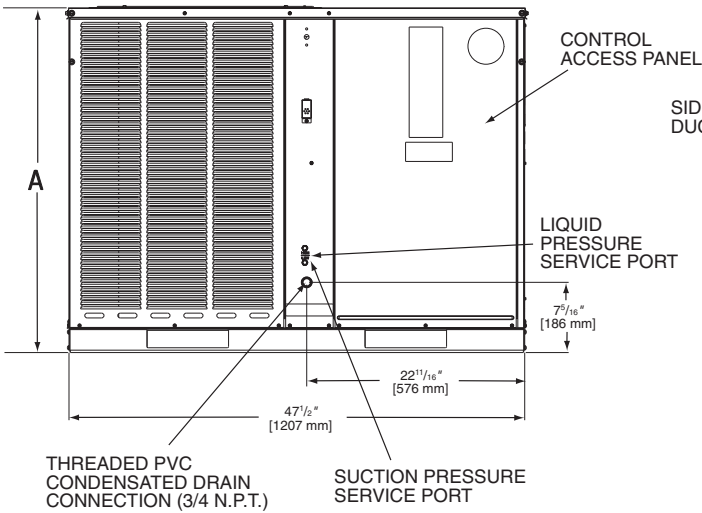

REAR VIEW

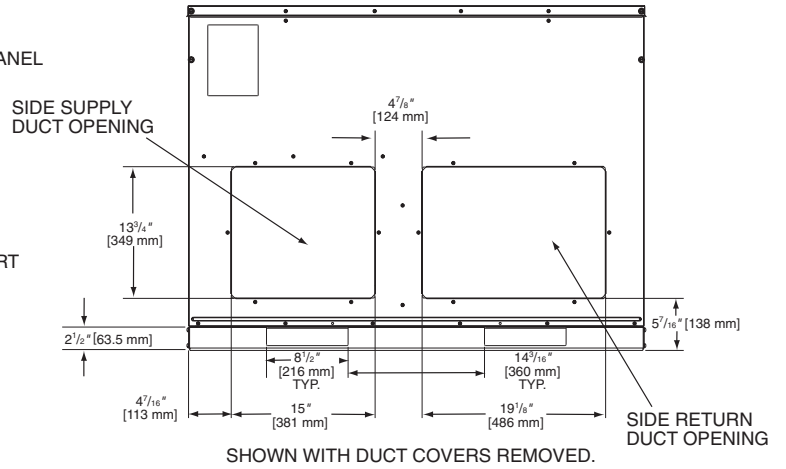

Model #	Height "A"
B024, B030, B036	35 ¹⁵ / ₁₆
B042, B048, B060, C060	41

IMPORTANT:
Unit must be level to prevent water migration.

[] Designates Metric Conversions

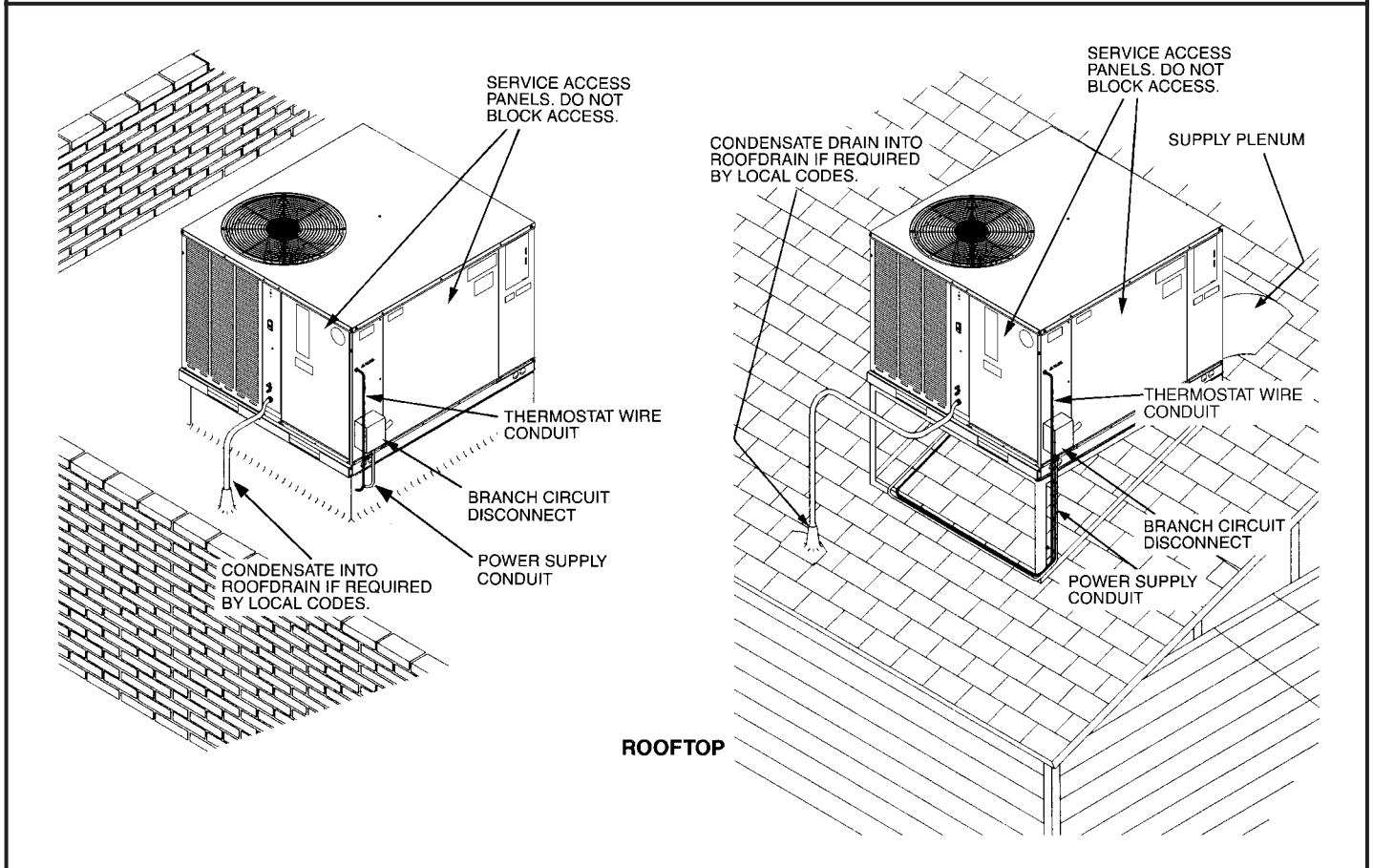
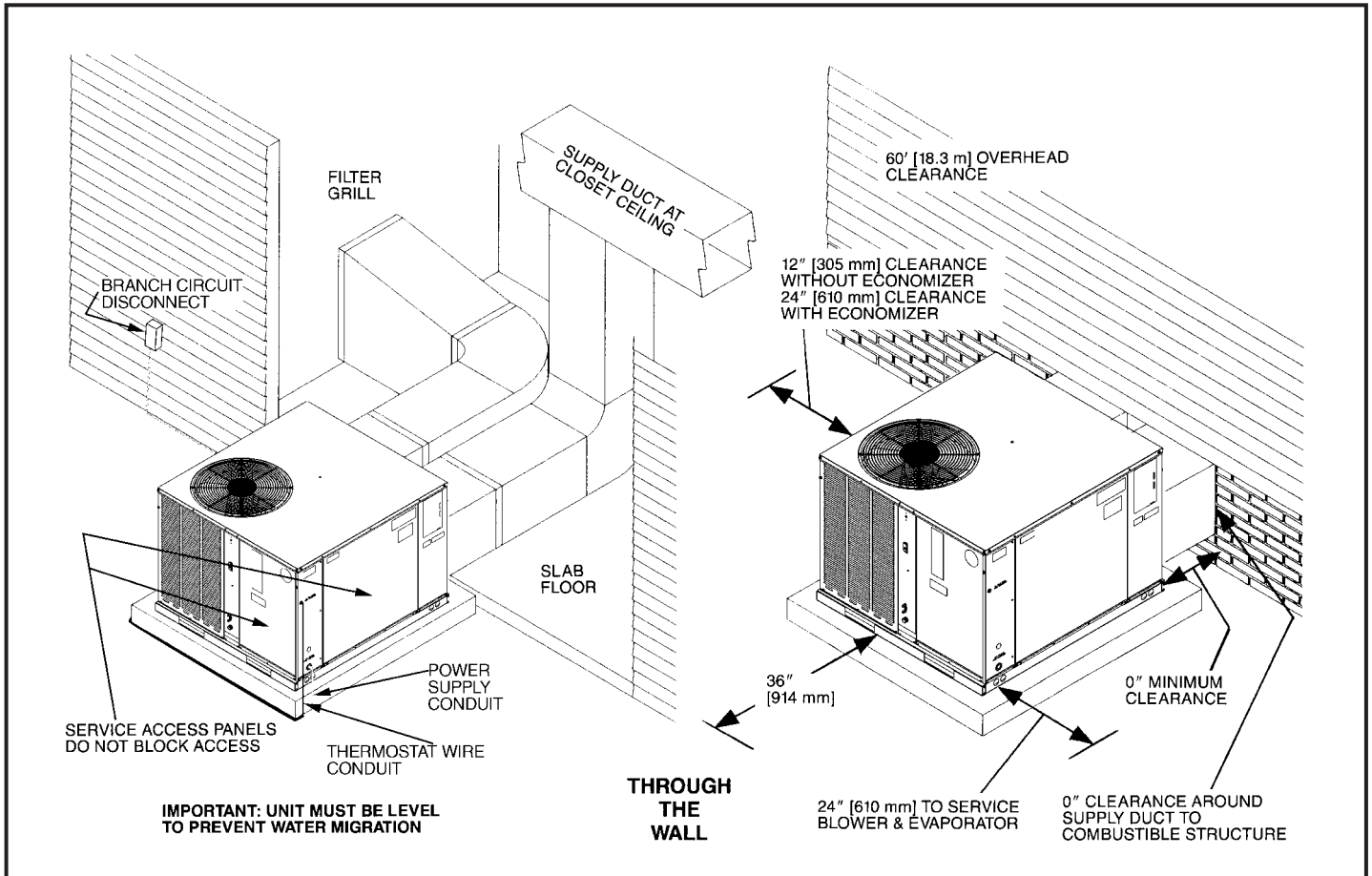

ACCESSORY EQUIPMENT

Accessory Description	Model Application	Accessory Model No.
Thermostats	RSNL-/RSPL-	See Thermostat Specification Sheet (T11-001)
Roofcurbs	RSNL-/RSPL-	RXSG-AAA08 (8" [203 mm] Height) RXSG-AAA14 (14" [356 mm] Height) RXSG-AAA24 (24" [610 mm] Height)
Supply & Return Diffusers	RSNL-/RSPL-	RXRN-D15
Economizers (Sideflow ONLY)	RSNL-/RSPL-	RXRE-CCA30 (3 Position) RXRD-CCM10 (Fully Modulating)
Economizers (Downflow ONLY)	RSNL-/RSPL-	RXRE-CAA30 (3 Position) RXRD-CAM10 (Fully Modulating)
Fresh Air Damper	RSNL-/RSPL-	RXRF-FAB1 (Motorized-35%) RXRF-FAA1 (Fixed-35%)
Rectangular to Round Transition (Downflow)	RSNL-/RSPL-	RXMC-CA02 (16" [406 mm] Ducts) RXMC-CA03 (18" [457 mm] Ducts)
Filter Kit	RSNL-/RSPL-	RXRY-01
Sideflow Rectangular to Round Transition	RSNL-/RSPL-	RXMC-A01
Low Ambient Control	RSNL-/RSPL-	RXRZ-01
High Pressure Control	RSNL-/RSPL-	RXAB-E01
Low Pressure Control	RSNL-/RSPL-	RXAC-C01

[] Designates Metric Conversions

COMMON SUPPLY/RETURN CONCENTRIC AIR DIFFUSER

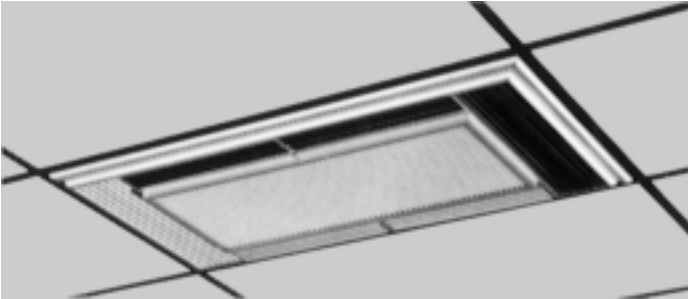

DIFFUSER INSTALLS FLUSH WITH CEILING

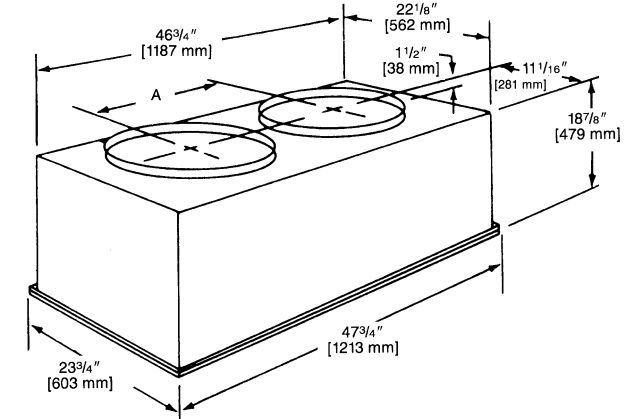

NOTE: The location of the combination supply and return diffuser should not exceed 10 feet [3.05 m] above the floor level for units @ 1000 CFM [472 L/s] or less and 12 [3.66 m] to 14 feet [4.27 m] above the floor level for units with CFM greater than 1000 [472 L/s]. If the diffuser is installed with a greater distance than recommended above, the supply air may become stratified above the required comfort area causing uncomfortable conditions.

AIRFLOW/PRESSURE DROP INFORMATION (INCHES W.C. [kPa])

Accessory	Approximate CFM [L/s]-Supply Air			
	1300 [614]	1575 [743]	1800 [850]	2200 [1038]
Plenum & Supply/Return Duct	.07 [.017]	.10 [.024]	.12 [.030]	.17 [.042]
Diffuser	.09 [.022]	.13 [.032]	.16 [.040]	.24 [.060]
Economizer	.06 [.015]	.09 [.022]	.11 [.027]	.17 [.042]

SUPPLY AIR/PERFORMANCE

Diffuser Airflow CFM [L/s]	Range of Throw Ft. [m]
800 [378]-1200 [566]	14 [4.27]-16 [4.88]
1600 [755]-2000 [944]	18 [5.49]-28 [8.53]

SUPPLY/RETURN DIFFUSER

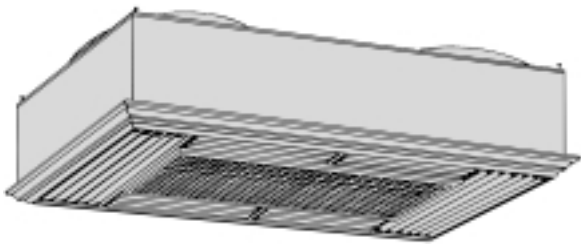

Designed to convert a side by side or an over and under arrangement into a concentric distribution of air. The diffuser is flush mounted, completely insulated, assembled, and internally baffled to provide four way supply air distribution with a center return. To make the assembly complete and ready to fit into a 2' [0.61 m] x 4' [1.22 m] suspended ceiling grid, the diffuser includes adjustable supply louvers, hanging rings, anti-sweat gasket, and round flanges for use with flexible ducts.

Model No.	Diameter Inches [mm]	Shipping Wt. Lbs. [kg]	Dimension A Inches [mm]
RXRN-BD15	16 [406]	90 [40.82]	20 1/2 [521]

FILTER KIT INSTALLATION RXRY-01

For use in either vertical
or horizontal discharge.

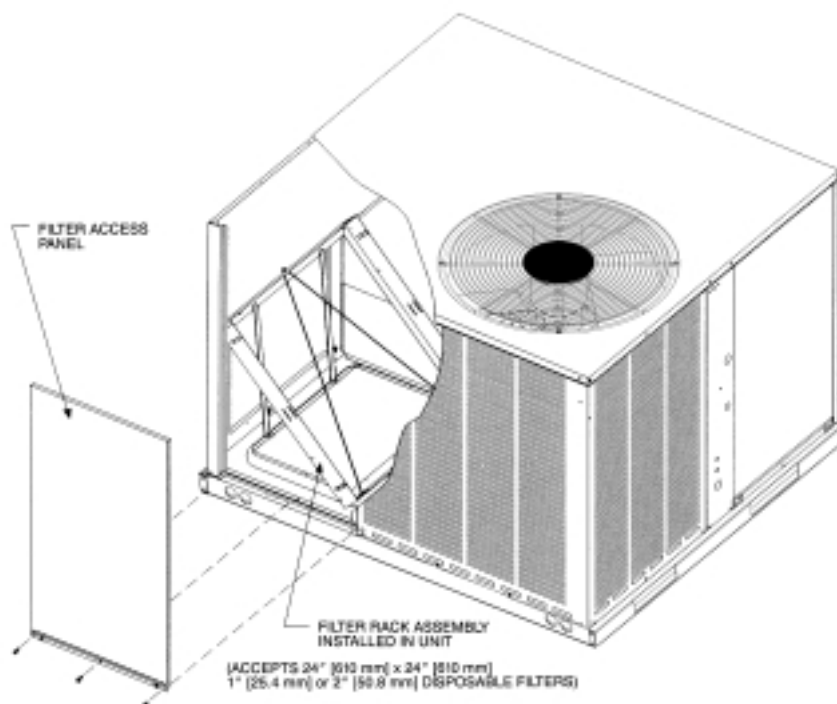

Airflow Pressure Drop, Inches W.C. [kPa]		
CFM [L/s]	1" Filter	2" Filter
500 [236]	.02 [.0050]	.03 [.0075]
600 [283]	.02 [.0050]	.03 [.0075]
700 [330]	.03 [.0075]	.04 [.0101]
800 [378]	.04 [.0101]	.05 [.0124]
900 [425]	.05 [.0124]	.06 [.0149]
1000 [472]	.07 [.0174]	.08 [.0199]
1100 [519]	.08 [.0199]	.09 [.0224]
1200 [566]	.10 [.0249]	.12 [.0299]
1300 [614]	.13 [.0324]	.15 [.0373]
1400 [661]	.16 [.0398]	.19 [.0473]
1500 [708]	.19 [.0473]	.21 [.0523]
1600 [755]	.20 [.0498]	.23 [.0572]
1700 [802]	.21 [.0523]	.24 [.0598]
1800 [850]	.22 [.0548]	.25 [.0623]
1900 [897]	.24 [.0598]	.27 [.0672]
2000 [944]	.26 [.0647]	.29 [.0722]

[] Designates Metric Conversions

DUCT ADAPTERS RECTANGULAR TO ROUND TRANSITIONS (DOWNFLOW)

RXMC-CA02

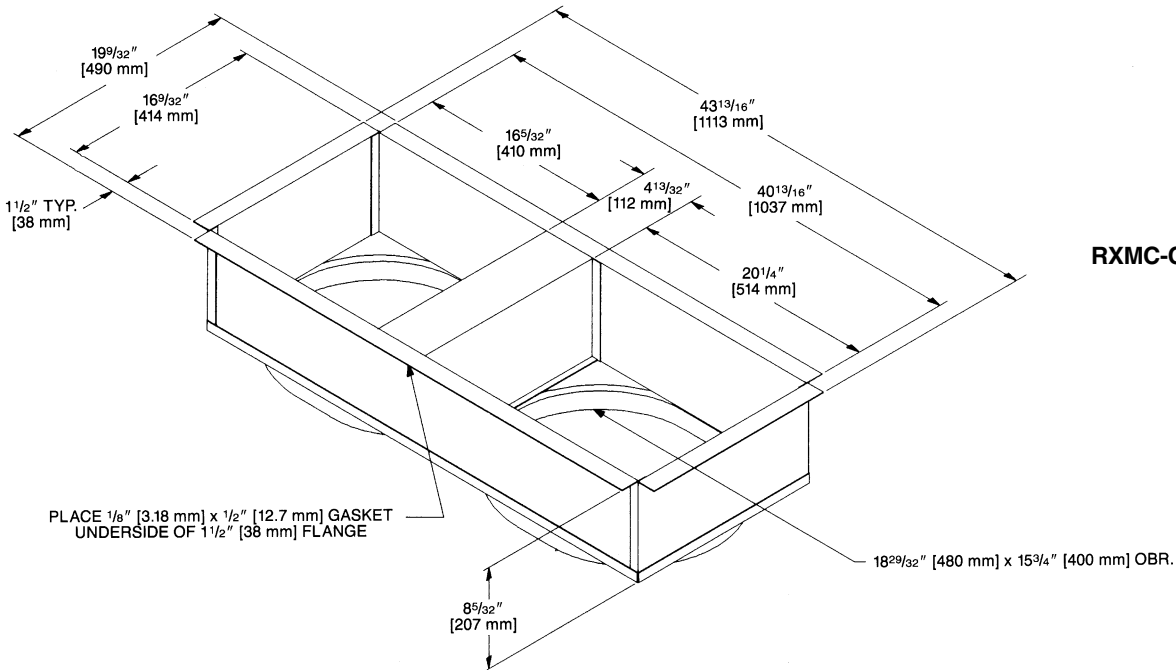
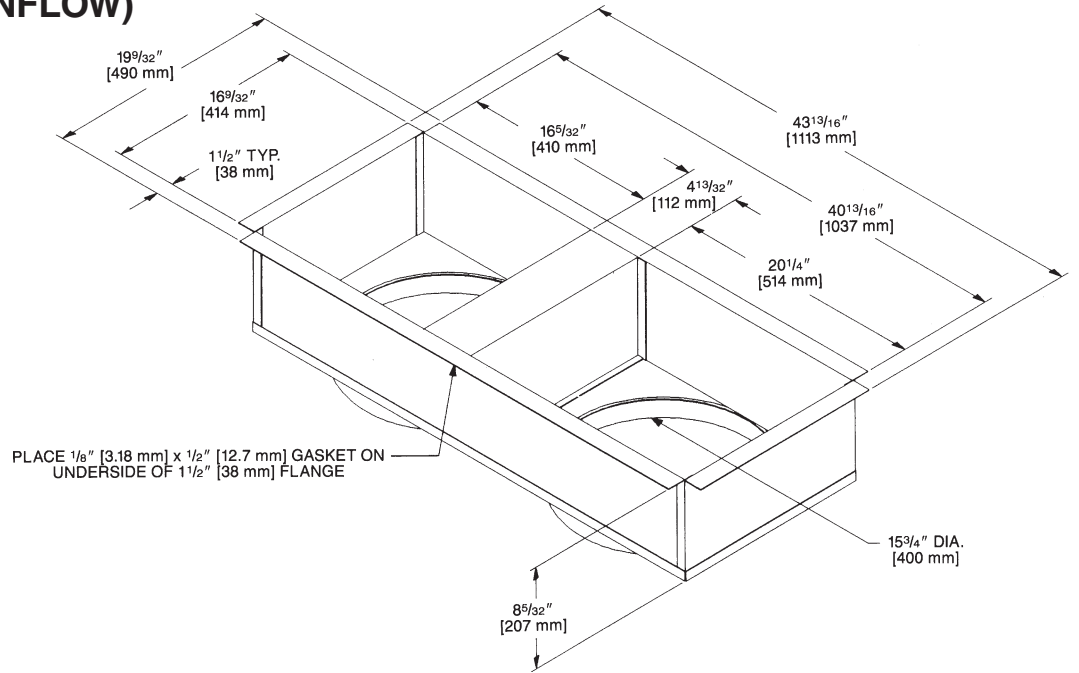

RXMC-CA03

[] Designates Metric Conversions

FRESH AIR DAMPER FOR USE ON RSNL-/RSPL- SERIES

RXRF-FAA1 (Fixed - 0-35%)

The 0-35% manual outside Air Damper is designed to replace the unit return air duct cover. No drilling or damper assembly is required. The amount of outside air (0-35%) is controlled by simply adjusting the side damper.

RXRF-FAB1 (Motorized - 0-35%)

The 0-35% motorized outside Air Damper is designed to replace the unit return air duct cover. No drilling or damper assembly is required. The control motor opens the adjustable slide damper when the unit blower motor is energized.

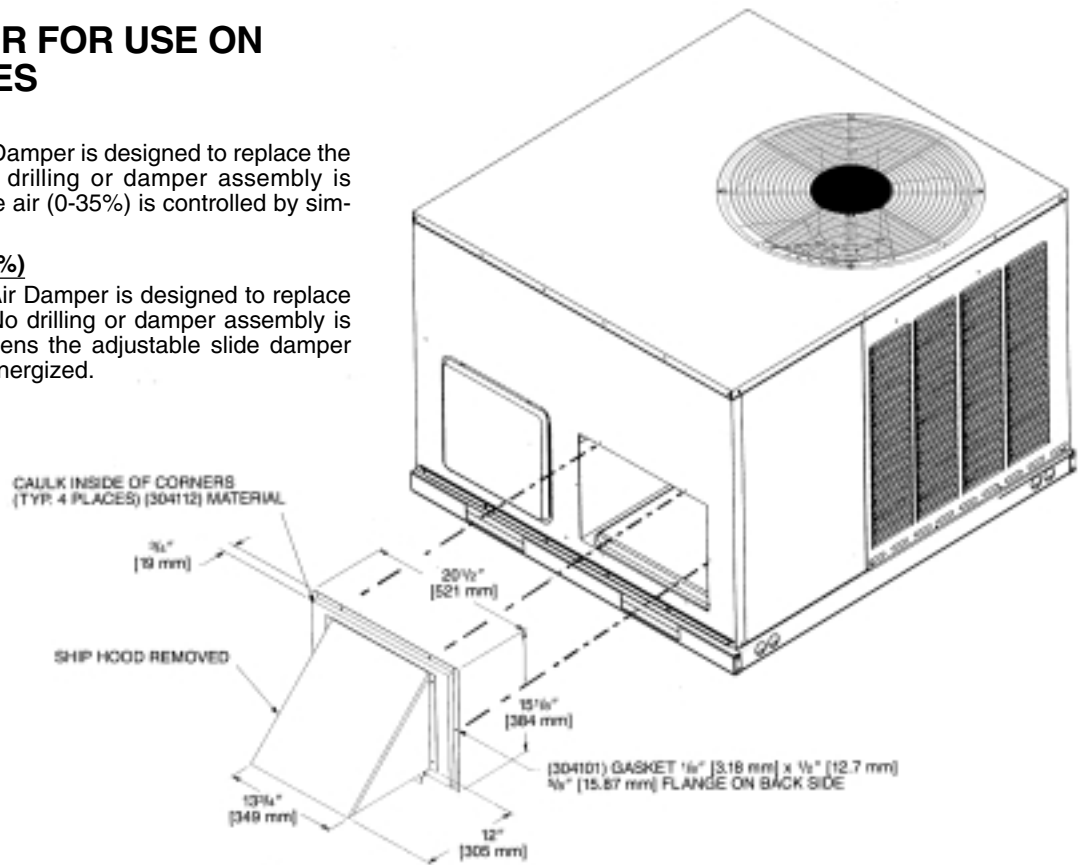

ECONOMIZERS

RXRE-CAA30 (3 Position) and RXRD-CAM10 (Fully Modulating)

RXRE-CAA30 (3 Position)

Provided with enthalpy control, and mixed air sensor. Settings include fully open, fully closed and adjustable mid point.

RXRD-CAM10 (Fully Modulating)

Provided with enthalpy control, mixed air sensor and minimum position potentiometer for proportioning (modulating) the amount of fresh air.

Note: See economizer installation instructions for correct filter access door.

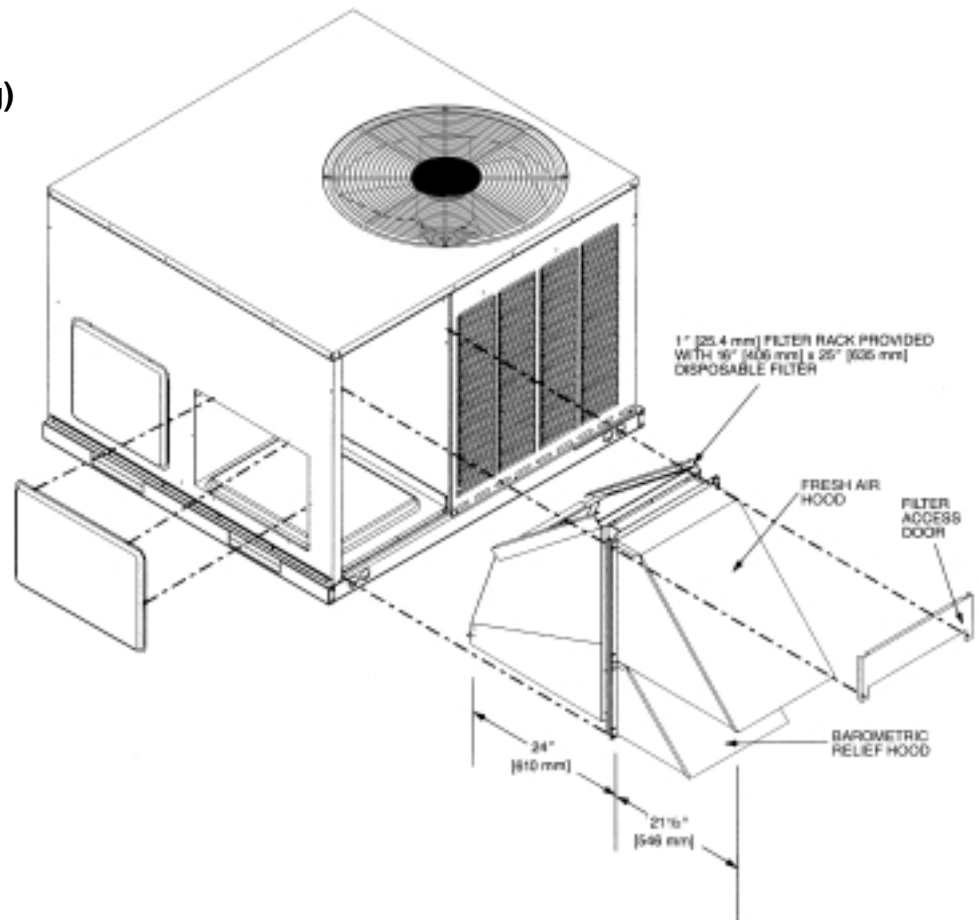

[] Designates Metric Conversions

ECONOMIZERS

RXRE-CAA30 (3 Position) and RXRD-CCM10 (Fully Modulating) for Horizontal Application

RXRE-CAA30 (3 Position)

Has outdoor air sensor, minimum position potentiometer, and mixed air sensor to provide three damper positions.

RXRD-CCM10 (Fully Modulating)

Provided with enthalpy control, mixed air sensor and minimum position potentiometer for proportioning (modulating) the amount of fresh air.

[] Designates Metric Conversions

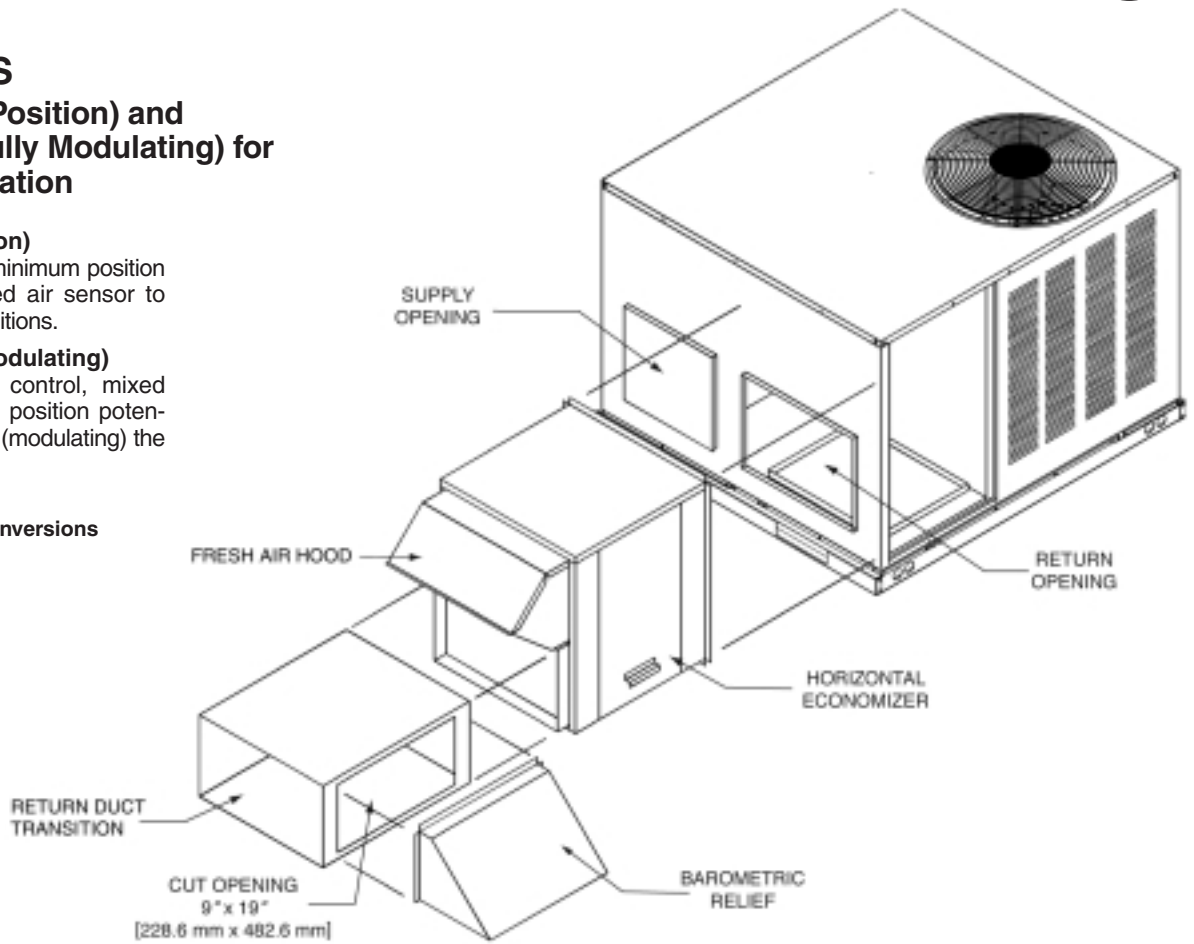

THERMOSTATS

Thermostats

THERMOSTATS



100-Series *
Non-Programmable



200-Series *
Programmable



300-Series *
Deluxe Programmable

400-Series * Special Applications/Programmable

500-Series *
Communicating/Programmable

Brand	Unique Model Number Prefix	Descriptor (3 Characters)	Series (3 Characters)	System (2 Characters)	Type (2 Characters)
RHC	-	TST	101	GE	MS
RHC=Rheem		TST=Thermostat	100=Non-Programmable 200=Programmable 300=Deluxe Programmable 400=Special Applications/Programmable 500=Communicating/Programmable	GE=Gas/Oil/Electric HP=Heat Pump MD=Modulating Furnace DF=Dual Fuel UN=Universal AC/HP/GE CM=Communicating	SS=Single-Stage MS=Multi-Stage

* Photos are representative. Actual models may vary.

For detailed thermostat match-up information, see specification sheet form number T11-001.

DUCT ADAPTER SIDEFLOW SQUARE TO ROUND TRANSITION RXMC-A01

Adapts the side rectangular supply and return openings to 14" [356 mm] diameter round openings. Adapters provided with same finish as unit and also provided with thermal insulation.

[] Designates Metric Conversions

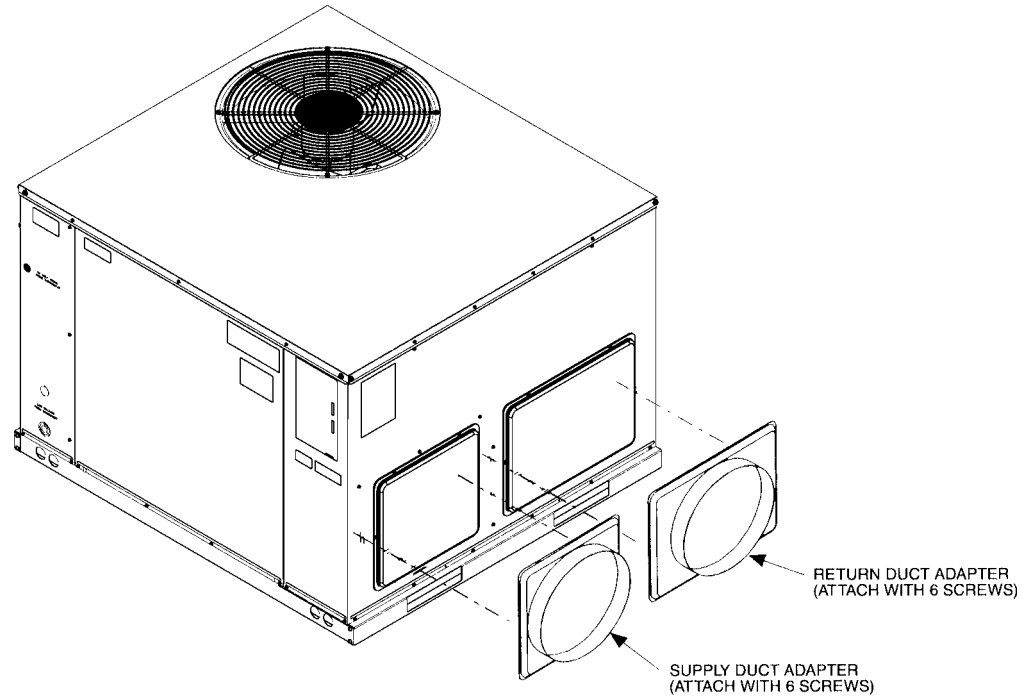

ROOFCURB (Full Perimeter) RXSG-AAA08, RXSG-AAA14 and RXSG-AAA24 for RSNL-/RSPL- Series

Hinged corners make for fast, easy set-up.

RXSG-AAA08
(8" [203 mm] High)

NOT for use with RQKA/RQLA/RQMA Package Heat Pumps.

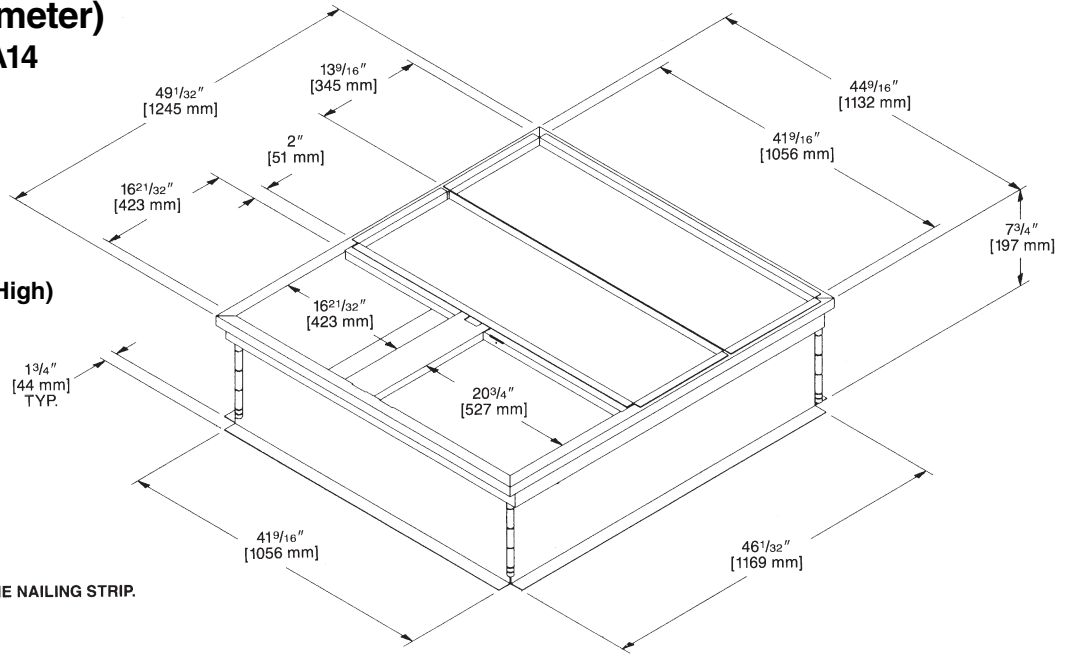

NOTE: PERIMETER OF ROOFCURB IS SUPPLIED WITH A NOMINAL 1" [25.4 mm] x 4" [102 mm] PINE NAILING STRIP.

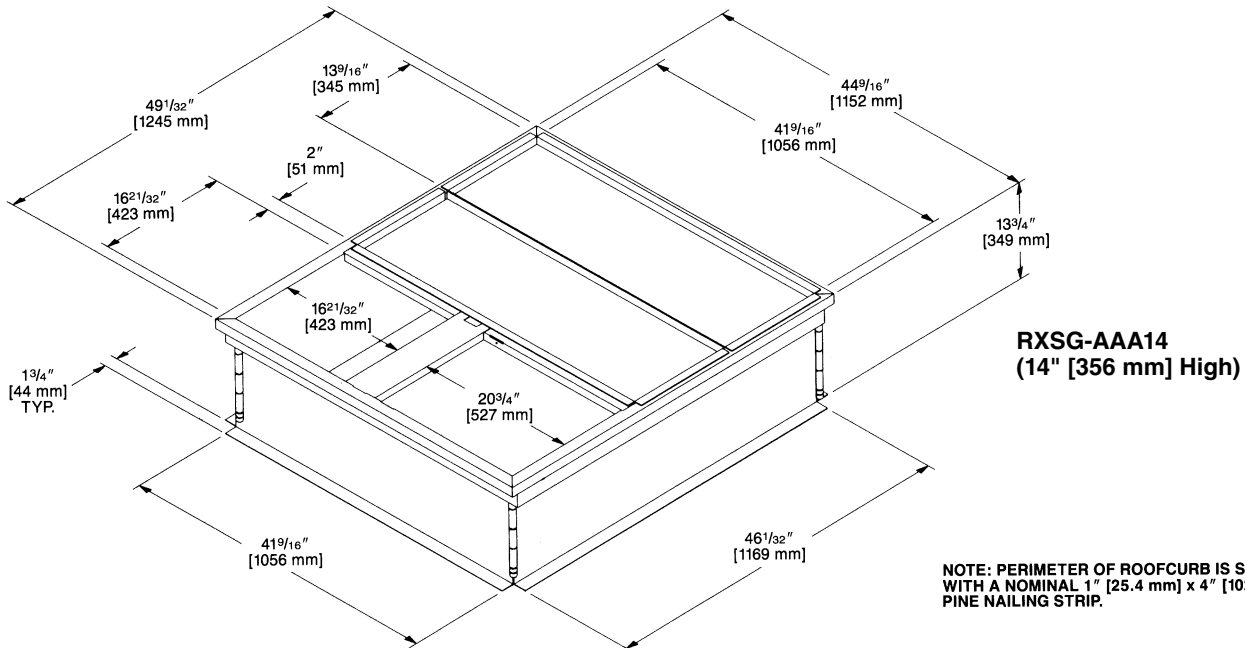

RXSG-AAA14
(14" [356 mm] High)

NOTE: PERIMETER OF ROOFCURB IS SUPPLIED WITH A NOMINAL 1" [25.4 mm] x 4" [102 mm] PINE NAILING STRIP.

[] Designates Metric Conversions

ROOFCURB (Full Perimeter) (Cont.)

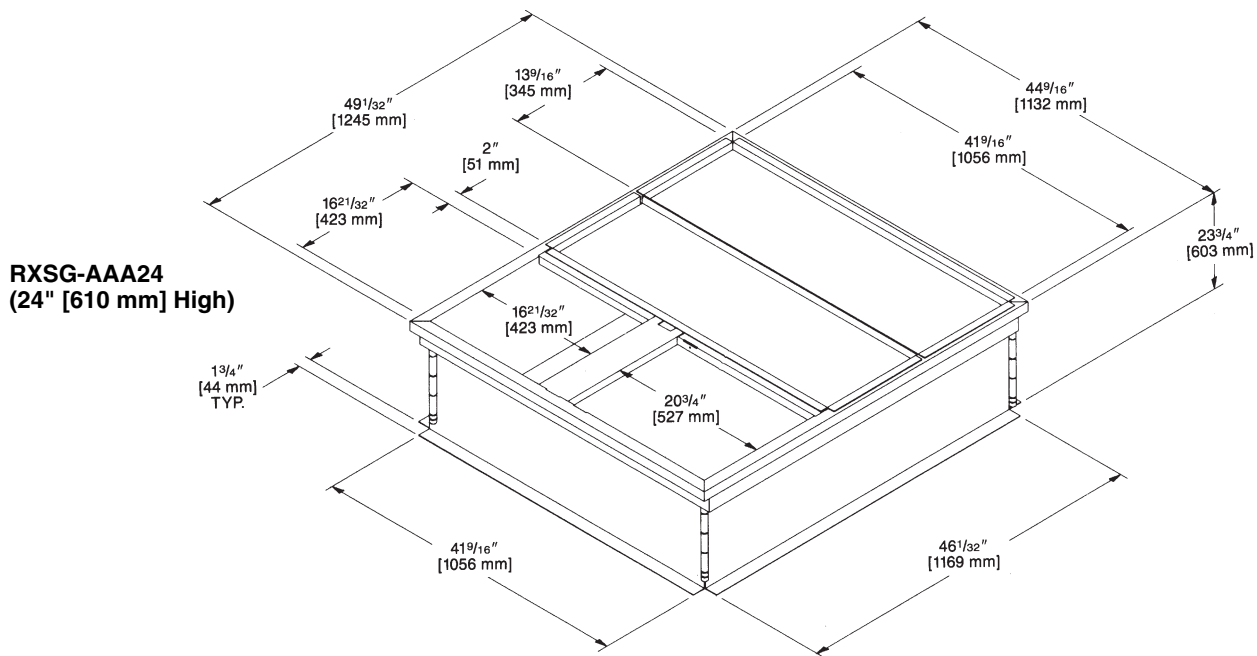

[] Designates Metric Conversions

PACKAGE AIR CONDITIONERS & GAS/ELECTRIC PACKAGE UNITS ROOFCURB INSTALLATION (Full Perimeter)

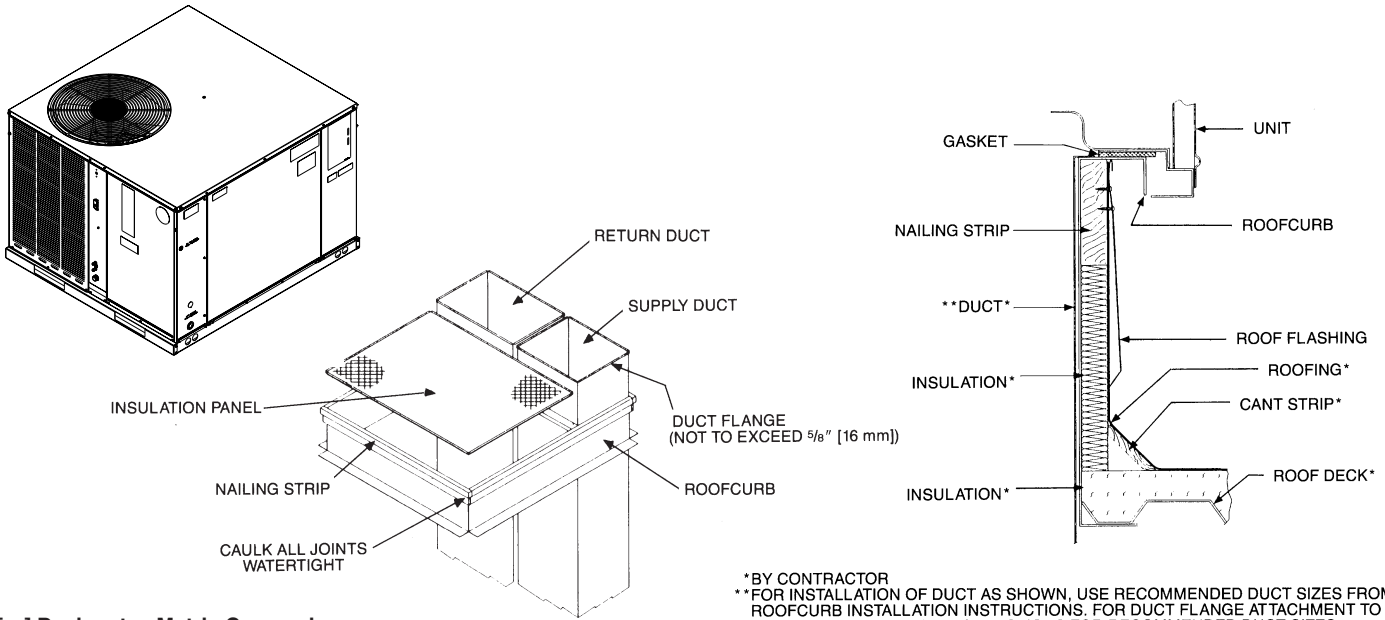

*BY CONTRACTOR
**FOR INSTALLATION OF DUCT AS SHOWN, USE RECOMMENDED DUCT SIZES FROM ROOFCURB INSTALLATION INSTRUCTIONS. FOR DUCT FLANGE ATTACHMENT TO UNIT, SEE UNIT INSTALLATION INSTRUCTIONS FOR RECOMMENDED DUCT SIZES.

[] Designates Metric Conversions

ROOFCURB ADAPTERS

Fabricated from galvanized steel to adapt the New cabinet to the old style curb. All are furnished with a New gasket.

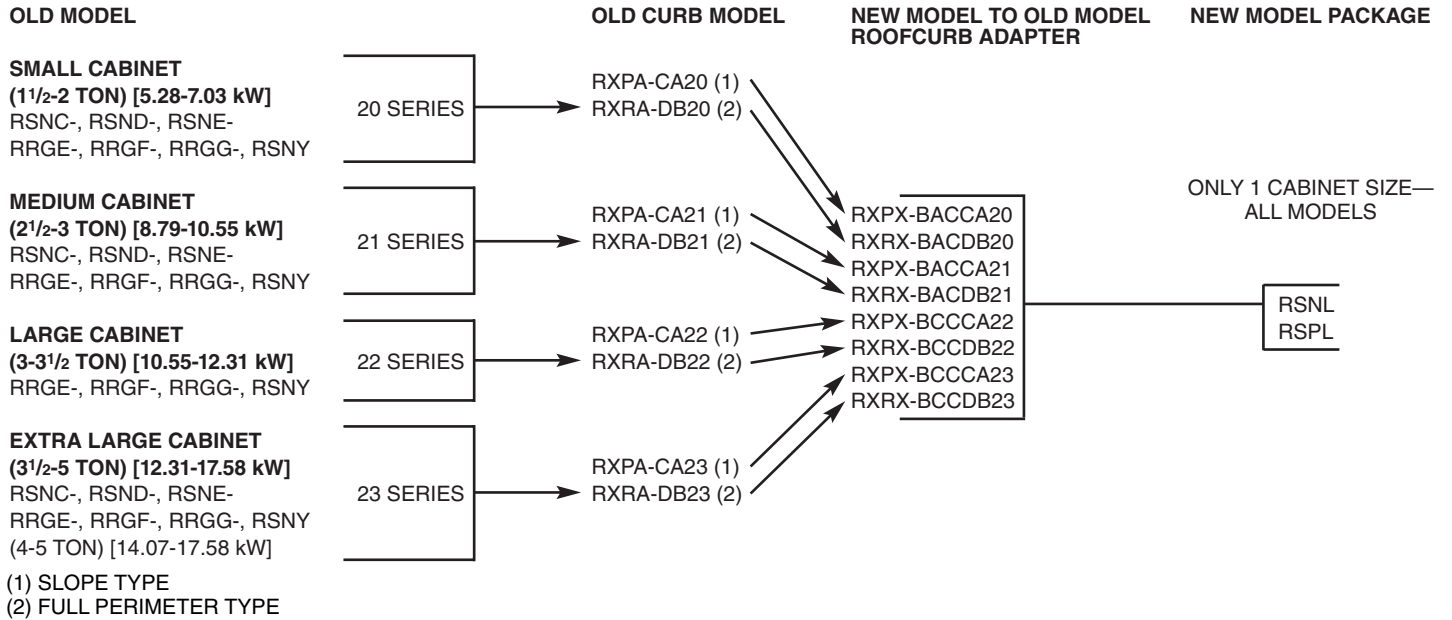



ELECTRIC HEATER KITS—RSNL-

Unit Model Application	Electric Heater Kit Models
RSNL/RSPL-B024JK	RXQJ-A05J (208-240 volt, 1-ph, 5kW)
	RXQJ-A10J (208-240 volt, 1-ph, 10kW)
RSNL/RSPL-B030JK	RXQJ-A05J (208-240 volt, 1-ph, 5kW)
	RXQJ-A10J (208-240 volt, 1-ph, 10kW)
RSNL/RSPL-B036JK	RXQJ-A10J (208-240 volt, 1-ph, 10kW)
	RXQJ-A15J (208-240 volt, 1-ph, 15kW)
RSNL/RSPL-B042JK	RXQJ-A10J (208-240 volt, 1-ph, 10kW)
	RXQJ-A15J (208-240 volt, 1-ph, 15kW)
RSNL/RSPL-B048JK, RSPL-B060JK/RJNL-C060JK	RXQJ-B10J (208-240 volt, 1-ph, 10kW)
	RXQJ-B15J (208-240 volt, 1-ph, 15kW)
RSNL/RSPL-B036CK	RXQJ-A10C (208-240 volt, 3-ph, 10kW)
	RXQJ-A15C (208-240 volt, 3-ph, 15kW)
RSNL/RSPL-B042CK	RXQJ-A10C (208-240 volt, 3-ph, 10kW)
	RXQJ-A15C (208-240 volt, 3-ph, 15kW)
RSNL/RSPL-B048CK, RSPL-B060CK/RSNL-C060JK	RXQJ-A10C (208-240 volt, 3-ph, 10kW)
	RXQJ-A15C (208-240 volt, 3-ph, 15kW)

[] Designates Metric Conversions

WARNING

ONLY ELECTRIC HEATER KITS SUPPLIED BY THIS MANUFACTURER AS DESCRIBED IN THIS PUBLICATION HAVE BEEN DESIGNED, TESTED, AND EVALUATED BY A NATIONALLY RECOGNIZED SAFETY TESTING AGENCY FOR USE WITH THIS UNIT. USE OF ANY OTHER MANUFACTURED ELECTRIC HEATERS INSTALLED WITHIN THIS UNIT MAY CAUSE HAZARDOUS CONDITIONS RESULTING IN PROPERTY DAMAGE, FIRE, BODILY INJURY OR DEATH.

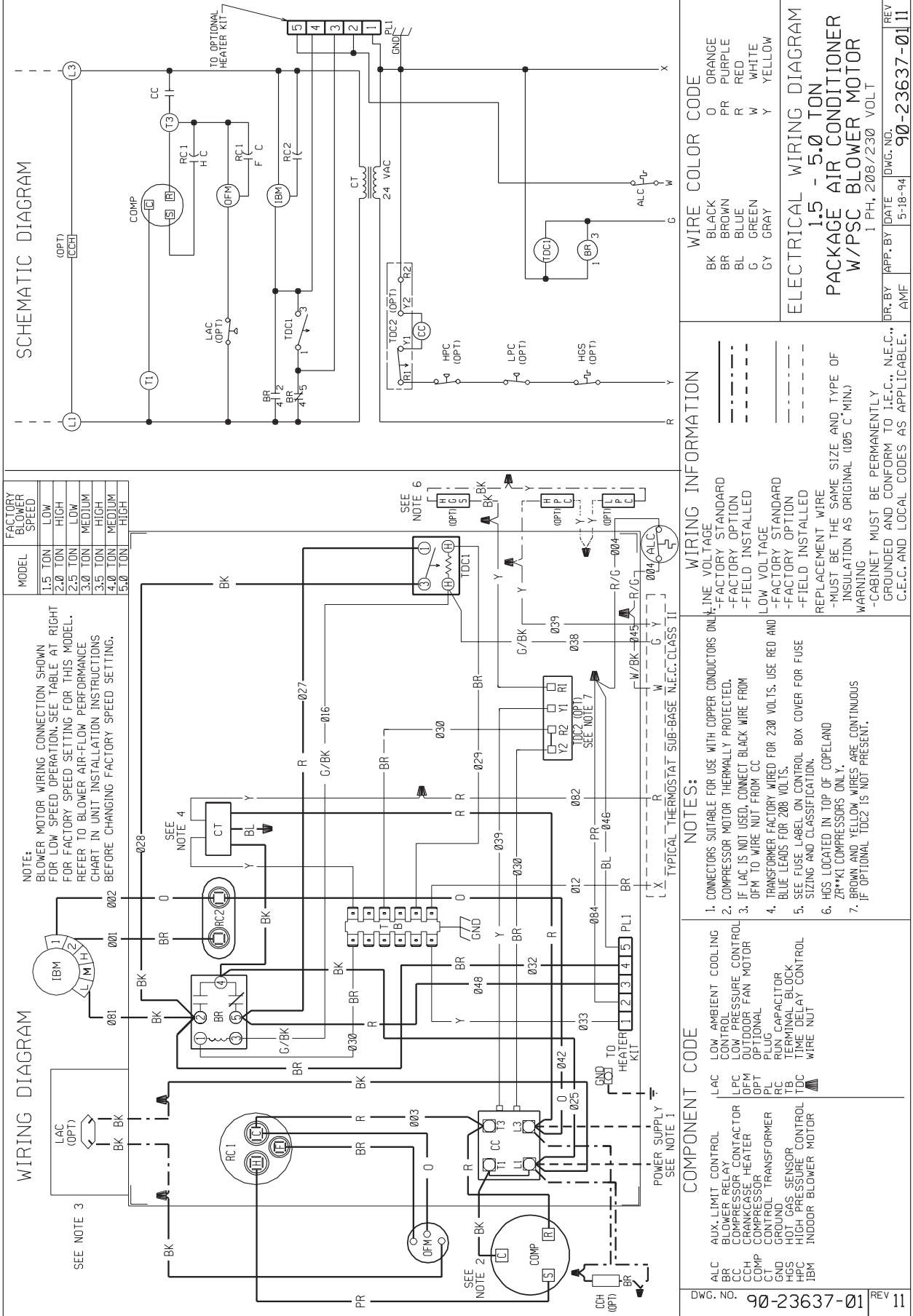

SCHEMATIC DIAGRAM

MODEL	FACTORY BLOWER SPEED
1.5 TON	LOW
2.0 TON	HIGH
2.5 TON	LOW
3.0 TON	MEDIUM
3.5 TON	HIGH
4.0 TON	MEDIUM
5.0 TON	HIGH

NOTE:
BLOWER MOTOR WIRING CONNECTION SHOWN FOR LOW SPEED OPERATION. SEE TABLE AT RIGHT FOR FACTORY SPEED SETTING FOR THIS MODEL. REFER TO BLOWER AIR-FLOW PERFORMANCE CHART IN UNIT INSTALLATION INSTRUCTIONS BEFORE CHANGING FACTORY SPEED SETTING.

WIRING DIAGRAM

WIRE COLOR CODE

BK	BLACK
BR	BROWN
BL	BLUE
G	GREEN
GY	GRAY
O	ORANGE
PR	PURPLE
R	RED
W	WHITE
Y	YELLOW

ELECTRICAL WIRING DIAGRAM
1.5 - 5.0 TON
PACKAGE AIR CONDITIONER
W/PSC BLOWER MOTOR
1 PH, 208/230 VOLT

DR. BY AMF
APP. BY DATE
DWG. NO. 90-23637-01
REV 11

WIRING INFORMATION

- LINE VOLTAGE
- FACTORY STANDARD
- FACTORY OPTION
- FIELD INSTALLED
- LOW VOLTAGE
- FACTORY STANDARD
- FACTORY OPTION
- FIELD INSTALLED
- REPLACEMENT WIRE
- MUST BE THE SAME SIZE AND TYPE OF INSULATION AS ORIGINAL (105 C° MIN.)
- WARNING: MUST BE PERMANENTLY GROUNDED AND CONFORM TO I.E.C., N.E.C., C.E.C. AND LOCAL CODES AS APPLICABLE.

NOTES:

- CONNECTORS SUITABLE FOR USE WITH COPPER CONDUCTORS ONLY
- COMPRESSOR MOTOR THERMALLY PROTECTED.
- IF LAC IS NOT USED, CONNECT BLACK WIRE FROM OFM TO WIRE NUT FROM CC
- TRANSFORMER FACTORY WIRING FOR 230 VOLTS. USE RED AND BLUE LEADS FOR 208 VOLTS.
- SEE FUSE LABEL ON CONTROL BOX COVER FOR FUSE SIZING AND CLASSIFICATION.
- HGS LOCATED IN TOP OF COPELAND
- ZR**KI COMPRESSORS ONLY.
- IF OPTIONAL TDC2 IS NOT PRESENT.

COMPONENT CODE

- ALC AUX. LIMIT CONTROL
- BR BLOWER RELAY
- CC COMPRESSOR CONTACTOR
- CLC COMPRESSOR HEATER
- CCMP COMPRESSOR
- CT CONTROL TRANSFORMER
- GND GROUND
- HGS HOT GAS SENSOR
- HPC HIGH PRESSURE CONTROL
- IBM INDOOR BLOWER MOTOR
- LAC LOW AMBIENT COOLING CONTROL
- LPC LOW PRESSURE CONTROL
- GFC LOW FLOW FAN MOTOR
- OPT OPTIONAL
- PLUG PLUG
- RC RUN CAPACITOR
- PC TERMINAL BLOCK
- TB TIME DELAY CONTROL
- TDC WIRE NUT

DWG. NO. 90-23637-01
REV 11

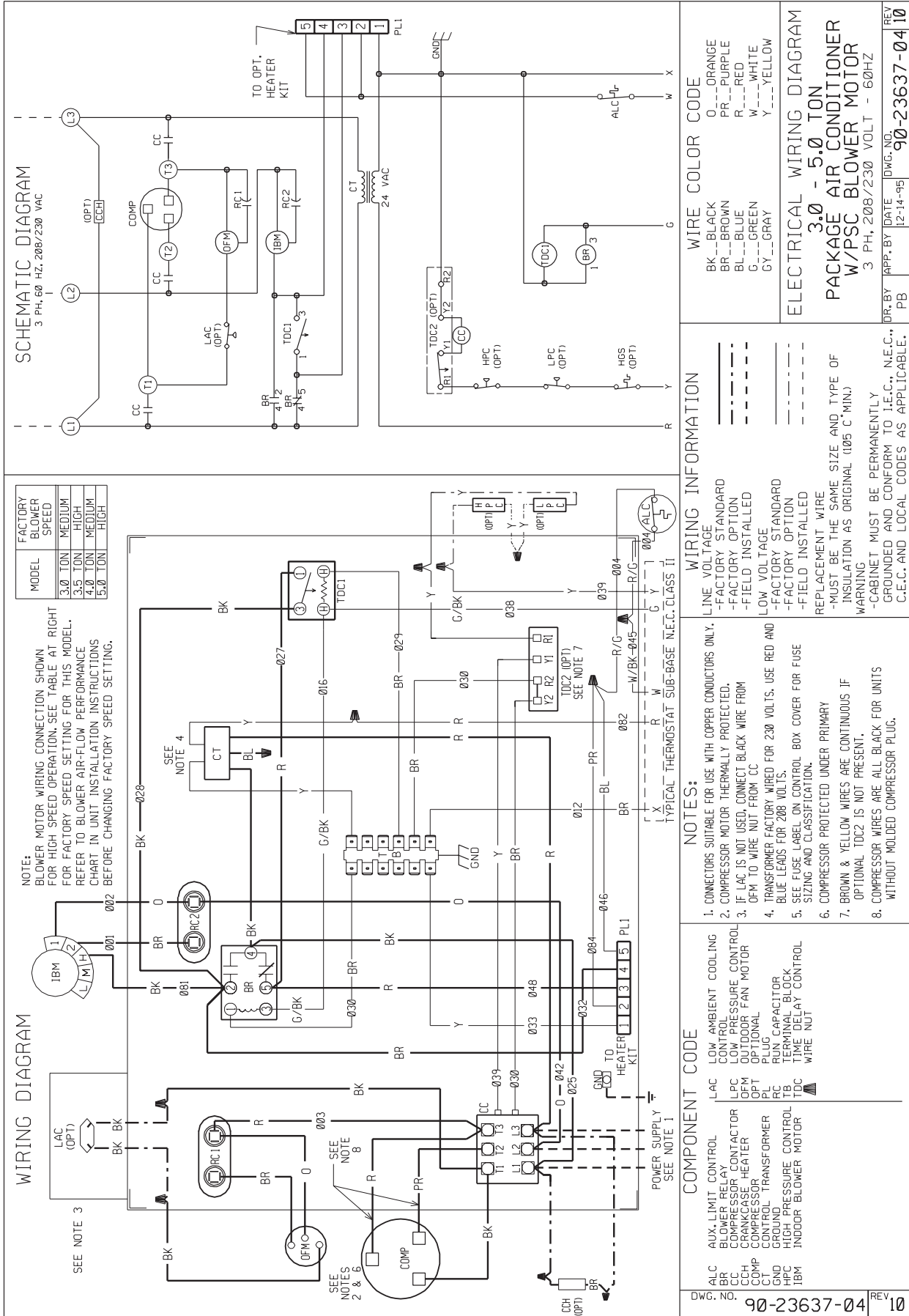

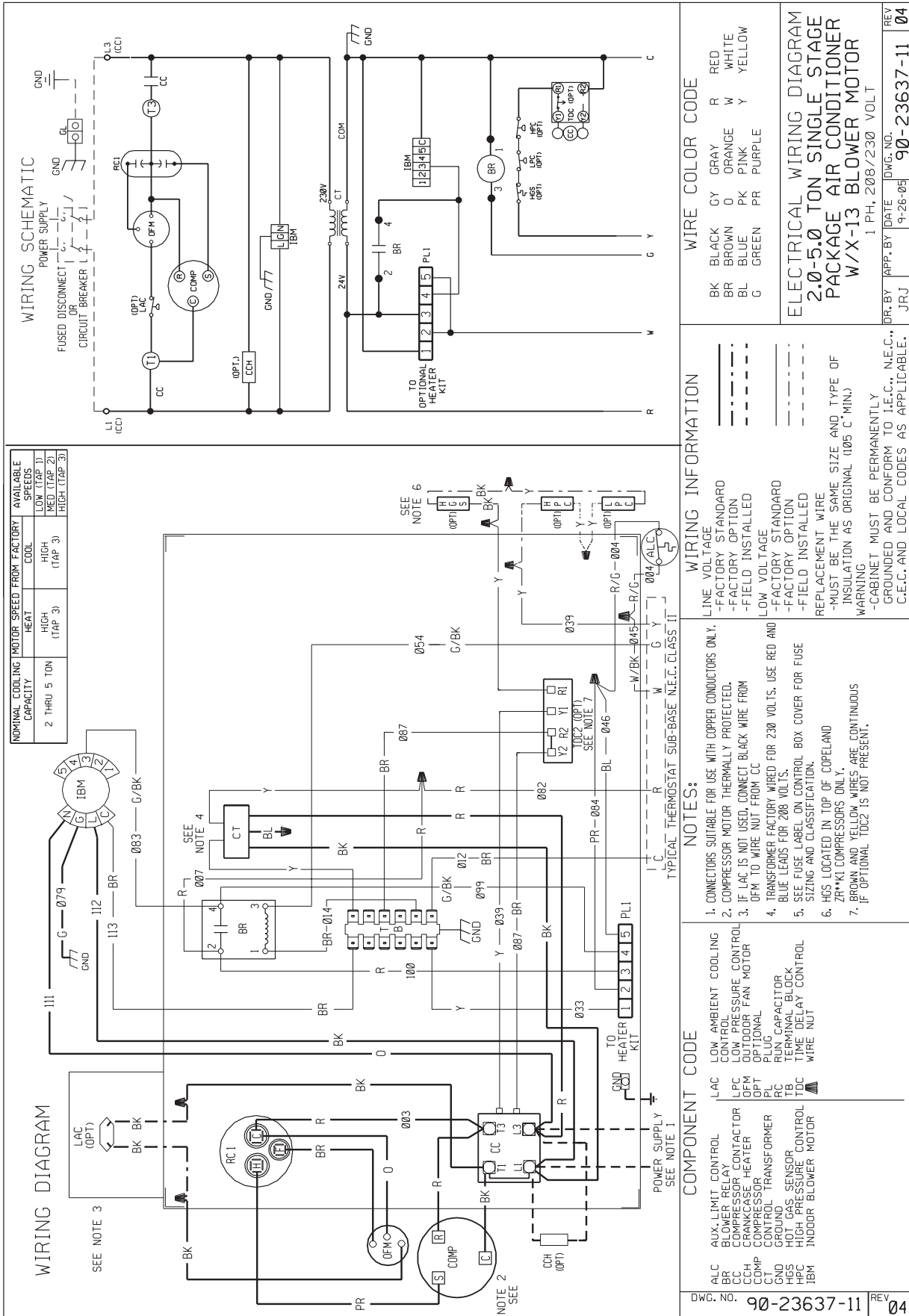

NOMINAL COOLING CAPACITY		MOTOR SPEED FROM FACTORY		AVAILABLE SPEEDS	
2 THRU 5 TON	HEAT (TAP 3)	HIGH (TAP 3)	COOL (TAP 3)	LOW (TAP 1)	HIGH (TAP 2)

WIRING SCHEMATIC

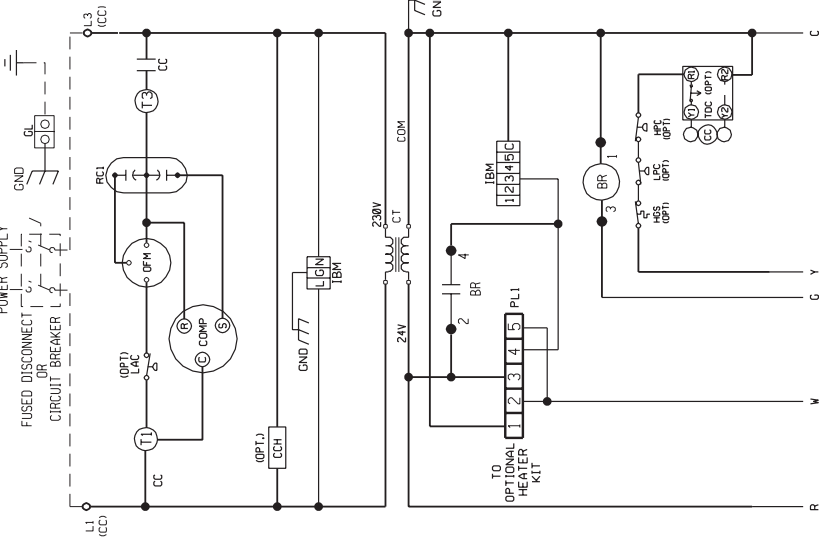

WIRE COLOR CODE	
BK	BLACK
BR	BROWN
BL	BLUE
G	GREEN
GY	GRAY
O	ORANGE
PK	PINK
PR	PURPLE
R	RED
W	WHITE
Y	YELLOW

WIRING INFORMATION	
---	LINE VOLTAGE
---	-FACTORY STANDARD
---	-FACTORY OPTION
---	-FIELD INSTALLED
---	LOW VOLTAGE
---	-FACTORY STANDARD
---	-FACTORY OPTION
---	-FIELD INSTALLED
---	REPLACEMENT WIRE
---	-MUST BE THE SAME SIZE AND TYPE OF INSULATION AS ORIGINAL (105 C MIN.)
---	WARNING
---	-CABINET MUST BE PERMANENTLY GROUNDED AND CONFORM TO I.E.C., N.E.C., C.E.C. AND LOCAL CODES AS APPLICABLE.

NOTES:	
1.	CONNECTORS SUITABLE FOR USE WITH COPPER CONDUCTORS ONLY.
2.	COMPRESSOR MOTOR THERMALLY PROTECTED.
3.	IF LAC IS NOT USED, CONNECT BLACK WIRE FROM OUTDOOR FAN MOTOR TO WIRE NUT FROM CC
4.	TRANSFORMER FACTORY WIRED FOR 230 VOLTS. USE RED AND BLUE LEADS FOR 208 VOLTS.
5.	SEE FUSE LABEL ON CONTROL BOX COVER FOR FUSE SIZING AND CLASSIFICATION.
6.	HGS LOCATED IN TOP OF COPELAND ZR**K1 COMPRESSORS ONLY.
7.	BROWN AND YELLOW WIRES ARE CONTINUOUS. IF OPTIONAL TDC2 IS NOT PRESENT.

COMPONENT CODE	
ALC	AUX LIMIT CONTROL
BLR	BLOWER RELAY
CC	COMPRESSOR CONTACTOR
CCCH	CRANKCASE HEATER
COMP	COMPRESSOR
CT	CONTROL TRANSFORMER
GRND	GROUND
GND	GROUND
HGS	HIGH GAS SENSOR
HPC	HIGH PRESSURE CONTROL
IBM	INDOOR BLOWER MOTOR
LAC	LOW AMBIENT COOLING CONTROL
LPC	LOW PRESSURE CONTROL
OFM	OUTDOOR FAN MOTOR
OPT	OPTIONAL
PL	PLUG
RC	RUN CAPACITOR
TB	TERMINAL BLOCK
TDC	TIME DELAY CONTROL
TDC	WIRE NUT

DWG. NO.	90-23637-11	REV	04
----------	-------------	-----	----

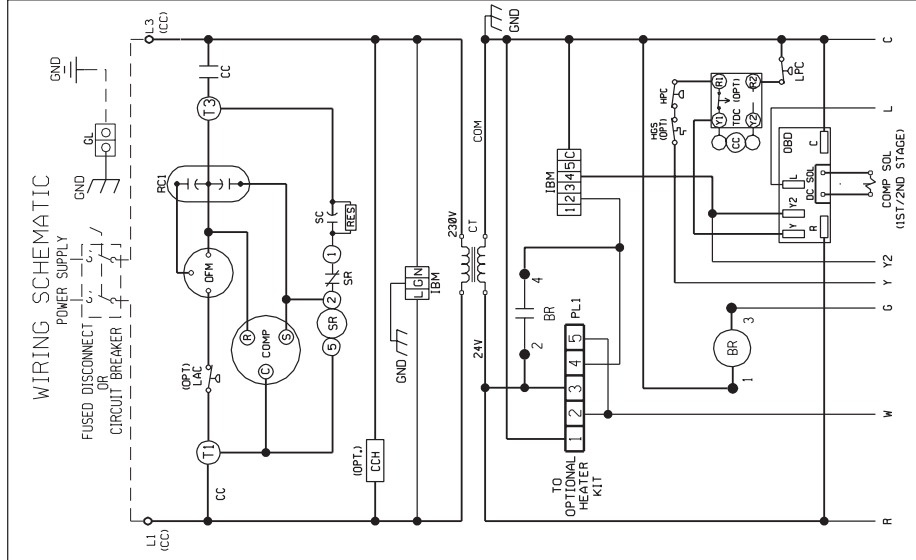
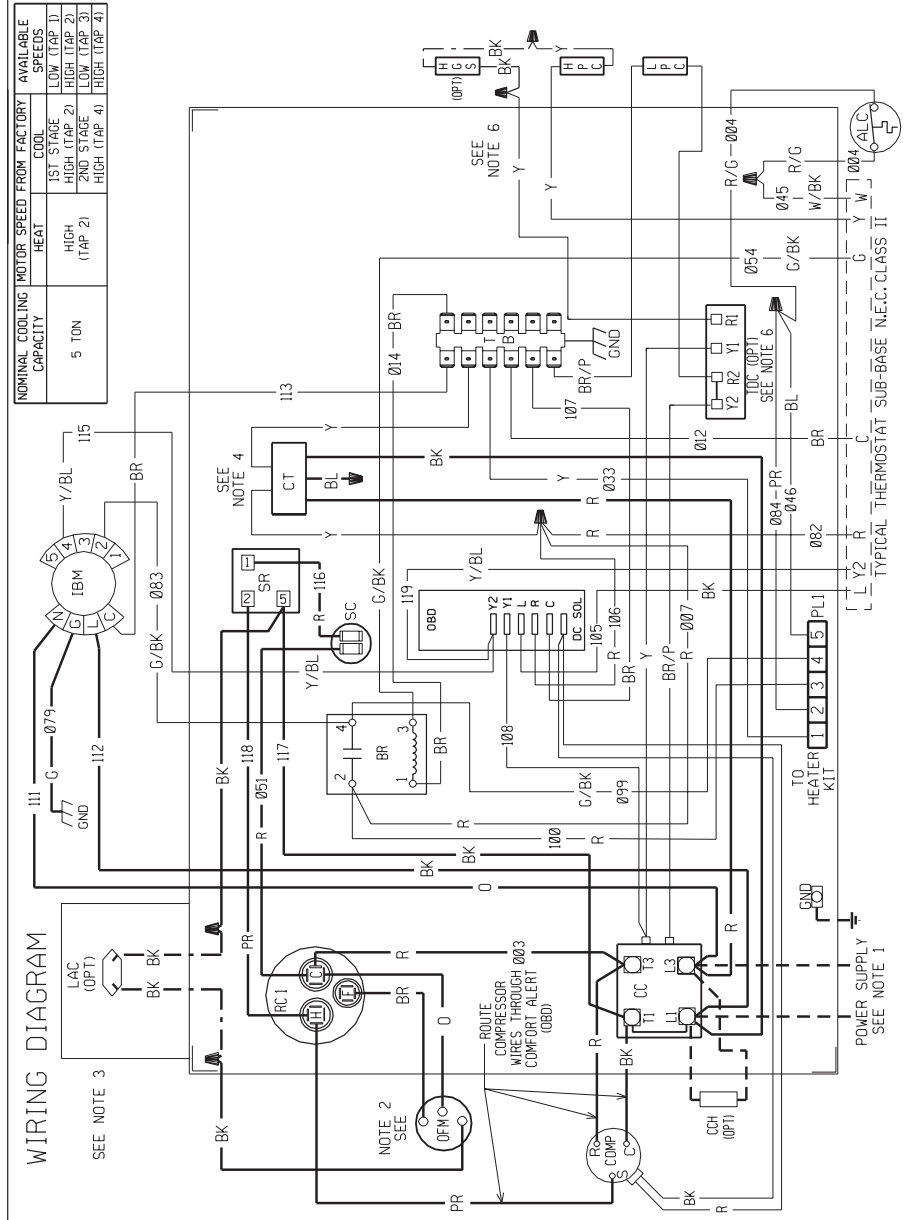

WIRE COLOR CODE

BK	BLACK	GY	GRAY	R	RED
BR	BROWN	O	ORANGE	W	WHITE
BL	BLUE	PK	PINK	Y	YELLOW
G	GREEN	PR	PURPLE		

ELECTRICAL WIRING DIAGRAM
PACKAGE AIR CONDITIONER
W/X-13 BLOWER MOTOR
 5.0 TON
 1 PH., 208/230 VOLT

WIRING INFORMATION

- LINE VOLTAGE
- FACTORY STANDARD
- FACTORY OPTION
- FIELD INSTALLED
- LOW VOLTAGE
- FACTORY STANDARD
- FIELD INSTALLED

REPLACEMENT WIRE
 -MUST BE THE SAME SIZE AND TYPE OF
 INSULATION AS ORIGINAL (105 C.MIN.)

WARNING
 -CABINET MUST BE PERMANENTLY
 GROUNDED AND CONFORM TO I.E.C., N.E.C.,
 C.E.C. AND LOCAL CODES AS APPLICABLE.

NOTES:

- CONNECTORS SUITABLE FOR USE WITH COPPER CONDUCTORS ONLY.
- COMPRESSOR MOTOR THERMALLY PROTECTED.
- IF LAC IS NOT USED, CONNECT BLACK WIRE FROM OUTDOOR FAN MOTOR TO WIRE NUT FROM CC
- TRANSFORMER FACTORY WIRE FOR 230 VOLTS. USE RED AND BLUE LEADS FOR 208 VOLTS.
- SEE FUSE LABEL ON CONTROL BOX COVER FOR FUSE SIZING AND CLASSIFICATION.
- BROWN AND YELLOW WIRES ARE CONTINUOUS. IF OPTIONAL LIMITS AND/OR TDC ARE NOT PRESENT.

COMPONENT CODE

ALC	AUX. LIMIT CONTROL
BR	BLOWER RELAY
CC	COMPRESSOR CONTACTOR
CCH	CRANKCASE HEATER
COMP	COMPRESSOR
CID	CONTROL TRANSFORMER
HCS	HOT GAS SENSOR
HPC	HIGH PRESSURE CONTROL
IBM	INDOOR BLOWER MOTOR
LAC	LOW AMBIENT COOLING CONTROL
LPC	LOW PRESSURE CONTROL
OBD	ON-BOARD DIAGNOSTICS
OFM	OUTDOOR FAN MOTOR
PLC	PLUG
RC	RUN CAPACITOR
SC	START CAPACITOR
SR	START RELAY
TB	TERMINAL BLOCK
TDC	TIME DELAY CONTROL
WRE NUT	WIRE NUT

DWG. NO. **90-23637-13** REV **06**

DR. BY **JRJ** APP. BY **JRJ** DATE **11-9-05** DWG. NO. **90-23637-13** REV **06**

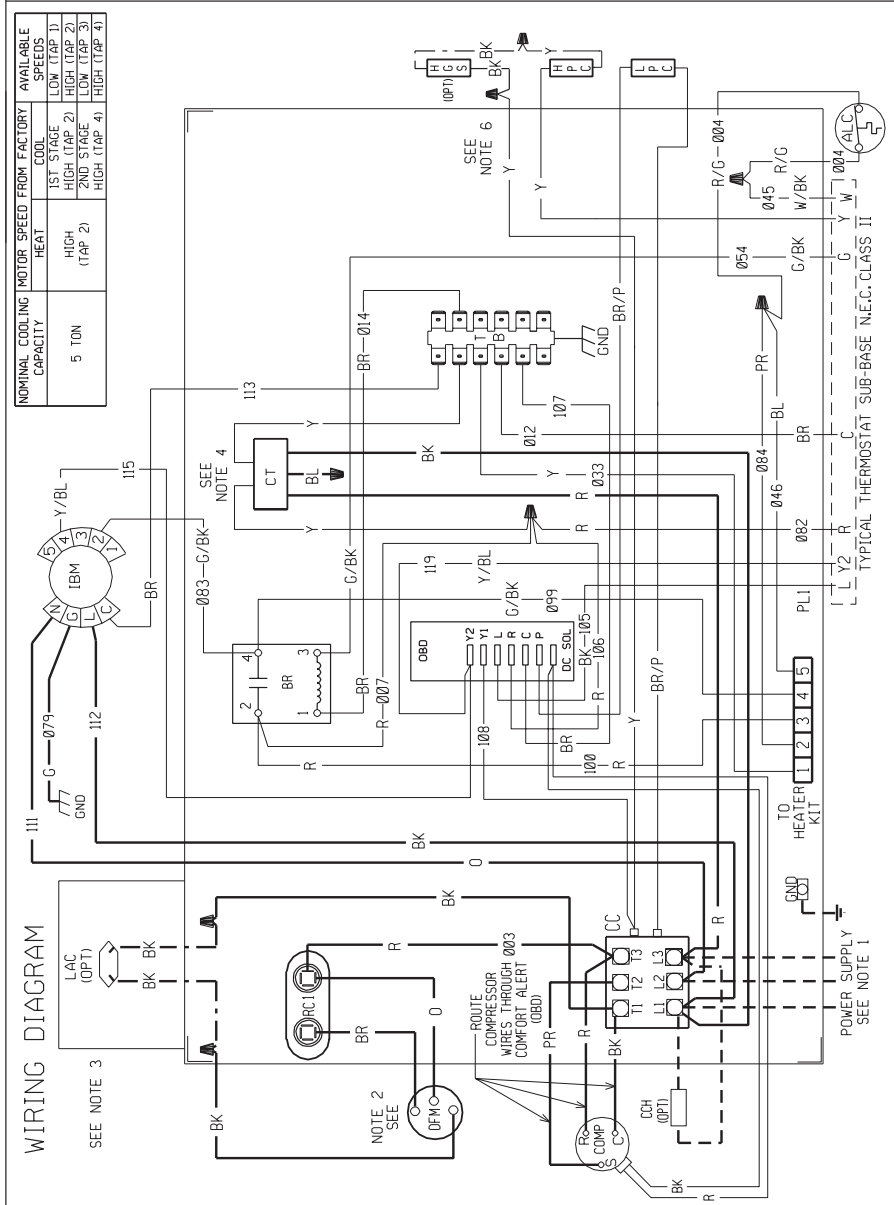
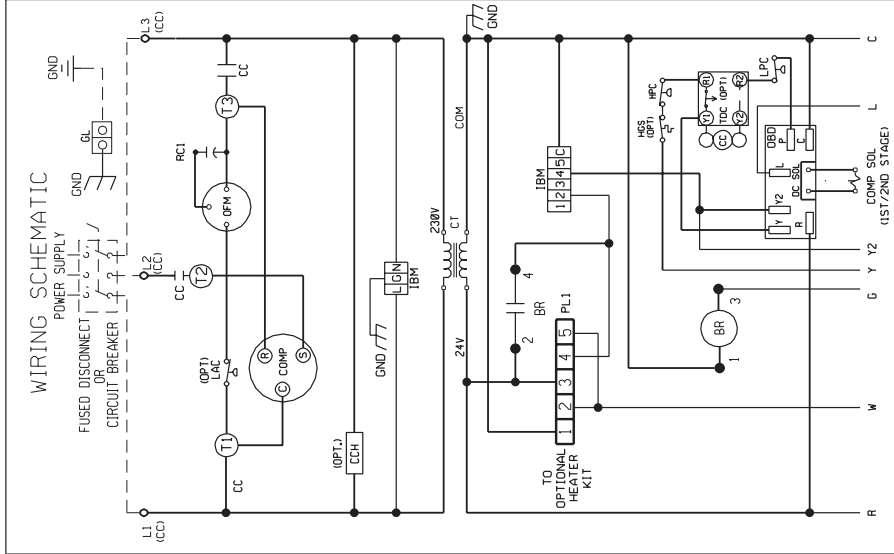

NOMINAL COOLING CAPACITY	MOTOR SPEED	FROM FACTORY	AVAILABLE SPEEDS
5 TON	HEAT	HIGH (TAP 2)	LOW (TAP 1)
		HIGH (TAP 2)	HIGH (TAP 2)
	COOL	HIGH (TAP 2)	LOW (TAP 1)
		HIGH (TAP 2)	HIGH (TAP 2)

WIRE COLOR CODE

BK	BLACK	GY	GRAY	R	RED
BR	BROWN	O	ORANGE	W	WHITE
BL	BLUE	PK	PINK	Y	YELLOW
G	GREEN	PR	PURPLE		

ELECTRICAL WIRING DIAGRAM
5.0 TON
PACKAGE AIR CONDITIONER
W/X-13 BLOWER MOTOR

DATE: 3 PH, 208/230 VOLT
DWG. NO. 90-23637-14
REV 06

WIRING INFORMATION

LINE VOLTAGE
-FACTORY STANDARD
-FACTORY OPTION
-FIELD INSTALLED

LOW VOLTAGE
-FACTORY STANDARD
-FACTORY OPTION
-FIELD INSTALLED

REPLACEMENT WIRE
-MUST BE THE SAME SIZE AND TYPE OF INSULATION AS ORIGINAL (105 C° MIN.)
-CABINET MUST BE PERMANENTLY GROUNDED AND CONFORM TO I.E.C., N.E.C., C.E.C. AND LOCAL CODES AS APPLICABLE.

- NOTES:**
- CONNECTORS SUITABLE FOR USE WITH COPPER CONDUCTORS ONLY.
 - COMPRESSOR MOTOR THERMALLY PROTECTED.
 - IF LAC IS NOT USED, CONNECT BLACK WIRE FROM OFM TO WIRE NUT FROM CC
 - TRANSFORMER FACTORY WIRED FOR 230 VOLTS. USE RED AND BLUE LEADS FOR 208 VOLTS.
 - SEE FUSE LABEL ON CONTROL BOX COVER FOR FUSE SIZING AND CLASSIFICATION.
 - BROWN AND YELLOW WIRES ARE CONTINUOUS. IF OPTIONAL LIMITS ARE NOT PRESENT.

COMPONENT CODE

ALC	AUX. LIMIT CONTROL
BR	BLOWER RELAY
CC	COMPRESSOR CONTACTOR
DFM	INDOOR FAN MOTOR
IBM	INDOOR BLOWER MOTOR
OPT	OPTIONAL
PL	PLUG
RC	RUN CAPACITOR
SC	START CAPACITOR
SR	START RELAY
TB	TERMINAL BLOCK
WIRE NUT	WIRE NUT

DWG. NO. 90-23637-14
REV 06

BEFORE PURCHASING THIS APPLIANCE, READ IMPORTANT ENERGY COST AND EFFICIENCY INFORMATION AVAILABLE FROM YOUR RETAILER.

GENERAL TERMS OF LIMITED WARRANTY

Rheem will furnish a replacement for any part of this product which fails in normal use and service within the applicable periods stated, in accordance with the terms of the limited warranty.

For Complete Details of the Limited Warranty, Including Applicable Terms and Conditions, See Your Local Installer or Contact the Manufacturer for a Copy.

Condenser Coil and Evaporator Coil leaks caused by factory defects	Five (5) Years
Compressor:	
1-Phase Models	
(Residential Applications)	Ten (10) Years
1 & 3-Phase Models	
(Commercial Applications)	Five (5) Years
Heating Elements	Five (5) Years
Any Other Part	
1-Phase Models	
(Residential Applications)	Five (5) Years
1 & 3-Phase Models	
(Commercial Applications)	One (1) Year

Before proceeding with installation, refer to installation instructions packaged with each model, as well as complying with all Federal, State, Provincial, and Local codes, regulations, and practices.

**Rheem Heating,
Cooling and
Water Heating**

P.O. Box 17010, Fort Smith, AR 72917



"In keeping with its policy of continuous progress and product improvement, Rheem reserves the right to make changes without notice."