



PHJ3

Product Specifications

13 SEER, R-410A

PACKAGE HEAT PUMP FOR MANUFACTURED HOUSING, RESIDENTIAL, AND LIGHT COMMERCIAL APPLICATIONS 2 – 5 TONS

Single Phase, 208/230 V, 60 Hz

BUILT TO LAST, EASY TO INSTALL AND SERVICE

- Compact, fully self-contained, electric cooling unit with horizontal supply and return ducts
- Light weight, compact construction ideal for manufactured housing and residential applications
- Environmentally sound R-410A refrigerant
- Vibration isolation provides quiet operation. Compressors have internal over current protection
- Liquid refrigerant filter driers
- Hand holds built into the unit base pan
- Designed to be serviced from both the side and front
- Accessory electric heaters with single point connections
- Durable pre-painted steel cabinet
- No-rust base pan with integrated drain pan standard on all units
- Direct-drive ECM multi-speed, blower motor standard on all models
- Louvered coil enclosure for protection against vandalism and hail damage
- Aerodynamic fan blade design reduces the overall sound
- All models available with optional factory installed tin-coated copper evaporator coil. (These models are identified with letters TP in the 11th and 12th positions in the model numbers)



LIMITED WARRANTY*

- 5-year parts limited warranty (including compressor and coils)
-With timely registration, an additional 5 year parts limited warranty (including compressor and coils)
- *Applies to original purchaser/homeowner, some limitations may apply. See warranty certificate for details.



Use of the AHRI Certified TM Mark indicates a manufacturer's participation in the program. For verification of certification for individual products, go to www.ahridirectory.org.



UNIT PERFORMANCE DATA

| Model Number | COOLING | | | HEATING | | Unit Dimensions H x W x D in [mm] | Operating Weight lbs [kg] |
|----------------------------------|-------------------|------|------|----------------------------|------|---------------------------------------|---------------------------------|
| | Capacity BTU/h | SEER | EER | NET HEATING CAPACITY | HSPF | | |
| PHJ324000K000A PHJ324000KTP0A | 24,000 | 13.5 | 11.5 | 23,800 | 7.7 | 30 [765]x51 [1295]x32 [813] | 263 [120] |
| PHJ330000K000A PHJ330000KTP0A | 28,800 | 13.5 | 11.5 | 28,600 | 7.7 | 30 [765]x51 [1295]x32 [813] | 264 [120] |
| PHJ336000K000A PHJ336000KTP0A | 36,000 | 13.5 | 11.5 | 34,400 | 7.7 | 34 [867]x51 [1295]x32 [813] | 285 [130] |
| PHJ342000K000A PHJ342000KTP0A | 41,500 | 13.5 | 11.5 | 41,000 | 7.7 | 42 [1070]x51 [1295]x32 [813] | 339 [154] |
| PHJ348000K000A PHJ348000KTP0A | 46,500 | 13.5 | 11.5 | 46,500 | 7.7 | 42 [1070]x51 [1295]x32 [813] | 358 [163] |
| PHJ360000K000A PHJ360000KTP0A | 55,000 | 13.0 | 11.0 | 55,000 | 7.7 | 42 [1070]x51 [1295]x32 [813] | 371 [169] |

| MODEL NOMENCLATURE | | | | | | | | | | |
|---------------------------------------|----------|-----------|----------|--------------------------|------------------------------|----------|---------------------------|----------|--------------|----------|
| MODEL SERIES | 1 | 2, 3 | 4 | 5,6 | 7,8,9 | 10 | 11,12 | 13 | 14 | 15 |
| | P | HJ | 3 | 36 | 000 | K | 00 | 0 | A | 1 |
| P = Package | | | | | | | | | | |
| HJ = Heat Pump | | | | | | | | | | |
| 3 = 13 | | | SEER | | | | | | | |
| 24 = 2 Tons | | | | | | | | | | |
| 30 = 2.5 Tons | | | | | | | | | | |
| 36 = 3 Tons | | | | | | | | | | |
| 42 = 3.5 Tons | | | | | | | | | | |
| 48 = 4 Tons | | | | | | | | | | |
| 60 = 5 Tons | | | | NOMINAL COOLING CAPACITY | | | | | | |
| 000 = no factory heat | | | | | NOMINAL HEATING BTUH (input) | | | | | |
| K = 208/230-1-60 | | | | | | VOLTAGE | | | | |
| 00 = No options | | | | | | | | | | |
| TP - Tin Plated Evaporator Main Tubes | | | | | | | FACTORY INSTALLED OPTIONS | | | |
| 0 = Standard | | | | | | | | | FEATURE CODE | |
| Sales Model Digit | | | | | | | | | | |
| Engineering Digit | | | | | | | | | | |

AHRI CAPACITY RATINGS – COOLING CAPACITIES AND EFFICIENCIES

| PHJ3 | NOMINAL TONS | STANDARD CFM | NET COOLING CAPACITY AT 95°F (35°C) (Btuh) | EER† | SEER** |
|------|--------------|--------------|--|------|--------|
| 24 | 2 | 800 | 24,000 | 11.5 | 13.5 |
| 30 | 2.5 | 1000 | 28,800 | 11.5 | 13.5 |
| 36 | 3 | 1200 | 36,000 | 11.5 | 13.5 |
| 42 | 3.5 | 1400 | 41,500 | 11.5 | 13.5 |
| 48 | 4 | 1600 | 46,500 | 11.5 | 13.5 |
| 60 | 5 | 1750 | 55,000 | 11.0 | 13.0 |

AHRI CAPACITY RATINGS – HEATING CAPACITIES AND EFFICIENCIES

| PHJ3 | NET HEATING CAPACITY AT 47°F (8.3°C) (Btuh) | COP @ 17°F (-8.3°C) | NET HEATING CAPACITY AT 17°F (-8.3°C) (Btuh) | COP @ 17°F (-8.3°C) | HSPF** |
|------|---|---------------------|--|---------------------|--------|
| 24 | 23,800 | 3.7 | 13,200 | 2.3 | 7.7 |
| 30 | 28,600 | 3.7 | 15,600 | 2.3 | 7.7 |
| 36 | 34,400 | 3.5 | 18,800 | 2.2 | 7.7 |
| 42 | 41,000 | 3.6 | 23,200 | 2.3 | 7.7 |
| 48 | 46,500 | 3.6 | 27,000 | 2.3 | 7.7 |
| 60 | 55,000 | 3.4 | 31,800 | 2.2 | 7.7 |

LEGEND

dB—Sound Levels (decibels)

db—Dry Bulb

SEER—Seasonal Energy Efficiency Ratio

wb—Wet Bulb

COP—Coefficient of Performance

* Air Conditioning Heating & Refrigeration Institute

† At "A" conditions—80°F (26.7°C) indoor db/67°F (19.4°C) indoor wb & 95°F (35°C) outdoor db.

** Rated in accordance with U.S. Government DOE Department of Energy) test procedures and/or AHRI Standards 210/240-08.

Notes:

1. Ratings are net values, reflecting the effects of circulating fan heat. Ratings are based on:

Cooling Standard: 80°F (26.7°C) db, 67°Fwb (19.4°C) indoor entering-air

temperature and 95°F db (35°C) outdoor entering-air temperature.

2. Before purchasing this appliance, read important energy cost and efficiency information available from your retailer.



Use of the AHRI Certified TM Mark indicates a manufacturer's participation in the program. For verification of certification for individual products, go to www.ahridirectory.org .



A-Weighted Sound Power Level (dBA)

| PHJ3 | STANDARD RATING (dBA) | TYPICAL OCTAVE BAND SPECTRUM (dBA without tone adjustment) | | | | | | |
|------|-----------------------|--|------|------|------|------|------|------|
| | | 125 | 250 | 500 | 1000 | 2000 | 4000 | 8000 |
| 24 | 73 | 61 | 63.5 | 68 | 65.5 | 59 | 52 | 46 |
| 30 | 74 | 65.5 | 63 | 65 | 64.5 | 61 | 56.5 | 53.5 |
| 36 | 75 | 64.5 | 68.5 | 69.5 | 69 | 64.5 | 59 | 51.5 |
| 42 | 77 | 70.5 | 67 | 72 | 70.5 | 65 | 60 | 51.5 |
| 48 | 76 | 68.5 | 70 | 70 | 70 | 65.5 | 60.5 | 53.5 |
| 60 | 79 | 66 | 71.5 | 72.5 | 74 | 70.5 | 65.5 | 57.5 |

| PHYSICAL DATA – PHJ3 | | | | | | |
|--|--------------------------|-----------------------|-----------------------|------------|-----------------------|------------|
| UNIT SIZE | 24 | 30 | 36 | 42 | 48 | 60 |
| NOMINAL CAPACITY (ton) | 2 | 2.5 | 3 | 3.5 | 4 | 5 |
| SHIPPING WEIGHT (lb) | 312 | 314 | 334 | 388 | 407 | 420 |
| (kg) | 142 | 143 | 152 | 177 | 185 | 191 |
| COMPRESSOR TYPE | SCROLL | | | | | |
| REFRIGERANT | R-410A | | | | | |
| REFRIGERANT QUANTITY (lb) | 5.50 | 6.70 | 5.85 | 7.00 | 7.50 | 8.50 |
| QUANTITY (kg) | 2.49 | 3.04 | 2.65 | 3.18 | 3.40 | 3.86 |
| OUTDOOR METERING DEVICE | Piston | | | | | |
| ORIFICE OD (in.) | 0.049 | 0.049 | 0.057 | 0.061 | 0.067 | 0.073 |
| (mm) | 1.245 | 1.245 | 1.448 | 1.549 | 1.702 | 1.854 |
| OUTDOOR COIL ROWS...FINS/in. | 2...20 | 2...20 | 2...20 | 2...20 | 2...20 | 2...20 |
| FACE AREA (sq. ft) | 9.1 | 9.1 | 10.2 | 13.0 | 15.5 | 15.5 |
| OUTDOOR FAN NOMINAL AIRFLOW (cfm) | 2000 | 2000 | 2800 | 3100 | 2900 | 3200 |
| DIAMETER (in.) | 20 | 20 | 20 | 20 | 20 | 20 |
| DIAMETER (mm) | 508 | 508 | 508 | 508 | 508 | 508 |
| MOTOR HP (RPM) | 1/8 (825) | 1/8 (825) | 1/4 (1100) | 1/4 (1100) | 1/4 (1100) | 1/3 (1110) |
| INDOOR METERING DEVICE | Piston | | | | | TXV |
| ORIFICE OD (in.) | 0.059 | 0.059 | 0.067 | 0.073 | 0.080 | N/A |
| (mm) | 1.499 | 1.499 | 1.702 | 1.854 | 2.032 | |
| INDOOR COIL ROWS...FINS/in. | 3...12 | 3...12 | 3...12 | 3...12 | 3...12 | 3...12 |
| FACE AREA (sq. ft) | 4.3 | 4.3 | 4.9 | 4.9 | 4.9 | 6.1 |
| INDOOR BLOWER NOMINAL COOLING AIRFLOW (cfm) | 800 | 1000 | 1200 | 1400 | 1600 | 1750 |
| NOMINAL SIZE D x L (in.) | 10 x 8 | 10 x 8 | 11 x 9 | 11 x 9 | 11 x 10 | 11 x 10 |
| (mm) | 254 x 203 | 254 x 203 | 279 x 229 | 279 x 229 | 279 x 254 | 279 x 254 |
| MOTOR (HP) | 1/3 | 1/3 | 1/2 | 1/2 | 3/4 | 1 |
| HIGH-PRESSURE SWITCH (psig) CUTOUT RESET (AUTO) | 650 +/- 15 420 +/- 25 | | | | | |
| LOW-PRESSURE SWITCH (psig) CUTOUT RESET (AUTO) | 20 +/- 5 45 +/- 10 | | | | | |
| RETURN-AIR FILTERS THROWAWAY (in.) (mm) | 20x20x1 508x508x25 | 20x24x1 508x610x25 | 24x30x1 610x762x25 | | 24x36x1 610x914x25 | |

*Required filter sizes shown are based on the AHRI (Air Conditioning, Heating and Refrigeration Institute) rated airflow at a velocity of 300 ft/min for throwaway type or 450 ft/min for high capacity type. Recommended filters are 1-in. (25.4 mm) thick.

UNIT DIMENSIONS - PHJ324-36

| UNIT | ELECTRICAL CHARACTERISTICS | | UNIT WT. | | UNIT HEIGHT | | CENTER OF GRAVITY IN (MM) | | |
|--------|----------------------------|-----|----------|------|-------------|------|---------------------------|-----|--|
| | LBS. | KG. | A | B | X | Y | Z | | |
| PHJ324 | 207 | 94 | 30-1/8 | 1765 | 14 | 1483 | 14 | 356 | |
| PHJ330 | 264 | 120 | 30-1/8 | 1765 | 14 | 1483 | 14 | 356 | |
| PHJ336 | 285 | 130 | 34-1/8 | 1867 | 14 | 1483 | 16 | 408 | |

REQUIRED CLEARANCES TO COMBUSTIBLE MATL.

TOP OF UNIT..... 0
 BOTTOM OF UNIT..... 0
 SIDE OF UNIT WITH DUCT OPENINGS..... 0
 SIDE OF UNIT OPPOSITE DUCT OPENINGS..... 0

NEC. REQUIRED CLEARANCES.

INCHES (MM)

BETWEEN UNITS, POWER ENTRY SIDE..... 42.0 (1067)
 UNIT AND UNGROUNDED SURFACES, POWER ENTRY SIDE..... 36.0 (914)
 UNIT AND BLOCK OR CONCRETE WALLS AND OTHER GROUNDED SURFACES, POWER ENTRY SIDE..... 42.0 (1067)

REQUIRED CLEARANCE FOR SERVICING

INCHES (MM)

TOP OF UNIT, OPPOSITE DUCT OPENINGS..... 36.0 (914)
 BOTTOM OF UNIT..... 0
 SIDE OF UNIT WITH POWER ENTRY (EXCEPT FOR NEC REQUIREMENTS)..... 30.0 (762)

NOTE: CLEARANCES MUST BE MAINTAINED TO PREVENT RECIRCULATION OF AIR FROM THE UNIT. A REMOVABLE FENCE OR BARRICADE REQUIRES NO CLEARANCE.

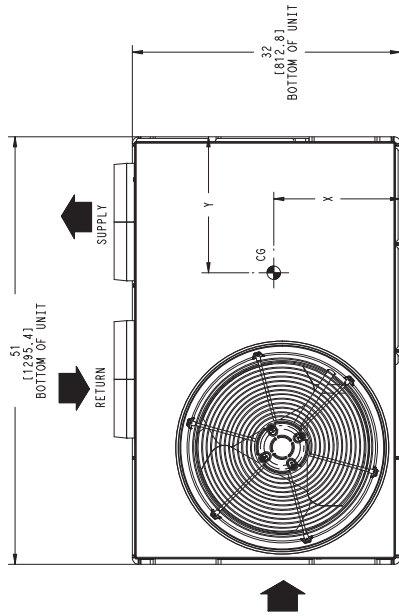

TOP VIEW

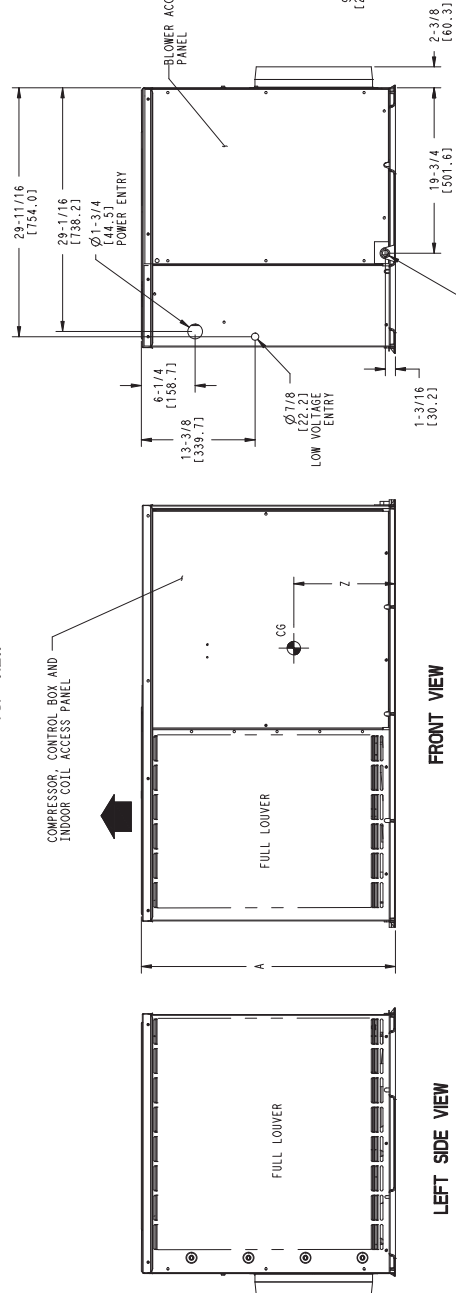

FRONT VIEW

LEFT SIDE VIEW

RIGHT SIDE VIEW

REAR VIEW

DIMENSIONS IN () ARE IN MM

UNIT DIMENSIONS - PHJ342-60

| UNIT | ELECTRICAL CHARACTERISTICS | | UNIT WT. | | | UNIT HEIGHT | | | CENTER OF GRAVITY IN (MM) | | |
|--------|----------------------------|----|----------|-----|---------------|-------------|----------|--------------|---------------------------|--|--|
| | RG. | PH | LB. | KG. | A | X | Y | Z | | | |
| PHJ342 | 208/230-1-60 | | 339 | 154 | 42-1/8 [1070] | 14 [356] | 19 [483] | 19-3/4 [503] | | | |
| PHJ348 | 208/230-1-60 | | 358 | 163 | 42-1/8 [1070] | 14 [356] | 19 [483] | 19-3/4 [503] | | | |
| PHJ360 | 208/230-1-60 | | 371 | 169 | 42-1/8 [1070] | 14 [356] | 19 [483] | 19-3/4 [503] | | | |

REQUIRED CLEARANCES TO COMBUSTIBLE MATL.

TOP OF UNIT..... INCHES (MM)0
 BOTTOM OF UNIT WITH DUCT OPENINGS.....0
 SIDE OF UNIT OPPOSITE DUCT OPENINGS.....0

MEC. REQUIRED CLEARANCES

BETWEEN UNITS, POWER ENTRY SIDE..... INCHES (MM)0
 UNIT AND UNGROUND SURFACES, POWER ENTRY SIDE.....36.0 (914)
 UNIT AND BLOCK OR CONCRETE WALLS AND OTHER GROUND SURFACES, POWER ENTRY SIDE.....42.0 (1067)

REQUIRED CLEARANCE FOR SERVICING

TOP OF UNIT..... INCHES (MM)36.0 (914)
 SIDE OF UNIT OPPOSITE DUCT OPENINGS.....30.0 (762)
 SIDE OF UNIT WITH DUCT OPENINGS.....30.0 (762)
 (EXCEPT FOR NEC REQUIREMENTS)

NOTE: CLEARANCES MUST BE MAINTAINED TO PREVENT RECIRCULATION OF AIR FROM OUTDOOR FAN DISCHARGE. A REMOVABLE FENCE OR BARRICADE REQUIRES NO CLEARANCE.

DIMENSIONS IN [] ARE IN MM

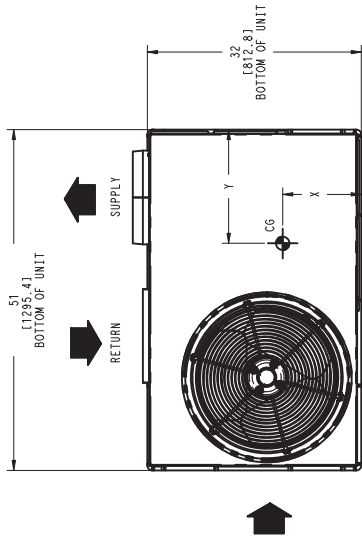

TOP VIEW

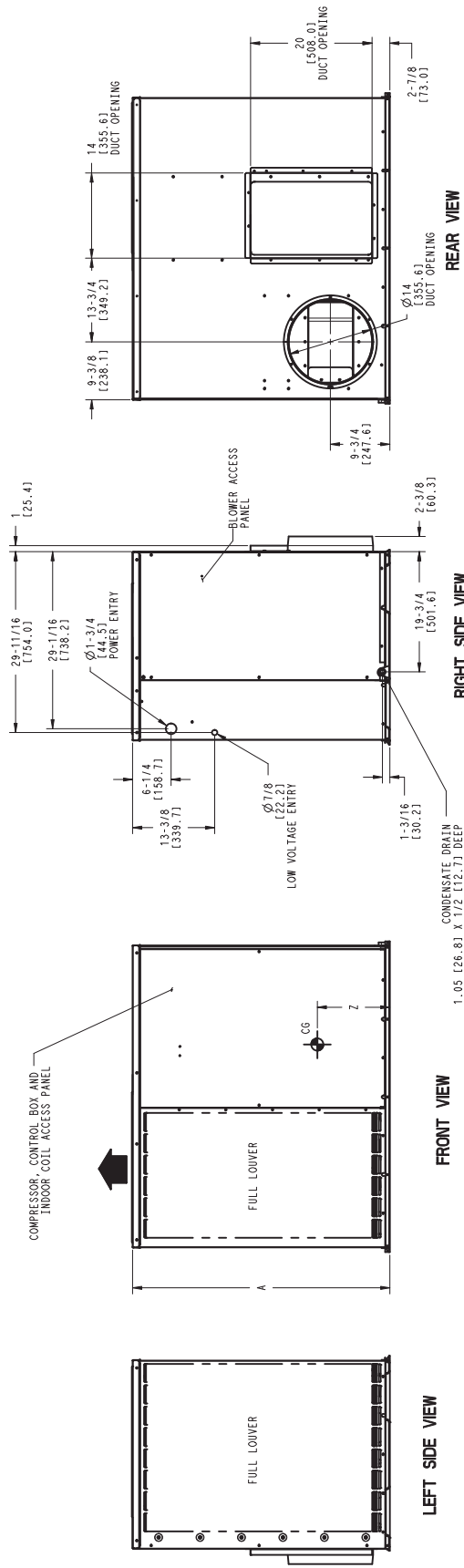

| | | |
|-----|------------|---|
| REV | 50ZH500473 | - |
|-----|------------|---|

SELECTION PROCEDURE

I. DETERMINE COOLING AND HEATING REQUIREMENTS AT DESIGN CONDITIONS

Given:

- Required Cooling Capacity (TC) 28,000 Btuh
- Sensible Heat Capacity (SHC) 20,500 Btuh
- Required Heating Capacity 28,550 Btuh
- Outdoor Entering–Air Temperature 95°F (35°C)
- Outdoor–Air Winter Design Temperature 20°F (–6.7°C)
- Indoor–Air Winter Design Temperature 70°F (21.1°C)
- Indoor Entering–Air Temperature 80°F (26.7°C)
- edb, 67°F ewb (19.4°C)
- Indoor–Air Quantity 1000 CFM
- External Static Pressure 0.20 IN. W.C.
- Electrical Characteristics (V–Ph–Hz) 230–1–60
- edb — entering dry bulb
- ewb — entering wet bulb

II. SELECT UNIT BASED ON REQUIRED COOLING CAPACITY

Enter Cooling Capacities table at condenser entering temperature of 95°F (35°C), indoor air entering at 1000 cfm and 67°F (19.4°C) ewb (entering wet bulb). The PHJ330 unit will provide a total cooling capacity of 28,800 Btuh and a sensible heat capacity of 21,600 Btuh.

For indoor–air temperature other than 80°F edb (entering dry bulb), calculate sensible heat capacity correction, as required, using the formula found in Note 3 following the cooling capacities tables.

NOTE: Unit ratings are net capacities.

III. SELECT ELECTRIC HEAT

Enter the PHJ330 Heating Capacities table at 1000 CFM. At 70°F (21.1°C) return indoor air and 20°F (–6.7°C) air entering outdoor coil, the integrated heating capacity is 16,740 Btuh. (Select integrated heating capacity value since deductions for outdoor–coil frost and defrosting have already been made. No correction is required.)

The required heating capacity is 28,550 Btuh. Therefore, 11,810 Btuh (28,550 – 16,740) additional electric heat is required.

Determine additional electric heat capacity in kW.

$$\frac{11,810 \text{ Btuh}}{3414 \text{ Btuh/kW}} = 3.46 \text{ kW of heat required}$$

Enter the Accessory Electric Heater Usage table on page 4 for 208/240v. single–phase, PHJ330 unit. The 5–kW heater at 240v most closely satisfies the heating required. To calculate kW at 230v, multiply the heater kW by multiplication factor 0.92 found in the Multiplication Factors table on page 5.

$$5 \text{ kW} \times 0.92 = 4.6 \text{ kW}$$

$$4.6 \times 3414 = 15,704 \text{ Btuh}$$

To calculate kW at 208 v, see Multiplication Factors table on page 5.

Total unit heating capacity is 32,444 Btuh (16,740 +15,704).

IV. DETERMINE FAN SPEED AND POWER REQUIREMENTS AT DESIGN CONDITIONS

Before entering the air delivery tables, calculate the total static pressure required. From the given, the Accessory Electric Heat Pressure Drop table, and the Filter Pressure Drop table, find:

| | |
|--------------------------|---------------|
| External static pressure | 0.20 IN. W.C. |
| Filter | 0.09 IN. W.C. |
| Electric heat | 0.04 IN. W.C. |
| Total static pressure | 0.33 IN. W.C. |

Enter the table for Dry Coil Air Delivery — Horizontal Discharge at 1000 CFM and 230v high speed. The blower will deliver 1036 CFM @ 0.40 IN W.C. static pressure. This will adequately handle job requirements.

BALANCE POINT WORKSHEET

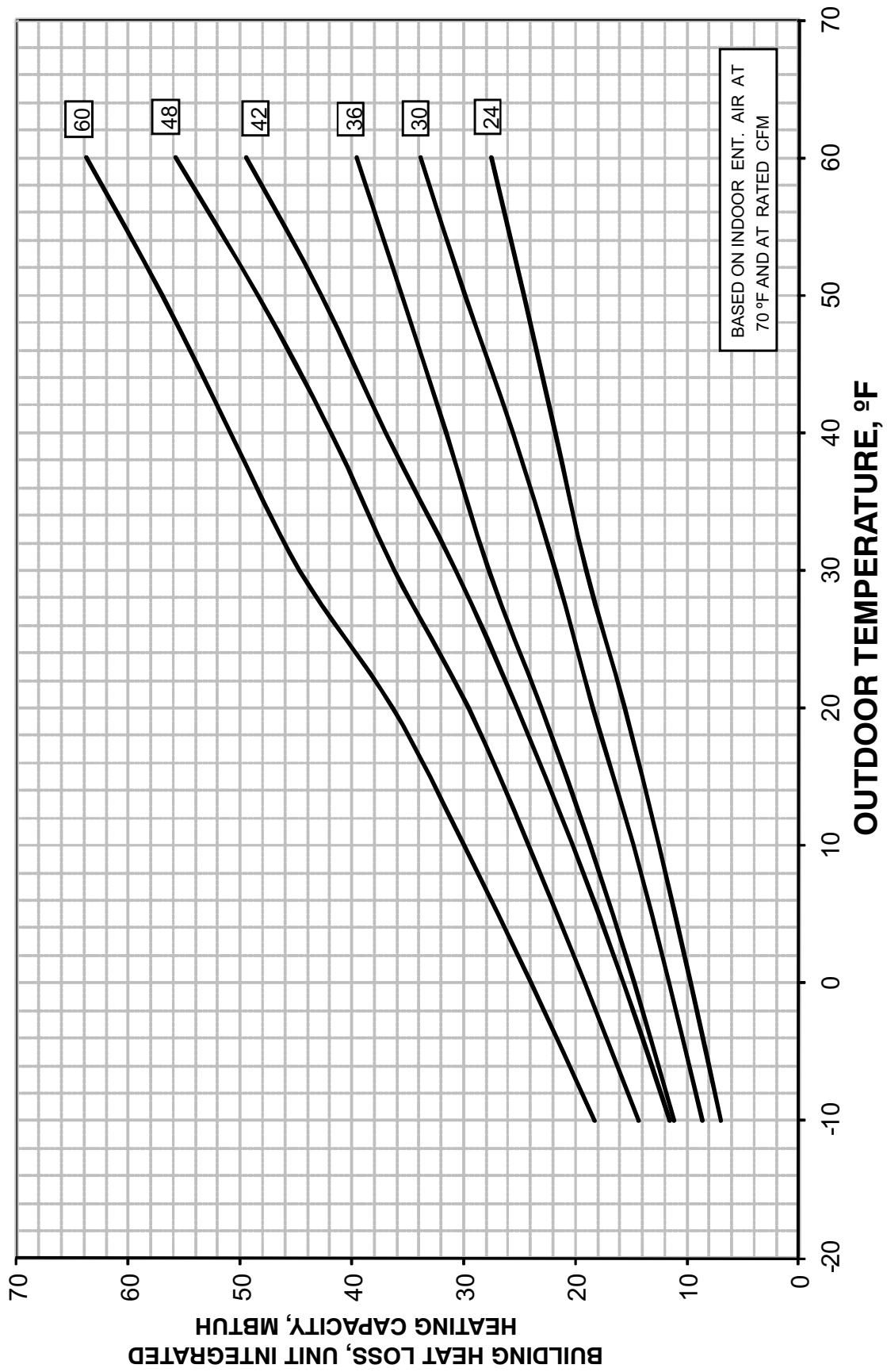

PERFORMANCE DATA

Cooling Capacities

PHJ324

| EVAPORATOR AIR | | CONDENSER ENTERING AIR TEMPERATURES °F (°C) | | | | | | | | | | | | | | | | | |
|----------------|-------------|---|-------|--------------|----------------|-------|--------------|----------------|-------|--------------|----------------|-------|--------------|----------------|-------|--------------|----------------|-------|--------------|
| | | 75 (24) | | | 85 (29) | | | 95 (35) | | | 105 (41) | | | 115 (46) | | | 125 (52) | | |
| | | Capacity MBtuh | | Total Sys KW | Capacity MBtuh | | Total Sys KW | Capacity MBtuh | | Total Sys KW | Capacity MBtuh | | Total Sys KW | Capacity MBtuh | | Total Sys KW | Capacity MBtuh | | Total Sys KW |
| CFM / BF | EWB °F (°C) | Total | Sens | Total | Sens | Total | Sens | Total | Sens | Total | Sens | Total | Sens | Total | Sens | Total | Sens | Total | Sens |
| 700 / 0.08 | 57 (14) | 22.96 | 22.96 | 1.61 | 22.41 | 22.41 | 1.82 | 21.85 | 21.85 | 2.05 | 20.67 | 20.67 | 2.30 | 19.14 | 19.14 | 2.58 | 17.50 | 17.50 | 2.90 |
| | 62 (17) | 23.69 | 21.83 | 1.61 | 21.68 | 21.68 | 1.82 | 21.56 | 21.56 | 2.06 | 20.80 | 21.27 | 2.30 | 19.18 | 19.18 | 2.58 | 17.53 | 17.53 | 2.90 |
| | 63* (17) | 24.01 | 17.90 | 1.62 | 23.29 | 17.85 | 1.83 | 22.50 | 17.48 | 2.06 | 21.20 | 17.16 | 2.30 | 19.18 | 16.18 | 2.58 | 16.93 | 15.19 | 2.89 |
| | 67 (19) | 25.13 | 17.88 | 1.62 | 24.56 | 17.79 | 1.84 | 23.72 | 17.60 | 2.07 | 22.89 | 17.60 | 2.33 | 21.31 | 17.22 | 2.61 | 19.11 | 16.34 | 2.91 |
| | 72 (22) | 26.32 | 14.26 | 1.63 | 25.98 | 14.21 | 1.85 | 25.12 | 13.86 | 2.09 | 24.29 | 13.62 | 2.35 | 23.47 | 13.52 | 2.64 | 21.77 | 13.02 | 2.96 |
| 800 / 0.10 | 57 (14) | 23.63 | 23.63 | 1.63 | 23.07 | 23.07 | 1.84 | 22.46 | 22.46 | 2.07 | 21.68 | 21.68 | 2.33 | 20.19 | 20.19 | 2.61 | 18.49 | 18.49 | 2.92 |
| | 62 (17) | 24.06 | 22.94 | 1.63 | 23.37 | 22.84 | 1.84 | 22.60 | 22.82 | 2.07 | 21.71 | 21.71 | 2.33 | 20.22 | 20.22 | 2.61 | 18.53 | 18.53 | 2.92 |
| | 63 (17) | 24.35 | 18.61 | 1.63 | 23.64 | 18.46 | 1.84 | 22.84 | 18.37 | 2.08 | 21.72 | 18.34 | 2.33 | 19.71 | 17.50 | 2.60 | 17.41 | 16.44 | 2.91 |
| | 67 (19) | 25.41 | 18.51 | 1.64 | 24.88 | 18.54 | 1.86 | 24.00 | 18.38 | 2.09 | 23.13 | 18.35 | 2.35 | 21.77 | 18.42 | 2.63 | 19.57 | 17.63 | 2.93 |
| | 72 (22) | 26.54 | 14.57 | 1.65 | 26.23 | 14.57 | 1.87 | 25.38 | 14.26 | 2.10 | 24.52 | 14.04 | 2.36 | 23.60 | 13.86 | 2.66 | 22.15 | 13.70 | 2.98 |
| 900 / 0.11 | 57 (14) | 24.11 | 24.11 | 1.64 | 23.60 | 23.60 | 1.86 | 22.95 | 22.95 | 2.09 | 22.34 | 22.34 | 2.35 | 21.00 | 21.00 | 2.63 | 19.26 | 19.26 | 2.94 |
| | 62 (17) | 24.35 | 23.89 | 1.65 | 23.70 | 23.84 | 1.86 | 22.36 | 22.36 | 2.09 | 22.37 | 22.37 | 2.35 | 21.03 | 21.03 | 2.63 | 19.29 | 19.29 | 2.95 |
| | 63 (17) | 24.59 | 19.25 | 1.65 | 23.92 | 19.21 | 1.86 | 23.08 | 19.15 | 2.09 | 22.09 | 19.38 | 2.34 | 20.12 | 18.68 | 2.62 | 17.82 | 17.82 | 2.93 |
| | 67 (19) | 25.62 | 19.06 | 1.66 | 25.12 | 19.22 | 1.87 | 24.22 | 19.09 | 2.10 | 23.35 | 19.14 | 2.36 | 22.12 | 19.49 | 2.65 | 19.95 | 18.82 | 2.96 |
| | 72 (22) | 26.70 | 14.83 | 1.66 | 26.39 | 14.85 | 1.89 | 25.57 | 14.60 | 2.12 | 24.68 | 14.39 | 2.38 | 23.72 | 14.27 | 2.67 | 22.41 | 14.30 | 3.00 |

Heating Capacities

PHJ324

| INDOOR AIR | | OUTDOOR COIL ENTERING AIR TEMPERATURES °F (°C) | | | | | | | | | | | | | | | | | | | | | | | |
|-----------------------|-----|--|-------|--------------|----------------|-------|--------------|----------------|-------|--------------|----------------|-------|--------------|----------------|-------|--------------|----------------|-------|--------------|----------------|-------|--------------|---------|-------|------|
| | | -10 (-23) | | | 0 (-18) | | | 10 (-12) | | | 20 (-7) | | | 30 (-1) | | | 40 (4) | | | 50 (10) | | | 60 (16) | | |
| | | Capacity MBtuh | | Total Sys KW | Capacity MBtuh | | Total Sys KW | Capacity MBtuh | | Total Sys KW | Capacity MBtuh | | Total Sys KW | Capacity MBtuh | | Total Sys KW | Capacity MBtuh | | Total Sys KW | Capacity MBtuh | | Total Sys KW | | | |
| Return Air db °F (°C) | CFM | Total | Integ | Total | Integ | Total | Integ | Total | Integ | Total | Integ | Total | Integ | Total | Integ | Total | Integ | Total | Integ | Total | Integ | | | | |
| 65 (18) | 700 | 7.28 | 6.69 | 1.47 | 9.93 | 9.14 | 1.58 | 12.73 | 11.69 | 1.65 | 15.77 | 14.31 | 1.71 | 19.17 | 16.80 | 1.76 | 22.00 | 22.00 | 1.80 | 24.93 | 24.93 | 1.86 | 28.00 | 28.00 | 1.93 |
| | 800 | 7.38 | 6.79 | 1.47 | 10.06 | 9.26 | 1.57 | 12.89 | 11.83 | 1.64 | 16.00 | 14.51 | 1.69 | 19.24 | 16.86 | 1.73 | 22.03 | 22.03 | 1.76 | 24.89 | 24.89 | 1.80 | 27.83 | 27.83 | 1.86 |
| | 900 | 7.47 | 6.88 | 1.48 | 10.19 | 9.37 | 1.57 | 13.05 | 11.98 | 1.63 | 16.17 | 14.67 | 1.67 | 19.28 | 16.90 | 1.70 | 22.02 | 22.02 | 1.73 | 24.80 | 24.80 | 1.76 | 27.58 | 27.58 | 1.80 |
| 70 (21) | 700 | 6.86 | 6.31 | 1.54 | 9.53 | 8.77 | 1.65 | 12.35 | 11.33 | 1.73 | 15.38 | 13.95 | 1.79 | 18.97 | 16.62 | 1.85 | 21.76 | 21.76 | 1.90 | 24.66 | 24.66 | 1.96 | 27.67 | 27.67 | 2.03 |
| | 800 | 6.97 | 6.42 | 1.54 | 9.68 | 8.91 | 1.65 | 12.52 | 11.49 | 1.72 | 15.59 | 14.14 | 1.77 | 19.05 | 16.69 | 1.82 | 21.81 | 21.81 | 1.85 | 24.65 | 24.65 | 1.90 | 27.55 | 27.55 | 1.96 |
| | 900 | 7.08 | 6.51 | 1.55 | 9.80 | 9.02 | 1.65 | 12.67 | 11.63 | 1.71 | 15.77 | 14.30 | 1.76 | 19.10 | 16.73 | 1.79 | 21.82 | 21.82 | 1.82 | 24.59 | 24.59 | 1.86 | 27.34 | 27.34 | 1.90 |
| 75 (24) | 700 | 6.38 | 5.87 | 1.61 | 9.11 | 8.38 | 1.73 | 11.94 | 10.96 | 1.81 | 14.96 | 13.57 | 1.88 | 18.68 | 16.37 | 1.96 | 21.53 | 21.53 | 2.00 | 24.41 | 24.41 | 2.06 | 27.35 | 27.35 | 2.14 |
| | 800 | 6.50 | 5.98 | 1.61 | 9.25 | 8.51 | 1.73 | 12.11 | 11.12 | 1.80 | 15.18 | 13.76 | 1.86 | 18.85 | 16.51 | 1.92 | 21.58 | 21.58 | 1.95 | 24.41 | 24.41 | 2.00 | 27.27 | 27.27 | 2.06 |
| | 900 | 6.62 | 6.09 | 1.62 | 9.38 | 8.63 | 1.72 | 12.26 | 11.25 | 1.79 | 15.35 | 13.92 | 1.84 | 18.92 | 16.57 | 1.89 | 21.60 | 21.60 | 1.92 | 24.34 | 24.34 | 1.96 | 27.07 | 27.07 | 2.01 |

See Legend and Notes on page 15.

PERFORMANCE DATA (CONT.)

Cooling Capacities

PHJ330

| EVAPORATOR AIR | | CONDENSER ENTERING AIR TEMPERATURES °F (°C) | | | | | | | | | | | | | | | | | | |
|----------------|-------------|---|-------------|----------------|---------|--------------|----------------|---------|--------------|----------------|----------|--------------|----------------|----------|--------------|----------------|----------|--------------|-------|------|
| | | 75 (24) | | | 85 (29) | | | 95 (35) | | | 105 (41) | | | 115 (46) | | | 125 (52) | | | |
| | | CFM / BF | EWB °F (°C) | Capacity MBtuh | | Total Sys kW | Capacity MBtuh | | Total Sys kW | Capacity MBtuh | | Total Sys kW | Capacity MBtuh | | Total Sys kW | Capacity MBtuh | | Total Sys kW | | |
| Total | Sens | | | Total | Sens | | Total | Sens | | Total | Sens | | Total | Sens | | | | | | |
| | | 57 (14) | 27.82 | 27.82 | 1.97 | 27.30 | 27.30 | 2.20 | 26.53 | 26.53 | 2.45 | 25.50 | 25.50 | 2.75 | 24.19 | 24.19 | 3.08 | 22.57 | 22.57 | 3.47 |
| | | 62 (17) | 28.38 | 25.57 | 1.98 | 27.75 | 25.67 | 2.20 | 26.84 | 25.54 | 2.46 | 25.63 | 25.09 | 2.75 | 24.24 | 24.24 | 3.08 | 22.60 | 22.60 | 3.47 |
| | 875 / 0.08 | 63* (17) | 28.69 | 20.76 | 1.98 | 28.06 | 20.76 | 2.21 | 27.16 | 20.58 | 2.46 | 25.94 | 20.16 | 2.75 | 24.37 | 19.46 | 3.08 | 22.28 | 18.53 | 3.45 |
| | | 67 (19) | 29.82 | 20.56 | 1.99 | 29.31 | 20.71 | 2.22 | 28.51 | 20.67 | 2.48 | 27.39 | 20.44 | 2.77 | 26.01 | 20.06 | 3.10 | 24.38 | 19.55 | 3.48 |
| | | 72 (22) | 31.10 | 16.25 | 2.00 | 30.75 | 16.22 | 2.24 | 30.03 | 16.06 | 2.50 | 29.06 | 15.79 | 2.80 | 27.80 | 15.42 | 3.13 | 26.20 | 14.93 | 3.51 |
| | | 57 (14) | 28.43 | 28.43 | 2.00 | 27.96 | 27.96 | 2.23 | 27.26 | 27.26 | 2.49 | 26.29 | 26.29 | 2.78 | 25.07 | 25.07 | 3.11 | 23.66 | 23.66 | 3.49 |
| | 1000 / 0.09 | 62 (17) | 28.74 | 26.78 | 2.00 | 28.15 | 27.00 | 2.23 | 27.28 | 27.28 | 2.49 | 26.31 | 26.31 | 2.78 | 25.10 | 25.10 | 3.11 | 23.69 | 23.69 | 3.49 |
| | | 63 (17) | 28.99 | 21.57 | 2.00 | 28.39 | 21.71 | 2.23 | 27.51 | 21.66 | 2.49 | 26.30 | 21.37 | 2.78 | 24.79 | 20.84 | 3.11 | 22.73 | 19.92 | 3.49 |
| | | 67 (19) | 30.09 | 21.27 | 2.01 | 29.60 | 21.54 | 2.24 | 28.80 | 21.60 | 2.50 | 27.69 | 21.48 | 2.80 | 26.31 | 21.22 | 3.13 | 24.66 | 20.78 | 3.51 |
| | | 72 (22) | 31.31 | 16.55 | 2.02 | 30.99 | 16.61 | 2.26 | 30.28 | 16.51 | 2.52 | 29.32 | 16.30 | 2.82 | 28.04 | 15.98 | 3.16 | 26.45 | 15.54 | 3.54 |
| | | 57 (14) | 28.85 | 28.85 | 2.02 | 28.44 | 28.44 | 2.25 | 27.77 | 27.77 | 2.51 | 26.82 | 26.82 | 2.81 | 25.64 | 25.64 | 3.14 | 24.25 | 24.25 | 3.52 |
| | 1125 / 0.10 | 62 (17) | 29.02 | 27.77 | 2.02 | 28.45 | 28.45 | 2.25 | 27.79 | 27.79 | 2.51 | 26.84 | 26.84 | 2.81 | 25.66 | 25.66 | 3.14 | 24.27 | 24.27 | 3.52 |
| | | 63 (17) | 29.21 | 22.27 | 2.03 | 28.63 | 22.55 | 2.26 | 27.76 | 22.62 | 2.51 | 26.56 | 22.44 | 2.80 | 25.09 | 22.04 | 3.13 | 23.18 | 21.25 | 3.51 |
| | | 67 (19) | 30.29 | 21.86 | 2.04 | 29.82 | 22.26 | 2.27 | 29.01 | 22.42 | 2.53 | 27.91 | 22.42 | 2.82 | 26.53 | 22.26 | 3.16 | 24.87 | 21.88 | 3.53 |
| | | 72 (22) | 31.49 | 16.86 | 2.05 | 31.16 | 16.94 | 2.28 | 30.46 | 16.89 | 2.55 | 29.51 | 16.74 | 2.84 | 28.22 | 16.46 | 3.18 | 26.63 | 16.08 | 3.56 |

Heating Capacities

PHJ330

| INDOOR AIR | | OUTDOOR COIL ENTERING AIR TEMPERATURES °F (°C) | | | | | | | | | | | | | | | | | | | | | | | | |
|------------|---------|--|------|----------------|---------|--------------|----------------|----------|--------------|----------------|---------|--------------|----------------|---------|--------------|----------------|--------|--------------|----------------|---------|--------------|----------------|---------|--------------|-------|------|
| | | -10 (-23) | | | 0 (-18) | | | 10 (-12) | | | 20 (-7) | | | 30 (-1) | | | 40 (4) | | | 50 (10) | | | 60 (16) | | | |
| | | Return Air db °F (°C) | CFM | Capacity MBtuh | | Total Sys kW | Capacity MBtuh | | Total Sys kW | Capacity MBtuh | | Total Sys kW | Capacity MBtuh | | Total Sys kW | Capacity MBtuh | | Total Sys kW | Capacity MBtuh | | Total Sys kW | Capacity MBtuh | | Total Sys kW | | |
| Total | Integ | | | Total | Integ | | Total | Integ | | Total | Integ | | Total | Integ | | Total | Integ | | Total | Integ | | Total | Integ | | | |
| | | 875 | 8.92 | 8.21 | 1.74 | 11.84 | 10.90 | 1.81 | 15.00 | 13.77 | 1.88 | 18.52 | 16.80 | 1.96 | 21.87 | 19.17 | 2.03 | 25.66 | 25.66 | 2.12 | 29.97 | 29.97 | 2.24 | 34.48 | 34.48 | 2.34 |
| | 65 (18) | 1000 | 9.05 | 8.32 | 1.74 | 11.99 | 11.03 | 1.81 | 15.17 | 13.93 | 1.87 | 18.67 | 16.93 | 1.94 | 22.07 | 19.34 | 2.01 | 25.91 | 25.91 | 2.09 | 30.27 | 30.27 | 2.18 | 34.10 | 34.10 | 2.27 |
| | | 1125 | 9.16 | 8.43 | 1.75 | 12.12 | 11.15 | 1.81 | 15.34 | 14.08 | 1.87 | 18.80 | 17.05 | 1.93 | 22.24 | 19.48 | 1.99 | 26.12 | 26.12 | 2.07 | 30.15 | 30.15 | 2.14 | 33.52 | 33.52 | 2.21 |
| | | 875 | 8.51 | 7.83 | 1.82 | 11.47 | 10.55 | 1.90 | 14.63 | 13.42 | 1.97 | 18.30 | 16.60 | 2.06 | 21.60 | 18.93 | 2.14 | 25.33 | 25.33 | 2.23 | 29.56 | 29.56 | 2.30 | 34.13 | 34.13 | 2.46 |
| | 70 (21) | 1000 | 8.65 | 7.96 | 1.83 | 11.63 | 10.70 | 1.89 | 14.81 | 13.59 | 1.96 | 18.45 | 16.74 | 2.04 | 21.80 | 19.10 | 2.11 | 25.59 | 25.59 | 2.19 | 29.89 | 29.89 | 2.30 | 33.85 | 33.85 | 2.38 |
| | | 1125 | 8.77 | 8.07 | 1.84 | 11.77 | 10.83 | 1.90 | 14.97 | 13.74 | 1.96 | 18.58 | 16.85 | 2.03 | 21.97 | 19.25 | 2.09 | 25.80 | 25.80 | 2.17 | 29.95 | 29.95 | 2.25 | 33.38 | 33.38 | 2.33 |
| | | 875 | 8.05 | 7.41 | 1.90 | 11.06 | 10.17 | 1.99 | 14.23 | 13.06 | 2.07 | 18.03 | 16.35 | 2.17 | 21.33 | 18.69 | 2.25 | 25.00 | 25.00 | 2.34 | 29.16 | 29.16 | 2.46 | 33.79 | 33.79 | 2.58 |
| | 75 (24) | 1000 | 8.19 | 7.54 | 1.91 | 11.22 | 10.32 | 1.99 | 14.41 | 13.23 | 2.06 | 18.20 | 16.51 | 2.15 | 21.52 | 18.86 | 2.22 | 25.25 | 25.25 | 2.30 | 29.48 | 29.48 | 2.41 | 33.58 | 33.58 | 2.50 |
| | | 1125 | 8.31 | 7.65 | 1.92 | 11.36 | 10.45 | 1.99 | 14.57 | 13.38 | 2.05 | 18.35 | 16.64 | 2.14 | 21.69 | 19.00 | 2.20 | 25.47 | 25.47 | 2.28 | 29.68 | 29.68 | 2.36 | 33.18 | 33.18 | 2.44 |

See Legend and Notes on page 15.

PERFORMANCE DATA (CONT.)

Cooling Capacities

PHJ336

| EVAPORATOR AIR | | CONDENSER ENTERING AIR TEMPERATURES °F (°C) | | | | | | | | | | | | | | | | | |
|----------------|---------|---|----------------|------|--------------|----------------|--------------|---------|----------------|--------------|----------|----------------|--------------|----------|----------------|--------------|----------|----------------|--------------|
| | | 75 (24) | | | 85 (29) | | | 95 (35) | | | 105 (41) | | | 115 (46) | | | 125 (52) | | |
| | | Return Air db °F (°C) | Capacity MBtuh | | Total Sys kW | Capacity MBtuh | Total Sys kW | | Capacity MBtuh | Total Sys kW | | Capacity MBtuh | Total Sys kW | | Capacity MBtuh | Total Sys kW | | Capacity MBtuh | Total Sys kW |
| Total | Sens | | Total | Sens | | | Total | Sens | | Total | Sens | | Total | Sens | | Total | Sens | | Total |
| 1050 / 0.07 | 57 (14) | 34.80 | 34.80 | 2.48 | 33.68 | 33.68 | 2.76 | 32.36 | 32.36 | 3.07 | 30.96 | 30.96 | 3.42 | 29.36 | 29.36 | 3.81 | 27.11 | 27.11 | 4.25 |
| | 62 (17) | 35.83 | 32.61 | 2.49 | 34.48 | 32.11 | 2.77 | 32.91 | 31.40 | 3.07 | 31.22 | 30.68 | 3.42 | 29.40 | 29.40 | 3.81 | 27.15 | 27.15 | 4.25 |
| | 63 (17) | 36.36 | 26.67 | 2.50 | 34.99 | 26.14 | 2.77 | 33.37 | 25.44 | 3.08 | 31.59 | 24.73 | 3.42 | 29.44 | 24.21 | 3.81 | 26.40 | 22.91 | 4.24 |
| 1200 / 0.08 | 67 (19) | 38.38 | 26.96 | 2.51 | 37.11 | 26.57 | 2.79 | 35.50 | 25.95 | 3.10 | 33.63 | 25.17 | 3.45 | 31.66 | 24.52 | 3.84 | 29.23 | 24.13 | 4.28 |
| | 72 (22) | 40.73 | 21.67 | 2.53 | 39.62 | 21.27 | 2.81 | 38.08 | 20.69 | 3.12 | 36.22 | 19.95 | 3.48 | 34.03 | 19.09 | 3.87 | 31.85 | 18.32 | 4.33 |
| | 57 (14) | 35.86 | 35.86 | 2.52 | 34.74 | 34.74 | 2.80 | 33.39 | 33.39 | 3.11 | 31.88 | 31.88 | 3.46 | 30.41 | 30.41 | 3.85 | 28.30 | 28.30 | 4.30 |
| 1350 / 0.10 | 62 (17) | 36.46 | 34.39 | 2.52 | 35.13 | 33.99 | 2.80 | 33.57 | 33.21 | 3.11 | 31.90 | 31.90 | 3.46 | 30.44 | 30.44 | 3.85 | 28.33 | 28.33 | 4.30 |
| | 63 (17) | 36.90 | 27.87 | 2.53 | 35.55 | 27.41 | 2.80 | 33.90 | 26.75 | 3.11 | 32.04 | 26.02 | 3.46 | 30.02 | 25.74 | 3.85 | 27.04 | 24.67 | 4.28 |
| | 67 (19) | 38.89 | 28.05 | 2.54 | 37.62 | 27.77 | 2.82 | 36.00 | 27.20 | 3.13 | 34.09 | 26.44 | 3.48 | 32.05 | 25.78 | 3.88 | 29.71 | 25.67 | 4.32 |
| 1350 / 0.10 | 72 (22) | 41.16 | 22.23 | 2.56 | 40.07 | 21.90 | 2.84 | 38.52 | 21.34 | 3.16 | 36.64 | 20.63 | 3.51 | 34.40 | 19.76 | 3.91 | 32.17 | 18.97 | 4.36 |
| | 57 (14) | 36.96 | 36.64 | 2.55 | 35.54 | 35.54 | 2.83 | 34.17 | 34.17 | 3.14 | 32.57 | 32.57 | 3.49 | 30.97 | 30.97 | 3.89 | 29.13 | 29.13 | 4.34 |
| | 62 (17) | 36.96 | 35.90 | 2.55 | 35.68 | 35.46 | 2.83 | 34.18 | 34.18 | 3.14 | 32.60 | 32.60 | 3.49 | 31.00 | 31.00 | 3.89 | 29.16 | 29.16 | 4.34 |
| 1350 / 0.10 | 63 (17) | 37.33 | 28.93 | 2.56 | 35.96 | 28.55 | 2.83 | 34.29 | 27.93 | 3.14 | 32.38 | 27.19 | 3.49 | 30.42 | 27.02 | 3.88 | 27.54 | 26.23 | 4.31 |
| | 67 (19) | 39.26 | 29.02 | 2.57 | 38.01 | 28.83 | 2.85 | 36.36 | 28.31 | 3.16 | 34.43 | 27.58 | 3.51 | 32.34 | 26.90 | 3.91 | 30.07 | 26.98 | 4.36 |
| | 72 (22) | 41.47 | 22.69 | 2.59 | 40.40 | 22.43 | 2.87 | 38.85 | 21.91 | 3.19 | 36.95 | 21.25 | 3.54 | 34.68 | 20.35 | 3.94 | 32.39 | 19.54 | 4.39 |

Heating Capacities

PHJ336

| INDOOR AIR | | OUTDOOR COIL ENTERING AIR TEMPERATURES °F (°C) | | | | | | | | | | | | | | | | | | | | | | | |
|------------|-------|--|----------------|------|--------------|----------------|--------------|----------|----------------|--------------|---------|----------------|--------------|---------|----------------|--------------|--------|----------------|--------------|---------|----------------|--------------|---------|----------------|--------------|
| | | -10 (-23) | | | 0 (-18) | | | 10 (-12) | | | 20 (-7) | | | 30 (-1) | | | 40 (4) | | | 50 (10) | | | 60 (16) | | |
| | | Return Air db °F (°C) | Capacity MBtuh | | Total Sys kW | Capacity MBtuh | Total Sys kW | | Capacity MBtuh | Total Sys kW | | Capacity MBtuh | Total Sys kW | | Capacity MBtuh | Total Sys kW | | Capacity MBtuh | Total Sys kW | | Capacity MBtuh | Total Sys kW | | Capacity MBtuh | Total Sys kW |
| Total | Integ | | Total | Sens | | | Total | Sens | | Total | Sens | | Total | Sens | | Total | Sens | | Total | Sens | | Total | Sens | | Total |
| 65 (18) | 1050 | 11.54 | 10.62 | 2.30 | 15.05 | 13.85 | 2.39 | 18.95 | 17.39 | 2.49 | 23.38 | 21.20 | 2.60 | 27.98 | 24.52 | 2.70 | 31.92 | 31.92 | 2.79 | 36.05 | 36.05 | 2.88 | 40.34 | 40.34 | 2.99 |
| | 1200 | 11.73 | 10.79 | 2.31 | 15.27 | 14.05 | 2.39 | 19.21 | 17.63 | 2.48 | 23.78 | 21.56 | 2.58 | 28.06 | 24.59 | 2.66 | 31.92 | 31.92 | 2.74 | 35.94 | 35.94 | 2.82 | 40.00 | 40.00 | 2.90 |
| | 1350 | 11.90 | 10.95 | 2.32 | 15.46 | 14.23 | 2.40 | 19.42 | 17.83 | 2.48 | 24.29 | 22.03 | 2.59 | 28.07 | 24.59 | 2.64 | 31.86 | 31.86 | 2.71 | 35.73 | 35.73 | 2.78 | 39.47 | 39.47 | 2.84 |
| 70 (21) | 1050 | 10.95 | 10.08 | 2.41 | 14.50 | 13.34 | 2.51 | 18.42 | 16.90 | 2.61 | 22.76 | 20.64 | 2.71 | 27.71 | 24.28 | 2.83 | 31.59 | 31.59 | 2.92 | 35.66 | 35.66 | 3.02 | 39.91 | 39.91 | 3.13 |
| | 1200 | 11.15 | 10.25 | 2.42 | 14.72 | 13.55 | 2.51 | 18.67 | 17.14 | 2.60 | 23.07 | 20.92 | 2.69 | 27.78 | 24.34 | 2.79 | 31.61 | 31.61 | 2.87 | 35.59 | 35.59 | 2.96 | 39.62 | 39.62 | 3.04 |
| | 1350 | 11.31 | 10.41 | 2.44 | 14.91 | 13.72 | 2.52 | 18.89 | 17.34 | 2.60 | 23.35 | 21.17 | 2.69 | 27.83 | 24.38 | 2.77 | 31.57 | 31.57 | 2.84 | 35.43 | 35.43 | 2.91 | 39.19 | 39.19 | 2.98 |
| 75 (24) | 1050 | 10.32 | 9.49 | 2.54 | 13.90 | 12.79 | 2.63 | 17.85 | 16.38 | 2.73 | 22.18 | 20.12 | 2.84 | 27.45 | 24.05 | 2.98 | 31.26 | 31.26 | 3.07 | 35.27 | 35.27 | 3.17 | 39.45 | 39.45 | 3.28 |
| | 1200 | 10.51 | 9.67 | 2.55 | 14.12 | 13.00 | 2.63 | 18.11 | 16.62 | 2.73 | 22.49 | 20.40 | 2.82 | 27.54 | 24.13 | 2.94 | 31.29 | 31.29 | 3.01 | 35.23 | 35.23 | 3.10 | 39.24 | 39.24 | 3.19 |
| | 1350 | 10.67 | 9.82 | 2.56 | 14.31 | 13.17 | 2.64 | 18.33 | 16.82 | 2.72 | 22.75 | 20.63 | 2.81 | 27.60 | 24.18 | 2.91 | 31.28 | 31.28 | 2.98 | 35.11 | 35.11 | 3.06 | 38.87 | 38.87 | 3.13 |

See Legend and Notes on page 15.

PERFORMANCE DATA (CONT.)
Cooling Capacities
PHJ342

| EVAPORATOR AIR | | CONDENSER ENTERING AIR TEMPERATURES °F (°C) | | | | | | | | | | | | | | | | | |
|----------------|----------|---|-------------|----------------|---------|--------------|----------------|---------|--------------|----------------|----------|--------------|----------------|----------|--------------|----------------|----------|--------------|------|
| | | 75 (24) | | | 85 (29) | | | 95 (35) | | | 105 (41) | | | 115 (46) | | | 125 (52) | | |
| | | CFM / BF | EWB °F (°C) | Capacity MBtuh | | Total Sys kW | Capacity MBtuh | | Total Sys kW | Capacity MBtuh | | Total Sys kW | Capacity MBtuh | | Total Sys kW | Capacity MBtuh | | Total Sys kW | |
| Total | Sens | | | Total | Sens | | Total | Sens | | Total | Sens | | Total | Sens | | | | | |
| 1225 / 0.11 | 57 (14) | 39.44 | 39.44 | 2.86 | 37.89 | 37.89 | 3.16 | 35.26 | 35.26 | 3.49 | 32.83 | 32.83 | 3.86 | 30.29 | 30.29 | 4.29 | 27.53 | 27.53 | 4.77 |
| | 62 (17) | 40.83 | 36.35 | 2.87 | 38.87 | 35.37 | 3.17 | 35.71 | 33.63 | 3.49 | 32.88 | 32.88 | 3.86 | 30.33 | 30.33 | 4.29 | 27.57 | 27.57 | 4.77 |
| | 63* (17) | 41.77 | 29.61 | 2.87 | 39.75 | 28.75 | 3.18 | 36.73 | 27.48 | 3.50 | 33.21 | 26.03 | 3.87 | 29.73 | 24.59 | 4.28 | 25.94 | 22.96 | 4.74 |
| | 67 (19) | 45.20 | 30.87 | 2.90 | 43.07 | 30.03 | 3.21 | 40.81 | 29.14 | 3.56 | 37.31 | 27.80 | 3.92 | 33.36 | 26.29 | 4.33 | 29.48 | 24.79 | 4.80 |
| | 72 (22) | 50.06 | 25.07 | 2.95 | 47.76 | 24.23 | 3.26 | 45.31 | 23.37 | 3.61 | 42.72 | 22.45 | 4.01 | 39.72 | 21.41 | 4.44 | 34.69 | 19.71 | 4.89 |
| 1400 / 0.12 | 57 (14) | 40.99 | 40.99 | 2.91 | 39.36 | 39.36 | 3.22 | 37.54 | 37.54 | 3.56 | 34.31 | 34.31 | 3.92 | 31.63 | 31.63 | 4.35 | 28.76 | 28.76 | 4.83 |
| | 62 (17) | 41.70 | 38.58 | 2.91 | 39.63 | 39.63 | 3.22 | 37.60 | 37.60 | 3.56 | 34.36 | 34.36 | 3.92 | 31.67 | 31.67 | 4.35 | 28.79 | 28.79 | 4.83 |
| | 63 (17) | 42.59 | 31.37 | 2.92 | 40.50 | 30.50 | 3.23 | 38.19 | 29.53 | 3.57 | 33.90 | 27.77 | 3.92 | 30.31 | 26.24 | 4.33 | 26.48 | 24.45 | 4.79 |
| | 67 (19) | 46.07 | 32.76 | 2.95 | 43.87 | 31.91 | 3.26 | 41.50 | 31.00 | 3.61 | 38.85 | 29.98 | 3.99 | 34.05 | 28.14 | 4.38 | 30.05 | 26.52 | 4.85 |
| | 72 (22) | 51.04 | 26.26 | 3.00 | 48.65 | 25.41 | 3.32 | 46.10 | 24.53 | 3.67 | 43.42 | 23.60 | 4.06 | 40.39 | 22.57 | 4.50 | 35.44 | 20.92 | 4.95 |
| 1575 / 0.14 | 57 (14) | 42.35 | 42.35 | 2.96 | 40.65 | 40.65 | 3.27 | 38.82 | 38.82 | 3.62 | 35.74 | 35.74 | 3.98 | 32.82 | 32.82 | 4.41 | 29.82 | 29.82 | 4.89 |
| | 62 (17) | 42.53 | 42.53 | 2.96 | 40.70 | 40.70 | 3.27 | 38.86 | 38.86 | 3.62 | 35.78 | 35.78 | 3.98 | 32.86 | 32.86 | 4.41 | 29.85 | 29.85 | 4.89 |
| | 63 (17) | 43.27 | 33.10 | 2.97 | 41.11 | 32.21 | 3.27 | 38.76 | 31.24 | 3.62 | 34.51 | 29.44 | 3.96 | 30.83 | 27.78 | 4.38 | 26.99 | 26.99 | 4.84 |
| | 67 (19) | 46.80 | 34.63 | 3.00 | 44.50 | 33.75 | 3.31 | 42.09 | 32.83 | 3.66 | 39.37 | 31.78 | 4.04 | 34.65 | 29.90 | 4.44 | 30.55 | 28.07 | 4.90 |
| | 72 (22) | 51.83 | 27.42 | 3.05 | 49.36 | 26.56 | 3.36 | 46.75 | 25.67 | 3.72 | 43.98 | 24.73 | 4.11 | 40.93 | 23.70 | 4.55 | 36.05 | 22.10 | 5.00 |

Heating Capacities
PHJ342

| INDOOR AIR | | OUTDOOR COIL ENTERING AIR TEMPERATURES °F (°C) | | | | | | | | | | | | | | | | | | | | | | | |
|------------|-------|--|-------|----------------|---------|--------------|----------------|----------|--------------|----------------|---------|--------------|----------------|---------|--------------|----------------|--------|--------------|----------------|---------|--------------|----------------|---------|--------------|------|
| | | -10 (-23) | | | 0 (-18) | | | 10 (-12) | | | 20 (-7) | | | 30 (-1) | | | 40 (4) | | | 50 (10) | | | 60 (16) | | |
| | | Return Air db °F (°C) | CFM | Capacity MBtuh | | Total Sys kW | Capacity MBtuh | | Total Sys kW | Capacity MBtuh | | Total Sys kW | Capacity MBtuh | | Total Sys kW | Capacity MBtuh | | Total Sys kW | Capacity MBtuh | | Total Sys kW | Capacity MBtuh | | Total Sys kW | |
| Total | Integ | | | Total | Integ | | Total | Integ | | Total | Integ | | Total | Integ | | Total | Integ | | Total | Integ | | Total | Integ | | |
| 65 (18) | 1225 | 12.14 | 11.17 | 2.54 | 16.20 | 14.90 | 2.65 | 20.68 | 18.98 | 2.77 | 25.59 | 23.21 | 2.90 | 31.13 | 27.28 | 3.05 | 37.09 | 37.09 | 3.24 | 42.85 | 42.85 | 3.42 | 49.49 | 49.49 | 3.66 |
| | 1400 | 12.39 | 11.40 | 2.56 | 16.49 | 15.17 | 2.66 | 21.02 | 19.29 | 2.78 | 25.98 | 23.56 | 2.89 | 31.77 | 27.84 | 3.04 | 37.47 | 37.47 | 3.20 | 43.38 | 43.38 | 3.37 | 50.17 | 50.17 | 3.58 |
| | 1575 | 12.62 | 11.61 | 2.58 | 16.72 | 15.38 | 2.68 | 21.29 | 19.54 | 2.78 | 26.30 | 23.86 | 2.89 | 32.51 | 28.49 | 3.04 | 37.84 | 37.84 | 3.17 | 43.84 | 43.84 | 3.33 | 50.78 | 50.78 | 3.53 |
| 70 (21) | 1225 | 11.34 | 10.44 | 2.65 | 15.44 | 14.20 | 2.77 | 19.93 | 18.30 | 2.90 | 24.86 | 22.54 | 3.03 | 30.27 | 26.52 | 3.18 | 36.59 | 36.59 | 3.40 | 42.22 | 42.22 | 3.58 | 48.72 | 48.72 | 3.83 |
| | 1400 | 11.56 | 10.63 | 2.67 | 15.69 | 14.43 | 2.79 | 20.24 | 18.58 | 2.90 | 25.22 | 22.87 | 3.02 | 30.70 | 26.90 | 3.16 | 36.98 | 36.98 | 3.36 | 42.72 | 42.72 | 3.52 | 49.41 | 49.41 | 3.75 |
| | 1575 | 11.77 | 10.83 | 2.70 | 15.95 | 14.67 | 2.80 | 20.54 | 18.85 | 2.91 | 25.57 | 23.19 | 3.02 | 31.12 | 27.27 | 3.15 | 37.32 | 37.32 | 3.33 | 43.18 | 43.18 | 3.48 | 49.98 | 49.98 | 3.69 |
| 75 (24) | 1225 | 10.50 | 9.66 | 2.78 | 14.61 | 13.45 | 2.90 | 19.14 | 17.57 | 3.03 | 24.09 | 21.85 | 3.17 | 29.48 | 25.83 | 3.32 | 36.02 | 36.02 | 3.56 | 41.59 | 41.59 | 3.76 | 47.96 | 47.96 | 4.00 |
| | 1400 | 10.74 | 9.88 | 2.80 | 14.89 | 13.70 | 2.92 | 19.48 | 17.88 | 3.03 | 24.48 | 22.20 | 3.16 | 29.93 | 26.23 | 3.30 | 36.44 | 36.44 | 3.52 | 42.07 | 42.07 | 3.70 | 48.62 | 48.62 | 3.92 |
| | 1575 | 10.95 | 10.08 | 2.83 | 15.16 | 13.95 | 2.93 | 19.78 | 18.16 | 3.04 | 24.81 | 22.50 | 3.16 | 30.33 | 26.57 | 3.29 | 36.81 | 36.81 | 3.49 | 42.52 | 42.52 | 3.65 | 49.20 | 49.20 | 3.87 |

See Legend and Notes on page 15.

PERFORMANCE DATA (CONT.)

Cooling Capacities

PHJ348

| EVAPORATOR AIR | | CONDENSER ENTERING AIR TEMPERATURES °F (°C) | | | | | | | | | | | | | | | | | | |
|----------------|-------------|---|---------|--------------|----------------|-------|--------------|----------------|-------|--------------|----------------|-------|--------------|----------------|-------|--------------|----------------|-------|--------------|--|
| | | 75 (24) | | | 85 (29) | | | 95 (35) | | | 105 (41) | | | 115 (46) | | | 125 (52) | | | |
| | | Capacity MBtuh | | Total Sys kW | Capacity MBtuh | | Total Sys kW | Capacity MBtuh | | Total Sys kW | Capacity MBtuh | | Total Sys kW | Capacity MBtuh | | Total Sys kW | Capacity MBtuh | | Total Sys kW | |
| CFM / BF | EWB °F (°C) | Total | Sens | Total | Sens | Total | Sens | Total | Sens | Total | Sens | Total | Sens | Total | Sens | Total | Sens | Total | Sens | |
| | | 1400 / 0.07 | 57 (14) | 45.20 | 45.20 | 43.33 | 3.55 | 41.34 | 41.34 | 3.95 | 38.12 | 38.12 | 4.35 | 35.13 | 35.13 | 4.81 | 32.15 | 32.15 | 5.34 | |
| 62 (17) | 46.71 | | 41.68 | 40.56 | 3.56 | 39.40 | 39.40 | 3.95 | 38.15 | 38.15 | 4.35 | 35.19 | 35.19 | 4.81 | 32.20 | 32.20 | 5.34 | | | |
| 63 (17) | 47.53 | | 34.01 | 32.92 | 3.56 | 31.77 | 31.77 | 3.96 | 38.58 | 29.94 | 4.36 | 34.57 | 28.26 | 4.80 | 30.67 | 26.63 | 5.30 | | | |
| 1600 / 0.08 | 57 (14) | 50.96 | 35.23 | 34.13 | 3.59 | 45.76 | 33.06 | 3.99 | 42.98 | 31.99 | 4.43 | 38.86 | 30.18 | 4.90 | 34.57 | 28.52 | 5.40 | | | |
| | 62 (17) | 55.43 | 28.68 | 27.63 | 3.62 | 49.88 | 26.55 | 4.04 | 46.91 | 25.38 | 4.49 | 43.79 | 24.21 | 4.97 | 39.86 | 22.94 | 5.50 | | | |
| | 67 (14) | 47.06 | 47.06 | 45.06 | 3.62 | 45.06 | 42.96 | 4.01 | 40.20 | 40.20 | 4.44 | 36.87 | 36.87 | 4.90 | 33.65 | 33.65 | 5.42 | | | |
| 1800 / 0.09 | 57 (14) | 44.55 | 3.22 | 45.42 | 43.39 | 3.61 | 42.99 | 42.99 | 4.01 | 40.27 | 40.27 | 4.45 | 36.93 | 36.93 | 4.90 | 33.71 | 33.71 | 5.42 | | |
| | 63 (17) | 48.45 | 35.96 | 34.89 | 3.61 | 43.34 | 33.74 | 4.01 | 39.68 | 32.11 | 4.43 | 35.40 | 30.31 | 4.86 | 31.36 | 28.61 | 5.36 | | | |
| | 67 (19) | 51.88 | 37.20 | 36.11 | 3.63 | 46.50 | 35.00 | 4.04 | 43.61 | 33.83 | 4.48 | 39.76 | 32.48 | 4.95 | 35.41 | 30.72 | 5.47 | | | |
| 1800 / 0.09 | 72 (22) | 56.33 | 29.83 | 28.78 | 3.67 | 50.61 | 27.67 | 4.09 | 47.54 | 26.48 | 4.54 | 44.33 | 25.28 | 5.02 | 40.46 | 24.19 | 5.55 | | | |
| | 57 (14) | 48.51 | 48.51 | 46.40 | 3.66 | 44.19 | 44.19 | 4.06 | 41.80 | 41.80 | 4.50 | 38.40 | 38.40 | 4.98 | 35.00 | 35.00 | 5.50 | | | |
| | 62 (17) | 46.97 | 46.97 | 46.43 | 3.66 | 44.24 | 44.24 | 4.06 | 41.85 | 41.85 | 4.50 | 38.45 | 38.45 | 4.98 | 35.05 | 35.05 | 5.50 | | | |
| 1800 / 0.09 | 63 (17) | 49.16 | 37.79 | 36.66 | 3.66 | 43.90 | 35.58 | 4.06 | 40.60 | 34.14 | 4.49 | 36.11 | 32.25 | 4.92 | 31.98 | 30.41 | 5.42 | | | |
| | 67 (19) | 52.56 | 39.02 | 37.94 | 3.68 | 49.88 | 37.94 | 4.09 | 44.10 | 35.61 | 4.53 | 40.41 | 34.58 | 5.01 | 36.05 | 32.74 | 5.53 | | | |
| | 72 (22) | 57.00 | 30.86 | 29.81 | 3.71 | 51.17 | 28.67 | 4.14 | 48.00 | 27.47 | 4.59 | 44.74 | 26.23 | 5.07 | 40.90 | 25.30 | 5.60 | | | |

Heating Capacities

PHJ348

| INDOOR AIR | | OUTDOOR COIL ENTERING AIR TEMPERATURES °F (°C) | | | | | | | | | | | | | | | | | | | | | | | |
|-----------------------|-------|--|-------|--------------|----------------|-------|--------------|----------------|-------|--------------|----------------|-------|--------------|----------------|-------|--------------|----------------|-------|--------------|----------------|-------|--------------|----------------|-------|--------------|
| | | -10 (-23) | | | 0 (-18) | | | 10 (-12) | | | 20 (-7) | | | 30 (-1) | | | 40 (4) | | | 50 (10) | | | 60 (16) | | |
| | | Capacity MBtuh | | Total Sys kW | Capacity MBtuh | | Total Sys kW | Capacity MBtuh | | Total Sys kW | Capacity MBtuh | | Total Sys kW | Capacity MBtuh | | Total Sys kW | Capacity MBtuh | | Total Sys kW | Capacity MBtuh | | Total Sys kW | Capacity MBtuh | | Total Sys kW |
| Return Air db °F (°C) | CFM | Total | Integ | Total | Integ | Total | Integ | Total | Integ | Total | Integ | Total | Integ | Total | Integ | Total | Integ | Total | Integ | Total | Integ | Total | Integ | | |
| | | 65 (18) | 1400 | 14.74 | 13.56 | 2.91 | 19.51 | 17.95 | 3.03 | 24.50 | 22.49 | 3.16 | 29.84 | 27.06 | 3.30 | 36.36 | 31.86 | 3.49 | 42.03 | 42.03 | 3.65 | 48.56 | 48.56 | 3.83 | 56.09 |
| 1600 | 14.97 | | 13.78 | 2.93 | 19.78 | 18.20 | 3.05 | 24.81 | 22.77 | 3.17 | 30.21 | 27.40 | 3.29 | 36.69 | 32.15 | 3.47 | 42.45 | 42.45 | 3.61 | 49.14 | 49.14 | 3.77 | 56.41 | 56.41 | 3.93 |
| 1800 | 15.18 | | 13.97 | 2.96 | 20.01 | 18.42 | 3.07 | 25.09 | 23.02 | 3.18 | 30.54 | 27.69 | 3.30 | 36.97 | 32.40 | 3.46 | 42.85 | 42.85 | 3.59 | 49.61 | 49.61 | 3.74 | 56.58 | 56.58 | 3.87 |
| 70 (21) | 1400 | 14.15 | 13.01 | 3.03 | 18.92 | 17.41 | 3.16 | 23.91 | 21.95 | 3.29 | 29.23 | 26.51 | 3.44 | 35.88 | 31.44 | 3.65 | 41.47 | 41.47 | 3.81 | 47.90 | 47.90 | 4.01 | 55.42 | 55.42 | 4.22 |
| | 1600 | 14.38 | 13.23 | 3.06 | 19.20 | 17.66 | 3.17 | 24.23 | 22.24 | 3.30 | 29.61 | 26.85 | 3.43 | 36.25 | 31.76 | 3.62 | 41.91 | 41.91 | 3.77 | 48.47 | 48.47 | 3.95 | 55.82 | 55.82 | 4.12 |
| | 1800 | 14.58 | 13.42 | 3.09 | 19.44 | 17.89 | 3.19 | 24.51 | 22.49 | 3.31 | 29.91 | 27.12 | 3.44 | 36.54 | 32.02 | 3.61 | 42.30 | 42.30 | 3.75 | 48.94 | 48.94 | 3.91 | 56.01 | 56.01 | 4.06 |
| 75 (24) | 1400 | 13.47 | 12.39 | 3.17 | 18.27 | 16.81 | 3.30 | 23.28 | 21.37 | 3.44 | 28.57 | 25.91 | 3.59 | 34.52 | 30.25 | 3.77 | 40.95 | 40.95 | 3.98 | 47.26 | 47.26 | 4.19 | 54.69 | 54.69 | 4.42 |
| | 1600 | 13.71 | 12.61 | 3.20 | 18.55 | 17.07 | 3.31 | 23.59 | 21.66 | 3.44 | 28.95 | 26.25 | 3.58 | 35.67 | 31.25 | 3.78 | 41.38 | 41.38 | 3.94 | 47.82 | 47.82 | 4.13 | 55.19 | 55.19 | 4.32 |
| | 1800 | 13.93 | 12.81 | 3.23 | 18.80 | 17.30 | 3.33 | 23.88 | 21.92 | 3.45 | 29.27 | 26.55 | 3.58 | 36.05 | 31.59 | 3.77 | 41.73 | 41.73 | 3.91 | 48.28 | 48.28 | 4.09 | 55.43 | 55.43 | 4.25 |

See Legend and Notes on page 15.

PERFORMANCE DATA (CONT.)

Cooling Capacities

PHJ360

| EVAPORATOR AIR | | CONDENSER ENTERING AIR TEMPERATURES °F (°C) | | | | | | | | | | | | | | | | | | |
|----------------|-------------|---|---------|--------------|----------------|-------|--------------|----------------|-------|--------------|----------------|-------|--------------|----------------|-------|--------------|----------------|-------|--------------|-------|
| | | 75 (24) | | | 85 (29) | | | 95 (35) | | | 105 (41) | | | 115 (46) | | | 125 (52) | | | |
| | | Capacity MBtuh | | Total Sys kW | Capacity MBtuh | | Total Sys kW | Capacity MBtuh | | Total Sys kW | Capacity MBtuh | | Total Sys kW | Capacity MBtuh | | Total Sys kW | Capacity MBtuh | | Total Sys kW | |
| CFM / BF | EWB °F (°C) | Total | Sens | Total | Sens | Total | Sens | Total | Sens | Total | Sens | Total | Sens | Total | Sens | Total | Sens | Total | Sens | |
| | | 1750 / 0.07 | 57 (14) | 54.52 | 54.52 | 4.20 | 52.33 | 52.33 | 4.64 | 49.95 | 49.95 | 5.15 | 47.38 | 47.38 | 5.72 | 44.60 | 44.60 | 6.38 | 41.59 | 41.59 |
| 62 (17) | 56.27 | | 50.77 | 4.22 | 53.60 | 49.30 | 4.66 | 50.80 | 47.71 | 5.16 | 47.84 | 45.93 | 5.73 | 44.67 | 44.67 | 6.38 | 41.64 | 41.64 | 7.13 | 7.13 |
| 63* (17) | 56.95 | | 41.26 | 4.23 | 54.26 | 39.89 | 4.67 | 51.36 | 38.44 | 5.17 | 48.25 | 36.89 | 5.74 | 44.95 | 44.95 | 6.38 | 41.42 | 41.42 | 7.12 | 7.12 |
| 2000 / 0.08 | 67 (19) | 61.09 | 42.88 | 4.29 | 58.15 | 41.49 | 4.74 | 55.00 | 40.00 | 5.24 | 51.65 | 38.45 | 5.80 | 48.09 | 48.09 | 6.45 | 44.32 | 44.32 | 7.18 | 7.18 |
| | 72 (22) | 66.41 | 34.97 | 4.38 | 63.15 | 33.61 | 4.83 | 59.71 | 32.21 | 5.33 | 56.05 | 30.72 | 5.89 | 52.18 | 52.18 | 6.53 | 48.10 | 48.10 | 7.26 | 7.26 |
| | 57 (14) | 56.68 | 56.68 | 4.29 | 54.29 | 54.29 | 4.73 | 51.73 | 51.73 | 5.24 | 48.97 | 48.97 | 5.81 | 46.00 | 46.00 | 6.47 | 42.79 | 42.79 | 7.21 | 7.21 |
| 2250 / 0.09 | 62 (17) | 57.54 | 54.21 | 4.30 | 54.80 | 52.58 | 4.74 | 51.96 | 50.72 | 5.24 | 49.03 | 49.03 | 5.81 | 46.05 | 46.05 | 6.47 | 42.84 | 42.84 | 7.21 | 7.21 |
| | 63 (17) | 58.11 | 43.67 | 4.31 | 55.28 | 42.25 | 4.75 | 52.24 | 40.72 | 5.24 | 49.00 | 39.11 | 5.81 | 45.56 | 45.56 | 6.45 | 41.91 | 41.91 | 7.19 | 7.19 |
| | 67 (19) | 62.22 | 45.44 | 4.37 | 59.12 | 43.99 | 4.82 | 55.82 | 42.46 | 5.31 | 52.33 | 40.83 | 5.88 | 48.65 | 48.65 | 6.52 | 44.74 | 44.74 | 7.24 | 7.24 |
| 2250 / 0.09 | 72 (22) | 67.55 | 36.49 | 4.46 | 64.13 | 35.07 | 4.91 | 60.55 | 33.62 | 5.40 | 56.77 | 32.08 | 5.97 | 52.77 | 52.77 | 6.60 | 48.56 | 48.56 | 7.32 | 7.32 |
| | 57 (14) | 58.41 | 58.41 | 4.38 | 55.86 | 55.86 | 4.82 | 53.14 | 53.14 | 5.32 | 50.22 | 50.22 | 5.90 | 47.08 | 47.08 | 6.55 | 43.72 | 43.72 | 7.28 | 7.28 |
| | 62 (17) | 58.68 | 57.16 | 4.38 | 55.91 | 55.91 | 4.82 | 53.20 | 53.20 | 5.33 | 50.28 | 50.28 | 5.90 | 47.13 | 47.13 | 6.55 | 43.76 | 43.76 | 7.28 | 7.28 |
| 2250 / 0.09 | 63 (17) | 58.96 | 45.93 | 4.38 | 56.01 | 44.46 | 4.82 | 52.86 | 42.90 | 5.32 | 49.50 | 41.22 | 5.88 | 45.99 | 45.99 | 6.52 | 42.28 | 42.28 | 7.25 | 7.25 |
| | 67 (19) | 63.00 | 47.85 | 4.44 | 59.77 | 46.34 | 4.89 | 56.38 | 44.78 | 5.38 | 52.77 | 43.10 | 5.94 | 49.00 | 49.00 | 6.58 | 45.05 | 45.05 | 7.30 | 7.30 |
| | 72 (22) | 68.37 | 37.89 | 4.53 | 64.84 | 36.45 | 4.98 | 61.16 | 34.96 | 5.48 | 57.25 | 33.36 | 6.04 | 53.15 | 53.15 | 6.67 | 48.87 | 48.87 | 7.39 | 7.39 |

Heating Capacities

PHJ360

| INDOOR AIR | | OUTDOOR COIL ENTERING AIR TEMPERATURES °F (°C) | | | | | | | | | | | | | | | | | | | | | | | |
|-----------------------|-------|--|-------|--------------|----------------|-------|--------------|----------------|-------|--------------|----------------|-------|--------------|----------------|-------|--------------|----------------|-------|--------------|----------------|-------|--------------|----------------|-------|--------------|
| | | -10 (-23) | | | 0 (-18) | | | 10 (-12) | | | 20 (-7) | | | 30 (-1) | | | 40 (4) | | | 50 (10) | | | 60 (16) | | |
| | | Capacity MBtuh | | Total Sys kW | Capacity MBtuh | | Total Sys kW | Capacity MBtuh | | Total Sys kW | Capacity MBtuh | | Total Sys kW | Capacity MBtuh | | Total Sys kW | Capacity MBtuh | | Total Sys kW | Capacity MBtuh | | Total Sys kW | Capacity MBtuh | | Total Sys kW |
| Return Air db °F (°C) | CFM | Total | Integ | Total | Integ | Total | Integ | Total | Integ | Total | Integ | Total | Integ | Total | Integ | Total | Integ | Total | Integ | Total | Integ | Total | Integ | | |
| | | 65 (18) | 1750 | 18.85 | 17.34 | 3.59 | 24.42 | 22.47 | 3.74 | 30.31 | 27.82 | 3.89 | 36.67 | 33.26 | 4.05 | 44.81 | 39.26 | 4.27 | 51.11 | 51.11 | 4.41 | 57.40 | 57.40 | 4.57 | 64.43 |
| 2000 | 19.17 | | 17.64 | 3.63 | 24.78 | 22.80 | 3.77 | 30.70 | 28.18 | 3.90 | 37.14 | 33.68 | 4.05 | 45.15 | 39.56 | 4.24 | 51.28 | 51.28 | 4.36 | 57.44 | 57.44 | 4.50 | 64.37 | 64.37 | 4.67 |
| 2250 | 19.46 | | 17.90 | 3.67 | 25.09 | 23.09 | 3.80 | 31.05 | 28.49 | 3.93 | 37.55 | 34.05 | 4.06 | 45.29 | 39.68 | 4.23 | 51.40 | 51.40 | 4.34 | 57.42 | 57.42 | 4.47 | 64.21 | 64.21 | 4.61 |
| 70 (21) | 1750 | 17.97 | 16.54 | 3.74 | 23.63 | 21.75 | 3.91 | 29.57 | 27.14 | 4.07 | 35.90 | 32.56 | 4.23 | 44.24 | 38.77 | 4.48 | 50.62 | 50.62 | 4.62 | 56.88 | 56.88 | 4.79 | 63.78 | 63.78 | 4.99 |
| | 2000 | 18.29 | 16.83 | 3.78 | 23.99 | 22.07 | 3.93 | 29.96 | 27.50 | 4.08 | 36.36 | 32.98 | 4.22 | 44.70 | 39.17 | 4.44 | 50.85 | 50.85 | 4.57 | 56.96 | 56.96 | 4.72 | 63.74 | 63.74 | 4.89 |
| | 2250 | 18.58 | 17.10 | 3.82 | 24.31 | 22.37 | 3.96 | 30.31 | 27.82 | 4.10 | 36.76 | 33.34 | 4.23 | 44.98 | 39.41 | 4.42 | 50.96 | 50.96 | 4.55 | 56.97 | 56.97 | 4.68 | 63.66 | 63.66 | 4.83 |
| 75 (24) | 1750 | 17.07 | 15.71 | 3.90 | 22.79 | 20.97 | 4.08 | 28.78 | 26.41 | 4.25 | 35.10 | 31.83 | 4.42 | 42.45 | 37.20 | 4.63 | 50.18 | 50.18 | 4.84 | 56.35 | 56.35 | 5.02 | 63.13 | 63.13 | 5.22 |
| | 2000 | 17.37 | 15.98 | 3.94 | 23.15 | 21.30 | 4.10 | 29.18 | 26.78 | 4.26 | 35.55 | 32.24 | 4.41 | 43.17 | 37.83 | 4.61 | 50.40 | 50.40 | 4.79 | 56.46 | 56.46 | 4.94 | 63.14 | 63.14 | 5.12 |
| | 2250 | 17.65 | 16.24 | 3.98 | 23.47 | 21.59 | 4.13 | 29.53 | 27.10 | 4.28 | 35.95 | 32.60 | 4.42 | 44.25 | 38.77 | 4.64 | 50.52 | 50.52 | 4.76 | 56.49 | 56.49 | 4.90 | 63.12 | 63.12 | 5.06 |

See Legend and Notes on page 15.

PERFORMANCE DATA (CONT.)

LEGEND

- BF— Bypass Factor
 db — Dry Bulb
 edb— Entering Dry— Bulb
 Ewb — Entering Wet— Bulb
 kW — Total Unit Power Input
 ldb— Leaving Dry— Bulb
 lwb— Leaving Wet— Bulb
 SHC — Sensible Heat Capacity (1000 Btuh)
 TC — Total Capacity (1000 Btuh) (net)

* At 75°F (23.9°C) entering dry bulb (Tennessee Valley Authority [TVA] rating conditions); all other at 80°F (26.75°C) entering dry bulb.

COOLING NOTES:

1. Ratings are net; they account for the effects of the evaporator—fan motor power and heat.
2. Direct interpolation is permissible. Do not extrapolate.
3. The following formulas may be used:

$$t_{ldb} = t_{edb} - \frac{\text{Sensible capacity (Btuh)}}{1.10 \times \text{CFM}}$$

$$t_{lwb} = \frac{\text{Wet-bulb temperature corresponding to enthalpy}}{\text{air leaving evaporator coil } (t_{lwb})} = \frac{\text{total capacity (Btuh)}}{4.5 \times \text{CFM}}$$

Where: t_{lwb} = Enthalpy of air entering evaporator coil

4. The SHC is based on 80°F (26.7°C) edb temperature of air entering evaporator coil. Below 80°F (26.7°C) edb, subtract (corr factor x CFM) from SHC. Above 80°F (26.7°C) edb, add (corr factor x CFM) to SHC.

Correction Factor = $1.10 \times (1 - \text{BF}) \times (\text{edb} + 80)$.

| Filter Pressure Drop (IN. W.C.) | | | | | | | | | | | | | | | | | | | |
|---------------------------------|-----------------------------|------|------|------|------|------|------|------|------|------|------|------|------|------|------|------|------|------|------|
| UNIT SIZE PHJ3 | FILTER SIZE in. (mm) | 500 | 600 | 700 | 800 | 900 | 1000 | 1100 | 1200 | 1300 | 1400 | 1500 | 1600 | 1700 | 1800 | 1900 | 2000 | 2100 | 2200 |
| 24 | 20x20x1 (508x508 x25) | 0.06 | 0.07 | 0.08 | 0.10 | 0.12 | 0.13 | 0.14 | 0.15 | — | — | — | — | — | — | — | — | — | — |
| 30 | 20x24x1 (508x610 x25) | — | — | — | 0.08 | 0.09 | 0.10 | 0.11 | 0.13 | 0.14 | 0.15 | 0.16 | — | — | — | — | — | — | — |
| 36 – 42 | 24x30x1 (610x762 x25) | — | — | — | 0.04 | 0.05 | 0.06 | 0.07 | 0.07 | 0.08 | 0.09 | 0.10 | — | — | — | — | — | — | — |
| 48 – 60 | 24x36x1 (610x914 x25) | — | — | — | — | — | — | — | 0.06 | 0.07 | 0.07 | 0.08 | 0.09 | 0.09 | 0.10 | 0.11 | 0.12 | 0.13 | 0.14 |

| Accessory Electric Heat Pressure Drop (IN. W.C.) | | | | | | | | |
|--|-------|-------|-------|-------|-------|-------|-------|-------|
| HEATER kW | CFM | | | | | | | |
| | 800 | 1000 | 1200 | 1400 | 1600 | 1800 | 2000 | 2200 |
| 5–20 | 0.033 | 0.037 | 0.042 | 0.047 | 0.052 | 0.060 | 0.067 | 0.075 |

| Wet Coil Delivery*— (Deduct 10% for 208-Volt Operation) | | | | | | | | | | | | |
|---|-----------|------------------------------|-------------------------------------|------|------|------|------|------|------|------|------|------|
| 230 VOLT HORIZONTAL DISCHARGE | | | | | | | | | | | | |
| UNIT PHJ3 | SPEED TAP | AIR DELIVERY ² | EXTERNAL STATIC PRESSURE (IN. W.C.) | | | | | | | | | |
| | | | 0.1 | 0.2 | 0.3 | 0.4 | 0.5 | 0.6 | 0.7 | 0.8 | 0.9 | 1.0 |
| 24 | 1 | CFM | 933 | 799 | 758 | 707 | 675 | 608 | 549 | 497 | 435 | 394 |
| | 2 | CFM | 1016 | 921 | 882 | 854 | 809 | 761 | 711 | 668 | 599 | 552 |
| | 3 | CFM | 1079 | 1041 | 1003 | 970 | 944 | 909 | 866 | 810 | 764 | 724 |
| 30 | 1 | CFM | 1052 | 1018 | 984 | 943 | 914 | 879 | 833 | 795 | 732 | 678 |
| | 2 | CFM | 1141 | 1107 | 1069 | 1036 | 1006 | 974 | 932 | 899 | 856 | 784 |
| | 3 | CFM | 1246 | 1213 | 1181 | 1144 | 1108 | 1078 | 1043 | 1015 | 973 | 931 |
| 36 | 1 | CFM | 1311 | 1253 | 1195 | 1136 | 1083 | 1023 | 958 | 895 | 818 | 729 |
| | 2 | CFM | 1413 | 1364 | 1313 | 1256 | 1203 | 1148 | 1084 | 1022 | 969 | 882 |
| | 3 | CFM | 1571 | 1525 | 1473 | 1423 | 1364 | 1313 | 1261 | 1210 | 1156 | 1090 |
| 42 | 1 | CFM | 1499 | 1434 | 1394 | 1349 | 1307 | 1273 | 1232 | 1169 | 1108 | 1038 |
| | 2 | CFM | 1568 | 1532 | 1497 | 1459 | 1407 | 1381 | 1346 | 1304 | 1252 | 1185 |
| | 3 | CFM | 1635 | 1593 | 1560 | 1523 | 1484 | 1439 | 1406 | 1369 | 1335 | 1264 |
| 48 | 1 | CFM | 1657 | 1625 | 1590 | 1554 | 1517 | 1486 | 1448 | 1417 | 1381 | 1340 |
| | 2 | CFM | 1707 | 1673 | 1644 | 1614 | 1586 | 1549 | 1515 | 1479 | 1449 | 1407 |
| | 3 | CFM | 1931 | 1900 | 1870 | 1840 | 1809 | 1778 | 1749 | 1714 | 1683 | 1646 |
| 60 | 1 | CFM | 1837 | 1798 | 1753 | 1716 | 1677 | 1637 | 1590 | 1549 | 1497 | 1445 |
| | 2 | CFM | 1910 | 1872 | 1835 | 1795 | 1748 | 1711 | 1673 | 1623 | 1568 | 1525 |
| | 3 | CFM | 2098 | 2065 | 2032 | 1996 | 1956 | 1917 | 1877 | 1839 | 1798 | 1753 |

*Air delivery values are based on operating voltage of 230v, wet coil, without filter or electric heater. Deduct filter and electric heater pressure drops to obtain static pressure available for ducting.

NOTES:

1. Do not operate the unit at a cooling airflow that is less than 350 cfm for each 12,000 Btuh of rated cooling capacity. Evaporator coil frosting may occur at airflows below this point.
2. Standard Cubic Feet per Minute.

| ELECTRICAL DATA | | | | | | | | | | | | | |
|-----------------|--------------|-------|-----|------|-------|-----|-----|-----------|------|------|-------|-------|---------|
| UNIT PHJ3 | V-PH-HZ | RANGE | | | | OFM | IFM | NOMINAL | FLA | | MCA | | MOCP ** |
| | | MIN | MAX | RLA | LRA | FLA | FLA | kW * | 208 | 240 | 208 | 230 | |
| 24 | 208/230-1-60 | 197 | 253 | 12.8 | 58.3 | 0.9 | 2.8 | -/- | - | - | 19.7 | 19.7 | 30 |
| | | | | | | | | 3.8/5 | 18.0 | 20.8 | 42.2 | 45.7 | 45/50 |
| | | | | | | | | 5.6/7.5 | 27.0 | 31.3 | 53.5 | 58.8 | 60/60 |
| | | | | | | | | 7.5/10 | 36.1 | 41.7 | 64.8 | 71.8 | 70/80 |
| 30 | 208/230-1-60 | 197 | 253 | 14.1 | 73.0 | 0.9 | 2.8 | -/- | - | - | 21.3 | 21.3 | 30 |
| | | | | | | | | 3.8/5 | 18.0 | 20.8 | 43.8 | 47.3 | 45/50 |
| | | | | | | | | 5.6/7.5 | 27.0 | 31.3 | 55.1 | 60.5 | 60/70 |
| | | | | | | | | 7.5/10 | 36.1 | 41.7 | 66.5 | 73.5 | 70/80 |
| 36 | 208/230-1-60 | 197 | 253 | 16.7 | 79.0 | 1.5 | 4.1 | -/- | - | - | 26.5 | 26.5 | 40 |
| | | | | | | | | 3.8/5 | 18.0 | 20.8 | 49.0 | 52.5 | 50/60 |
| | | | | | | | | 5.6/7.5 | 27.0 | 31.3 | 60.2 | 65.6 | 70/70 |
| | | | | | | | | 7.5/10 | 36.1 | 41.7 | 71.6 | 78.6 | 80/80 |
| 42 | 208/230-1-60 | 197 | 253 | 18.2 | 112.0 | 1.5 | 4.1 | -/- | - | - | 28.3 | 28.3 | 40 |
| | | | | | | | | 3.8/5 | 18.0 | 20.8 | 50.8 | 54.3 | 60/60 |
| | | | | | | | | 5.6/7.5 | 27.0 | 31.3 | 62.0 | 67.4 | 70/70 |
| | | | | | | | | 7.5/10 | 36.1 | 41.7 | 73.4 | 80.4 | 80/90 |
| 48 | 208/230-1-60 | 197 | 253 | 22.3 | 117.0 | 1.5 | 6.0 | -/- | - | - | 35.4 | 35.4 | 50 |
| | | | | | | | | 3.8/5 | 18.0 | 20.8 | 57.9 | 61.4 | 60/70 |
| | | | | | | | | 5.6/7.5 | 27.0 | 31.3 | 69.1 | 74.5 | 70/80 |
| | | | | | | | | 7.5/10 | 36.1 | 41.7 | 80.5 | 87.5 | 90/90 |
| 60 | 208/230-1-60 | 197 | 253 | 26.4 | 134.0 | 1.9 | 7.6 | -/- | - | - | 42.5 | 42.5 | 60 |
| | | | | | | | | 3.8/5 | 18.0 | 20.8 | 65.0 | 68.5 | 70/70 |
| | | | | | | | | 5.6/7.5 | 27.0 | 31.3 | 76.3 | 81.6 | 80/90 |
| | | | | | | | | 7.5/10 | 36.1 | 41.7 | 87.6 | 94.6 | 90/100 |
| | | | | | | | | 11.3/15 | 54.1 | 62.5 | 110.1 | 120.6 | 125/125 |
| | | | | | | | | 15.0/20.0 | 72.1 | 83.3 | 132.6 | 146.6 | 150/150 |

* kW @ 208/240

** HACR Type Circuit breaker

LEGEND

FLA – Full Load Amps

LRA – Locked Rotor Amps

MCA – Minimum Circuit Amps

MOCP – Maximum Overcurrent Protection

RLA – Rated Load Amps

NOTES:

1. In compliance with NEC (National Electrical Code) requirements for multimotor and combination load equipment (refer to NEC Articles 430 and 440), the overcurrent protective device for the unit shall be Power Supply fuse. The CGA (Canadian Gas Association) units may be fuse or circuit breaker.

2. Minimum wire size is based on 60°C copper wire. If other than 60°C wire is used, or if length exceeds wire length in table, determine size from NEC.

*Heater capacity (kW) based on heater voltage of 208v & 240v. If power distribution voltage to unit varies from rated heater voltage, heater kW will vary accordingly.

TYPICAL INSTALLATION

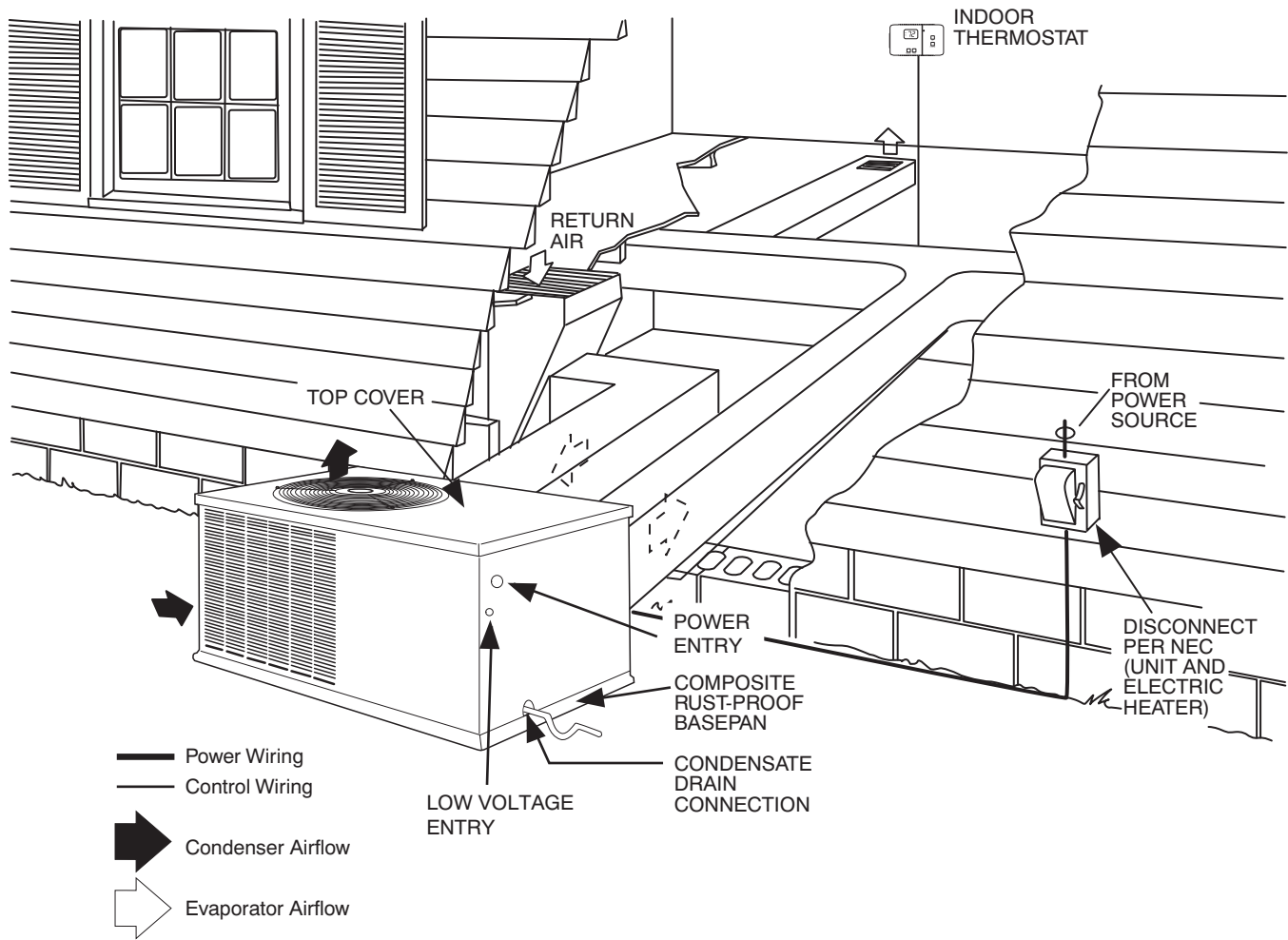

TYPICAL CONNECTION WIRING SCHEMATIC 208/230-1-60

CONNECTION WIRING DIAGRAM

DANGER: ELECTRICAL SHOCK HAZARD DISCONNECT POWER BEFORE SERVICING

USE COPPER CONDUCTORS ONLY
FIELD SUPPLY POWER
208/230 VAC, 60 HZ, 1PH

UNIT ONLY
MAXIMUM WIRE
SIZE 2 AWG.

FOR WIRING WITH
ELECTRIC HEATERS
SEE SCHEMATIC
ON HEATER ACCESSORY.

24 Volt
Thermostat
Connections

ACCESSORY
ELECTRIC HEAT
24 Volt
Thermostat
Connections
(SEE NOTE 7)

ACCESSORY ELECTRIC HEAT
(24 VOLT HEATER RELAY CONNECTIONS)

UNIT COMPONENT ARRANGEMENT

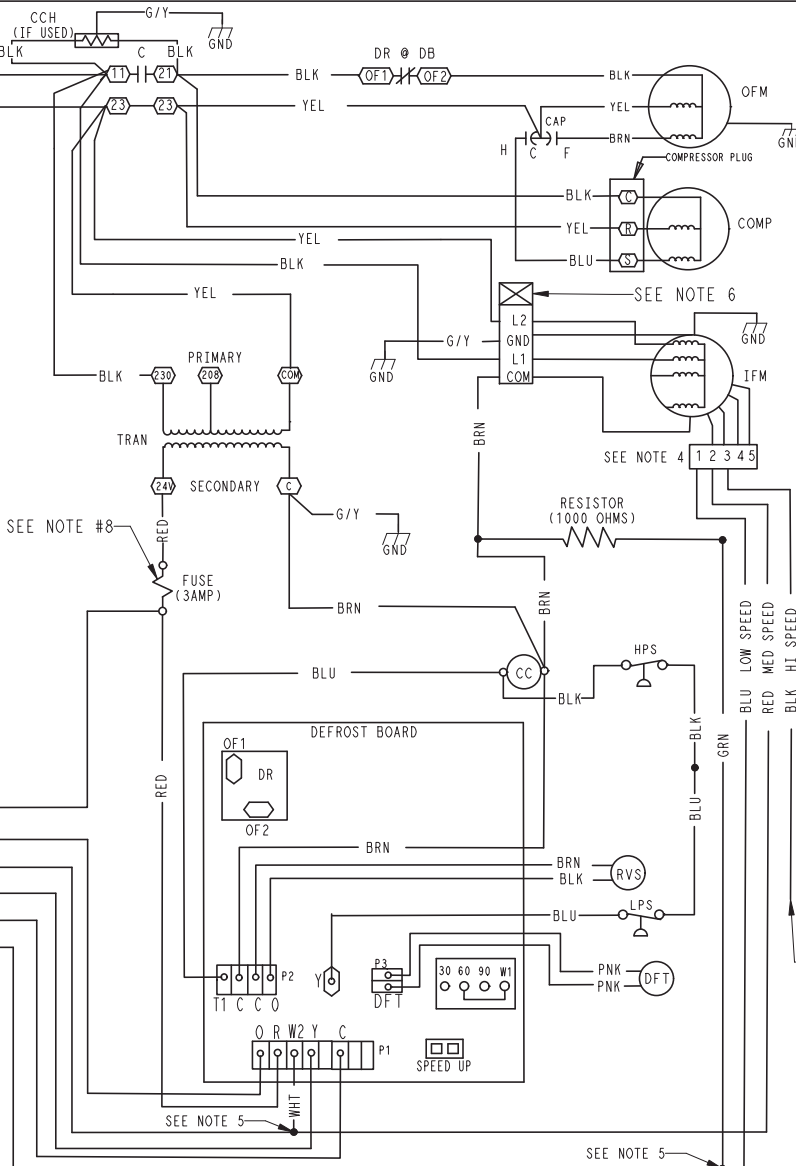
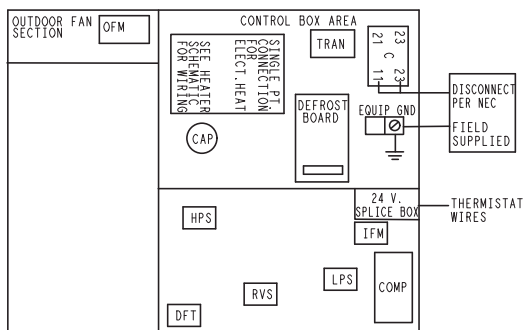

- R — RED
- O — ORN
- W2 — WHT
- Y — YEL
- C — BRN
- G — GRN

- W3 — PNK
- W3 — VIO
- W2 — GRY
- W2 — WHT
- C — BRN

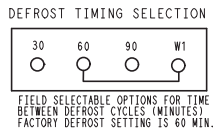
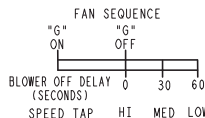

COLOR CODE

- BLK BLACK
- BLU BLUE
- BRN BROWN
- GRN GREEN
- GRY GREY
- G/Y GREEN/YELLOW
- ORN ORANGE
- PNK PINK
- RED RED
- WHT WHITE
- VIO VIOLET
- YEL YELLOW

LEGEND

- △ FIELD SPLICE
- TERMINAL (MARKED)
- TERMINAL (UNMARKED)
- SPLICE
- FACTORY WIRING
- - - FIELD CONTROL WIRING
- - - FIELD POWER WIRING
- - - ACCESSORY OR OPTIONAL WIRING
- C CONTACTOR
- CAP CAPACITOR
- CC CONTACTOR COIL
- CCH CRANK CASE HEATER
- COMP COMPRESSOR MOTOR
- DB DEFROST BOARD
- DFT DEFROST THERMOSTAT
- DR DEFROST RELAY
- GND GROUND
- HR HEATER RELAY
- IFM INDOOR FAN MOTOR
- LPS LOW PRESSURE SWITCH
- HPS HIGH PRESSURE SWITCH
- OFM OUTDOOR FAN MOTOR
- PLUG PLUG
- RVS REVERSING VALVE SOLENOID
- TRAN TRANSFORMER

NOTES:

1. IF ANY OF THE ORIGINAL WIRES FURNISHED ARE REPLACED, IT MUST BE REPLACED WITH THE SAME TYPE OF WIRE OR IT'S EQUIVALENT.
2. USE CONDUCTORS SUITABLE FOR AT LEAST 75°C (167°F) FOR FIELD INSTALLATION.
3. FACTORY WIRING FOR SPEED SELECTOR PLUG.
4. CHANGING OF SPEED TAPS MAY BE REQUIRED WHEN USING FIELD INSTALLED ELECTRIC HEATERS. CONSULT INSTALLATION INSTRUCTIONS TO DETERMINE CORRECT SPEED TAP SETTING.
5. *DO NOT DISCONNECT PLUG UNDER LOAD.*
6. MULTI-STAGE HEATER SHOWN. SINGLE STAGE HEATERS HAVE WHITE AND BROWN WIRES ONLY.
7. FUSE MANUFACTURED BY LITTELFUSE, P/N 257003.

TYPICAL LADDER WIRING SCHEMATIC 208/230-1-60

LADDER WIRING DIAGRAM

DANGER: ELECTRICAL SHOCK HAZARD DISCONNECT POWER BEFORE SERVICING

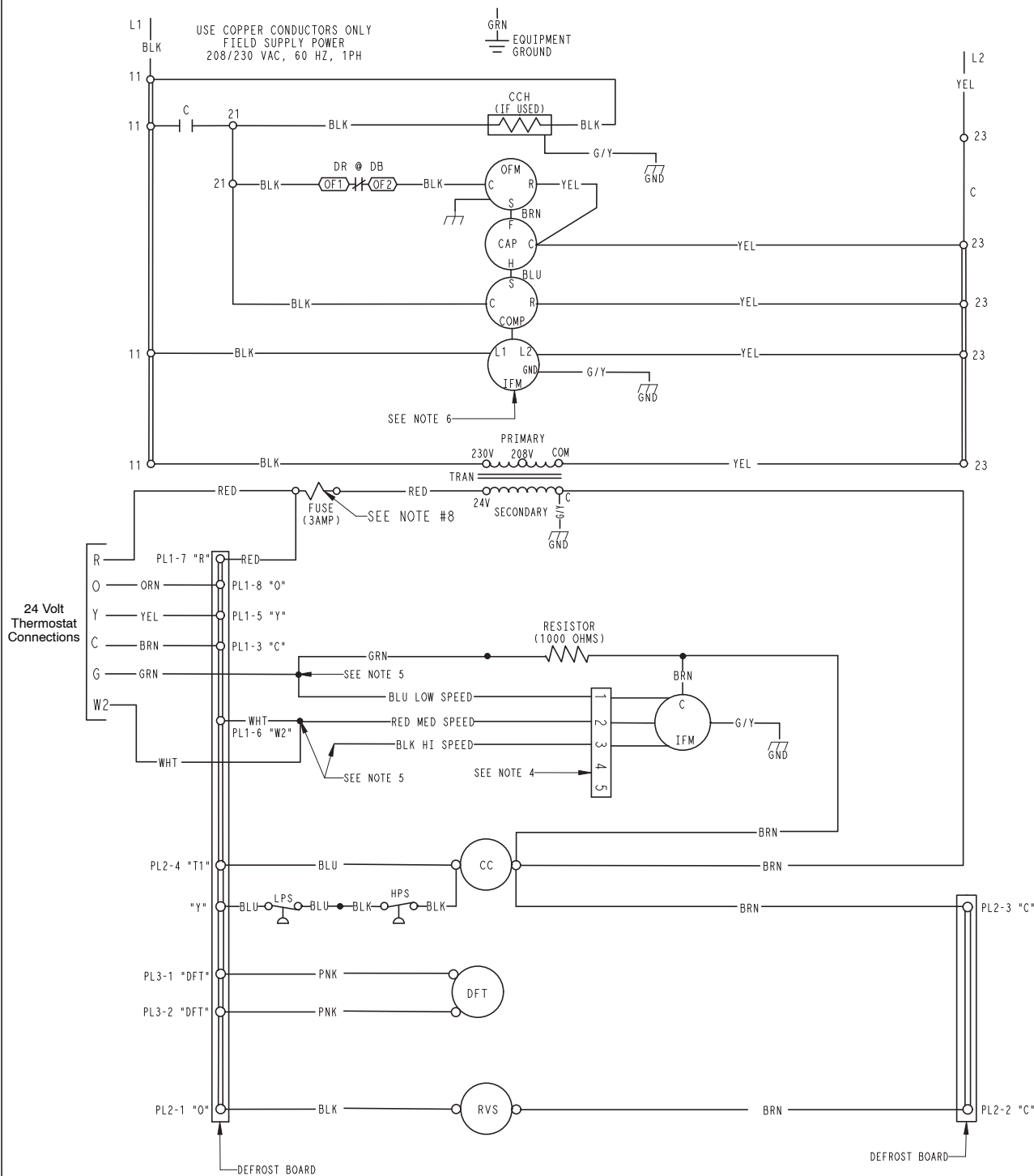

50ZH500517 A

TYPICAL FIELD WIRING

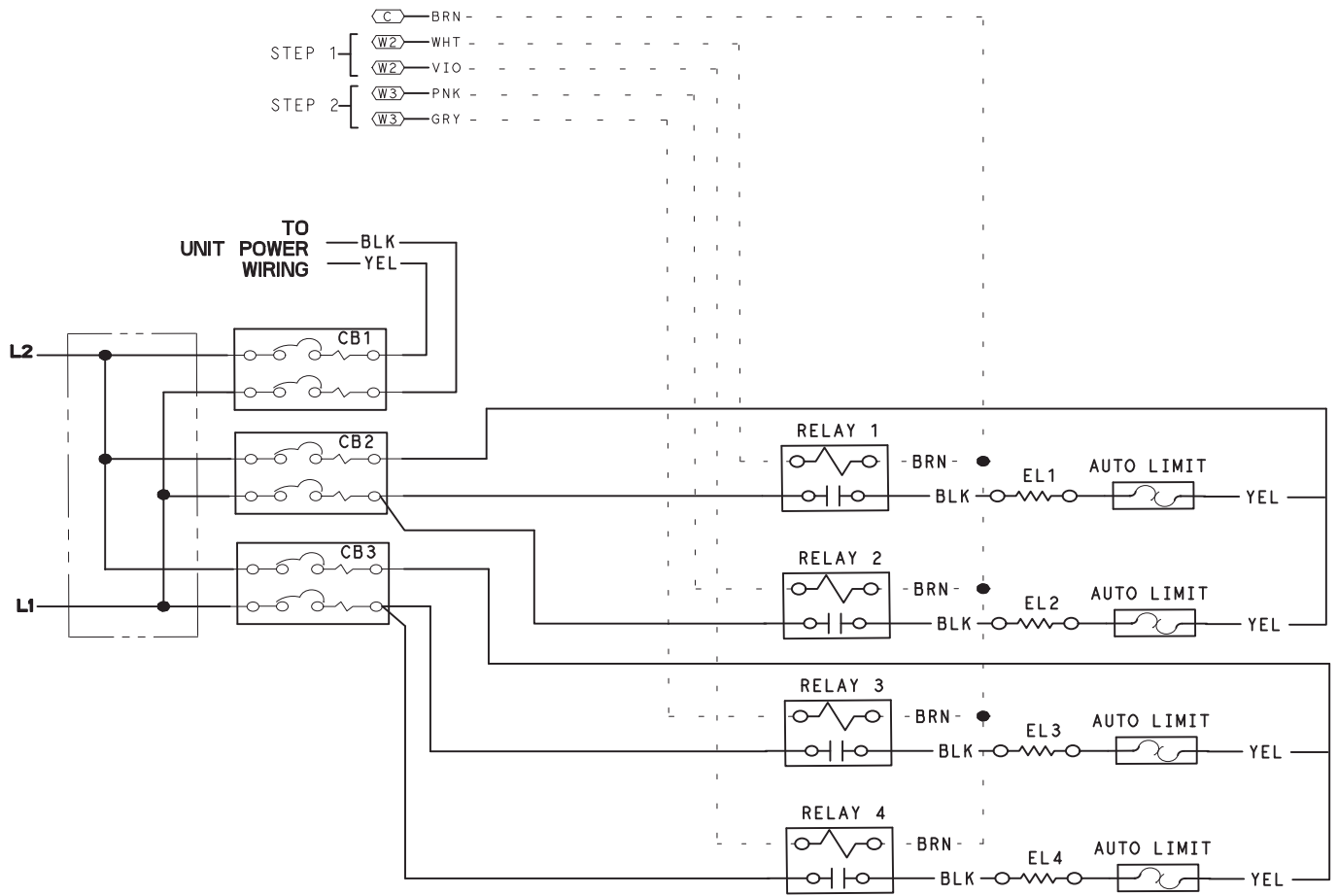

Note: 20 kW shown. Smaller heater have fewer elements and controls.

CONTROLS

Sequence of operation

When power is supplied to unit, the transformer (TRAN) is energized.

Cooling Operation — With a call for cooling (O,Y,G), the reversing valve, contactor, and indoor fan are energized. When the cooling demand is met, Y and G are de-energized, shutting off the contactor (compressor, outdoor fan). The indoor fan stops after a 60 second delay.

Heating Operation — With a call for heating (Y,G), the contactor and indoor fan are energized. When the heating demand is met, Y and G are de-energized, shutting off the contactor (compressor, outdoor fan). The indoor fan stops after a 60 second delay.

Continuous Fan — With the continuous indoor fan option selected on the thermostat, G is continuously energized keeping the indoor fan running at all times.

Defrost — The defrost control is a time/temperature control which includes a field-selectable time period between defrost cycles of 30, 60, and 90 minutes. Electronic timer and defrost cycle start only when contactor is energized and defrost thermostat (DFT) is closed.

Defrost mode is identical to cooling mode, except outdoor fan motor stops and a bank of optional electric heat turns on to warm air supplying the conditioned space.

APPLICATION DATA

Condensate trap — A 2-in. (51 mm) condensate trap must be field supplied.

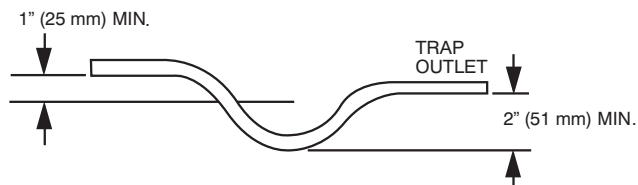

Maximum cooling airflow — To minimize the possibility of condensate blow-off from the evaporator, airflow through the units should not exceed 450 CFM/ton.

Minimum cooling airflow — The minimum cooling airflow is 350 cfm/ton.

Minimum cooling operating outdoor air temperature — All standard units have a minimum ambient operating temperature of 40°F (4.4°C). With accessory low ambient temperature kit, units can operate at temperatures down to 0°F (-17.8°C).

Maximum operating outdoor air temperature — Maximum outdoor operating air temperature for cooling is 125°F (51.7°C).

| PHJ3 ACCESSORIES | | |
|------------------------|---|----------|
| Accessory Model Number | Description | Use With |
| CPLOWAMB001A00 | Low Ambient Control – enables cooling system to operate down to 0 Deg. F by cycling condenser fan on and off. | ALL |
| CPHSTART002A00 | Compressor Start Kit | ALL |
| CPCRKHTR007A00 | 240V Crankcase Heater | 24 – 36 |
| NPCRKHTR004A00 | | 42 – 60 |

| ELECTRIC HEATERS | | | | |
|------------------------|------------------|--------|-----------------|----------|
| Accessory Model Number | Nominal Capacity | Stages | Circuit Breaker | Use With |
| CPHEATER125A00 | 3.8 / 5.0 | 1 | NO | 24 – 42 |
| CPHEATER126A00 | 3.8 / 5.0 | 1 | YES | ALL |
| CPHEATER127A00 | 5.6 / 7.5 | 2 | NO | 24 |
| CPHEATER128A00 | 5.6 / 7.5 | 2 | YES | ALL |
| CPHEATER130A00 | 7.5 / 10.0 | 2 | YES | ALL |
| CPHEATER131A00 | 11.3 / 15.0 | 2 | YES | 36 – 60 |
| CPHEATER132A00 | 15.0 / 20.0 | 2 | YES | 48 – 60 |

Note: If installing an accessory heater, the thermostat must have capability to energize "G" (fan) on a call for "W" (strip heat).

| Multiplication Factors | | |
|------------------------|----------------------|-----------------------|
| HEATER kW RATING | VOLTAGE DISTRIBUTION | MULTIPLICATION FACTOR |
| 240 | 200 | .69 |
| | 208 | .75 |
| | 230 | .92 |
| | 240 | 1.00 |

Example: 15.0 kW (at 240v) heater on 208v
= 15.0 (.75 mult factor)
= 11.25 capacity at 208v

GUIDE SPECIFICATIONS

SMALL PACKAGED PRODUCT AIR-TO-AIR HEAT PUMP CONSTANT VOLUME APPLICATION

HVAC GUIDE SPECIFICATIONS

SIZE RANGE: 2 TO 5 TONS, NOMINAL (COOLING)

MODEL NUMBER: PHJ3

PART I – GENERAL

SYSTEM DESCRIPTION

Outdoor packaged, electrically controlled, air-to-air heat pump utilizing a scroll compressor for heating and cooling duty. Unit shall discharge supply air horizontally as shown on contract drawings.

QUALITY ASSURANCE

- A. Unit shall be rated in accordance with AHRI Standards 210/240, and 270. Designed in accordance with UL Standard 1995.**
- B. Unit shall be designed to conform to ASHRAE 15.**
- C. Unit shall be UL listed as a total package for safety requirements.**
- D. Insulation and adhesive shall meet NFPA 90A requirements for flame spread and smoke generation.**

DELIVERY, STORAGE, AND HANDLING

Unit shall be stored and handled per manufacturer's recommendations.

PART 2– PRODUCTS

EQUIPMENT

A. General:

Factory-assembled, single piece, air-to-air heat pump. Contained within the unit enclosure shall be all factory wiring, piping, controls, and refrigerant charge (R-410A).

B. Unit Cabinet:

1. Unit cabinet shall be constructed of phosphated, bonderized, zinc-coated, prepainted steel.
2. Basepan shall be made of a single-piece non-corrosive, composite material.
3. Indoor fan compartment cabinet surfaces shall be insulated with a minimum 1/2 in. (12.7 mm) thick, flexible insulation, coated on the air side, with aluminum foil-faced insulation.
4. Cabinet panels shall be easily removable for servicing.
5. Unit shall have a factory-installed, sloped, noncorrosive, condensate drain.
6. Unit insulation conforms to ASHRAE 62P.

C. Fans:

1. Indoor Blower (Indoor Fan):
 - a. Fan shall be multispeed, direct drive as shown on the equipment drawings.
 - b. Fan wheel shall be made from steel, be double-inlet type. It shall have forward-curved blades with a corrosion-resistant finish and shall be dynamically balanced.
2. Outdoor fan shall be of the direct-driven propeller type with aluminum blades, riveted to corrosion-resistant steel spiders. It shall be dynamically balanced, and shall discharge air upwards.

D. Compressor:

Fully-hermetic scroll type with external vibration isolation.

E. Coils:

1. Indoor and outdoor coils shall have aluminum-plate fins mechanically bonded to seamless copper tubes with all joints brazed.
2. Tube sheet openings shall be bellied to prevent tube wear.
3. Outdoor coil shall be protected by metal louvered panels.

F. Refrigerant Components:

1. TXV and AccuRater feed system.
2. Service gauge connections on suction and discharge lines.
3. Equipped with liquid line filter drier.
4. Equipped with accumulators on all sizes.

G. Controls and Safeties:

1. Unit Controls:
 - a. Unit shall be complete with self-contained low voltage control circuit.
 - b. Unit shall incorporate an outdoor coil defrost system to prevent excessive frost accumulation during heating cycle and shall be controlled as follows:
 - (1.) Defrost shall be initiated on the basis of time and coil temperature.
 - (2.) A 30/60/90-minute timer shall activate defrost cycle only if coil temperature is low enough to indicate a heavy frost condition.
 - (3.) Defrost cycle shall terminate when defrost thermostat is satisfied or shall have a positive termination time of 10 minutes.

GUIDE SPECIFICATIONS (CONT)

2. Safeties:
 - a. High Pressure Switch
 - b. Loss of Charge Switch

H. Operating Characteristics:

1. Unit shall be capable of starting and running at 125°F (51.7°C) ambient outdoor temperature.
2. Compressor with standard controls shall be capable of operation down to 40°F (4.4°C) ambient outdoor temperature in cooling duty.
3. Compressor shall be capable of operation in heating cycle down to -20°F (-28.9°C) ambient outdoor-air temperature.
4. Unit shall be capable of simultaneous heating duty and defrost cycle operation when using electric heaters indicated in Section L, Special Features.

I. Electrical Requirements:

All unit power wiring shall enter unit cabinet at a single location.

J. Motors:

1. Compressor motors shall be of the refrigerant-cooled type with line break thermal and current overload protection.
2. All fan motors shall have permanently lubricated bearings and inherent automatic-reset thermal overload protection.
3. Outdoor-fan motor shall be totally enclosed.

K. Grille

1. Louvered Grille:

Louvered grille shall be standard on all units.

L. Special Features Available

1. Coil Options:

Shall include factory-installed optional tin-plated indoor coil.
2. Thermostat:

To provide for two-stage heating and one-stage cooling in addition to manual or automatic changeover and indoor fan control.
3. Low-Ambient Package:

Shall consist of a solid-state control and outdoor coil temperature sensor for controlling outdoor fan motor operation, which shall allow unit to operate down to 0°F (-17.8°C) outdoor ambient temperature in cooling.
4. Crankcase Heater:

Shall provide anti-floodback protection for low-load cooling applications.
5. Electric heaters:
 - a. Electric heater shall be available as a field-installed option.
 - b. Heater elements shall be open wire type, adequately supported and insulated with ceramic bushings.
 - c. Electric heater packages must provide single point power connection capability.
6. Compressor Start Kit:

Shall be available to give a boost to the compressor motor at each start-up.
7. Outdoor Thermostat Kit:

Thermostat allows for staging of electric heaters based on outdoor air temperature.