



Compact Fluorescent

**Roman Coach  
Energy Star compliant**

**Outdoor**

Catalog No.	Finish			Lamping	Dimensions (Inches)			
	Brushed Nickel	Antique Bronze	Black		A	B	C	D
P5985	-09WB	-20WB	-31WB	1 GU-24 26w (included)	4-5/8	10	6-1/8	2-3/4

Type	-09WB	-20WB	-31WB
P5985	<input type="checkbox"/>	<input type="checkbox"/>	<input type="checkbox"/>

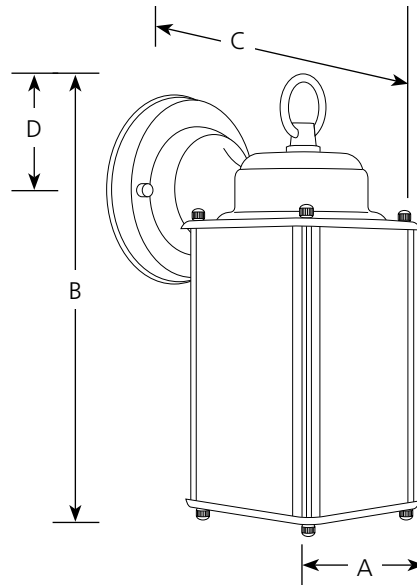

**Specifications:**

General

- Etched glass panels
- Square style
- Aluminum construction
- Plated Brushed Nickel (-09WB) finish
- Painted Antique Bronze (-20WB), Black (-31WB) finishes
- Lamp replacement through bottom opening
- Energy Star Certified
- Companion Close-to-ceiling, Wall lantern, fixtures are available

Mounting

- Wall mount
- Back plate covers a standard 4" hexagonal recessed outlet box
- Mounting strap for outlet box included

Electrical

- GU24 base socket
- Unit will start down to 0 degrees F
- Pre-wired

Labeling

- cCSAus Wet location listed

Progress Lighting  
701 Millennium Blvd.  
Greenville, South Carolina  
29607

www.progresslighting.com

Rev. 07/13