

Class 250 Iron Body Check Valves

Bolted bonnet • horizontal swing • renewable bronze seat and disc*

500 PSI/34.5 bar non-shock cold working pressure to -20°F to 150°F/-29°C to 66°C

Maximum working temperature 450°F/232°C at 250 PSI/17.2 bar

250 PSI/17.2 bar saturated steam to 406°F/208°C

CONFORMS TO MSS SP-71 TYPE 1 • APPROVED BY
THE NEW YORK CITY B.S.A. 143-69-SA AT 350 PSI
NON-SHOCK COLD WATER

MATERIAL LIST

PART	SPECIFICATION
1. Body Bolt	Steel ASTM A307/SAE J429
2. Identification Plate	Aluminum
3. Bonnet	Cast Iron ASTM A126 Class B
4. Body Gasket	Reinforced Graphite
5. Body Nut	Steel ASTM A563
6. Side Plug	Brass ASTM B16 Alloy C36000
7. Hanger Pin	Brass ASTM B16 Alloy C36000
8. Hanger	Brass ASTM B584 Alloy C84400
9. Disc Nut	Brass ASTM B584 Alloy C84400
10. Disc	Brass ASTM B584 Alloy C84400
11. Seat Ring	Brass ASTM B584 Alloy C84400
12. Body	Cast Iron ASTM A126 Class B



F-968-B
Flanged

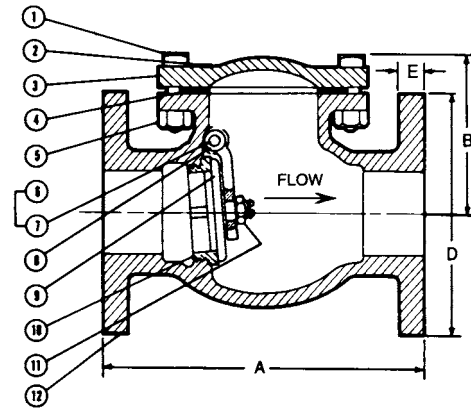

F-968-B
Flg x Flg

DIMENSIONS—WEIGHTS—QUANTITIES

Size	Dimensions								Weight		
	A		B		D		E		Lbs.	Kg.	
In.	mm.	In.	mm.	In.	mm.	In.	mm.	In.	mm.		
2½	65	11.50	292	5.83	149	7.50	191	1.00	25	62	28
3	80	12.50	318	6.31	160	8.25	210	1.13	29	77	35
4	100	14.00	356	7.56	192	10.00	254	1.25	32	129	58
6	150	17.50	445	8.50	216	12.50	318	1.44	37	225	102

*Proper machining facilities required.

Note: On pump discharge, the preferred check valves are:

- inline, spring assisted, center-guided, lift checks
- spring assisted twin (double) disc
- swing design with lever and weight or lever and spring

Install 5 pipe diameters minimum downstream from pump discharge or changes in direction to avoid flow turbulence. Flow straighteners may be required in extreme cases.

NIBCO Iron Body Check Valves may be installed in both horizontal and vertical lines with upward flow or in any intermediate position.

Warning – Do Not Use For Reciprocating Air Compressor Service.